

CONTENTS

525	Staff moral values of Islam are based on a qualitative content analysis technique Negin Sangari, Reza Mirzaian	3544-3552
526	Partitioning of above and belowground biomass and allometry in the two stand age classes of <i>Pinus rigida</i> in South Korea Yeon Ok Seo , Roscinto Ian C. Lumbres , Young Jin Lee	3553-3559
527	Assessment of Antifungal Activity of Chitinase Produced by <i>Bacillus licheniformis</i> EG5 Isolated from Egyptian Soil Abdel-Shakour E. H.	3560-3572
528	Measurements of Natural Radionuclides in Soil samples from Tourbh Governorate, Saudi Arabia Alharbi W.R., Jeddah, Saudi Arabia	3573-3577
529	Analytical Study of the Effect of Dividend Policy and Financing Policy on Market Value-Added in Tehran Stock Exchange Karim RezvaniRaz , Ghasem Rekabdar	3578-3582
530	Association between job stress and job satisfaction among Iranian Gynecologists Morteza Salimi, Minoo Rajai, Hamid Haghighi, Masoud Shareghi, Mojtaba Salimi, Sakineh Fallahi, Seyed Reza Mirsoleymani, Ali Akbar Hesam, Soghra Fallahi, Fatemeh Zare, Sakineh Dadipour	3583-3586
531	The proliferative and apoptotic effects of garlicin on mouse myeloma cell line SP2/0 Hui Wang, Xiangchen Li, Guangbin Wang, Xiaohong He, Weijun Guan, Yuehui Ma	3587-3594
532	Calculation of Generation System Reliability Index: Loss of Load Expectation Mehdi Nikzad, Shoorangiz Shams Shamsabad Farahani, Mohammad Bigdeli Tabar, Hossein Tourang, Behrang Yousefpour	3595-3599
533	Factors affecting adherence level to HAART (Adherence predictors) in Kuala Lumpur, Malaysia Umar Yagoub, Bulgiba A, Peramalah D, Lee C, Chik Z	3600-3603
534	Demographic, Socio-Economic Factors and Physical Activity Affecting the Nutritional Status of Young Children Under Five Years Thanaa. A. Elkholy; Naglaa, H. M. Hassanen and Rasha, M.SC.	3604-3614
535	The Study of Woman's Attitude towards the Presence of the Husband's in the Labor Room during Childbirth Neama Mohamed El-Magrabi and Nadia Abdallah Mohamed	3615-3620
536	The educational approach of allegory in religious texts Dr. Kabiri Sayed Taghi, Kobra Rahimzadeh	3621-3625
537	Introducing an Economic Plan of Optimum Designing in the Joist Floor Slabs Construction Dr. Ahmad Akbarlou	3626-3633

538	The theoretical study and finite elements of effect in the height changes to threshold on the shear strength of steel shear walls Hedayat Veladi, ArashSazghari	3634-3640
539	The pathology of family the dimension of economy with belief approach Asghar Abedzadeh	3641-3647
540	Comparison of cardiac structural, functional indices of male elite swimmers and triathletes with non- athletes Rasoul HashemKandi Asadi, Mir Hamid Salehian, Jafar Barghi Moghaddam, Mehdi Faramoushi	3648-3651
541	Ranking Effective Factors on Knowledge Management system in Bonab Islamic Azad University Behnam Talebi, Roghayyeh Rezayi, Khosro Gholizadeh, Behnam Heidarian, Saeed Zanjani	3652-3658
542	Semantic deviation in Free Verse Hamidreza Farzi, Rostam Amani Astmal, Ali Dehghan	3659-3663
543	The effect of aerobic exercise on IL6, CRP and TNFa concentration in elderly men Ali Besharati, Dr. Seyed Kazem Mousavi Sadati, Mehran Ahadi, Mir Hamid Salehian	3664-3668
544	External or Internal Attention for Vertical Mass Displacement Mir Hamid Salehian, Recep Gursoy, Elhan Şen, Mohsen Shir Mohammad Zadeh	3669-3672
545	Prevalence of House Dust Mites in Two Levels of Dorms (Hotel and Motel) of Jaddah District Western Saudi Arabia Nada Othman Edrees	3673-3683
546	An improved Artificial Neural Network based model for Prediction of Late Onset Heart Failure Nader Salari, Shamarina Shohaimi, Farid Najafi, Meenakshii Nallappan, Isthriyaygy Karishnarajah	3684-3689
547	A Trail of Using Green Tea for Competing Toxicity of Acrylamide on Liver Function Thanaa A. El- Kholi, Nahlaa A. Khalifa, A.K. Alghamidi, and Arwa M. Badereldin	3690-3695

Staff moral values of Islam are based on a qualitative content analysis techniqueNegin Sangari¹, Reza Mirzaian²¹ PhD candidate of Human Resource Management, University of Tehran² Master of Urban Management

Abstract: Contemporary organizations are operating in an environment that is increasingly complex and variable – economic globalization and technological developments in the past two decades were the driving force of these changes, the move towards a knowledge organization and growing demand for employees in the workplace and foster a rich and meaningful work, the pressure is greater, therefore, organizations need to create a work environment where employees feel challenged and meaningful work and it has become a priority for organizations, thus it represents the importance of spirituality in organizations. In this study we have investigated the background of the subject and definitions of spirituality and spirituality is presented in, and for the first time, the components of spiritual values of Islam has been examined and by using qualitative content analysis, all the verses of the Holy Quran, letters and sermons contained in the book Nahjolbalagheh, have been investigated and After coding concepts, and extract categories and main categories three propositions had been extracted as a result of content analysis, it contains spiritual values of employees in connection with God, spiritual values of employees in connection with others, spiritual values of employees in connection with self and spiritual values of organizations in the interaction with employees and an interactive model of the bidirectional relationship between these variables was presented.

[Negin Sangari, Reza Mirzaian. **Staff moral values of Islam are based on a qualitative content analysis technique.** *Life Sci J* 2012;9(4):3544-3552] (ISSN:1097-8135). <http://www.lifesciencesite.com>. 525

Keywords: Spirituality, spiritual values of employees, spiritual values of organization, interaction model

Statement of the problem and the need for research

Today, many people feel dissatisfied and insecurity with their job (Marques, et.al, 2005) Morris believes job satisfaction, confidence and work ethic is rare in most workplaces. Many organization proceedings to change and improve in the past two decades, such as downsizing, re-engineering and suspension have caused the employees demoralized and spiritual confusion. In fact, these proceedings based on the mechanistic paradigm of modern rational have been unable to meet the demands of the employees, employees in their jobs, expect more than economic benefits.

Some researchers believe that the new paradigm to meet the challenges of managing is "Spirituality", They believed that satisfaction higher needs of employees can be traced to the model of spirituality (Kennedy, 2002) because spirituality of work causes creativity, innovation, integrity, trust and commitment in working with a growing sense of personal development of employees to join and self-actualization, and updated its full functionality and capabilities (Morris, 1997).

With the increasing complexities and irregularities that result in a recognized global scale, current institutions and processes must be studied deeply. In this regard, there is no doubt that must perform values in the workplace to protect the moral atmosphere of competitiveness and growth, should

also check that what are the examples of true spirituality and what kind of organizations have been able to run some of spiritual principles and how, the aspect of spirituality in the workplace is that less attention has been paid to it, but it is essential to further understanding of spirituality (Gibbons, 2002).

In this study, the main problem is that because of the importance of spirituality in today's organizations, employee's indices spiritual values of Islam review and identify, because the research so far has not done in this case.

The main research question

What is the components and indicators of spiritual values of employees in the perspective of Islam?

Describing and explaining the issue

The rapid growth of spirituality in the workplace and its application to the leaders, human resource managers, employees and agents of change, is very important. When different aspects of spirituality in the workplace are used Prosperity and individual creativity, organizational coordination, increase long-term commercial success.

With the spiritual working the nature of work will change, now the work has become a tool for personal development of employees. People are searching for meaning in their work that goes beyond mere economic transactions between independent individuals; they are searching for a way to connect their work life with their spiritual life, to work

together and to join the vision and goal that is beyond money. (Ryan & Konz, 1999)

Mirvis (1997) believe the importance of spirituality in organizations that tend to be associated in people's lives because people are spending most of their time at work and their colleagues are their closest friends, as a result they take their social identity from their workplace and what happens to them in the work is very important for their physical health, mental health, prosperity and happiness (Cartwright and Cooper, 1997)

Definition of Spirituality

According to a definition "spiritual is life force and motivation, energy that inspire people towards a certain appeal, or the goal is to transcend individuality" (Mc Knight, 1984) "spirituality as energy, meaning, purpose and awareness in life" (Cavanagh,1999). Meyer defines spirituality as "spirituality is a constant search for meaning and

purpose in life, deep understanding of the value of life, the universe expanded, natural forces, and personal belief systems" (Myers, 1990).

But in a relatively comprehensive and precise definition; spirituality is "an attempt to develop sensitivity to themselves, others, and inhuman creatures (superior force) God, or searched for a man to get what is needed, and Search save considered to achieve full humanity" (Hinnells, 1995). It seems that the definition of both theoretical and practical terms is important. On the one hand, refers to the aspects of human communication, it is inevitable at least in one dimension, on the other hand, efforts and sensitivity training for all humanity offers.

Definition of spirituality at work

The definition of "Spirit at Work" defines spirituality as a very different and difficult, some definitions of the term are listed in Table 1.

Table 1. The definition of "Spirit at Work" defines spirituality as a very different and difficult, some definitions of the term

Row	Defining spirituality involved	Provider	References	Key elements of the definition
1	The concept involves a sense of integrity (wholeness), cohesion (connectedness) work and deep appreciation of the work.	Gibbons	Gibbons, 1999	A deep sense of interdependence of all things / work with meaning
2	In order to establish the relationship between the individual and the way his colleagues and others who have contributed.	Mitroff and Denton	Mitroff and Denton, 1999	Targeted work / communicate effectively with colleagues / alignment between personal values and organizational values
3	Subsequent identification of an individual to understand and work life that is growing within and through social work education is a meaningful life.	Ashmos and Duchon	Ashmos and Duchon (2000)	Communicate effectively with their own / meaningful work/ sensitivity of others
4	Journey to the integration of spirituality for individuals and organizations for excellence and integrity in the workplace provides	Gibbons	Gibbons, 2002	Combining working life and spiritual life / orientation / perfection or non / sense of oneness with everything
5	Inspiring force for continuing to find meaning and purpose in life work, deep and profound understanding of the value of work, life, vast universe of natural species and personal belief system.	Myers	Myers, 1990	Existential dimensions include human / spiritual dimension is part of the spiritual dimensions.
6	Specific circumstances of the individual by the physical dimensions, emotional (Affective), Cognitive, interpersonal, spiritual, Mystical, describing closed. The physical dimensions; feel desirable physical expression of motivation and positive energy. Emotional dimension; is associated with a profound sense of joy. Cognitive dimension, having a sense of self-approval and certification of conformity with his personal values and beliefs, having to do with the means employed and the aim of the observer is transcendental. Interpersonal dimension includes feelings connect with others and share their goals. Spiritual dimension; feelings connect us to something beyond itself, such as a higher power, the universe and human nature. After work; feel perfection and excellence, life is described.	Kinjerski and Skrypnek	Kinjerski and Skrypnek (2004)	Existential dimensions include human / spiritual dimension is part of the spiritual dimensions.
7	Include health, happiness, wisdom, Success and intrinsic satisfaction (Fulfillment).	Dennis, Schmiat and Travis	Dennis, Schmiat and Travis (2004)	Growth and development, spirituality, hope, peace, joy, inner satisfaction.

As was mentioned, the definition of spirituality at work is different; everyone has been defined based on their perspective. Achieve an acceptable definition of the majority, if not impossible, at least very difficult, to appear. But given a fairly comprehensive definition that covers some aspects of the above definitions, it can be helpful. It is used to help define spirituality and spiritual work according to certain features and content types is defined as follows:

"Spirituality at work, efforts to develop sensitivity to the Super Personal, Inter Personal, Intra Personal and Exo Personal relationship outside of work life in order to achieve excellence in human development."

As well as it was before, the above definition encompasses all aspects of human existence to a recent WHO Mental Health - Physiological Human is a means of biological, psychological, social and spiritual. The spirituality of the inner (spiritual and emotional) and external (social and biological) is.

Table 2 Proposed frame work for organizing both organizational and individual spirituality in working with internal and external dimensions provided.

Table 2 proposed framework for the organizing the spirituality at work (Gibbons, 2002)

Levels of	Internal	external
Individual	<ul style="list-style-type: none"> - Reflection and private prayer - A spiritual attitude to work and colleagues - Deep beliefs about the nature of God, the world, humanity, order / disorder 	<ul style="list-style-type: none"> - Observable behaviors - Symbols and words of spiritual - Leadership based on spiritual principles - Career development based on moral principles - Empirical research on spirituality (motivation and, effectiveness at work)
Organizational	<ul style="list-style-type: none"> - A set of principles and values (such as organizing principles provided by Mytrof and Denton) - moral attitude - History and mission of organization - Programs about values - Culture, stories, legends 	<ul style="list-style-type: none"> - Structural properties (such as hierarchy, reward systems) - Spiritual goals (multiple stakeholders, the objectives immaterial) - Spiritual tools (participation, lack of staff layoffs) - Adopt policies to implement the spiritual principles of the organization - Strengthening personal spirituality

This shows that the framework for a better understanding of spirituality in what areas of research should be done. This category will help better empirical studies done on various forms of spirituality, because spirituality itself is a huge global phenomenon (Gibbons, 2002).

The outer phenomena observed in experimental studies and evaluation methods. However, inter-organizational phenomena requires approaches and phenomenological approaches, deductive, or Narrative, according to the study of spiritual values which are related to the internal organization, Qualitative content analysis techniques have been applied.

About the analysis of spirituality in the levels of organization, the levels that have been provided by Milliman and colleagues is also important because links to three levels of individual, team and organizational (Milliman and etal, 2003)

Figure (1) spirituality at work in three levels of individual, group and organizational

Individual level

- Meaningful work
- Enjoy working
- Taking Power and Energy from working

Group level

- Sense of integrity
- Solidarity with colleagues
- Staff supports each other

Organizational level

- Consistency and alignment with organizational values
- Feel connected and correlated with organizational goals
- identify the organization's mission and value

Spiritual values in the perspective of Islam

It seems that, in view of Islam, in addition to social factors and traditions vary there are some fundamental principles and moral values that have inherent source, The origin of these values can be culture and civilization of society, such as religion, science, ethics, traditions, spiritual practices, and history. It can be said that the value system of Islam has been extracted from spirit of Quranic messages and guidance from religious authorities in achieving human perfection and closeness to God.

The value of voluntary action depends on the impact of these actions to achieve true perfection of man (Ali Ahmadi and Ali Ahmadi, 2004).

Background of research

This section refers to some researches that have been done about the spirituality.

Research	Researchers
Spirituality and Psychological Science	(Zinnbauer, Paragament & scott, 1999. Hamilton & jackeson, 1998; Slife. Hope & Nebecke. 1999)
Spirituality and Psychotherapy	(Boadella, 1998; Elkin, 1995, 1999; Karasu, 1999; Mack, 1994; Nino, 1997)
Spirituality and drug addiction	(Bristow.Braitman, 1995; Goldfarb & Galanter, 1996; Jarusiewicz, 1999; Johan. 1993' Miller,1998)

Cessation	
Spirituality and Family Therapy	Prest & Keller, 1991
Spirituality and Stress Management	Quick, Nelson & Hurrell, 1998
Spirituality in Clinical Nursing	(Merarigria, 1999)
Spirituality and Counseling	(Garrett & Wilbar, 1999; Benjamin & Loby, 1996; Parker, Horton & Shelton, 1997; Westgate, 1996)
Spirituality and Social Work Education	(Okundaye & Gray, 1999)
Spirituality and occupational therapy	(Howard & Howard, 1997)
Spirituality and adult education	(Zinn, 1997)
Spirituality and Social and Political Sciences	(Roof, 1998)
Spirituality and Development Program	(Lannone & Obernoluf, 1999)
Spirituality and Sports	(Dillion & Tarit, 2000)

- The effect of spirituality of employees on their job satisfaction, Seyedjavadin, Naserzadeh (2005).
 - Theory of effective leadership of Imam Ali (AS), Danaei fard, Moemeni,(2008).
 - Students build a spiritual experience scale, Ghoobaribonab and others (2005).
 - Models of spirituality and its role in improving organizational citizenship behavior, Farhangi, Fattahi, Vasegh (2006).
 - The theory of spiritual needs in Islam and its correspondence with the Maslow hierarchy of needs, Shojaei (2007).
 - Psychometric characteristics of questionnaires and spiritual attitudes in university students, Sharifi and others, (2008).
 - Spiritually oriented Qur'an Roodgar (2009).
 - The role of human resources empowerment in spiritual organizations, Rezaei and Solomon (1388).
 - Mediating role of spirituality in the relationship between organizational justice aspects and outcomes of spirituality, Yazdani and others (2010).
- As is clear from the results of the background check, most studies examined the relationship between spirituality variable and another variable and there is no review about the indicators of spiritual values of employees especially from the perspective of Islam.

Method of research

In this study, through the technique of content analysis those verses and phrases about spiritual values that are mentioned in the holy Quran and Nahjolbalagheh have been studied and summarized.

Content Analysis

To check the contents of text messages, content analysis method can be used. In this method, explicit content and message is described systematic and quantitative (Bazargan and Sarmad, 1385) Content analysis refers to any type of technical analysis derive in a systematic and objective characteristics are used in a text.

This study reviewed and summarized in the following verses of holy Quran and Nahjolbalagheh book, the main concepts related to spiritual values have been appeared and then through open coding, primary categories were extracted from the concepts.

Then, through axial coding, the main categories were extracted of basic categories and finally through selective coding, the main propositions were obtained as results of the qualitative content analysis.

It contains spiritual values of employees in connection with God, spiritual values of employees in connection with others, spiritual values of employees in connection with self.

But another factor was derived from the content analysis results, spiritual values of organizations in interaction with employees, so that we can argue that Islam has not only given rise to the spiritual values of the people, but to accept spiritual values by employers and organizations have a strong emphasis on interaction with employees and it is rational that there is an interactive and reciprocal relationship between the variables.

Open coding of concepts related to God

Concepts	Category
Praying, fasting, Vigilance , reciting Qur'an, adoring, Jihad in Allah's way	Worship
Faith in God and the Prophet and the Qur'an, obedience, fear, piety, worship God, following God	Virtue
Thanksgiving, Reliance To God, independence, remember God, hope in God's mercy	Reliance
Ask forgiveness, fear of the hereafter and the punishment of God, believe in heaven and hell, remember death	Failure to insist on guilt
God's satisfaction	To obtain God's satisfaction
Regular praying, always remember God	Continuous relationship with God

Purity in faith, defend the faith, keep the tradition of the Prophet	Sincerity
Thanksgiving	Thanksgiving
To fulfill that promise with God	To fulfill that promise with God

Axial coding

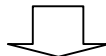

Sub-categories	The main category
worship / Sincerity / Thanksgiving / continuous relationship with God	Humility and obedience to the God
Virtue / not insist on sin / God's satisfaction	To obtain God's satisfaction
Reliance	Reliance
To fulfill that promise with God	To fulfill that promise with God

Selective coding

proposition: spiritual values in connection with God

Open coding of concepts related to others

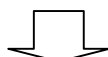

Concepts	Category
Overtaking in goodness, charity, charity Without expecting	Goodness
To fulfill that promise, Trusteeship, Secrecy	To fulfill that promise
Peace, good speech, good morals, eliminate anger, politeness, refrain from arrogance and pride	Geniality
Forgiveness, patience, humility	Magnanimity
Alliance, assist and protect the believers	assist and protect the believers
Invite good and avoid bad, giving advice to others	guiding others
judge with justice, Rule according to the holy Quran, the accuracy of measurement, respect the rights of others, justice in the treasury division	Social Justice
Veracity, constant speech and belief, Being identical in appearance and inner	Honesty
Moderation in behavior, moderation in charity	Moderation
Avoidance of Bribery and points, Just do the responsibilities, loyalty	Rectitude

Selective coding

proposition: spiritual values in connection with others

Open coding of concepts related to self



Concepts	Category
Thinking, researching	Contemplation
Diligence, solvent wage	Diligence
Interest of science operate with insight knowledge, wisdom, foresight, seize good opportunities	Wisdom
Not being dependent on wealth and offspring	Indifference to the world
Adornment appearance, remove clothing	Adornment
patience through obedience, patience against sin, patience for Passion	Patience
Modesty, self-blame, fear of sins, Struggle with self, leave all the ugliness earlier of all	Self-purification
Not wanting excesses	Contentment
Order	Order

Axial coding

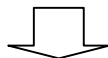

Sub categories	original concept
Contemplation/wisdom	Intelligence
Diligence / Contentment / Self-purification indifference to the world	Self-purification
Order / Appearance Adornment	Adornment
Patience	Patience

Selective coding

Proposition: spiritual values in connection with self

Open coding of concepts related to organization

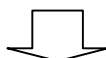

Concepts	category
Training subordinates for guidance and wisdom, self-educated leader before others	education and self education

Good behavior with subordinates	Good behavior with subordinates
Care and Inspection work of subordinates	Monitoring
Praise subordinates and fulfilling their dreams, recalling his valuable work	recognition and appreciation
Careful evaluation efforts of subordinates, Monitoring	Evaluation
Consult with subordinates	Consult
Reward the righteous and punish the wicked	Reward

Axial coding

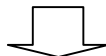

Sub categories	original concept
Monitoring / assessment	evaluation
Good behavior with subordinates	Good behavior
Education, self training	Education & self training
Consultation	Consultation
Reward	reward

Selective coding

Proposition: **spiritual values of organization in interaction with employees**



The following components and parameters of the spiritual values were identified in the perspective of Islam.

Indicators	proposition
To fulfill that promise with God, Humility and obedience to the God, Reliance, To obtain God's satisfaction	spiritual values of employees in connection with God
Intelligence, Self-purification, Adornment, Patience	spiritual values of employees in connection with self
Goodness, To fulfill that promise, honesty, Rectitude, moderation, Magnanimity, geniality, assist and protect the believers, guiding others, Social Justice	spiritual values of employees in connection with others
Evaluation, good behavior, Education & self training, Consultation, reward	Spiritual values of organization in interaction with employees

Conclusion

The organizations believe that human resources are the main source of value creation in an organization and a competitive advantage, effective communication with the superior force (God), with self, with others and with all environmental phenomena causes employees have meaningful work, their work to be targeted, All their talents to be flourished, they Can find a sense of unity and continuity with anything and believe that everything is effective in perfect job and communicate with it.

These outcomes are in response to the four basic needs of man, biological, psychological, social and spiritual that are effective in job growth and will bring joy, hope and peace and the ultimate objective is inner satisfaction and as a result is job satisfaction.

Therefore, considering the importance of the issue and note that the indices of spirituality values of employee, especially from the perspective of Islam, had not been examined, in this study, based on the holy Quran and Nahjbalagheh, this issue was investigated.

AS a result of the qualitative content analysis of mentioned texts, it was determined that in the religion of Islam, Not only the obligation of the spiritual values is emphasized for all people, but it is emphasized that employers also need to accept the spiritual values in interaction with their employees. And it can be concluded that in Islam, before that organizations expect employees to accept spiritual values, must provide the necessary context for the institutionalization of spiritual values in their employees by accepting spiritual values in interactions with them.

Therefore it could be imagine that there is a two-way interactive relationship between variables of the spiritual values of employees and variables of the spiritual values of organization.

Also, it can reasonably be argued that there is a bilateral relationship between the components of the spiritual values of employees, because when a man in connection with God is adhere to spiritual values , in connection with himself and others will consider the spiritual values and thus more in connection with God is committed to spiritual values, so there will be this form of interaction between components of spiritual values of employees.

The interactive relationships among variables are shown in the model below.

For further research in the future, the model can be tested by survey in organizations.

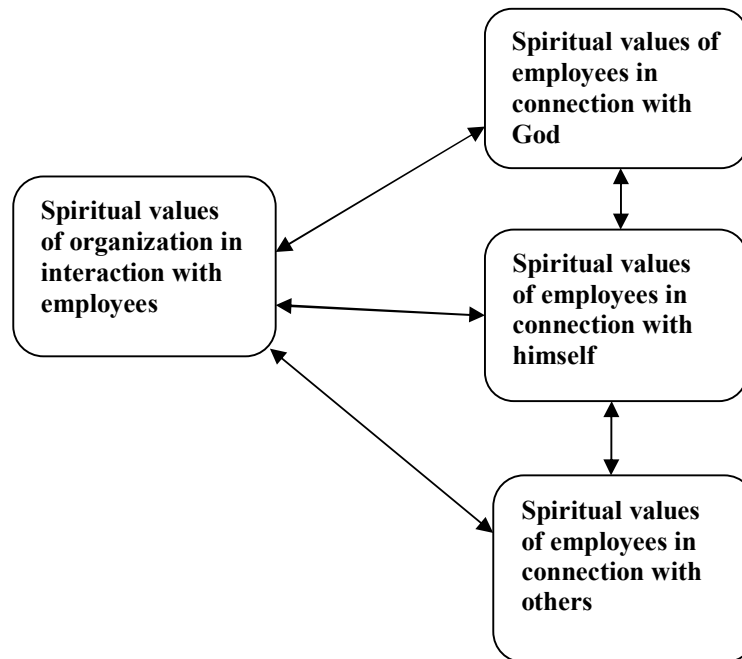

Resources

- The Holy Quran -Nahjol balagheh (2000), translated by Faiz al-Islam. Ali Naqi, Tehran: Feghh .
- Adams, a. Sclerosis. (2003), "Meaning of Life", translated by Z. Golpayegani, magazine reviews and comments, Qom: S 31-32, autumn and winter campaign office Seminary.
- Ali Ahmadi, Ali-Reza Ali-Ahmadi, H. (2004), Principles of Islamic Management, Tehran knowledge production.
- Amirshahi, Mir Ahmad (1997), "An empirical study of management systems and decision-making styles of Iranian managers" Ph.D. dissertation, University of Kourtin, America.
- Ashmos, D. P. & D. Duchon (2000), "Spirituality at Work: Definitions, Measures, Assumption, and Validity Clamims", Paper Presetes at the Academy of Management, Toronto.
- Askari, Soleimani Amiri (2003), "God and the Meaning of Life", Journal of Review and Comment, Qom eighth year, No. 3 and 4, fall and winter.
- Atslender, Peter (1996), Experimental methods in social research, translation Kazem zadeh B., Second Edition, Mashhad: Astan Quds Razavi.
- Bavman, Z. (1998), "Religion, Modernity, and Postmodernity", Blackwell, Oxford.
- Beazley, Debra Ann (2002), "Spirituality Orientation of a Leader and Percieved Servant leader Behavior: a Correlational Study", PhD, Walden University.
- Benner, D. G. (1989). Toward a Psychology of Spirituality: Implivations for Persnality and Psychotherapy, Journal of Psychology and Christionty, 5, pp.19-30.
- Brief, Ramong, A. A. P. (1979), Task Desing and Employee Montivation, Glenview Illi Scott, Foresman.
- Boje, D. (2000), Another View: Approaches to the Study of Spiritual Capitalism, in Biberman, J. & Whitty, M. (Eds.), Work Spirit, the University of Scranton, Pa, PP.xxv-xxii.
- Bradley Jaqui & K. Kauanui Sandra (2003), "Comparing Spirituality on three Southern California College Campuses", Journal of Organizational Change Management, vol. 16, no.4, pp. 48-462.
- Brandt, Ellen (1996), "Corporate Pioneers Explore Spirituality: Pease, Developing Spirituality Within the Company", Journal of HR Magazine, April, vol.41.
- Bridges L. Y., Moore Ka (2002), Religion and Spirituality in Childhood and Adolescence. Washington, DC: Child Trends.
- Bovee, Courtland L. & John V. Thill & Marian Burk & Dowel, P. George (1999), International Management, Ed. McGraw Hill Book Co.
- Burack, E. (1999), Spirituality in the work place, Journal of Organizational Change Management, Vol.12, No.4, pp.280-91.
- Butts, Dan (1999), "Spirituality at Work: an Overview", Journal of Organizational Change Management, 12,1, pp.328-331.
- Brief, Romany, A. A. P. (1979), Task Desing and Employee Motivation Glenview Illi Scott, Foresman.
- Cacioppe, Ran (2002), "Creating Spirit at Work: re-Visioning Otganization Development and Leadership", Leadership and Organizational Development Journal?, vol.21, no.2.
- Cacanagh, G. (1999), "Spirituality for Managers: Vontext and Critique", Journal of Organization Change Managmental, vol.12, no.3.
- Cross, The Oxford Dictionary of The Christial Church (1957) London: Oxford University Press.
- Craigie, Frederic, Jr. C. (1999), Weaving Spirituality into Organizational Life, Health Progress, 19, 2, pp.25-28.
- Conley, J. & F. Wanger-Marsh (1998), "The Integration of Business Ethic and Spirituality in the Workplace", Insights on Leadership: Service. Stewardship. Spirit and Servant Leadership, Spears, L. (Ed) New York: Wiley & Sons.
- Conger, J. A. (1994), Spirit at Work: Discovering the Spirituality in Leadership, Jossey-Bass, San Francisco, CA.
- Daft, Richard L. (1997), Organization Theory and Design, Sixth, Ed. South- Western College.
- Danaei fard, Moemeni, (2008), Theory of effective leadership of Imam Ali (AS), Journal of the Islamic Revolution.
- Deborah, Block, & Lee J. Richamond (Eds.) (1997), "Connection between Spirit and Work" in Career Development, Davies Black Publishing.
- Deci Edward L., M. Ryan Richard (1985), "Intrains Motivation and self-Determination", in Human Behavior, New York Plenum.
- Dehkhoda, A.A (1945), Dictionary, Tehran: Tehran University.
- Dehler, Gordon E. & M. Ann Welsh (1997), "Spirituality and Organizational Transformation", Journal of Managerial Psychology, 9, 6, pp.17-26.
- Dennis, Heato P., J. Schmiat-Wilk & F. Travis (2004), "Constructs, Methods, and Measures for Researchnig Spirituality in

- Organizational Change Management, Vol, 17, no.1, pp.62-82.
- Drucker, Peter F. (1992), *Managing for the Future: The 1990s and Beyond*, New York: Truman Tally Books/Dutton.
- Emmons, R. & C. Crumpler (1999), "Religion and Spirituality? The Roles of Sanctification and the Concept of God", *The International Journal for the Psychology of Religion*, 9(1), pp.17-24.
- Farhangi, Fattahi, Vasegh (2006), *Models of spirituality and its role in improving organizational citizenship behavior*.
- Fields, R., R. Taylor Weyler & R. Ingrasci (1994), *Mindfulness and Meaningful Work*, Parallax Press: Berkeley.
- Freshman, Brenda (1999), "An Exploratory Analysis of Definitions and Applications of Spirituality in the Workplace", *Journal of Organizational Change Management*, 12, 4, pp.318-327.
- Fontana, David (2003), *Psychology, Religion and Spirituality*, Abps Blachwell.
- Fontana (2005), *Psychology, Religion and Spirituality*, translated Sawari, Qom religious publishing.
- Forum, Eric (1982), *Man for himself (Research in moral psychology)*, translated by A. Tabrizi, Tehran: Behjat.(1998), *Healthy People*, translated by A. Tabrizi, Tehran, Second Edition, published by Behjat.
- Frankl, Victor (1995), *a man in search of meaning*, translation, Maarefi, Tehran: Tehran University.
- Ghazi Tabatabai (2003), *the specific research techniques (social sciences)*, Tehran Payame Noor University.
- Gerald F. Cavanah,(1999) ,*Spirituality for Managers: Context and Critique* ,*Journal of Organizational Change Management*, Vol.12 ,No.3 ,pp.186-199, MCB university.
- Ghobaribonab,(2005),*Students build a spiritual experience scale*.
- Gibbons, P. (2001), *Spirituality at Work: A Pre-Theoretical Overview*, MSC, Thesis-Birnbeck College, University of London: Aug.
- Griffin, D. R. (Ed.) (1998), *Spirituality and Society: Postmodern Spirituality, Political Economy, and Art*, Albany: State University of Management Executive, 10, pp.8-17.
- Gozdz, Kazimierz (ed.) (1995), *Community Building: Renewing Spirit & Learning in Business*, San Francisco: New Leaders Press.
- Gtyngnam (2003), "Meaning of Life", translated by Seyed Mahmoud Mousavi, magazine reviews and comments, Qom No. 31-32, fall and winter, campaign office Seminary.
- Hall, D. T. (1996), "Protean Careers of The 21th Century", *The Academy of Management Executive*, 19, pp.8-17.
- Harman, Roger E. & Gioia Joice L. (1998), *Making Work Meaningful: Secret of The Future-Focused Corporation*, *Futurist*, 32, 9, pp.35-38.
- Hansen, L. S. (2001), "Integrating Work, Family, and Community Through Holistic Life Planning", *Journal of Career Development Quarterly*, 49, pp.261-277.
- Heels, Paul & Linda Wood Head (2005), *The Spiritual Revolution: Why Religion is Giving Way to Spirituality*, Blackwell.
- Herman, Roger E. & Gioia Joice L. (1998), *Making Work Meaningful: Secret of the future-Focused Corporation*, the *Futurist*, 32, 9, pp.35-38.
- Herzberg, F. Mausner, B & B. Snyderman (1959), *The Motivation to Work*, Wiley New York,
- Hicks, Douglas A. (2003), *Religion and the Workplace: Pluralism, Spirituality, Leadership*, Cambridge University Press.
- Hill Pererc, & W. Hood Palph (2001), *Measures of Riligiousity*.
- Hinnells R., John (1995), *A New Dictionary of Religions* Blackwell.
- Holman, peggy (2000), "Culture Change", *Journal Executive Excellence*, 17, 7.
- James, W. (1961), "The Varieties of Religious Experience", Penguin: NY.
- Kazemi, KH: *Management with emphasis on spirituality*, Tadbir Magazine No. 149, pp. 79-80, 2003.
- Kennedy, Michael Henry (2002), "Spirituality" in the Workplace: An Empirical Study of this Phenomenon, DBA, Nove Southeastern University.
- Khaki, G. (2000), *research methods*, Tehran: State Scientific Research Center.
- Khoramshahi, Baha (1981), *logical positivism*, Tehran: Center for Scientific and Cultural Publishers.
- Kinjerski, Val M. & J. Skrypnec Berna (2004), "Defining Spirit at Work: Finding Common Ground", *Journal of Organizational Change Management*, vol. 14, no.1, pp.26-42.
- King Sandra & M. Nicol Dave (1999), "Organizational Enhancement Through Recognition of Individual Spirituality, Reflections of Jaques and Jung", *Journal of Organizational Change Management*, vol. 12, no.3.
- Konz, Gregory N. P. & Francis X. Ryan (1999), "Maintaining an Organizational Spirituality: No Easy Task", *Journal of Organizational Change Management*, 12,3, pp.200-210.
- Kouzes, J. & B. Posner (1995), *The Leadership Challenge: How to keep Getting Extraordinary Thing Done in Organizations*, Jossey-Bass, San Francisco, CA.
- Krishnakumar, S. & C. p. Neck (2002), "The What, and How, of Spirituality in the Workplace", *journal of Managerial Psychology*, vol.17. no.3,pp.153-164.
- Lund Dean, Diane Kitherine (2002), "Religion, Spirituality and Work: Transcendence in the Organization", PhD., Saint Louis University.
- Marques, J.F,(2006) *The spiritual worker*,*Journal Of Management Development*,Vol.25,No,9 ,pp884-95
- McCormick, Donald W. (1994), "Spirituality and Management", *journal of Managerial Psychology*, vol.9, no.6, pp.5-8.
- McDonald, Marci (1999), *Spirituality at Workplace*, (U. S. News, and World Report), May 3.
- McKnight, R. (1984), *Spirituality in the Workplace*, In Adams, J. D. (ed), *Transforming Work*, Milles River Press, Alexandria, VA.
- Miller, W. (1998), *How do we Put our Spiritual Values to Works*, Berrett-Koehler, San Francisco: CA.
- Milliman, J. & Andrew J. Czaplewski & Ferguson Jeffery (2003), "Workplace Spirituality and Employee Work Attitudes", *Journal of Organizational Change Management*, vol. 16, no.4, pp.426-447.
- Mitroff, I. A., & E. A. Denton (1999), "A Study of Spirituality in the Workplace", *Hournal Sloan Management Review*, Summers. (1999), *A Spirituality Audit of Corporate America: A Hard Look at Spirituality, Religion, and Value in the Workplace*, Jossey-Bass, Son Francisco: CA. (1999a), "A Spiritual Audit of Corporate America: A Hard Look at Spirituality, Religion, and Value in the Workplace", *Journal of Sloan Management Review*, 40, pp.63-84.
- Moghimi, SM (2001), *organization and management, research approach*, Tehran: Termeh.
- Moghimi, SM, Rahbar. Eslami, H., (2007), *organizational spirituality and its effect on employee creativity*, *Journal of Ethics in Science and Technology*, Second Year, No. 3 and 4.
- Mohamed, A. A., A. M. Hassan & J. M. Wisnieski (2001). *Speretualety in the Workplace: A Literature review*. *Global Competitiveness*, 9, pp.644-652.
- Myers, J. E. (1990), *Wellnes Throughout the Lifespan*, Guidepost, May.
- Neal, J. A. (1997), "Spirituality in Management Education: a Guide to Resources", *Journal of Management Education*, vol.21, no.1, February, pp. 39-139.
- B. M. B. Lichtenstein & D. Banner (1999), "Spiritual Prespectives on Individual, Organizational and Societal Transformation", *Journal of Organization Change Management*, vol. 12, no.3, pp.175-185.
- J. Bennedt (2000), "Examining Multi-Level or Holistic Spirituality Phenomena in the Workplace", *Management, Spirituality, Religion Newsletter*, Academy of Management, Winter, pp.1-12.
- Neck, C. & J. Milliman (1994), "Thought self-Leathership: Finding Spiritual Fulfillment in Organizational Life", *Journal of*

- Managerial Psychology, vol.9, no.6, pp.9-16.
- O'Connel, B. (1999), *The Spiritual Journey of the Corporate Warrior*, Presented at Massey University, Albany Campus, Auckland, www.O'conner.
- Oliveri Arnaldo (2001), "The Place of Spirituality in Organizational Theory", *Journal of Business Ethics and Organization Studies*, vol.9, no. Email: aliveira@Hawaii.com.
- O maskaran (2002), *Research methods in management*, translation M. Saebi, Mohammad Shirazi, Tehran: Center for Public Management.
- Oun, H. Follow. (2001), *views about God*, translated by Bakhshandeh.H, Qom illumination.
- Oupnehama, a.a.n. (1990), *a questionnaire designed to measure attitudes*, translated by M. Krymnya, Mashhad: Astan Quds Razavi.
- Palmer, J. (2001), *Spirituality at Work*, *Business Record*, 17, pp.15-22.
- Paragament, K. (1999), "The Psychology of Religion and Spirituality? Yes and No?", *The International Journal for the Psychology of Religion*. Vol.9, no.1, pp.3-16.
- Popper, Karl Raymond (1990), *Logic of Scientific Discovery*, translated by Seyyed Hossein Kamali, Tehran: Scientific and Cultural Publishing Company.
- Rajvanshi Ail K. (2004), *Nature Conservation + Spirituality= Sustainability*, Nariphtan Sancharnet, in.
- Rastgar, Abbas ali,(2010),*Spirituality in organization, A psychological approach*, the university of religions.
- Rezaei and Solomon (1388), *The role of human resources empowerment in spiritual organizations*.
- Richards, P. Scott & Alledn E. Bergin (2005), *A Spiritual Strategy for Counseling and Psychotherapy*. 2th ed., Washington, DC: American Psychological Association.
- Rojas, Ronald Raymond (2001), *Management Theory and Spirituality: A Framework and Validation of the Independent Spirituality Assessment Scale*, DBA, Argosy University/Sarasota.
- Roodgar (2009),*Spiritually oriented Qur'an*.
- Santos. S. (2006), *What is Spiritual Intelligence? How it Benefits a Person?*, p.1,
- Scott, Richard (1994), *organizations as rational systems, natural systems and open systems*, translation and Flora H. Mirzaei Ahranjany Soltani, Tehran: Tehran University Press.
- Seyedjavadin, Naserzadeh (2005), *The effect of spirituality of employees on their job satisfaction*.
- Sharifi, (2008),*Psychometric characteristics of questionnaires and spiritual attitudes in university students*.
- Sherman, Allen, C., & Stephanie Simonton (2001), *Assessment of Religiousness and Spirituality in Health Research*, In, Plant Thomos G. & Allen C. Sherman (eds.) *Faith and Health: Psychological Perspective*. New York and London" The Guilford Press, pp.132-163.
- Shojaei (2007), *The theory of spiritual needs in Islam and its correspondence with the Maslow hierarchy of needs*.
- Sisk. D. (2008), *En Gaging the Spiritual Intelligence of Gifted Students to Build Global Awareness in the Classroom*, *Academic Research library*, 30:24-30.
- Smith (1382), "The Meaning of Life in World Religions", translated by M. Maleki, magazine reviews and comments, Qom: Q 32, autumn and winter campaign office Seminary.
- Stace, v.t. (1987), *Mysticism and Philosophy*, translated by Baha eldin Khoramshahi, Tehran, Third Edition, Soroush. Tishchler, L., J. Biberman & R. McKeage (2002), "Linking Emotional Intelligence, Spirituality and Workplace Performance: Definitions, - Models and Ideas for Research", *Journal of Managerial Psychology*, no.1, 14, no.3, pp.203-218.
- Ursula King (1999), *Spirituality in New Handbook of Living Religions*, pp.667-681, Blackwell. (1999), *Spirituality in New Handbook of Living Religions*, pp.667-681, Blackwell.
- Underhill, E. (1997), *The Spiritual Life*, Hodder and Stoughton, London.
- Vaughan, F. (2003), *What is Spiritual Intelligence?*, *Journal of Humanistic Psychology*, vol.42, no.2, pp.16-33.
- Vaill, P. (1989), *Managing As a Performing Art: New Ideas for a World of Chaotic Change*, Jossey-Bass, San Francisco, CA.
- Wainwright, Geoffrey (1987), *Christian Spirituality*, in M. Elide, ed., *the Encyclopedia of Religion*, New York: Macmillan/London, Collier Macmillan, vol.3, pp.452-460.
- Walsh, Dian C. (1998), "Spirituality and Leadership", *The Hearth of Learning: Spirituality in Education NY: Penguin Putnam Inc.*, pp.2003-216.
- Wanger-March, Fraya & James Conley (1999), "The Fourth Wave: The Spirituality-Bases Firm", *Journal of Organizational Change Management*, 12:4, pp.292-301.
- West, William (2003), *psychoanalyzed and spirituality*, Tehran growth.
- Wilber, K. (1998), *The Marriage of Sense and Soul: Integrating Science and Religious*, Random House: New York.
- Yazdani,(2010), *Mediating role of spirituality in the relationship between organizational justice aspects and outcomes of spirituality*.
- Zamani, Shahriyar (2002), *the story of spirituality in modern times "of Galileo to Freud"*, Tehran: Bureau of Islamic culture.
- Zohar, D., & I. Marshall (2000), *SQ: Spiritual Intelligence: The Ultimate Intelligence*, New York: NY, USA: Bloomsbury.

11/19/2012

Partitioning of above and belowground biomass and allometry in the two stand age classes of *Pinus rigida* in South Korea

Yeon Ok Seo¹, Roscinto Ian C. Lumbres^{1,2}, Young Jin Lee^{1*}

¹Department of Forest Resources, Kongju National University, Yesan, Chungnam 340-802, Korea

²College of Forestry- Benguet State University, La Trinidad, Benguet, 2601, Philippines

leeyj@kongju.ac.kr

Abstract: This study was conducted to determine the influence of age class on aboveground and belowground biomass partitioning and to develop allometric equations for the estimation of *Pinus rigida* biomass in South Korea. To determine the biomass of the stem wood, stem bark, branch and foliage, trees were harvested and roots were excavated, after which the dry weight of each biomass component was determined. Results showed that the mean biomass of *Pinus rigida* for stand 1 (<21 years) was 12.28kg, whereas the mean biomass for stand 2 (21-40 years) was 129.35kg. The proportion of stem wood biomass to total aboveground biomass increased from stand age class 1 (55.8%) to stand age class 2 (69.3%). Although stem biomass percentage tends to increase as stand age increase, it is not recommended to exclude secondary tree component biomass such as foliage, branches and roots, as this will significantly underestimate the total biomass and carbon storage potential of a forest. The mean root to shoot ratio for the two age classes were 0.20 and 0.26, respectively, and a high correlation was also observed between aboveground and belowground biomass tree components and the DBH. The highest R^2 value was observed in the total biomass with 0.99 for both stand age classes. It was also observed that the biomass tree component have different equation parameters and significant difference between the two age classes, and thus, the allometric equations developed should be applied based on the age of the stand.

[Seo YO, Lumbres RIC, Lee YJ. **Partitioning of above and belowground biomass and allometry in the two stand age classes of *Pinus rigida* in South Korea.** *Life Sci J* 2012;9(4):3553-3559] (ISSN:1097-8135). <http://www.lifesciencesite.com>. 526

Keywords: Allometric equation, carbon, *Pinus rigida*, stand age, tree component biomass

1. Introduction

Member countries are required to accurately assess the carbon stocks available in their forests, and figures for such carbon stocks are regularly reported as forest resources status, based on the United Nations Framework Convention on Climate Change (UNFCCC) (Basuki et al. 2009; Kim et al. 2011). Approximately, 80% of all aboveground carbon (C) and 40% of belowground C were reported to be stored in the forest biomass (Dixon et al. 1994). Furthermore, Lim et al. (2003) stated that carbon budgets, especially in forest ecosystems, are very important as they are considered as a major sink for carbon and have the potential to release this carbon in cases of deforestation and degradation. Because of the potential impact of forests to global climate change, carbon stock estimations for forest have become a major research interest (Watson et al. 2000; Lehtonen et al. 2004; Tobin and Nieuwenhuis 2007; Bollandas et al. 2009; Teobaldelli et al. 2009; Li et al. 2010a). In order to determine the amount of carbon stored in a particular forest, biomass must be accurately estimated (Xiao and Ceulemans 2004; Fehrmann et al. 2008; Chung et al. 2009; Hosoda and Iehara 2010).

In 2010, Korea Forest Service (KFS) reported that the Republic of Korea (South Korea)

has a total of 6.370 million ha of forest land, covering approximately 64% of the total land area (KFS 2010). Coniferous forests account for 2.672 million ha or about 42% of the total forest lands, and the third most dominant coniferous species in this country is *Pinus rigida* (Miller), belonging to the family Pinaceae. The species originated from North America (Mirov 1967; Kwon and Lee 2006). The land area covered by *Pinus rigida* in South Korea is approximately 0.41 million ha or 15.2% of the total coniferous forest area (Lee 2010), and hence, there is significant need to accurately estimate the biomass of this species.

In most forest inventories, diameter at breast height (DBH) of trees is measured. In order to use this existent data to estimate biomass, allometric equations must be developed. According to Teobaldelli et al. (2009), forest inventory data can be used to estimate biomass and carbon stocks in this manner. Furthermore, allometric regression equations can serve several other purposes, such as calculation of ecosystem properties like carbon, nutrient and water dynamics (Son et al. 2001). However, Kim et al. (2011) reported that the age of a stand has a great influence on the allometric factors. It was recommended that forest biomass must be calculated using site-specific (age) allometric equations. Studies have previously been conducted to develop

allometric equations for biomass estimation of *Pinus rigida* in Korea (Kim 1999; Seo et al. 2006), however, there is still insufficient information on the effects of stand age on biomass partitioning and allometry. This study was conducted to determine the influence of stand age on aboveground and belowground biomass, and to develop allometric equations for biomass estimation in two stand age classes (< 21-year-old, 21- 40-year-old).

2. Material and Methods

Study sites

Study sites were located in various *Pinus rigida* plantations in South Korea. Coniferous forests dominate the forest land of this country with 2.672 million ha, or about 42% of forest coverage. Mixed forests account for 1.844 million ha or 29%, and broadleaved forests account for 1.66 million ha or 26% of forest coverage, with other types of forests accounting for 0.18 million ha or 3% coverage (KFS 2010). The majority of coniferous forest are dominated by *Pinus densiflora*, covering 1.48 million ha or 54.9% of the total coniferous forest lands. This is followed by *Larix kaempferi* and *Pinus rigida* with 0.46 million ha (17.2%) and 0.41 million ha (15.2%) coverage, respectively (Lee 2010).

South Korea has a temperate climate, with four distinct seasons. In the northern region, the annual mean temperature is 3°-10° Celsius while in the Central region and southern region it is 12°-14° Celsius, and the annual mean precipitation ranges from 600mm to 1600mm (Lee 2010).

Data collection and analysis

A total of 14 plots were established, eight of which were 10m by 10m while six were 20m by 20m. In each plot, one tree which represented the entire DBH range was harvested. Suppressed trees, wolf-trees, and the top-part damaged trees were not harvested. Sampled trees were felled 0.2m from the ground. The average age of the sampled trees in younger stands was 16 years, ranging from 11 to 20 years, whereas the average age observed for the older stands was 33 years, ranging from 21 years to 40 years. The mean DBH of the sampled trees for the younger and older stands were 6cm and 18cm and the mean total height of the sampled trees were 5m and 13m, respectively (Table 1).

Stem discs of 5cm thickness were collected from every 2m section of the stem, where the first and last discs were collected from the first and last 1m of the log. After collecting the discs, the remaining stems, or trunks, were weighed in order to determine the fresh weight. Different data were also collected from the discs, such as the diameter of the inside and outside bark. The oven-dry weight of the

discs were then measured after disc samples were dried at 85° Celsius until constant weights were observed. The dry weight and ratio of the dry weight to fresh weight of discs were then determined.

Table 1. Summary of the observed statistics for *Pinus rigida* stands in South Korea.

Age class	Stand 1 (<21 years)	Stand 2 (21-40 years)
<i>n</i>	6	8
Age(year)	16 (11~20)	33 (21~40)
DBH(cm)	6 (3~12)	18 (11~23)
Height(m)	5 (2~9)	13 (9~17)
Altitude(m)	189 (155~305)	246 (155~450)
Slope(°)	11 (10~15)	14 (10~21)

Note: Mean values are represented with ranges in parenthesis.

The roots, or belowground biomass of the harvested trees were excavated using a fork crane. After removing soils from the roots, the total fresh weight of the belowground biomass was determined on site. Other biomass components, such as the branches and foliage were partitioned. The total fresh weight of branches and foliages in all sampled trees were determined. Furthermore, 350g samples of each biomass component, such as the branches, foliage and roots were then sampled, and were also dried at 85° Celsius constant temperature for about 10~14 days. The dry weight of branches, foliages and roots, as well as ratios of dry to fresh weights were obtained. The ratio of belowground to aboveground (*R*) biomass was then calculated using the standard method of division, as suggested by the Intergovernmental Panel on Climate Change (IPCC) (IPCC 2006). These ratios can be easily applied to estimations of the belowground biomass of forests of the same species, for which only data for aboveground biomass exists.

In order to develop allometric equations, aboveground and belowground biomass (*Y*) were regressed with DBH (*X*) using a log-log (base 10) transformation ($\log Y = a + b \log X$) (Son and Kim 1998; Son et al. 2001; Noh et al. 2010). This model form was used in this study because it was recommended by the Korea Forest Research Institute (KFRI 2006) for Korean tree species, and provides a simple, relevant and standardized measurement. Using coefficients of determination (R^2) and root mean square error (*RMSE*) values, the goodness of fit was calculated. The collected data were statistically analyzed using SAS 9.1 (SAS Institute Inc. 2004). To correct for bias in log-transformed allometric equations, Sprugel correction factors (Sprugel 1983) were used (Son and Kim 1998; Son et al. 2001). To determine if there was a significant difference

between the allometric equations developed for the two stand age classes, analysis of variance (ANOVA) was used. The null hypothesis was tested at a 95% level of confidence. Hence, to reject the null hypothesis for a one-tailed test, the p -value should be lower than 0.05.

3. Results and Discussion

Tree Biomass

The observed mean biomass of the different tree components, including total aboveground and belowground biomass are presented in Table 2. It was observed that the mean biomass of each tree component was higher in the older stand. The mean total biomass of the younger stand was 12.28kg/tree whereas for the older stand, it was 129.35kg/tree. The mean aboveground biomass for the two stand age classes were 10.30kg/tree and 103.70kg/tree, respectively, where the mean belowground biomass were 1.98kg/tree and 25.66kg/tree. As expected, it was observed that in both stand age classes, stems accounted for the greatest proportion of total biomass with 6.78kg/tree and 82.35kg/tree, respectively.

Table 2. Partitioning of the trees component biomass of the two stand age classes of *Pinus rigida* in South Korea.

Tree component	Biomass(kg/tree)	
	Stand 1	Stand 2
Stem	6.78 (\pm 8.44)	82.35 (\pm 54.85)
Stem wood	5.74 (\pm 7.30)	71.90 (\pm 49.06)
Stem bark	1.04 (\pm 1.14)	10.44 (\pm 5.86)
Branch	2.09 (\pm 1.86)	14.29 (\pm 10.92)
Foliage	1.43 (\pm 1.24)	7.04 (\pm 2.91)
Above-ground	10.30 (\pm 11.07)	103.70 (\pm 67.11)
Root	1.98 (\pm 2.03)	25.66 (\pm 14.76)
Total	12.28 (\pm 13.09)	129.35 (\pm 80.72)

Note: Values are mean with standard deviation in parenthesis.

The proportion of canopy biomass, or the sum of the foliage and branch biomass were 34% and 21% for the younger and older age classes, respectively. Based from these results, it is not recommended to exclude secondary tree component biomass such as foliage, branches or roots, as this will significantly underestimate the total biomass and C storage potential of a forest (Peichl and Arain 2007).

The biomass distribution of the different aboveground tree components of stand 1 were 55.8% for stem wood, 20.3% for branches, 13.8% for foliage and 10.1% for stem bark, while the biomass distribution in stand 2 was 69.3%, 13.8%, 10.1% and

6.8% for stem wood, branches, stem bark and foliage, respectively (Figure 1). Results showed that stand age has a significant influence on tree biomass partitioning. The contribution of stem wood to the total aboveground biomass increased from the younger stand to the older stand. However, this was not the case for foliage and branches. It was observed that the contribution of foliage and branch biomass to total aboveground biomass decreased from stand 1 to stand 2. These results are similar to those of previous studies indicating that as stand age increases, the relative proportion of stem wood biomass increases, whereas the relative proportion of foliage and branch biomass decreases (Noh et al. 2010; Peichl and Arain 2007). It was also observed for the older stand that the relative proportion of stem bark biomass was higher than that of foliage biomass. This result is similar to that of Noh et al. (2010) on the partitioning of *Pinus densiflora* in Korea, where stem bark biomass was also higher than foliage biomass, particularly in the 44-year-old and 71-year-old stands of the study. Furthermore, Kim (1999) reported that the biomass distribution pattern of 31-year-old *Pinus rigida* stands was 69% for stem wood, 16% for branch, 11% for stem bark and 4% for foliage.

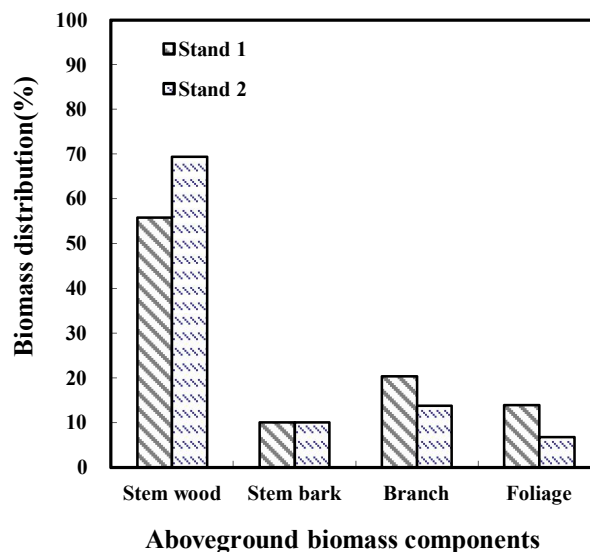

Figure 1. Comparison of the distribution (%) of tree component biomass to the total aboveground biomass between the two stands of *Pinus rigida* in South Korea.

The contribution of root biomass to total biomass for the two age classes increased with age, as 16.1% for stand 1 and 19.8% for stand 2 (Figure 2). Noh et al. (2010) reported that root biomass percentage of *Pinus densiflora* in Korea increased as stand age increased, with 17.6% observed for a 10

year old stand, and 20.8% observed for a 71 year old stand. It was observed that the proportion of branch biomass is higher compared to the proportion of root biomass in younger stands. This result differs compared to the study of Noh et al. (2010) which reported that root biomass was greater than branch biomass. Seo et al. (2006) also reported that *Pinus rigida* stands of less than 21 years have a greater relative proportion of root biomass (18.7%) than branch biomass (13.2%). This may be due to poorer site conditions of the younger stands in this study. According to Noh et al. (2010), site condition can strongly influence the allocation of biomass.



Figure 2. Partitioning of biomass aboveground and belowground in the two stands of *Pinus rigida* in South Korea.

The mean ratio of the belowground and aboveground biomass, or R , of the six trees sampled from younger stands was 0.20 whereas for the eight trees of older stands, it was 0.26. The mean R of all trees was 0.23. Seo et al. (2006) reported that the R of *Pinus rigida* for stands of less than 21 years was 0.18, 0.24 for 21-year-old to 40-year-old stands, and 0.15 for stands older than 40 years. One of the limitations of the present study is that it did not analyze stands older than 40 years. Koch (1989) reported that the average R of the main species in America was 0.17. Furthermore, Cairns et al. (1997) suggested that R values generally ranged from 0.2 to 0.3 while Whittaker and Marks (1975) reported that the average R value is 0.2. In South Korea, the KFRI suggested that the R value for coniferous species is 0.28, and 0.41 for the broadleaf species (KFRI 2008). Most R values suggested by previous literature are comparable with the results of this study. Accurate R

values for a particular species are important because these values allow forest managers to easily estimate belowground biomass where only aboveground biomass data is available. According to Li et al. (2010b), belowground biomass is usually estimated by applying R values to the aboveground biomass or by using allometric equations, because direct field measurement of belowground biomass is very time consuming, laborious and difficult. Furthermore, the IPCC (IPCC 2006) suggested that country-specific R values can be used to estimate belowground biomass for mass calculations. An allometric equation was also developed to determine the linear relationship between the belowground and aboveground biomass and it is shown in Figure 3. The R^2 for this equation was 0.91.

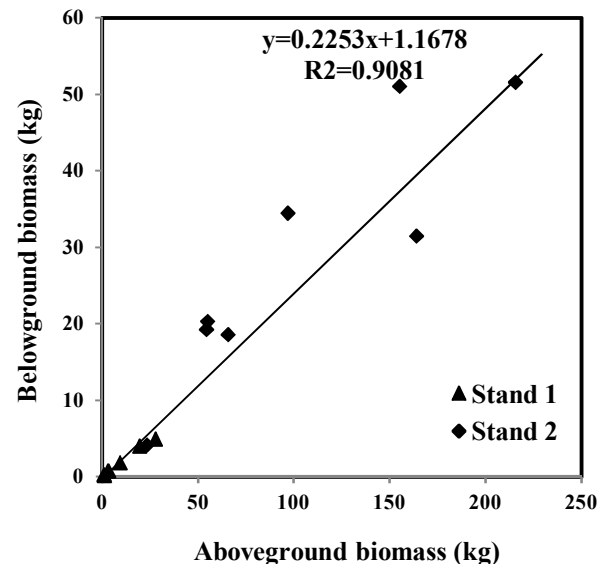

Figure 3. Relationship between aboveground and belowground biomass of *Pinus rigida* in the two stands in South Korea.

Allometric equations

Allometric equations were developed to estimate total biomass and different tree component biomass using DBH values. Results are presented in Table 3. A high correlation was observed from the different aboveground and belowground biomass tree components to DBH. The highest R^2 was observed for aboveground biomass in stand 1 with 0.997 correlation between the calculated and estimated values observed for both stand age classes. The lowest R^2 was observed for foliage estimations, which was 0.862 for stand 1, and 0.734 for stand 2. It was also observed that biomass tree components have different equation parameters in the two age classes.

Table 3. Biomass equations* for the tree component biomass of the two stands of *Pinus rigida* in South Korea.

Tree component	<i>a</i>	<i>b</i>	<i>RMSE</i>	<i>R</i> ²	<i>SEE</i>	<i>CF</i>
Stand 1						
Stem	-3.542	2.642	0.270	0.977	0.135	1.009
Stem wood	-3.888	2.714	0.318	0.970	0.159	1.013
Stem bark	-4.632	0.316	0.139	0.992	0.069	1.002
Branch	-4.368	2.550	0.563	0.900	0.282	1.040
Foliage	-2.832	1.624	0.430	0.862	0.215	1.023
Above-ground	-2.585	2.441	0.093	0.997	0.046	1.001
Root	-4.198	2.427	0.407	0.939	0.204	1.021
Total	-2.391	2.433	0.136	0.993	0.068	1.002
Stand 2						
Stem	-4.822	3.154	0.171	0.959	0.070	1.002
Stem wood	-5.266	3.257	0.187	0.955	0.076	1.003
Stem bark	-5.056	2.541	0.095	0.940	0.039	1.001
Branch	-5.050	2.626	0.314	0.829	0.128	1.008
Foliage	-2.357	1.484	0.235	0.734	0.096	1.005
Above-ground	-3.991	2.952	0.170	0.954	0.069	1.002
Root	-5.986	3.161	0.263	0.909	0.107	1.006
Total	-2.381	2.428	0.129	0.994	0.053	1.001

* Equations follow the form $\log Y = a + b \log X$, where *X* is DBH (cm) and *Y* is biomass(kg), *RMSE* is root mean square error, *R*² is coefficient of determination, *SEE* is the standard error of estimate and *CF* is Sprugel correction factor.

Furthermore, results of ANOVA showed that there was significant difference between the aboveground biomass allometric equation of stand 1 and stand 2 and belowground biomass allometric equation of stand 1 and stand 2, with *p*-values of 0.005 and 0.003, respectively. Similar results were observed for the total biomass estimations through the allometric equations for stand 1 and stand 2, with a *p*-value of 0.005. Thus, it is recommended that the individual allometric equations developed in this study should be applied based on the age of the site. The *RMSE* ranged from 0.093 to 0.563 for stand 1 and 0.095 to 0.314 for stand 2. The standard estimation of error (*SEE*) observed in this study ranged from 0.046 to 0.282 in stand 1, and from 0.039 to 0.128 in stand 2. The highest *CF* was observed for branches (1.04) while the lowest *CF* was observed for the aboveground biomass allometric equation for stand 1 (1.001). For stand 2, the lowest *CF* was determined for stem bark and total biomass allometric equation with 1.001 and the highest was found in branches (1.008). The observed value of the different tree components of biomass, total aboveground biomass, belowground biomass and total biomass were fitted to the predicted values

using the allometric equations that was developed (Figure 4).

The results of this study are significant in the assessment of biomass and carbon stocks in the pitch pine forests of South Korea. Furthermore, the developed allometric equations can be applied to estimate the pitch pine forests total biomass in South Korea using the 5th National Forest Inventory data.

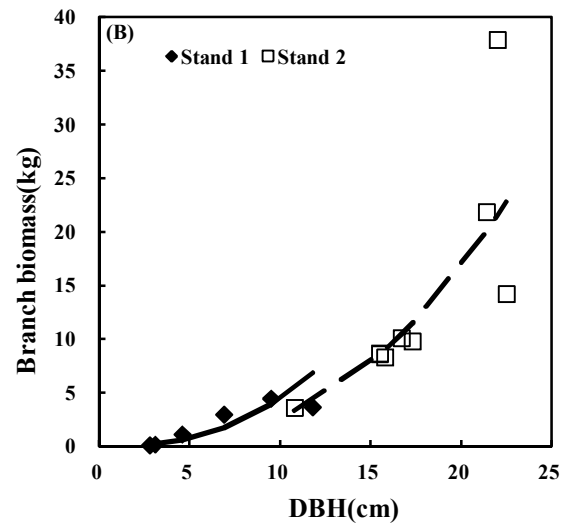
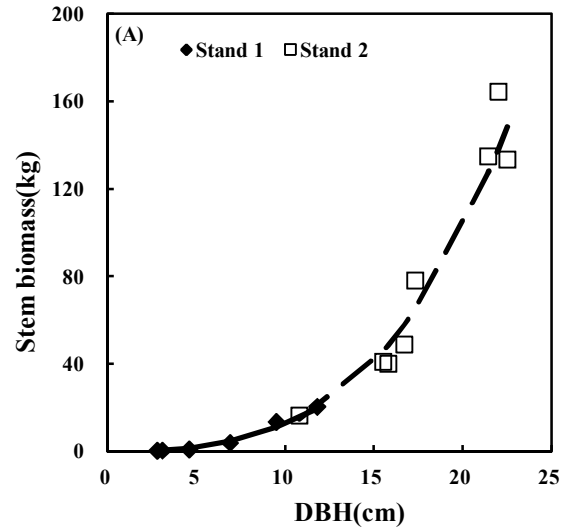

Acknowledgements:

This research was supported by the Basic Science Research Program through the National Research Foundation of Korea (NRF), funded by the Ministry of Education, Science and Technology (2012.0004519).

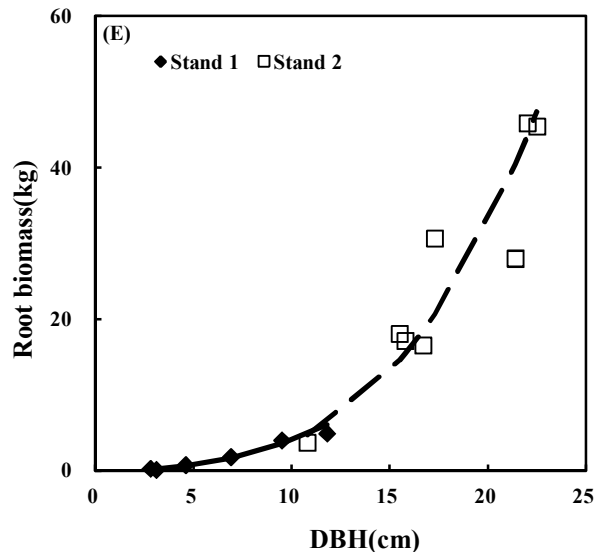
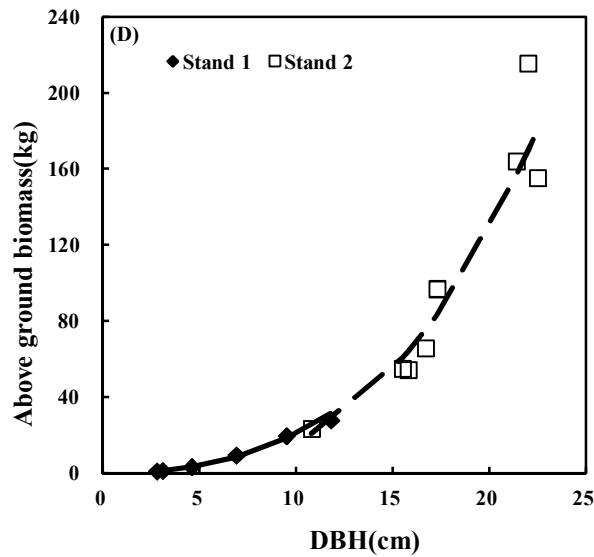
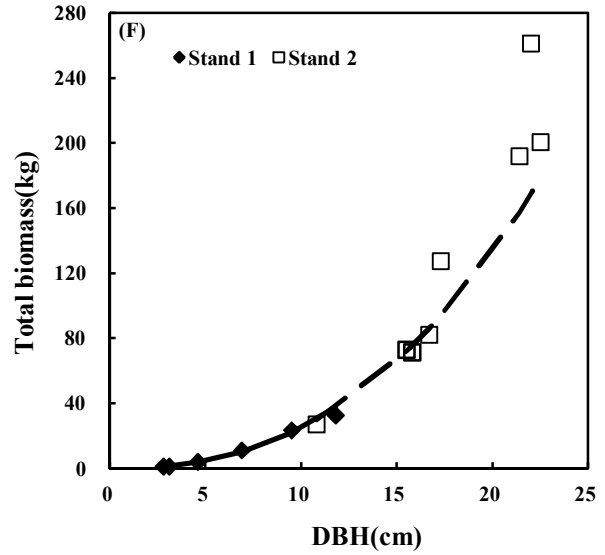
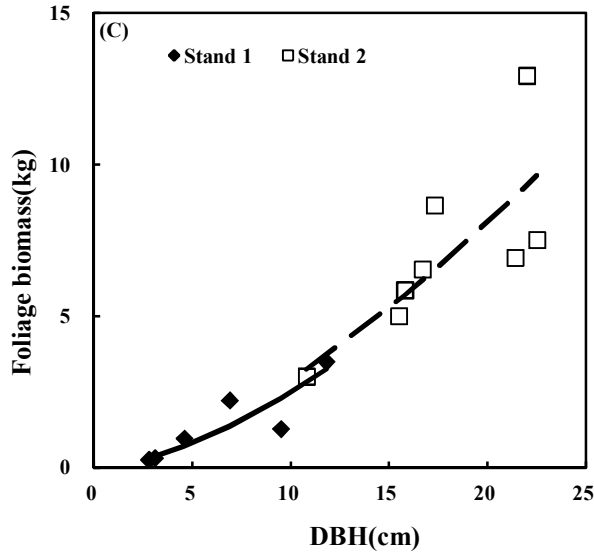

Figure 4. Relationships between the biomass and DBH in two stand age classes of *Pinus rigida* in South Korea.

Corresponding Author:

Dr. Young Jin Lee
 Department of Forest Resources,
 Kongju National University,
 Yesan, Chungnam 340-802, South Korea
 E-mail address: leeyj@kongju.ac.kr

References

- Basuki TM, Van Laake PE, Skidmore AK, Hussin YA. Allometric equations for estimating the above-ground biomass in tropical lowland Dipterocarp forests. *Forest Ecology and Management* 2009; 257:1684-1694.
- Bollandsas OM, Rekstad I, Naeset E, Rosberg I. Models for predicting above-ground biomass of *Betula pubescens* spp. *czerepanovii* in mountain areas of southern Norway. *Scandinavian Journal of Forest Research* 2009;24:318-332.
- Cairns MA, Brown S, Helmer EH, Baumgardner GA. Root biomass allocation in the world's upland forests. *Oecologia* 1997;111:1-11.
- Chung SY, Yim JS, Cho HK, Jeong JH, Kim SH, Shin MY. Estimation of forest biomass for Muju county using biomass conversion table and remote sensing data. *Journal of Korean Forest Society* 2009;98(4):409-416 (in Korean with English abstract).
- Dixon RK, Trexler MC, Wisniewski J, Brown S, Houghton RA, Solomon AM. Carbon pools and flux of global forest ecosystems. *Science* 1994;263:185-190.
- Fehrmann L, Lehtonen A, Kleinn C, Tomppo E. Comparison of linear and mixed-effect regression models and k-nearest neighbor approach for estimation of single-tree biomass. *Canadian Journal of Forest Research* 2008;38(1):1-9.

7. Hosoda K, Iehara T. Aboveground biomass equations for individual trees of *Cryptomeria japonica*, *Chamaecyparis obtuse* and *Larix kaempferi* in Japan. *Journal of Forest Research* 2010;15:299–306.
8. IPCC. Guidelines for national greenhouse gas inventories, prepared by the National Greenhouse Gas Inventories Programme. H. S. Eggleston, L. Buendia, K. Miwa, T. Ngara & K. Tanabe (Eds.). Japan: IGES. 2006.
9. Kim CS. Aboveground nutrient distribution in Pitch pine (*Pinus rigida*) and Japanese Larch (*Larix leptolepis*) plantations. *Journal of Korean Forest Society* 1999;88(2):266-272 (in Korean with English abstract).
10. Kim C, Jeong J, Kim RH, Son YM, Lee KH, Kim JS, Park IH. Allometric equations and biomass expansion factors of Japanese red pine on the local level. *Landscape and Ecological Engineering* 2011;7:283–289.
11. Koch P. Estimates by species group and region in the USA of below ground root weight as a percentage of over-dry complete-tree weight and carbon content of tree portions. *Wood Science Laboratory, Inc., Corvallis, MT.* 1989;23.
12. Korea Forest Research Institute (KFRI). Survey manual for forest biomass. 2006;p51 (in Korean).
13. Korea Forest Research Institute (KFRI). Management plan on greenhouse gas absorption and emission factor in Korea. 2008 (in Korean).
14. Korea Forest Service. <http://www.forest.go.kr/>. 2010.
15. Kwon KC, Lee DK. Biomass and energy content of *Pinus rigida* stand in Gwangju, Gyeonggi province. *Journal Korean Forest Energy* 2006;25(1):39-45 (in Korean with English abstract).
16. Lee DK. Korean Forests: Lessons learned from stories of success and failure. Published by Korea Forest Research Institute, 2010;7-8.
17. Lehtonen A, Makipaa R, Heikkinen J, Sievanen R, Liski J. Biomass expansion factors (BEFs) for Scots pine, Norway spruce and birch according to stand age for boreal forests. *Forest Ecology and Management* 2004;188:211-224.
18. Li X, Yi MJ, Son Y, Park PS, Lee KH, Son YM, Kim RH, Jeong MJ. Biomass expansion factors of natural Japanese Red Pine (*Pinus densiflora*) forests in Korea. *Journal of Plant Biology* 2010a;53:381–386.
19. Li X, Yi MJ, Son Y, Jin G, Han SS. Forest biomass carbon accumulation in Korea from 1954 to 2007. *Scandinavian Journal of Forest Research* 2010b; 25:554-563.
20. Lim JH, Shin JH, Jin GZ, Chun JH, Oh JS. Forest stand structure, site characteristics and Carbon budget of the Kwangneung natural forest in Korea. *Journal of Agricultural and Forest Meteorology* 2003;5(2):101-109 (in Korean with English abstract).
21. Mirov NT. The Genus *Pinus*. Ronald press Co. New York, 1967;pp.602.
22. Noh NJ, Son Y, Lee SK, Seo KW, Heo SJ, Yi MJ, Park PS, Kim RH, Son YM, Lee, KH. Carbon and nitrogen storage in an age-sequence of *Pinus densiflora* stands in Korea. *Science China Life Sciences* 2010;53(7):822-830.
23. Peichl M, Arain MA. Allometry and partitioning of above- and belowground tree biomass in an age-sequence of white pine forests. *Forest Ecology and Management* 2007;253:68-80.
24. SAS Institute Inc. SAS/STAT 9.1 User's Guide. SAS Institute Inc., Cary. NC. 2004.
25. Seo YO, Lee YJ, Lee MH, Park SM, Park IH, Son Y, Son YM, Lee KH. Estimation of above and belowground biomass for Pitch pine (*Pinus rigida*) planted in Yesan. *Korean Journal of Forest Measurement* 2006;9:1-9 (in Korean with English abstract).
26. Son Y, Kim HW. Above-ground biomass and nutrient distribution in a 15-year-old Ginkgo (*Ginkgo biloba*) plantation in central Korea. *Bioresource Technology* 1998;63:173-177.
27. Son Y, Hwang JW, Kim ZS, Lee WK, Kim JS. Allometry and biomass of Korean pine (*Pinus koraiensis*) in central Korea. *Bioresource Technology* 2001;78:251-255.
28. Sprugel DG. Correction for bias in log transformed allometric equation. *Ecology* 1983;64(1):200-210.
29. Teobaldelli M, Somogyi Z, Migliavacca M, Usoltsev V. Generalized functions of biomass expansion factors for conifers and broadleaved by stand age, growing stock and site index. *Forest Ecology and Management* 2009;257:1004–1013.
30. Tobin B, Nieuwenhuis M. Biomass expansion factors for Sitka spruce (*Picea sitchensis* (Bong.) Carr.) in Ireland. *European Journal of Forest Research* 2007;126:189–196.
31. Watson RT, Novel IR, Bolin B, Ravindranath NH, Verardo DJ, Dokken DJ. *Land Use, Land-Use Change, and Forestry*. Cambridge University Press. 2000;pp. 21.
32. Whittaker RH, Marks PL. Methods of assessing terrestrial productivity. In: Lieth H, Whittaker R H, eds. *Primary Productivity of the Biosphere*. New York: Springer-Verlag. 1975;55-118.
33. Xiao CW, Ceulemans R. Allometric relationships for below- and aboveground biomass of young Scots pines. *Forest Ecology and Management* 2004;203:177-186.

1/26/2012

Assessment of Antifungal Activity of Chitinase Produced by *Bacillus licheniformis* EG5 Isolated from Egyptian Soil

Abdel-Shakour E. H.

Botany and Microbiology Department, Faculty of Science, Al-Azhar University, Cairo, Egypt
essam_hussain@hotmail.com

Abstract: The chitinolytic activity of the isolate *B. licheniformis* EG5 obtained from agricultural Egyptian soil was investigated. This isolate degraded chitin with the development of distinct zone of clearance on colloidal chitin agar. The isolate was identified by classical bacteriological examination, metabolic fingerprinting using Biolog Micro Plates and phylogenetic analysis of 16S ribosomal RNA gene nucleotide sequence. Evaluation of antifungal activity of the produced enzyme was done and revealed the potential antifungal activity especially against *F. graminearum* (NRRL 5883) & *F. sp.* (NRRL 37262) among strains of *Fusarium* tested. Chitinase enzyme from the isolate under study was produced under the determined optimum conditions. These conditions were static incubation for three days at initial pH 8.00 & incubation temperature 40°C with chitin concentration 0.7 % (w/v). Under these conditions, the enzyme activity in culture supernatant was 6.18 U mL⁻¹. Purification of the produced enzyme was performed and the results revealed that the enzyme activity recorded, 11.35 U mL⁻¹, had increased by about factor of two. Chitinolytic activity of the partially purified enzyme was examined again in contrast to controls maintained with heat inactivated enzyme which did not record any chitinolytic zones. Final assessment of antifungal activity of the partially purified chitinase produced by this isolate was confirmed against controls inoculated and maintained with heat inactivated enzyme which also did not show any activity against *Fusarium* spp. tested. Molecular weight determination revealed the presence of one distinct band of about 63 KDa.

[Abdel-Shakour E. H. **Assessment of Antifungal Activity of Chitinase Produced by *Bacillus licheniformis* EG5 Isolated from Egyptian Soil.** *Life Sci J* 2012;9(4):3560-3572] (ISSN:1097-8135). <http://www.lifesciencesite.com>. 527

Keywords: Antifungal activity; Chitinase; *Bacillus licheniformis*; Production optimization; Soil

1. Introduction

Bacillus spp., the most often isolated bacteria from natural environments, have been used widely in agricultural applications. Biopesticides, whereby a natural organism or its' metabolites are used as the controlling agent, are the material basis and an important means of pesticidal control (Marc and Philippe, 2007). For example, the fungicides Serenade and Sonata that are made of *B. subtilis* QST713 and QST2808 have been registered and applied in America (Cao *et al.*, 2010). Yin *et al.* (2011) indicated that *B. amyloliquefaciens* PEBA20 has the potential to serve as a biological control agent for the poplar canker disease caused by *Botryosphaeria dothidea* and for diseases caused by other phytopathogens. Li *et al.* (2012) indicated that *Bacillus subtilis* ZZ120 showed strong growth inhibition activity *in-vitro* against the replant disease phytopathogens *Fusarium graminearum*, *Alternaria alternata*, *Rhizoctonia solani*, *Cryphonectria parasitica* and *Glomerella glycines*. The antifungal compounds were isolated from n-butanol extract as a mixture of iturins.

Bacillus licheniformis is a Gram-positive, spore-forming soil bacterium that is used in the biotechnology industry to manufacture enzymes, antibiotics, and biochemical and consumer products.

This species is closely related to the well studied model organism *Bacillus subtilis*, and produces an assortment of extracellular enzymes that may contribute to nutrient cycling in nature. Chitin is the second most abundant polysaccharide in nature, next to cellulose. It is composed of (1-4)- β -linked N-acetyl-D-glucosamine (NAG) subunits and is an important component of both carbon and nitrogen cycles. This polysaccharide compound can be found in fungi, insect exoskeletons, and marine invertebrates (Huang *et al.*, 2005). The initial step in microbial chitin degradation is usually the chitinase-mediated hydrolysis of the polymer into monomers and oligomers. Since, chitin is a major cell wall constituent of fungi, therefore, chitinases, the hydrolytic enzymes that specifically degrade chitin, are gaining much attention worldwide (Wang *et al.*, 2006).

Chitinases are found in a broad range of organisms (fungi, bacteria, parasites, plants, insects and yeast) and play different roles in their origin. In microorganisms, chitinase has been found as biocontrol agents for different types of fungal diseases of plants (Huang *et al.*, 2005). This enzyme is used in many fields such as pest control, pollution abatement and commercial biology (Felse and Panda, 2000). Chitinases (EC 3.2.1.14) are produced by

several bacteria. These chitinases are used in various applications such as biological control of fungal pathogens (Chang *et al.*, 2007). Microorganisms produce chitinase primarily for assimilation of chitin as carbon and/or nitrogen source. Chitinases have been isolated from variety of bacteria including *Bacillus* spp. and some of them are reported to produce multiple forms of chitinases with different molecular masses. Previous reports have shown that species of *Bacillus* including *B. licheniformis* are known to produce chitinolytic enzymes (Waldeck *et al.*, 2006 & Chang *et al.*, 2007).

So, the aim of the current study was to isolate and investigate a chitinolytic bacterium and determine its potential as a biological control agent active against fungi. Mainly, chitinolytic action was concerned due to the great potential of chitinases as biological control agents. Also, production optimization for such enzymes was concerned.

2. Material and Methods

2.1 Preparation of colloidal chitin

Colloidal chitin was prepared from the chitin flakes (Crab shell chitin, Sigma Chemicals Company, USA) by the method of Mathivanan *et al.* (1998). The chitin flakes were ground to powder and added slowly to 10 N HCl (10 % percentage) and kept overnight at 4°C with vigorous stirring. The suspension was added to cold 50% ethanol with rapid stirring and kept overnight at 25°C. The precipitate was collected by centrifugation at 10,000 rpm for 20 min and washed with sterile distilled water until the colloidal chitin became neutral (pH 7.0). It was freeze-dried to powder and stored at 4°C until further use.

2.2 Soil sampling, isolation, and culture conditions

The soil samples were collected aseptically from the upper most 0-5 cm soil layer of different agricultural fields in Giza governorate, Egypt. About 1.0 g of soil sample was transferred to 99.0 ml sterilized normal saline in 250 ml conical flask and agitated (100 rpm) at 30°C for 15 minutes on water bath shaker (Eyela, Japan). The soil suspension was then diluted in serial up to 10⁻⁷ dilutions. One ml of each dilution was poured into Petri plates containing modified colloidal chitin agar (CCA) medium described by Hsu & Lockwood (1975). The medium composed of (g/L): Chitin (5 g of the dry preparation, or the equivalent volume of colloidal chitin suspension to give about 5 g of chitin per liter); Yeast extract, 0.5; NaNO₃, 2.0; K₂HPO₄ (anhydrous basis), 1.0; MgSO₄.7H₂O, 0.5; KCl, 0.5; FeSO₄.7H₂O, 0.01 and tap water, 1000 ml (pH 7.0). The inoculated plates were then incubated at 30°C and checked regularly for five days for the presence of zones of

clearance around the developed bacterial colonies. The best bacterial isolate capable of degrading chitin with the largest distinct zone of clearance on CCA was selected. Pure culture of this isolate (referred to as EG5) was maintained in Luria-Bertani broth (LBB), amended with 20% glycerol & 0.5% chitin, and stored at -80°C. Also, agar slant cultures of the same isolation medium and another set on LB slants for this bacterial isolate was stored at 4°C for regular testing and subculturing. Also, colloidal chitin of the same composition above was used for the next experiments used for cultivation and enzyme production and assay of activity.

2.3 Detection of chitinase activity *in-vitro* for the isolate EG5

This test was performed with the culture supernatant of the selected isolate using agar well diffusion method. The isolate was grown in 0.5 % colloidal chitin. One ml inoculum with 0.5 OD was used to inoculate 50 ml of medium and incubated at 30°C. After three days of incubation, the culture was harvested, centrifuged at 10,000 rpm for 15 min at 4°C and the supernatant was collected. Colloidal chitin (0.5%) agar plates were prepared and wells were made using 1 cm sterile cork borer. Culture supernatant was placed at 100 µl in each well and incubated at 30°C. After 12 h, the development of clear zone around the well was observed and recorded in triplicates. Also, the same culture supernatants were used to detect the potential antimicrobial activities as described briefly below.

2.4 Detection of chitinase antimicrobial activity for the isolate EG5

For assessment of potential antifungal activity of chitinase under study, using agar well diffusion test according to Taechowisan *et al.* (2003), a wide range of fungal strains (listed below), especially *Fusarium* spp. were used, as well as, some common bacterial strains. The bacteria and filamentous fungi were cultured on nutrient agar (NA) medium and potato dextrose agar (PDA) medium, respectively. The agar plates were incubated at 35°C for 24 h (bacteria) and at 25°C for 3 days (fungi). The yeast, *C. albicans* were grown in yeast peptone dextrose (YPD) agar at 30°C. Inhibition of microbial growth was assessed on the basis of presence or absence of an inhibition zone around the agar wells created in the previous used media using 1 cm sterile cork borer. Each well was contained about 100 µl of the culture supernatant mentioned above of the isolate EG5. All plates were kept at 4°C for at least three hours before incubation at the specified temperature. The inhibition zone in each case was measured as the distance from edge of the created

agar well till the boundary of inhibition zone (An average of three replicates). The following microbial cultures were used as test strains:

2.4.1 Bacteria: *Bacillus subtilis* (NCTC 10400), *Staphylococcus aureus* (NCTC 7447), *Escherichia coli* (NCTC 10416), & *Pseudomonas aeruginosa* (ATCC 10145).

2.4.2 Fungi: *Candida albicans* (IMRU3669), *Aspergillus niger* (LIV131), *Aspergillus flavus* (NRRL 6541), *Fusarium graminearum* (NRRL 5883), *Fusarium pseudograminearum* (NRRL 28062), *Fusarium cerealis* (NRRL 25491), *Fusarium acuminatum* (NRRL 29154), *Fusarium mesoamericanum* (NRRL 25797), *Fusarium acaciae-mearnsii* (NRRL 26752), *Fusarium asiaticum* (NRRL 6101), *Fusarium tucumaniae* (NRRL 34546), *Fusarium virguliforme* (NRRL 34552), and *Fusarium* sp. (NRRL 37262).

2.5 Identification of the isolate EG5

For the purpose of identification, the isolate EG5 was subjected for metabolic fingerprinting (using Biolog plate 3rd generation) in addition to some essential identification tests according to Logan and De Vos (2009). In addition, the isolate was identified by phylogenetic analysis of 16S ribosomal RNA gene nucleotide sequence using *16S rDNA* as the template for PCR amplification of the 16S rRNA gene.

2.5.1 Biolog Identification

Before inoculation into Biolog MicroPlate the isolate was grown at 30°C on LB agar. When sufficient plate growth was noted, the isolate was suspended in 0.85% saline and inoculated into Biolog MicroPlate (150 µl per well) according to the manufacturer's instructions and incubated for 24 hours at 30°C. Biolog plates were read using semi-automated Biolog Microstation System and Biolog software. Biolog microbial identification system using the powerful new GENIII redox chemistry is applicable to an extraordinary range of both gram negative and gram positive bacteria. This work was supported by "Research Services O" (Nasr City, Cairo, Egypt).

2.5.2 Molecular identification of *16S rDNA* gene for the isolate EG5

2.5.2.1 DNA extraction, PCR amplification and purification

The isolate EG5 was inoculated into 5 mL aliquots of LBB and incubated at 30°C on a rotary shaker at 180 r/min for 16-18 h. Total genomic DNA for PCR amplification of *16S rDNA* sequence was

extracted from the EG5 isolate according to the used kit's instruction manual (QIAamp DNA mini kit cat number, 51304). The *16S rDNA* region was amplified (approx 1500 bp) by polymerase chain reaction (PCR) using the forward primer P3 5'-AGAGTTTGATCMTGGCTCAG-3' and the reverse one P5 5'-TACGGYTACCTTGTTACGACTT-3' according to Moreno *et al.* (2002) and Yin *et al.* (2011). The PCR mixtures were prepared in 50 µl volumes containing 0.5 µM of primer, 200 mM of deoxyribonucleotide triphosphate, 5 µl of the 10X PCR buffer (100 mM Tris-HCl, 15 mM MgCl₂, 500 mM KCl; pH 8.3), 1 U of Taq DNA polymerase (Tianwei), and 1 µl of the extracted DNA. DNA amplification was performed in TProfessional Basic Thermocycler PCR system with an initial denaturation at 94°C for 5 min followed by 30 cycles of denaturation at 94°C for 60 s, annealing at 58°C for 60 s, elongation at 72°C for 90 s, and a final extension at 72°C for 10 min. The amplicon was identified by horizontal electrophoresis on 1% agarose gel against the used DNA size marker (UMR-100) and finally was purified using PCR purification kit (Tianwei). This work was supported by "Research Services O" (Nasr City, Cairo, Egypt).

2.5.2.2 *16S rDNA* gene Sequencing, data analysis and phylogeny

Sequencing was performed using an Applied Biosystems 310 sequencer (ABI 310 DNA sequencer, Big Dye Terminator cycle sequencing ready kit applied biosystems) and the same primers used for PCR. The sequence was compared with similar sequences retrieved from DNA databases by using the NCBI n-BLAST search program in the National Center for Biotechnology Information (NCBI) and aligned with ClustalW (Ver.1.74) program (Thompson *et al.*, 1994). The nucleotide distances were estimated considering alignment gaps by using Jukes and Cantor (1969) method for correction of superimposed substitutions using the Molecular Evolutionary Genetics Analysis (MEGA) software (Ver. 4.0) (Tamura *et al.*, 2007). Neighbour Joining (NJ) implemented through MEGA 4.0 software and bootstrap analysis (1000 replicates) was performed to assess the reliability of the constructed phylogenetic tree.

2.6 Chitinase activity assay and protein content determination

The activity of enzyme produced as a result of the cultivation as described above in colloidal chitin was assayed in the following manner. Extracellular chitinase activity was determined by incubating 1 ml of crude enzyme (culture supernatant) with 1 ml of 0.5% colloidal chitin in a

0.05M phosphate buffer, pH 7.0 at 30°C for 1 h. After centrifugation of reaction mixture, the amount of N-acetyl-D-glucosamine released in the supernatant was determined by the method of Reissig *et al.* (1955). The reaction was terminated by adding 0.1 ml of 0.08 M potassium tetraborate, pH 9.0 to 0.5 ml of reaction mixture and then boiled in water bath for 3 min. Then 3 ml of diluted *p*-dimethylaminobenzaldehyde (Sigma, USA) reagent was added and again incubated at 30°C for 15 min. The released product in the reaction mixture was read at 585nm in UV/VIS spectrophotometer against the blank prepared with distilled water without the enzyme presence. Chitinase activity was determined using N-acetylglucosamine (Sigma Chemicals Company, USA) as the standard. One unit (U) of chitinase activity was expressed as the amount of enzyme which released 1 μ mole of N-acetyl-D-glucosamine or its equivalent per min from colloidal chitin in 1 ml of reaction mixture under standard assay conditions (Mathivanan *et al.*, 1998). Also, the total protein concentration of the supernatant sample was determined and expressed as mg per ml using the procedure of Lowry *et al.* (1951) with bovine serum albumin as a standard. In each case, the recorded values were averages of three replicates.

2.7 Enzyme production optimization

Effect of different incubation factors on the production of chitinase enzyme by the isolate under study was conducted. The variables tested were the incubation period, aerobic incubation under static and shaking conditions, incubation temperature, the pH of the culture medium, and different concentrations of the used substrate under study. The above cultivation medium (colloidal chitin) was used and at the end of incubation, both enzyme activity and the protein concentrations, for each culture under the tested variable were determined. In each case, for testing a different variable the initial state used for isolation was kept constant. The incubation under static and shaking conditions (100 & 200 rpm) at 30°C for five days was tested first. Then, the incubation period was conducted for 1, 2, 3, 5 and 7 days. The effect of different pH values (5, 6, 7, 8 & 9), and temperature range (10, 20, 30, 40 & 50°C) on chitinase production was conducted. Also, the substrate concentrations tested of the used substrate (Colloidal Chitin) were 0.1, 0.3, 0.5, 0.7 & 0.9 % (w/v).

2.8 Enzyme production and purification

Chitinase enzyme from the isolate under study was then produced under the determined optimum conditions. Purification of the produced enzyme was then performed according to the method suggested by Nawani and Kapadnis (2001). The

culture filtrate (500 mL) of 72-h old culture broth was subjected to precipitation with ammonium sulphate up to 80% saturation and kept at 4°C for 24 h. The precipitate thus obtained was collected by centrifugation at 10,000 g for 20 min. The pellet was dissolved in a 0.05M phosphate buffer, pH 7.0 and extensively dialyzed against the same buffer. The protein concentrate was loaded on Sephadex G-100 (Sigma, USA) column (2x40 cm) pre-equilibrated with a 0.05M phosphate buffer, pH 7.0 and eluted with the same buffer. Fractions thus collected were tested for chitinolytic activity *in-vitro*, as described above. Chitinolytic active fractions were recovered, concentrated and then refrigerated at 4°C until further analysis. This partially purified enzyme was then subjected to enzyme activity and protein concentration determinations as described above. In addition, assay of chitinolytic activity, inhibition of fungal growth, and molecular weight determination were all followed up as described briefly below.

2.9 Assay of chitinolytic activity of the purified chitinase from the isolate EG5

Chitinolytic activity of the partially purified enzyme was examined by agar well diffusion method as described before. Chitinase enzyme (100 μ l) was loaded onto the wells of CC agar plates. Control was maintained with (100 μ l) of heat inactivated enzyme (5-min boiled). Chitinolytic zones around the wells were observed after 12-24 h of incubation at 30°C.

2.10 Inhibition of fungal growth by the purified chitinase from the isolate EG5

For final assessment of antifungal activity of chitinase of the isolate EG5, agar well diffusion test according to Taechowisan *et al.* (2003), was used again against only *Fusarium* spp. (listed above). They were cultured on potato dextrose agar (PDA) medium. Chitinase enzyme (100 μ l) was placed in wells of the PDA plates. Controls were also maintained with (100 μ l) of heat inactivated enzyme (5-min boiled). All plates were kept at 4°C for three hours before incubation at 25°C for 3 days to observe inhibition of fungal growth.

2.11 Molecular weight determination of the purified chitinase from the isolate EG5

The molecular weight of chitinase enzyme obtained from the isolate under study was determined by using sodium dodecyl sulphate – poly acrylamide gel electrophoresis (SDS-PAGE) technique according to Laemmli (1970). This was carried out in a 2 mm slab gel of 10% acrylamide in Tris-HCl buffer (pH 8.0) containing 0.1% SDS. After electrophoresis, the gel was stained with 0.025% Coomassie brilliant blue R-250. The gel was destained with a solution (10%

v/v glacial acetic acid and 30% v/v methanol in distilled water) till a clear background of the gel was obtained. The bands were then compared with standard proteins marker (Bio-Rad, USA) and photographed.

3. Results

3.1 The isolate EG5

From the collected soil samples, twenty five different bacterial isolates were obtained based on their chitinolytic ability on colloidal chitin agar (CCA). Only one isolate was selected to carry out the current investigation due to its promising activity. This isolate was designated as the most chitinolytic active isolate among all the obtained isolates and also sought preliminary to belong to *Bacillus subtilis* group species. This isolate degraded chitin with the development of distinct zone of clearance on CCA reached to about 25 mm in diameter.

3.2. *In vitro* chitinase & antimicrobial activity of the isolate EG5

Chitinase activity was tested along with antimicrobial activity of this enzyme using the same culture supernatant (100 µl) of this isolate grown in 0.5 % colloidal chitin after three days of incubation. Agar well diffusion method was used in each case, and, the development of clearance and inhibition zones around the wells were observed and recorded. The enzyme degraded chitin with the development of distinct zone of clearance on CCA reached to about 18 mm in diameter. Also, inhibition of microbial growth was assessed on the basis of presence or absence of an inhibition zone around the agar wells. Table (1) shows the results of this test in order of decreasing activity against the tested microbial strains. The recorded data obviously reveal the potential antifungal activity especially against strains of *Fusarium* tested. Also, while the data represent means of three replicates, any diameters less than 3mm were neglected. This is was obvious through the absence of any appropriate activities against bacterial strains. The largest inhibition zone, reached to 16 mm in diameter, was recorded against *F. graminearum* (NRRL 5883) & *F. sp.* (NRRL 37262).

3.3 Identification of the isolate EG5

Classical morphological & physiological bacteriological tests revealed that the isolate was characterized by positive Gram's stain reaction and normal rod shaped, without curved, filaments or coccoid cells. Central ellipsoidal endospores were produced and facultative anaerobic potential was recorded, but, no strict anaerobic conditions were required for growth. Motility, catalase, acid from glucose (without gas production), nitrate reduction &

denitrification, and Voges-Proskauer test were all positive. Based on these tests, the isolate was strongly recommended to belong to *Bacillus subtilis* group especially *B. licheniformis* due to the ability of anaerobic growth.

3.3.1 Biolog Identification

Also, the isolate EG5 was subjected for metabolic fingerprinting using GENIII Biolog plates read using Biolog software. Metabolic fingerprint obtained from Biolog identification plate for the isolate EG5 revealed 99% similarity percentage to *B. licheniformis*. As shown in table (2), GENIII dissects and analyzes the ability of the cell to metabolize all major classes of biochemicals, in addition to determining other important physiological properties such as pH, salt & lactic acid tolerance, reducing power, and chemical sensitivity.

3.3.2 Molecular identification of 16S rDNA gene for the isolate EG5

PCR amplification of the 16S rDNA gene produced the expected amplicon size of approximately 1500 bp (Figure 1). The partial nucleotide sequence of isolate EG5 16S rDNA gene (370 nucleotides) was compared with similar sequences retrieved from DNA databases by using the NCBI n-BLAST search program in the National Center for Biotechnology Information (NCBI) and was multiple-aligned at the same partial sequences of 8 reported *Bacillus* sequences in GenBank using ClustalW program with minor manual adjustments, resulting in 370 positions including the gaps (Figure 2). A phylogenetic tree was generated using the Neighbour-Joining method and bootstrap analysis of 1000 repetitions (Figure 3). It was revealed that the bacterium belonged to the genus *Bacillus* and was closely clustered together with *Bacillus licheniformis*. The amplified 16S rDNA gene sequence of isolate EG5 was most closely related to that of *B. licheniformis* B16 (GenBank accession number, JX112647) and showed 99.7% identity with the sequence from *B. licheniformis* B16. On the other hand, it was showed 99.2% identity with *B. subtilis* SCS-3 (GenBank accession number, EU257431). The sequence has been deposited in GenBank with accession number JX462644. The partial nucleotide sequence of *B. licheniformis* isolate EG5 16S rDNA gene (GenBank accession number, JX462644) revealed highest content for Guanine (G) 118 (31.9%) followed by Adenine (A) 94 (25.4%), then Cytosine (C) 89 (24.1%) and Thymine (T) 69 (18.6%). Data also showed that, C+G content was 207 (56%) and A+T content was 163 (44%). Moreover, the ratio between G+C to A+T was 1.27. On the other hand, bases composition data for *B.*

licheniformis isolate EG5 16S rDNA gene (GenBank sequences in GenBank was tabulated to determine G+C and A+T ratio (Table 3).

On the basis of the results of the classical bacteriological tests, the Biolog and the analysis of

accession number, JX462644) and 8 *Bacillus 16S rDNA* gene, it concluded that the isolate was a strain of *B. licheniformis* and was named *B. licheniformis* EG5.

Table 1. *In-vitro* chitinase antimicrobial activity of the isolate EG5

Test Strain	*Diameter of inhibition zone (mm)
<i>Fusarium graminearum</i> (NRRL 5883)	16.00
<i>Fusarium</i> sp. (NRRL 37262)	16.00
<i>Fusarium pseudograminearum</i> (NRRL 28062)	15.00
<i>Fusarium acaciae-mearnsii</i> (NRRL 26752)	15.00
<i>Fusarium cerealis</i> (NRRL 25491)	14.00
<i>Fusarium acuminatum</i> (NRRL 29154)	13.00
<i>Fusarium asiaticum</i> (NRRL 6101)	13.00
<i>Fusarium virguliforme</i> (NRRL 34552)	12.00
<i>Fusarium mesoamericanum</i> (NRRL 25797)	11.00
<i>Fusarium tucumaniae</i> (NRRL 34546)	11.00
<i>Aspergillus flavus</i> (NRRL 6541)	9.00
<i>Aspergillus niger</i> (LIV131)	7.00
<i>Candida albicans</i> (IMRU3669)	5.00
<i>Bacillus subtilis</i> (NCTC 10400)	1.00
<i>Staphylococcus aureus</i> (NCTC 7447)	1.00
<i>Escherichia coli</i> (NCTC 10416)	0.00
<i>Pseudomonas aeruginosa</i> (ATCC 10145)	0.00

*Zone diameters not include the diameter of the agar well (10 mm)

Table 2. Metabolic fingerprint obtained from Biolog identification plate for the isolate EG5

	1	2	3	4	5	6	7	8	9	10	11	12
A	Negative Control	Dextrin	D-Maltose	D-Trehalose	D-Cellobiose	Gentiobiose	Sucrose	D-Turanose	Stachyose	Positive Control	pH 6	pH 5
	-	+	+	+	+	+	+	+	-	+	+	+
B	D-Raffinose	α -D-Lactose	D-Melibiose	β -Methyl-D-Glucoside	D-Salicin	N-Acetyl-D-Glucosamine	N-Acetyl- β -D-Mannosamine	N-Acetyl-D-Galactosamine	N-Acetyl Neuraminic Acid	1% NaCl	4% NaCl	8% NaCl
	-	-	-	+	+	+	-	-	-	+	+	+
C	α -D-Glucose	D-Mannose	D-Fructose	D-Galactose	3-Methyl Glucose	D-Fucose	L-Fucose	L-Rhamnose	Inosine	1% Sodium Lactate	Fusidic Acid	D-Serine
	+	+	+	-	-	-	-	+	-	+	-	-
D	D-Sorbitol	D-Mannitol	D-Arabitol	myo-Inositol	Glycerol	D-Glucose- 6-PO4	D-Fructose- 6-PO4	D-Aspartic Acid	D-Serine	Troleandomycin	Rifamycin SV	Minocycline
	+	+	-	?	+	-	-	-	-	-	-	-
E	Gelatin	Glycyl-L-Proline	L-Alanine	L-Arginine	L-Aspartic Acid	L-Glutamic Acid	L-Histidine	L-Pyroglytamic Acid	L-Serine	Lincomycin	Guanidine HCl	Niaproof 4
	+	-	-	-	-	-	-	-	-	-	+	-
F	Pectin	D-Galacturonic Acid	L-Galactonic Acid Lactone	D-Gluconic Acid	D-Glucuronic Acid	Glucuronamide	Mucic Acid	Quinic Acid	D-Saccharic Acid	Vancomycin	Tetrazolium Violet	Tetrazolium Blue
	+	+	-	+	+	+	+	-	-	-	-	-
G	p-Hydroxy-Phenylacetic Acid	Methyl Pyruvate	D-Lactic Acid Methyl Ester	L-Lactic Acid	Citric Acid	α -Keto-Glutaric Acid	D-Malic Acid	L-Malic Acid	Bromo-Succinic Acid	Nalidixic Acid	Lithium Chloride	Potassium Tellurite
	-	?	-	+	+	-	-	+	-	-	+	+
H	Tween 40	γ -Amino-Butyric Acid	α -Hydroxy-Butyric Acid	β -Hydroxy-D,L-Butyric Acid	α -Keto-Butyric Acid	Acetoacetic Acid	Propionic Acid	Acetic Acid	Formic Acid	Aztreonam	Sodium Butyrate	Sodium Bromate
	?	?	-	-	-	-	-	-	-	+	+	-

(+): Positive reaction (-): Negative reaction (?): Positive or Negative reaction (not read)

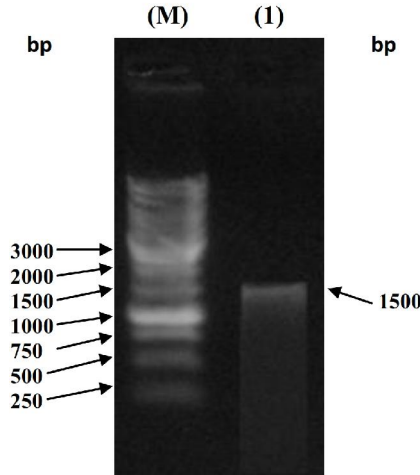

Figure 1. Agarose gel electrophoresis of amplified product of *16S rDNA* gene of the isolate EG5 (1) & the DNA size marker (M).

EG5_JX462644	ACGAACGCTG	GCGGCGTGCC	TAATACATGC	AAGTCGAGCG	GACAGAAGGG	AGCTTGCTCC	CTGATGTTAG	CGGCCGACGG
Bacillus_licheniformis_JX112647T.....
Bacillus_subtilis_EU257431C.....
Bacillus_sonorensis_JQ712166C..C.....T.G..C.....
Bacillus_pumilus_AY211128G.....
Bacillus_tequilensis_JQ619484T.....
Bacillus_amyloliquefaciens_DQ389755T.....
Bacillus_vallismortis_NR_024696T.....
Bacillus_atrophaeus_AB680855T.....
EG5_JX462644	GTGAGTAACA	CGTGGGTAAC	CTGCCTGTAA	GACTGGGATA	ACTCCGGGAA	ACCGGGGCTA	ATACCGGATG	CTTGATTGAA
Bacillus_licheniformis_JX112647A.....
Bacillus_subtilis_EU257431
Bacillus_sonorensis_JQ712166
Bacillus_pumilus_AY211128T.....G..T.....
Bacillus_tequilensis_JQ619484G..T.....
Bacillus_amyloliquefaciens_DQ389755T.....
Bacillus_vallismortis_NR_024696T.....
Bacillus_atrophaeus_AB680855T.....
EG5_JX462644	CCGCATGGTT	CAATTATAAA	AGGTGGCTTT	TAGCTACCAC	TTACAGATGG	ACCGCGGGCG	CATTAGCTAG	TTGGTGAGGT
Bacillus_licheniformis_JX112647
Bacillus_subtilis_EU257431
Bacillus_sonorensis_JQ712166
Bacillus_pumilus_AY211128AC.....C..G.....
Bacillus_tequilensis_JQ619484AC.....C..G.....
Bacillus_amyloliquefaciens_DQ389755AC.....C..G.....
Bacillus_vallismortis_NR_024696AC.....C..G.....
Bacillus_atrophaeus_AB680855AC.....C..G.....
EG5_JX462644	AACGGCTCAC	CAAGGCAACG	ATGCGTAGCC	GACCTGAGAG	GGTGATCGGC	CACACTGGGA	CTGAGACACG	GCCCAGACTC
Bacillus_licheniformis_JX112647
Bacillus_subtilis_EU257431
Bacillus_sonorensis_JQ712166
Bacillus_pumilus_AY211128G.....A.....
Bacillus_tequilensis_JQ619484
Bacillus_amyloliquefaciens_DQ389755
Bacillus_vallismortis_NR_024696T.....
Bacillus_atrophaeus_AB680855
EG5_JX462644	CTACGGGAGG	CAGCAGTAGG	GAATCTTCCG	CAATGGACGA	AAGTCTGACG
Bacillus_licheniformis_JX112647
Bacillus_subtilis_EU257431
Bacillus_sonorensis_JQ712166
Bacillus_pumilus_AY211128
Bacillus_tequilensis_JQ619484
Bacillus_amyloliquefaciens_DQ389755
Bacillus_vallismortis_NR_024696
Bacillus_atrophaeus_AB680855

Figure 2. Alignment of *16S rDNA* gene of the isolate EG5 (accession no. JX462644) and 8 *Bacillus* sequences using ClustalW program resulting in 370 positions including the gaps.

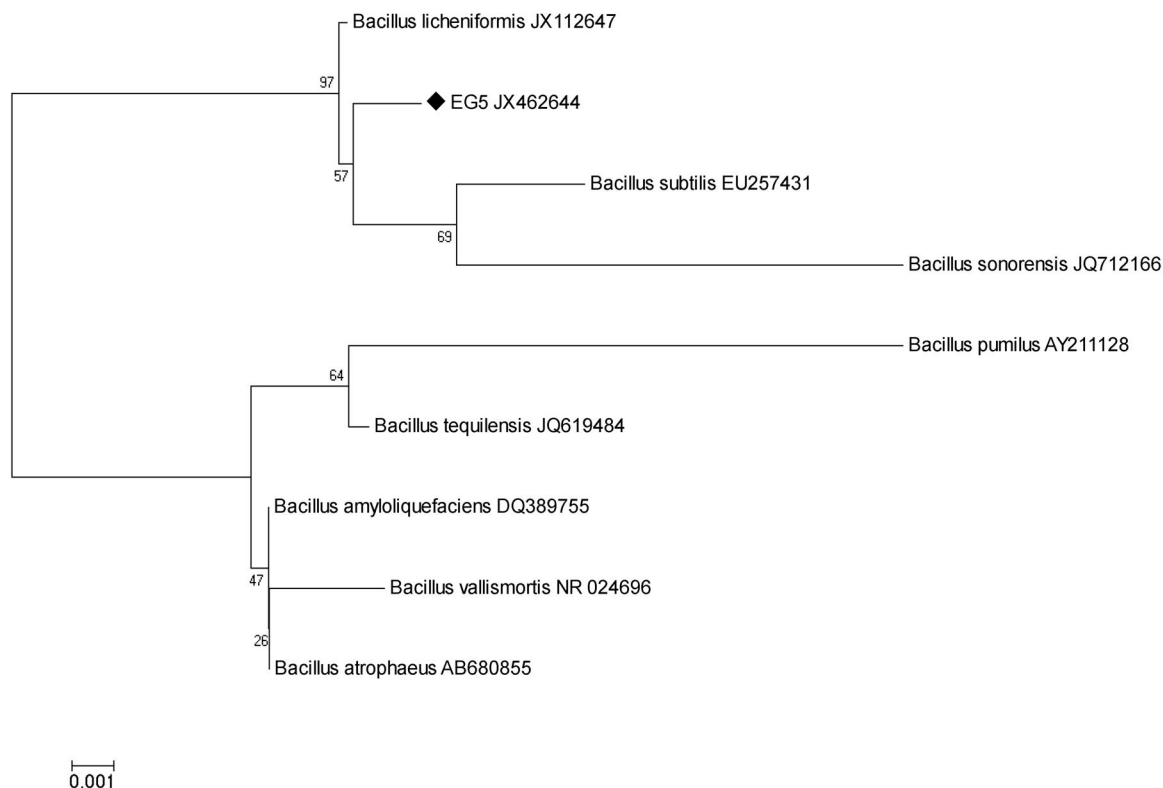

Figure 3. Neighbour-joining tree of *16S rDNA* gene of the isolate EG5 (accession no. JX462644) and 8 *Bacillus* sequences published in GenBank. Numbers represent bootstrap percentage values based on 1000 replicates.

Table 3. Comparison between bases composition of *16S rDNA* gene of the isolate EG5 (accession no. JX462644) and 8 *Bacillus* sequences published in GenBank.

Isolates	Total (bp)	A		C		G		T		G+C		A+T	
		No.	%	No.	%	No.	%	No.	%	No.	%	No.	%
EG5	370	94	25.4	89	24.1	118	31.9	69	18.6	207	56	163	44
<i>B. licheniformis</i>	370	93	25.1	89	24.1	118	31.9	70	18.9	207	56	163	44
<i>B. subtilis</i>	370	94	25.4	90	24.3	117	31.7	69	18.6	207	56	163	44
<i>B. sonorensis</i>	370	92	24.9	92	24.9	118	31.9	68	18.3	210	56.8	160	43.2
<i>B. pumilus</i>	369	93	25.2	89	24.1	121	32.8	66	17.9	210	56.9	159	43.1
<i>B. tequilensis</i>	369	92	24.9	90	24.4	120	32.5	67	18.2	210	56.9	159	43.1
<i>B. amyloliquefaciens</i>	369	92	24.9	91	24.7	119	32.2	67	18.2	210	56.9	159	43.1
<i>B. vallismortis</i>	369	92	24.9	90	24.4	119	32.2	68	18.5	209	56.6	160	43.4
<i>B. atrophaeus</i>	369	92	24.9	91	24.7	119	32.2	67	18.2	210	56.9	159	43.1

3.4 Enzyme production optimization

Effect of different incubation factors on the production of chitinase enzyme by the isolate under study was conducted. The variables tested were the incubation period, aerobic incubation under static and shaking conditions, incubation temperature, the pH of the culture medium, and different concentrations of the used substrate under study. The above cultivation medium (colloidal chitin) was used and at the end of incubation, both enzyme activity and the protein concentrations, for each culture under the tested variable were determined, and hence, the specific

activities were calculated. In each case, for testing a different variable the initial state used for isolation was kept constant. The incubation under static and shaking conditions (100 & 200 rpm) at 30°C for five days was tested first. Then, the incubation period was conducted for 1, 2, 3, 5 and 7 days. The effect of different pH values (5, 6, 7, 8 & 9), and temperature range (10, 20, 30, 40 & 50°C) on chitinase production was conducted. Also, the substrate concentrations tested of the used substrate (colloidal chitin) were 0.1, 0.3, 0.5, 0.7 & 0.9 % (w/v).

Results revealed that the incubation under static state was best where the recorded chitinase activity was 5.30 UmL^{-1} and the protein concentration was 14.70 mg mL^{-1} (Table 4). Results also revealed that the incubation period for three days was best where the recorded chitinase activity was 5.55 UmL^{-1} and the protein concentration was 14.90 mg mL^{-1} (Table 5). On the other hand, while, results in table (6) revealed that incubation at pH value 8.00 was best where the recorded chitinase activity was 5.15 UmL^{-1} and the protein concentration was 14.40 mg mL^{-1} , results in table (7) revealed that the incubation at temperature 40°C was best where the recorded chitinase activity was 5.50 UmL^{-1} and the protein concentration was 13.15 mg mL^{-1} . Finally, results revealed that growth of the isolate under study was best on colloidal chitin concentration of 0.7 % (w/v) where the recorded chitinase activity was 5.45 UmL^{-1} and the protein concentration was 13.85 mg mL^{-1} (Table 8).

3.5 Enzyme production and purification

Chitinase enzyme from the isolate under study was then produced under the determined optimum conditions. These conditions were static incubation for three days at initial pH 8.00 & incubation temperature 40°C with chitin concentration 0.7 % (w/v). Under these conditions, the enzyme activity in culture supernatant was 6.18 UmL^{-1} & the protein concentration was 12.75 mg mL^{-1} with specific activity 0.48. Purification of the produced enzyme was then performed (Table 9). The enzyme was subjected to precipitation with ammonium sulphate then collected by centrifugation and dialysis. The enzyme concentrate was loaded on Sephadex G-100 column and *in-vitro* chitinolytic active fractions were recovered and concentrated. This partially purified enzyme was then subjected to enzyme activity and protein concentration determinations. The results obtained revealed that the specific activity, 0.97 calculated for the partially purified chitinase produced by the isolate under study had increased by about factor of two, where, the recorded enzyme activity was 11.35 UmL^{-1} while the protein concentration determined reached to 11.70 mg mL^{-1} .

3.6 Assay of chitinolytic activity of the purified chitinase

Chitinolytic activity of the partially purified enzyme was examined here by agar well diffusion method again. Chitinolytic zones around the wells were developed on CC agar plates and recorded diameters reached in mean to 23 mm after 12-24 h of

incubation at 30°C . In contrast, controls maintained with heat inactivated enzyme did not record any chitinolytic zones at all.

3.7 Inhibition of fungal growth by the purified chitinase

For final assessment of antifungal activity of chitinase produced by the isolate EG5, agar well diffusion test was used also here against *Fusarium* spp. only cultured on PDA plates. Controls inoculated and maintained (with heat inactivated enzyme) for three days did not show any activity against *Fusarium* spp. tested where they showed full growth *i.e.* no inhibition zones were recorded at all. In contrast, inhibition of fungal growth against *Fusarium* spp. tested maintained with normal enzyme produced were recorded in mean diameters of inhibition zones (Table 10).

3.8 Molecular weight determination of the purified chitinase

The partially purified chitinase of the isolate EG5 exhibited a distinct protein band about 63 KDa in size (Figure 4).

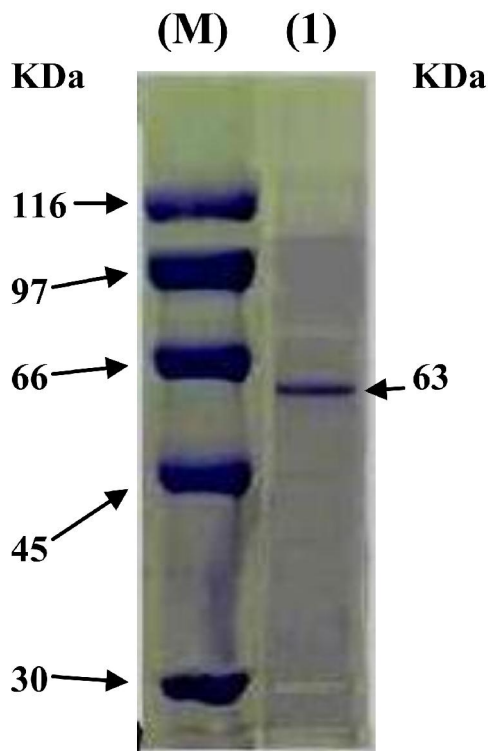

Figure 4. SDS-PAGE of chitinase produced by *B. licheniformis* EG5 (1) & the protein marker (M).

Table 4. Effect of aerobic incubation under static and shaking conditions of the culture medium on chitinase production by the isolate *B. licheniformis* EG5

Incubation condition	Enzyme activity U mL ⁻¹	Protein concentration mg mL ⁻¹	Specific activity U mg ⁻¹
Static	5.30	14.70	0.36
Shaking (100 rpm)	3.25	15.40	0.21
Shaking (200 rpm)	2.50	15.50	0.16

Table 5. Effect of the incubation period of the culture medium on chitinase production by the isolate *B. licheniformis* EG5

Incubation period days	Enzyme activity U mL ⁻¹	Protein concentration mg mL ⁻¹	Specific activity U mg ⁻¹
1	3.70	17.40	0.21
2	4.85	16.70	0.29
3	5.55	14.90	0.37
5	3.45	17.30	0.20
7	2.50	16.50	0.15

Table 6. Effect of different initial pH values of the culture medium on chitinase production by the isolate *B. licheniformis* EG5

Initial pH value	Enzyme activity U mL ⁻¹	Protein concentration mg mL ⁻¹	Specific activity U mg ⁻¹
5	1.15	16.35	0.07
6	3.90	15.20	0.26
7	4.65	14.10	0.33
8	5.15	14.40	0.36
9	1.95	15.90	0.12

Table 7. Effect of different incubation temperatures of the culture medium on chitinase production by the isolate *B. licheniformis* EG5

Incubation temperature °C	Enzyme activity U mL ⁻¹	Protein concentration mg mL ⁻¹	Specific activity U mg ⁻¹
10	0.40	13.40	0.03
20	1.80	14.20	0.13
30	4.70	15.10	0.31
40	5.50	13.15	0.42
50	4.50	15.30	0.29

Table 8. Effect of different chitin concentrations of the culture medium on chitinase production by the isolate *B. licheniformis* EG5

Chitin concentration % (w/v)	Enzyme activity U mL ⁻¹	Protein concentration mg mL ⁻¹	Specific activity U mg ⁻¹
0.1	2.35	16.70	0.14
0.3	3.25	17.65	0.18
0.5	4.45	15.10	0.29
0.7	5.45	13.85	0.39
0.9	3.90	14.60	0.27

Table 9. Purification steps of chitinase produced by the isolate EG5

Purification step	Total Volume (ml)	Total Activity (U)	Total proteins (mg)	Specific activity (U mg ⁻¹)	Purification Fold (%)	Yield (%)
Culture Supernatant	500	3090	6375	0.48	0	100
(NH ₄) ₂ SO ₄ Precipitation	419	2590	4888	0.53	1.10	83.82
Sephadex G-100	130	1476	1521	0.97	2.02	47.77

Table 10. Inhibition of fungal growth by the purified chitinase of the isolate EG5

Test Strain	*Diameter of inhibition zone (mm)
<i>Fusarium graminearum</i> (NRRL 5883)	23.00
<i>Fusarium</i> sp. (NRRL 37262)	24.00
<i>Fusarium pseudograminearum</i> (NRRL 28062)	19.00
<i>Fusarium acaciae-mearnsii</i> (NRRL 26752)	20.00
<i>Fusarium cerealis</i> (NRRL 25491)	19.00
<i>Fusarium acuminatum</i> (NRRL 29154)	18.00
<i>Fusarium asiaticum</i> (NRRL 6101)	17.00
<i>Fusarium virguliforme</i> (NRRL 34552)	16.00
<i>Fusarium mesoamericanum</i> (NRRL 25797)	16.00
<i>Fusarium tucumaniae</i> (NRRL 34546)	15.00

*Zone diameters not include the diameter of the agar well (10 mm)

4. Discussion

Bacillus licheniformis is a Gram-positive, spore-forming bacterium widely distributed as a saprophytic organism in the environment. This species is a close relative of *Bacillus subtilis*. Experiments with cultured bacterial strains suggest that chitinase activity, actively produced during exponential growth phase, mainly produces chitin dimmers (diNAG), but also chitin monomers (NAG) are being released (Horn *et al.* 2006). Beier and Bertilsson (2011) have investigated to what extent chitinolytic bacteria subsidize bacterial populations that do not produce chitinolytic enzymes but still use the products of chitin hydrolysis.

The isolate EG5 under study was selected from a number of different bacterial isolates based on chitinolytic activity on colloidal chitin agar (25 mm clearance zone on CCA). *In-vitro* chitinase activity, 18 mm clearance zone on CCA & antifungal activity 16 mm inhibition zone, mainly against *F. graminearum* (NRRL 5883) & *F. sp.* (NRRL 37262) and absence of any activities against bacteria revealed potential antifungal activity of this isolate.

Identification of the isolate EG5 based on classical bacteriological tests, Biolog metabolic fingerprinting and phylogenetic analysis of 16S rRNA gene revealed that this isolate is strongly recommended to belong to *Bacillus subtilis* group

species especially *B. licheniformis* and so, it was named *B. licheniformis* EG5.

It is well known that temperature is one of the factors influence the activity of an enzyme. Also, there is a maximum rate at which a certain amount of enzyme can catalyze a specific reaction that can be achieved when the concentration of substrate is sufficiently high. Effect of different incubation factors on the production of chitinase enzyme by the isolate under study was conducted. The variables tested were the incubation period, aerobic incubation under static and shaking conditions, incubation temperature, the pH of the culture medium, and different concentrations of the used substrate, colloidal chitin.

Chitinase enzyme from the isolate under study was produced under the determined optimum conditions. These conditions were static incubation for three days at initial pH 8.00 & incubation temperature 40°C with chitin concentration 0.7 % (w/v). Under these conditions, the enzyme activity was 6.18 U mL⁻¹ & the protein concentration was 12.75 mg mL⁻¹ with specific activity 0.48. Purification of the produced enzyme resulted in an increase in the specific activity, 0.97, by about factor of two where the recorded enzyme activity was 11.35 U mL⁻¹ & the protein concentration determined was 11.70 mg mL⁻¹.

Chitinase isolated mainly from thermophilic organisms such as *Bacillus licheniformis* and *Bacillus sp.* have found to be commercialized as they possess inherent stability (Haki and Rakshit, 2003). *Bacillus licheniformis* may produce for example 0.35 U/ml chitinase activities from colloidal chitin at 50°C (Felse and Panda, 2000). Many other studies were previously conducted and reported more or less similar activities from *Bacillus subtilis* group species such as those of San-Lang *et al.* (2002) and Yan *et al.* (2011), *B. amyloliquefaciens* V656 and *B. subtilis* SL-13 antifungal chitinase activities, respectively.

Finally, chitinolytic activity of the partially purified enzyme produced by the isolate under study was examined & chitinolytic zones developed on CCA plates recorded diameters reached in mean to 23 mm after 12-24 h of incubation at 30°C, while, controls maintained with heat inactivated enzyme did not record any chitinolytic zones at all. Final assessment of antifungal activity of chitinase produced by this isolate against *Fusarium* spp. only was recorded in this case too; (23 mm inhibition zone against *F. graminearum* NRRL 5883 & 24 mm against *F. sp.* NRRL 37262) against controls inoculated and maintained with heat inactivated enzyme that did not show any activity against *Fusarium* spp. The chitinase produced by the isolate EG5 exhibited a distinct protein band, about 63 KDa which owned the antifungal activity, in agreement with many other similar studies.

Similar studies, previously conducted, include that of Xiao *et al.* (2009) who isolated a bacterial strain secreted high levels of extracellular chitinase (4.645 U/ml) when chitin powder existed as an inducer. This strain was identified as *Bacillus licheniformis* using the Biolog MicroLog microbial identification system and sequence analysis of *16S rDNA*, *gyrA* and *rpoB* genes. This strain was able to inhibit the growth of *Gibberella saubinetii* and *Aspergillus niger*. The chitinase was proved to play an important role in this strain as antifungal activity. Also, further studies were conducted by Xiao *et al.* (2010) and revealed that the wild-type produced chitinase (55 KDa) of *Bacillus licheniformis* MY75 owned the antifungal activity.

5. Conclusion

The results obtained here addressed the potential of using chitinases as safe antifungal agents to reduce the effects of fungal pathogens on some crops. As an endospore-forming bacterium, the ability of the organism to survive under unfavorable environmental conditions may enhance its potential as a natural biocontrol agent. It can be inferred also from growth conditions of this isolate, which capable to grow under anaerobic conditions (Facultative

anaerobe; unlike most other bacilli), that it can be used in biotechnological applications for chitinous wastes bioconversions under solid state fermentation and high degrees of pH and temperatures too.

6. Future work

Results of the current study were an initiation for approving the produced enzyme by the isolate *B. licheniformis* EG5 under study by searching for the gene responsible for enzyme production and the deduced amino acid sequence of the functional protein in subsequent work.

Corresponding Author:

Dr. Essam H. Abdel-Shakour
Botany and Microbiology Department
Faculty of Science
Al-Azhar University, Cairo, Egypt
E-mail: essam_hussain@hotmail.com

References

1. Beier, S. and S. Bertilsson, 2011. Uncoupling of Chitinase activity and uptake of hydrolysis products in freshwater bacterioplankton. *Limnol. Oceanogr.*, 56 (4): 1179–1188.
2. Cao, C.X., S. Park and G.B.B. McSpadden, 2010. Biopesticide Controls of Plant Diseases: Resources and Products for Organic Farmers in Ohio. *Agric. Nat. Resour. SAG*: 18-10.
3. Chang, W.T., Y.C. Chen and C.L. Jao, 2007. Antifungal activity and enhancement of plant growth by *Bacillus cereus* grown on shellfish chitin wastes. *Bioresour. Technol.*, 98: 1224-1230.
4. Felse, P.A. and T. Panda, 2000. Production of microbial Chitinases. *Bioprocess Engineering*, 23: 127-134.
5. Haki, G.D. and S.K. Rakshit, 2003. Developments in industrially important thermostable enzymes. *Bioresour. Technology*, 89: 17-34.
6. Horn, S. J., A. SØrbotten, B. Synstad, P. Sikorski, M. SØrlie, K. M. VA° rum and V.G.H. Eijsink, 2006. Endo/exo mechanism and processivity of family 18 Chitinases produced by *Serratia marcescens*. *FEBS J.*, 273: 491–503.
7. Hsu, S.C. and J.L. Lockwood, 1975. Powdered chitin agar as a selective medium for enumeration of actinomycetes in water and soil. *Applied Microbiology*, 29: 422-426.
8. Huang, C.J., T.K. Wang, S.C. Chung and C.Y. Chen, 2005. Identification of an Antifungal Chitinase from a Potential Biocontrol Agent, *Bacillus cereus* 28-9. *Biochemistry Molecular Biology*, 38 (1): 82-88.

9. Jukes, T.H. and C.R. Cantor, 1969. Evolution of Protein Molecules. In: Mammalian Protein Metabolism, Munro, H.N. (Ed.). Academic Press, New York, pp: 21-132.
10. Laemmli, U.K., 1970. Cleavage of structural proteins during the assembly of the head of bacteriophage T4. *Nature*, 277: 680-685.
11. Li, H., X. Wang, M. Han, Z. Zhao, M. Wang, Q. Tang, C. Liu, B. Kemp, Y. Gu, J. Shuang and Y. Xue, 2012. Endophytic *Bacillus subtilis* ZZ120 and its potential application in control of replant diseases. *African Journal of Biotechnology*, 11 (1): 231-242.
12. Logan, N.A. and P. De Vos, 2009. *Bacillus*; In Bergey's Manual of Systematic Bacteriology, 2nd edn ed. De Vos, P., Garrity, G.M., Jones, D., Krieg, N.R., Ludwig, W., Rainey, F.R., Schleifer, K.-H. and Whitman, W.B. pp. 21-128 New York: Springer.
13. Lowery, O. H., N. J. Rosenbrough, A. L. Farr and R. J. Randall, 1951. Protein measurement with Folin-phenol reagent. *J. Biol. Chem.*, 193: 265-275.
14. Marc, O. and J. Philippe, 2007. *Bacillus* lipopeptides: versatile weapons for plant disease biocontrol. *Cell*, 16(3): 115-125.
15. Mathivanan, N., V. Kabilan and K. Murugesan, 1998. Purification, characterization and anti-fungal activity from *Fusarium chlamydosporum*, a mycoparasite to groundnut rust, *Puccinia arachidis*. *Can. J. Microbiol.*, 44: 646-651.
16. Moreno, C, J. Romero and R.T. Espejo, 2002. Polymorphism in repeated 16S rRNA genes is a common property of type strains and environmental isolates of the genus *Vibrio*. *Microbiol.*, 148: 1233-1239.
17. Nawani, N.N. and B.P. Kapadnis, 2001. One step purification of Chitinase from *Serratia marcescens* NK1, a soil isolate. *J. Appl. Microbiol.*, 90: 803-808.
18. Reissig, J.L., J.L. Strominger and L.F. Leloir, 1955. A modified colorimetric method for the estimation of N-acetyl amino sugars. *J. Biol. Chem.*, 27: 959-966.
19. San-Lang, W., S. Ing-Lung, L. Tze-Wun and W. Chi-Hau, 2002. Purification and characterization of two antifungal Chitinases extracellularly produced by *B. amyloliquefaciens* V656 in a shrimp and crab shell powder medium. *J. of Agricultural and Food Chemistry*, 50 (8): 2241-2248.
20. Taechowisan, T., J.F. Peberdy and S. Lumyong, 2003. Chitinase production by endophytic *Streptomyces aureofaciens* CMU Ac 130 and its antagonism against phytopathogenic fungi. *Annal. Microbiol.*, 53: 447-461.
21. Tamura, K., J. Dudley, M. Nei and S. Kumar, 2007. MEGA4: Molecular Evolutionary Genetics Analysis (MEGA) software version 4.0. *Mol. Biol. Evol.*, 24: 1596-1599.
22. Thompson, J.D., D.G. Higgins and T.J. Gibson, 1994. CLUSTAL W: Improving the sensitivity of progressive multiple sequence alignment through sequence weighting, position-specific gap penalties and weight matrix choice. *Nucleic Acids Res.*, 22: 4673-4680.
23. Waldeck, J., G. Daum, B. Bisping and F. Meinhardt, 2006. Isolation and molecular characterization of Chitinase deficient *Bacillus licheniformis* strains capable of deproteinization of shrimp shell waste to obtain highly viscous chitin. *Appl. Environ. Microbiol.*, 72(12): 7879-7885.
24. Wang, S.L., T.Y. Lin, Y.H. Yen, H.F. Liao and Y.J. Chen, 2006. Bioconversion of shellfish chitin wastes for the production of *Bacillus subtilis* W-118 chitinase. *Carbohydr Res.*, 341: 2507-2515.
25. Xiao, L., C. Liu, C.c. Xie, J. Cai, D. Liu and Y. Chen, 2010. Heterogeneous expression of Chitinase gene from *Bacillus licheniformis* MY75 and the characterization of expressed *ChiMY*. *Acta Microbiologica Sinica*, 50 (6): 749-754.
26. Xiao, L., C.c. Xie, J. Cai, Z. J. Lin and Y. H. Chen, 2009. Identification and Characterization of a Chitinase-Produced *Bacillus* Showing Significant Antifungal Activity. *Current Microbiology*, 58 (5): 528-533.
27. Yan, L., T. Jing, Y. Yujun, L. Bin, L. Hui and L. Chun, 2011. Biocontrol Efficiency of *Bacillus subtilis* SL-13 and Characterization of an Antifungal Chitinase. *Chinese Journal of Chemical Engineering*, 19 (1): 128-134.
28. Yin, X.T., L.N. Xu, L. Xu, S.S. Fan, Z.Y. Liu and X.Y. Zhang, 2011. Evaluation of the efficacy of endophytic *Bacillus amyloliquefaciens* against *Botryosphaeria dothidea* and other phytopathogenic microorganisms. *African Journal of Microbiology Research*, 5(4): 340-345.

9/7/2012

Measurements of Natural Radionuclides in Soil samples from Tourbh Governorate, Saudi Arabia

Alharbi W.R.

Physics Department, Faculty science for Girls, king Abdulaziz University, Jeddah, Saudi Arabia
Walhrbi@kau.edu.sa

Abstract The level of natural radioactivity in forty nine soil samples collected from Tourbh governorate, Saudi Arabia were measured using gamma ray spectrometer. Analyses of soil samples have been performed to determine the radioactive concentrations of ^{226}Ra , ^{232}Th and ^{40}K . The results show that these radionuclides concentrations present in Bq/kg and ranged from 1.95 ± 0.08 to 13.07 ± 0.5 , 1.33 ± 0.11 to 10.04 ± 0.61 and 39.92 ± 3.43 to 193.71 ± 16.66 for ^{226}Ra , ^{232}Th and ^{40}K respectively. To assess the radiation hazard, the radium equivalent activity (Ra_{eq}), the representative level index, I_{gr} , and absorbed dose in air for all samples were calculated. The data were discussed and compared with the published data in different countries.

[Alharbi W.R. **Measurements of Natural Radionuclides in Soil samples from Tourbh Governorate, Saudi Arabia**. *Life Sci J* 2012;9(4):3573-3577]. (ISSN: 1097-8135). <http://www.lifesciencesite.com>. 528

Keywords: Soil, Environmental Radioactivity, Gamma spectrometry, Radiation Exposure.

1. Introduction

Natural radioactive materials are the most important source of radiation exposure to humans. Although these materials contain low-level radioactivity, the accumulated dose can be high. Measurements of the radiation exposure and radiation levels have been developed recently (UNSCEAR 1988, 1993). It is well known that, natural radioactivity is presented in rocks, soil, sediment, water and fish (Parker 1967). Rocks and soil contain small quantities of the radioactive elements of U and Th with their daughter products. The concentration of these elements varies considerably depending on the soil formation (NCRP, 1975).

Soils are complex mixtures of minerals, organic compounds, and living organisms that interact continuously in response to natural and imposed biological, chemical, and physical forces. A soil not only consists of organic and inorganic compounds but also radionuclides. The naturally occurring radionuclides present in soil include ^{40}K , ^{226}Ra and ^{232}Th (Khan et al., 1998). Gamma radiation emitted from those naturally occurring radioisotopes, called terrestrial background radiation, represents the main source of irradiation of the human body and contributes to the total absorbed dose via ingestion, inhalation and external irradiation (Steinhausler 1992). Calculations by Beck (1972) suggested that 50 - 80 % of the total gamma flux at the earth's surface arises from ^{40}K , ^{238}U and ^{232}Th series in top soil.

This study determined the activity concentrations of ^{226}Ra , ^{232}Th and ^{40}K in the soil samples from Tourbh governorate, in Saudi Arabia, which locate about 130 km from El- Taef town and 120 km from El-Baha town. In order to understand the occurrence and distribution of natural radionuclides of soil samples in area under

investigation and evaluate potential health hazards; the radium equivalent activity (Ra_{eq}), the representative level index, I_{gr} , and absorbed dose in air for all soil samples were estimated to assess the contribution of this radionuclide to public exposure.

2. Materials and Methods

2.1. Soil samples collection and preparation

A total of 49 samples were collected from the Tourbh governorate which located on $21^{\circ} 12' 41.09'' \text{N}$, $41^{\circ} 38' 14.09'' \text{E}$. In order to obtain a representative sample, the soil collected at each site were thoroughly mixed together, sieved to remove stones and pebbles, and crushed to pass through a 2mm mesh sieve to homogenize it, then, the soil samples were air-dried for several days, placed in an oven at 100°C and weighed. Finally, a split of each prepared sample was packed in a bottle 250 ml polypropylene bottle; which was sealed and left for at least 4 weeks before counting by gamma spectrometry in order to ensure that radioactive equilibrium was reached between ^{226}Ra , ^{222}Rn , and ^{222}Rn progeny (Quindos 1994; El-Taher, and Madkour, 2010).

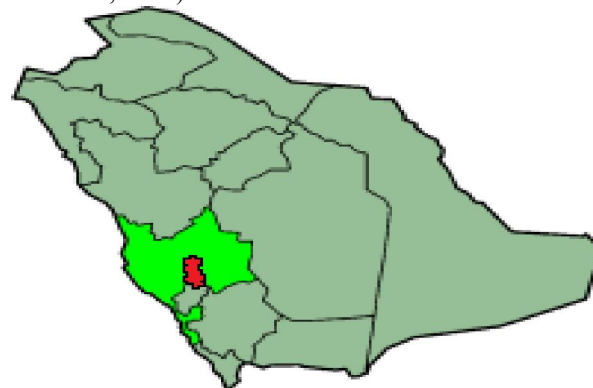

Figure (1) Saudi Arabia map include Study area (red color).

2.2. Experimental set up

Measurements had been carried out using low-level gamma ray spectrometer. It consists of "3x3" NaI (TI), S-1212-I model, with a 1024 microcomputer multichannel analyzer, 5510 Ortec Norland. The detector has a peak gamma ray efficiency of 2.3×10^{-2} at 1332 keV, energy resolution of 7.5 % at 662 keV and operation bias voltage 805 V dc. The detector was housed inside a massive cylindrical lead shield with quarter 50 cm to reduce the background radiation. The system was calibrated for energy using standard point sources (^{60}Co , ^{137}Cs), and calibrated for efficiency.

2.3. Calculations

2.3.1. Activity concentrations

Every sample was placed in face to face geometry over the detector for around 12 hour. Prior to sampling counting, background were normally taken every week under the same condition of sample measurement. The analysis of ^{226}Ra and ^{232}Th depends upon the peaks of the decay products in equilibrium with their parent nuclides. The content of ^{226}Ra was measured using gamma-lines of ^{214}Pb and 352 (37%) keV and ^{214}Bi (609.32 keV (44.6%), 1120 (15%) and 1765 (16%) keV). The concentration of ^{232}Th was determined using gamma-lines of ^{228}Ac (911.16 keV (26.6%)), and ^{212}Pb (238(43%). ^{40}K was determined by measuring its single peak at 1460.8 keV (10.67%) (El-Taher, 2010). The radioactivity concentration in the environmental samples was calculated from the following equation (1):

$$A = ((N/T) - (n/t)) / \eta MP \quad (1)$$

Where A is the activity concentration Bq/kg, N is the number of counts in a given peak area, T the sample counting lifetime, n is the number of counts in background peaks, t is the back ground counting time, P the number of gammas per disintegration of this nuclide (emission probability), M is weight in kg of the measured sample, η is the detection efficiency at measured energy.

2.3.2. Assessment of radiological hazards

2.3.2. 1. Estimation of absorbed dose rate

The conversion factors were used to compute the absorbed dose rate in air per unit of specific activity concentration in soil for ^{40}K , ^{226}Ra and ^{232}Th as in equation (2).

$$D(\text{nGy/h}) = 0.0417 C_K + 0.462 C_{Ra} + 0.604 C_{Th} \quad (2)$$

Where C_{Ra} , C_{Th} and C_K are the specific activities of ^{226}Ra , ^{232}Th and ^{40}K in Bq/kg respectively.

2.3.2. 2. Radium equivalent activity

Radium equivalent activity is an index that has been introduced to represent the specific activities of ^{226}Ra , ^{232}Th and ^{40}K by a single quantity, which takes into account the radiation hazards associated

with them. This first index can be calculated according to the following equation (3):

$$C_{eq} = C_{Ra} + (10/7) C_{Th} + (10/130) C_K \quad (3)$$

Where C_{Ra} , C_{Th} and C_K are the specific activities of ^{226}Ra , ^{232}Th and ^{40}K in Bq/kg, respectively (Beretka and Mathew 1985, Abbady 2004).

2.3.2. 3. Representative level index

Another radiation hazard index called the representative level index (I_r) is defined as follows in equation (4):

$$I_r = (1/150) C_{Ra} + (1/100) C_{Th} + (1/1500) C_K \quad (4)$$

Where C_{Ra} , C_{Th} and C_K are specific activities of ^{226}Ra , ^{232}Th and ^{40}K in Bq/kg, respectively (NEA 1979).

2.3.2. 4. Annual effective dose rates

To estimate the annual effective dose rates, the conversion coefficient from absorbed dose in air to effective dose (0.7 Sv/Gy) and outdoor occupancy factor (0.2) proposed by UNSCEAR were used (UNSCEAR 2000). The effective dose rate in unit of mSv/a was calculated by the following the following equation (5):

$$D_{\text{eff}} (\text{mSv/a}) = \text{Dose rate (nGy/h)} \times 8760 \text{ h} \times 0.2 \times 0.7 \text{ Sv/Gy} \times 10^{-6} \quad (5)$$

3. Results and Discussions

The activity concentrations of ^{226}Ra , ^{232}Th , and ^{40}K in the measured soil samples expressed in Bq/kg were ranged between 1.95 ± 0.08 to 13.07 ± 0.5 , 1.33 ± 0.11 to 10.04 ± 0.61 and 39.92 ± 3.43 to 193.71 ± 16.66 with activity weighted means 4.35 ± 0.028 , 3.3 ± 0.033 and 71.74 ± 7.21 respectively, table (1). The ^{40}K activity is higher than ^{232}Th and ^{226}Ra in all the samples. In order to test the correlations between ^{226}Ra and ^{232}Th , ^{226}Ra and ^{40}K and ^{232}Th and ^{40}K the obtained concentrations of naturally occurring radionuclides were plotted in the histogram figures (2). It is noted that a good correlation between ^{226}Ra and ^{232}Th was observed with a correlation coefficient of 0.7, whereas a poor correlations between ^{226}Ra with ^{40}K and ^{232}Th with ^{40}K were observed, with a correlation coefficients of 0.019 and -0.013 respectively. According to the recommended reference level of 30, 25 and 370 Bq/kg for ^{226}Ra , ^{232}Th and ^{40}K respectively, for the World average concentrations published by UNSCEAR, it is noted that the obtained results in most samples are lower than the recommended reference level (UNSCEAR 1988).

The activity concentrations of ^{226}Ra , ^{232}Th and ^{40}K in soil samples from the studied areas was compared with those from similar investigations in other countries and summary results were given in table (2). The comparison shows that the values of

soils under consideration are extremely low in accordance with others. The radium equivalent activity of each sample was estimated using the equation (4). The mean value of radium equivalent activities of all soil samples is 20.16Bq/kg. The mean value obtained for radium equivalent activity is too low in comparison with the limited value 370Bq/kg reported by Beretka and Mathew (1985).

The representative level index I_{yr} is less than unity for all samples under test which is in good

Table (1) Activity concentration in Bq/kg of ^{226}Ra , ^{232}Th and ^{40}K in soil samples with the external gamma dose rate (D_{eff}), Ra equivalent activity ($R_{\text{a,eq}}$), representative level index (I_r), and effective dose rate (mSv/a)

Sample code	Location	^{226}Ra (Bq/kg)	^{232}Th (Bq/kg)	^{40}K (Bq/kg)	D (nGy/h)	$R_{\text{a,eq}}$ (Bq/kg)	I_r (Bq/kg)	D_{eff} (mSv/a)
1	KaryAlqapha street	7.12±0.28	5.24±0.33	100.26±8.62	10.63	22.31	0.17	0.013
2	Kary	7.14±0.28	6.98±0.44	100.31±8.63	11.7	24.83	0.18	0.014
3	East Kary	6.75±0.26	4.67±0.29	86.16±7.41	9.53	20.05	0.15	0.012
4	ElsardyKary	4.15±0.17	4.26±0.26	39.92±3.43	6.15	13.31	0.1	0.007
5	ElwadaKary	9.83±0.38	6.85±0.43	91.61±7.88	12.5	26.67	0.2	0.015
6	North Kary	7.92±0.31	6.43±0.39	84.64±7.28	11.07	23.61	0.17	0.013
7	Alqapha street	4.39±0.18	2.12±0.13	77.71±6.68	6.55	13.4	0.1	0.008
8	Alqapha street A	3.94±0.15	3.79±0.23	99.81±8.59	8.27	17.03	0.13	0.01
9	Alqapha street B	7.22±0.28	4.91±0.3	97.35±8.37	10.36	21.72	0.16	0.013
10	South Kary	6.63±0.26	4.38±0.27	91.09±7.84	9.51	19.9	0.15	0.012
11	Ranya- Alqapha St. A	1.95±0.08	1.33±0.11	82.81±7.12	5.16	10.22	0.08	0.006
12	Ranya- Alqapha St. B	6.34±0.25	7.59±0.65	42.55±3.66	9.29	20.45	0.15	0.011
13	Ranya- Alqapha St. C	2.35±0.1	2.35±0.14	76.48±6.58	5.69	11.59	0.09	0.007
14	Ranya Street	11.04±0.43	9.66±0.59	66.89±5.75	13.72	29.98	0.21	0.017
15	MfrakKary	3.52±0.14	1.92±0.12	91.32±7.86	6.59	13.28	0.1	0.008
16	Alqapha street C	4.29±0.17	4.29±0.26	150.65±12.96	10.86	22.01	0.17	0.013
17	Alsnaya A	4.06±0.16	3.32±0.2	66.42±5.71	6.65	13.92	0.1	0.008
18	Alsnaya B	3.27±0.13	3.31±0.2	58.56±5.04	5.95	12.5	0.09	0.007
19	Alsnaya C	7.72±0.3	7.35±0.63	84.02±7.23	11.51	24.69	0.18	0.014
20	Alsnaya D	6.54±0.26	3.76±0.23	67.3±5.79	8.1	17.09	0.13	0.01
21	East Alhayrya A	8.16±0.35	5.09±0.31	94.07±8.09	10.77	22.67	0.17	0.013
22	East Alhayrya B	5.98±0.24	5.92±0.36	81.53±7.01	9.74	20.71	0.15	0.012
23	East Alhayrya C	10.53±0.41	8.7±0.53	111.43±9.59	14.76	31.52	0.23	0.018
24	East Alhayrya D	6.39±0.25	5.99±0.37	92.39±7.95	10.43	22.06	0.16	0.013
25	Middle Alhayrya	7.92±0.31	8.93±0.54	74±6.37	12.14	26.37	0.19	0.015
26	Alhayra E	5.9±0.23	4.68±0.29	89.76±7.72	9.3	19.49	0.15	0.011
27	South Alhayrya	6.99±0.27	5.99±0.36	88.5±7.61	10.54	22.35	0.17	0.013
28	Alhachrage farm A	3.1±0.12	2.01±0.12	65.86±5.67	5.39	11.03	0.08	0.007
29	Alhachrage farm B	7.22±0.28	5.39±0.33	73.1±6.29	9.64	20.53	0.15	0.012
30	Alhachrage C	5.83±0.23	3.67±0.24	53.05±4.56	7.12	15.15	0.11	0.009
31	Alhachrage D	4.14±0.16	2.5±0.16	60.77±5.23	5.95	12.38	0.09	0.007
32	Alhachrage street	3.89±0.18	1.9±0.14	193.71±16.66	11.02	21.5	0.17	0.013
33	Alhachrage E	5.46±0.22	6.32±0.39	93.68±8.06	10.24	21.69	0.16	0.012
34	Alhachrage F	3.21±0.14	5.05±0.31	91.97±7.91	8.37	17.51	0.13	0.01
35	South Alhachrage A	4.53±0.19	6.53±0.4	53.61±4.61	8.27	17.98	0.13	0.01
36	South Alhachrage B	3.31±0.14	2.3±0.14	69.82±6.01	5.83	11.97	0.09	0.007
37	Galawy A	7.82±0.34	6.63±0.41	72.16±6.21	10.63	22.84	0.17	0.013
38	Galawy B	8.83±0.34	5.64±0.34	88.93±7.65	11.19	23.72	0.17	0.014
39	Galawy C	9.41±0.37	9.28±0.57	87.01±7.48	13.58	29.36	0.21	0.016
40	Alkhldya A	9.29±0.36	7.01±0.44	73.72±6.34	11.6	24.98	0.18	0.014
41	Alkhldya B	13.07±0.5	8.97±0.55	77.42±6.66	14.69	31.85	0.23	0.018
42	Alkhldya C	6.85±0.27	6.83±0.42	77.16±6.64	10.51	22.54	0.17	0.013
43	Alkhldya D	9.76±0.39	10.04±0.61	79.16±6.81	13.88	30.19	0.22	0.017
44	Alkhldya E	3.6±0.14	2.33±0.14	79.66±6.85	6.39	13.05	0.1	0.008
45	Alkhldya F	7.3±0.37	4.84±0.3	92.12±7.92	10.14	21.3	0.16	0.012
46	Alsafala A	4.65±0.18	5.24±0.32	97.93±8.42	9.4	19.67	0.15	0.011
47	Alsafala B	5.34±0.21	3.78±0.23	127.21±10.94	10.05	20.52	0.16	0.012
48	Al gwyga A	4.61±0.19	4.73±0.29	58.47±5.03	7.42	15.86	0.12	0.009
49	Aldera	7.85±0.3	4.61±0.28	53.97±4.64	8.66	18.59	0.13	0.011
	Mean	4.35±0.028	3.3±0.033	71.74±7.21	9.54	20.16	0.149	0.0115

agreement with other studies (Taha, 2006; UNSCEAR 2000). At last, the calculated effective doses are small values which can be attributed to the content of radionuclides which is very low for all samples. The average annual dose from natural sources is 2.4 mSv which is a reference level representing the range 1~10 mSv/a and in extreme cases to 1 Sv or more (UNSCEAR 2000).

Table 2 Mean values of ^{226}Ra , ^{232}Th and ^{40}K for all soil samples under investigation beside other countries.

Country	Activity concentration (Bq/kg)			Reference
	^{226}Ra	^{232}Th	^{40}K	
Tourbh, Saudi Arabia	4.5	3.32	71	Present work
Canada (Saskatchewan)	19	8	480	Kiss., et al., 1988.
Upper Egypt	15.7	16.5	227.5	Abbady et al., 2009
Spain	39	41	578	Quindós., 1994
Brazil (Rio Grande do Norte)	29.2	47.8	704	Malanca.,et al., 1996
Turkey (Istanbul)	21	37	342	Karahan. and Bayulken, 2000
Denmark	17	19	460	UNSCEAR., 2000
Syrian	20	20	270	UNSCEAR., 2000
South India	35	29.8	117.5	Narayanq .et al., 2001
Jordan (Amman Aqaba Highway)	22-104	21-103	138-601	Al-Jundi ., et al., 2003
Mexico (Zacatecas and Guandalupe)	23	19	530	Mireles <i>et al.</i> , 2003
Cyprus	7.1	5	104.6	Tzortzis.,et al., 2004
Nigeria	16.2	24.4	34.8	Arogunjo., et al., 2004
Bangladesh (Southern districts)	42	81	833	Chowdhury et al. , 2006
Pakistan (Lahore)	25.8	49.2	561.6	Akhtar. et al. , 2005
Vietnam (South- east)	19.6	31	34.6	Huy., and Luyen, 2006
Egypt (Farm soil)	13.7	12.3	1233	Ahmed and El-Arabi 2005.
Nile island's soil	11.9	10.5	1636	

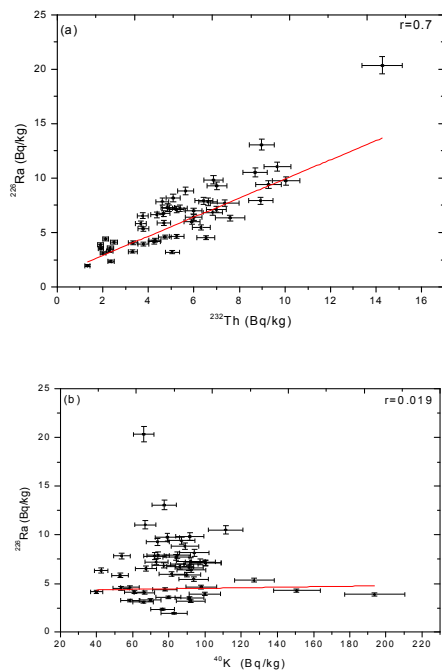

radium equivalent activity, external hazard index, internal hazard index and terrestrial absorbed dose rate were below the recommended limits.

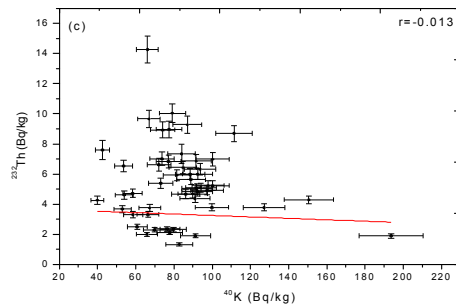

Figure (2) correlations between (a) ^{226}Ra with ^{232}Th , (b) ^{226}Ra with ^{40}K and (c) ^{232}Th with ^{40}K

4. Conclusion

Activity levels in the soil of Tourbh, Saudi Arabia have been measured. The mean activity of

^{226}Ra , ^{232}Th and ^{40}K were found to be 4.35 ± 0.028 , 3.3 ± 0.033 and $71.74\pm 7.21\text{Bq/kg}$, respectively. The mean radium equivalent activity Ra_{eq} , representative level index, and terrestrial absorbed dose rate for the area under investigation are 20.16 Bq/kg , 0.149 Bq/kg , and 9.54 nGy/h , respectively. The levels of

^{226}Ra , ^{232}Th , and ^{40}K in the soil of the Tourbh were comparatively less than the world average whereas

References

1. **Abbady, A., A.M. El-Arabi, Adel G.E. Abbady and S. Taha 2009.** Gamma-ray measurements of natural radioactivity In cultivated and reclaimed soil, Upper Egypt. <http://www.radioecology.info/Bergen2008/>
2. **Abbady, Adel G. E 2004.** Estimation of radiation hazard indices from sedimentary rocks in Upper Egypt. Applied Radiation and Isotopes 60, 111-114.
3. **Ahmed, N.K. and El- Arabi, A.M. 2005.** Natural radioactivity in farm soil and phosphate fertilizer and its environmental implication in Qena governorate, Upper Egypt. Journal of Environmental Radioactivity, 84, 51-64.
4. **Al-Jundi, J., Al-Bataina, B.A., Abu-Rukah, Y. and Shehadeh, H.M. 2003.** Natural radioactivity concentrations in soil samples along the Amman

- Aqaba Highway, Jordan. Radiation Measurements journal, 36, 555-560.
5. **Akhtar, N., Tufail, M., Ashraf, M. and Mohsin Iqbal, M. 2005.** Measurement of environmental radioactivity for estimation of radiation exposure from saline soil of Lahore, Pakistan. Radiation Measurements journal, 39, 11-14.
 6. **Arogunjo, A.M., Farai, I.P. and Fuwape, A. 2004.** Dose rate assessment of terrestrial gamma radiation in the Delta region of Nigeria. Radiation Protection Dosimetry Journal, 108, 73-77.
 7. **Beck, H.L. 1972.** The physics of environmental gamma radiation fields. Proceeding of the Second International Symposium on the natural radiation environment, Houston, Texas, 101-131.
 8. **Beretka J, Mathew P J. 1985** Health Phys, 1985, 48: 87-95.
 9. **Chowdhury, .I., Kamal, M., Alam, M.N., SalahaYeasmin and Mostafa, M. N. 2006.** Distribution of naturally occurring radionuclides in soils of the Southern Districts of Bangladesh. Radiation Protection Dosimetry Journal, 118, (1), 126-130.
 10. **El-Taher, A., 2010** Gamma spectroscopic analysis and associated radiation hazards of building materials used in Egypt. Journal of Radiation Protection Dosimetry 138(2): 158-165.
 11. **El-Taher, A., Madkour, H A 2010** Distribution and environmental impacts of metals and natural radionuclides in marine sediments in front of different wadies mouth along the Egyptian Red Sea coast. Appl.Radiat.Isot.60, 550-558.
 12. **Huy, N.Q. and Luyen, T.V. 2006.** Study on external exposure doses from terrestrial radioactivity in Southern Vietnam. Radiation Protection Dosimetry Journal, 118 (3), 331-336.
 13. **Karahan,G. and Bayulken, A. 2000.** Assessment of gamma dose rates around Istanbul. Journal of Environmental Radioactivity, 47, 213- 221.
 14. **Khan, K., Khan, H.M., Tufail, M., Ahmed, N. 1998.** Radiometric analysis ofhazara phosphate rock and fertilizers. Journal of Environmental Radioactivity, 38, 77-83.
 15. **Kiss, J.J., De Jong, E. and Bettany, J.R. 1988.** The distribution of natural radionuclides in native soils of Southern Saskatchewan, Canada. Journal of Environmental Quality, 17, 437-445.
 16. **Malanca, A., Gaidolif, L., Pessina, V. and Dallara, G. 1996.** Distribution of 226Ra, 232Th, and 40K in soils of Rio Grande do Norte (Brazil). Journal of environmental radioactivity, 30, 55-67.
 17. **Mireles,F., Dávila, J.I., Quirino, L.L., Lugo, J.F., Pinedo, J.L. and Ríos, C. 2003.** Natural soil gamma radioactivity levels and resultant
 18. **Narayanq, Y., Somashekarappa, H.M., Karunakara, N., Avadhani, D.N., Mahesh, H.M. and Siddappa, K. 2001.** Natural radioactivity in the soil samples of coastal Karnataka of South India. Health Physics, 80, 24-33.
 19. **NCRP, 1975** Background radiation in the USA recommendation of the National Council of Radiation and measurements Report No. 45.
 20. **NEA 1979** Report by NEA Group of Experts. 1979, OECD, Paris.
 21. **Parker, R.I., 1967.** Composition of earth's crust, chapter D.P.D. In: Fleischer, M. (Ed.), Data of Geo-Chemistry. US Geol. Survey Professional paper 440.D (US Government Printing Office, Washington).
 22. **Quindos 1994** Quindos L S., Fernandez PL, Soto J, *et al.* Health Phys, 1994, 66: 194-200.
 23. **Steinhaüslér, F., 1992.** The natural radiation environment: Future perspective. Radiation Protection Dosimetry Journal, 45(1/4), 19-23.
 24. **Taha S. 2006.** Natural radioactivity In cultivated and reclaimed soil from Qena, Uper Egypt. M.Sc. Thesis. South valley university , Egypt.
 25. **Tzortzis, M., Svoukis, E. and Tsertos, H. 2004.** A comprehensive study of natural gamma radioactivity levels and associated dose rates from surface soils in Cyprus. Radiation Protection Dosimetry Journal, 109, 217-224.
 26. **UNSCEAR 1988** United Nations Scientific Committee on the effects of Atomic Radiation: 1988. Sources, Effects and Risks of Ionizing Radiation, Report to the General Assembly, United Nations, New York.
 27. **UNSCEAR1993** United Nations Scientific Committee on the effects of Atomic Radiation. 1993. Sources, effects and risks of ionizing radiation. New York: United Nations.
 28. **UNSCEAR 2000** Report to General Assembly, with Scientific Annexes, Sources and Effects of Ionizing Radiation, New York: United Nations 2000.

Analytical Study of the Effect of Dividend Policy and Financing Policy on Market Value-Added in Tehran Stock Exchange

Karim RezvaniRaz¹, Ghasem Rekabdar²

¹. Department of Accounting, Khorramshahr branch, Islamic Azad University, Khorramshahr, Iran.

². Department of Mathematics, Abadan branch, Islamic Azad University, Abadan, Iran.

karim.rezvani@yahoo.com

Abstract: A corporate's value depends drastically on the maximizing the profit and the method of profit distribution as well as taking the proper approaches for financing. Distinguishing the policy of tension and traction dividend considering the investment opportunities and investment in suitable investing opportunities that needs traction policy of dividend, as well as the stockholders' satisfaction which takes the enforcement of tension policy of dividend in order to increase the Business Value-Added (BVA) is almost difficult and very sensitive. Moreover, it is more difficult to study and distinguish suitable approaches for consuming financing resources. We also should consider the way of distributing these resources as the dividend or consumption of these resources in using the profitable investment opportunities. This can be effective on fulfillment of increasing the efficiency of investment of investors and maximizing the stockholders' Wealth. Economic Value Added (EVA) can be used as an interior standard for the business operation. This standard result to creation of another external standard named Market Value Added (MVA). The firm's value can be evaluated through this MVA which is used in this study. Generally, detecting ways of financing (borrowings) and the way of cash distribution (dividend divided) and their affects ratio on maximization of a corporate value are among the complicated problems and subjects that studying and researching them would be very important for the analysts, investors, stock assessors, stock brokers, financial and credit institutions and other beneficial individuals and institutions. Therefore, according to this importance this article will study these variables and their relationship with the Market Value Added of the registered companies with Tehran Stock Exchange. The results of the tests show that in the companies with less opportunity and the big companies the Market Value Added is under the effect of financing policy and dividend policy, and there is a significant relationship between them.

[RezvaniRaz K, Rekkabdar G. **Analytical Study of the Effect of Dividend Policy and Financing Policy on Market Value-Added in Tehran Stock Exchange.** *Life Sci J* 2012;9(4):3578-3582] (ISSN:1097-8135). <http://www.lifesciencesite.com>. 529

Keywords: investment opportunities, Market Value Added (MVA), financing policy, dividend changes

1. Introduction

Capital structure and dividend policy play very important role in maximizing the shareholders' wealth and the company's value. The aim of determining the capital structure is to determine the financial resources mix in order to maximize wealth of shareholders. Optimal capital structure is the one which maximizes the corporate value. From the financial and capital structure point of view, because the capital cost is lower than debt cost (which is formed from Interest Expense Deductibility) makes the management to choose their financing with especial look at debt and to increase financial leverage of the company (Koch and Shenoy,1999). Therefore, financing decisions of financial managers and investors should lead to the maximization of the shareholders' wealth. Profitability is also the basic standard for performance measurement and the principal for the company's stock valuation that can help to the maximization of the shareholders wealth which leads to maximizing the firm's value as well. The dividend policy has a direct effect on the

shareholders expectation, available cash resources, way of financing, financial structure, and the consistency of the business entity. On the other hand, market value added is one of the most famous and suitable methods of testing the business performance which determines a value that is very close to market value added. Overall, familiarity with methods of dividend financing as well as awareness of the effects of these policies on the market value are very important and have been discussed in this research.

2. Stating problem

Aim of investment is to get profit and increase wealth. Maximizing the interest, way of financing and cash distribution are among the subjects the business management should study and consider as their most important duties. If a business entity has been unsuccessful in financing and programming of cash, insolvent and unable to distribute the dividend on time, then the firm's value significantly depends on its ability in low-cost financing and way of using it. Therefore, certainly,

the company would not be able to reach its aims and its life may not be certain. In the Free Cash Flow (FCF) theory it has been stated that the companies with partly high investment opportunities use their free resources in these kinds of opportunities in order to maximize the firm's value (Jaggi and Gul, 1999). This would result to maximization of the shareholders' wealth. It is believed that the company's policy in paying the dividend from the low-cost interior financing resource also can affect the company's value. Moreover, the consumption of these resources in using profitable investment opportunities will cause to deduction in paying the dividend (Jensen Theory 1986). Results of previous researches show that ways of financing resources, investment opportunities, and dividend policy are among the considerable information tools for the managers and investors with especial importance for maximizing the shareholders wealth, raising the motivation, and creating appropriate investment opportunities for the investors. It is important to recognize the expansion and contraction policies of dividend (Variable Dividend) as well as the subject of determining the financing resource (Debt Ratio) in order to distribute the dividend to the managers, shareholders, investors of the big companies and the companies with profitable investment opportunities (Gul and Kealy, 1999). The current research studies the relations between these two important variables i.e. financing and dividend policies along with the market value added of the accepted companies in Tehran Stock Exchange.

3. Literature Review

Graham Paul Barman has a research entitled 'An Evaluation of How Dividend Policies Impact on the Share Value of Selected Companies' for 42 south African countries for a period of 10 years. The decisions in this study were divided into three groups as follows: investment decisions, financing decisions and dividend decisions. Investment decisions determine kind and value of the used assets by the company. Financing decisions determine the company's capital structure and the necessary financing resources for the investment. Dividend decisions determine the distribution amount and procedure of cash dividends between the shareholders. The researcher found that the dividend's impact on a company's stock's current value is not only important for the management policy but also is important for planning and recognizing the investment market by the investors and economists. Therefore, the tests' results show that the dividend policy has a significant impact on the firm's value and the stock's value. In the year 2001, Vidhan k.Goyal, Kenneth Lehn, Stanko Racic

studied the relationship between the development opportunities and financing policies for 61 companies. The researchers, from the results of their research, mention that the changes in the level of the companies' debt are affected in the investment opportunity which there is an inverse relationship between these two variables. Hence, if there are high development opportunities, the level of debts will be low. On the contrary, if a corporate's debt increases the development opportunities will be low. Finally, they state that the issued debt maturity in the periods with low development opportunities is longer than the debt maturity in the period with high development opportunities.

4. Definition of operational variables

Market Value Added: this variable will be calculated according to the following relationship (Thenmozhi, 2000):

$$MVA = V - K$$

MVA is market value added, V is the market value of the firm, including the value of the firm's equity and debt, K is the capital invested in the firm. The invested capital is equivalent to shareholders' equity plus Long-term debt and Market Value defined by Market Price per Share multiply Number of Shares.

Debt ratio: in this research the financing policy is on the basis of external financing resource i.e. the debt ratio is defined that is measured according to the short-term and long-term liabilities. Investment opportunities: there is no consensus about investment opportunities' measurement and definition as well as providing a computational icon. According to research done abroad and the definition provided by Jaggi and Gul (1999), the following three criteria are used to calculate the investment opportunities. Note that market value of assets is derived from the total book value of assets and market value of shares.

$MBVA^1 = \text{market value of assets} \div \text{book value of assets.}$

$MBVE^2 = \text{market value of assets} \div \text{book value of shares.}$

$EP^3 = \text{earnings per share} \div \text{price per shares.}$

Dividend changes: it means the difference between the cash dividends per share of the current year and the previous year that is divided on price per share at the beginning of the financial year.

Dividend changes: by dividing the difference of cash dividends per share of the current year and cash dividend per share of the previous year

¹ - Market to Book Value of Asset

² - Market to Book Value of- Equity

³ - Earning / Price Ratio

by price per share at the beginning of the financial year so result is dividend changed. Firm size is measured based on the total assets it owns.

5. Research Hypothesis

- 1- In the firms with low development opportunities, there is a significant relationship between the dividend changes, the debt ratio and the firm value.
- 2- In the firms with high development opportunities, there is a significant relationship between dividend changes, debt ratio and the firm value.
- 3- In the big firms, there is a significant relationship between dividend changes, debt ratio and the firm value.
- 4- In the small firms, there is a significant relationship between dividend changes, debt ratio and the firm value.

6. Population and Sampling

The member companies of Tehran Stock Exchange that have retained their membership in the Stock Exchange during the considered period (i.e. from the begging of 2002 to the end of 2009) constitute the research community. The sampling is also done by omission Statistical method. The companies have been selected as sample that in the considered period of study have presented their financial statement to the Stock Exchange and their financial statements have been approved by the Iran Auditing Organization. Moreover, the disclosure of information along with the descriptive notes should be available and complete.

7. Methods of Statistical Analysis

This is an applied, descriptive and post-events research. To test the relationship between the variables of the research theories, the multiply linear regression has been used. Fisher's statistic (F) has been used for significance of the regression model (F) at 95% confidence level. The tested companies in the first and the second hypothesis are selected and classified based on the investment opportunities using multivariate statistical method of principal component and correlation matrix. In the third and the fourth hypothesis are selected and classified according to the size of the companies using the logarithmic method based on the median.

8. Hypotheses' Results

In testing the first and the second hypotheses using three defined ratios (EP, MBVE, and MBVA) as well as using Correlation Matrix and Eigen value have been calculated as a mutual standard for the investment opportunities. The values obtained from

the Correlation Matrix according to the principal components are presented in Table 1 and 2. The first component which has the highest value is selected as the mutual factor. The reason for selecting the basic component is that shows the most distribution or the proportion of variance of the population.

Table 1: basic components extracted for the investment opportunities

component	Especial amount		
	Total	Variance percentage	Cumulative variance percentage
First	1.418	47.279	47.279
Second	.998	33.264	80.544
Third	.584	19.456	100.00

Table 2: Coefficients of the basic components extracted

Ratio	MBVA	MBVE	EP
Principal Component	.835	.841	-.116

Based on the above results, the investment opportunities' Equation is obtained by using Coefficients of the first component as follows:

$$IOS = .835MBVA + .841MBVE - .116EP$$

The above linear equation's result is represented as a factor in the investment opportunities of the sample companies. After a calculating the mutual factor for all the companies, the descriptive statistics for the mutual factor IOS is calculated which is presented in table3.

Table 3: descriptive statistics for the mutual factor IOS and logarithm of assets (N=101)

Factor	Mean	standard deviation	Median
IOS	.0662	1.1547	-.2504
Log Asset	6.013	.671	5.8557

Using the median indicator, the corporate based on the investment opportunities factor are divided into two groups: a) corporate with low investment opportunities (as a sample for the first hypothesis), b) corporate with high investment opportunities (as a sample for the second hypothesis). In the third and the fourth hypotheses the corporate based on the logarithm of assets are divided into two groups of small corporate and big corporate. The median is used for the corporate segmentation. The companies higher than the median are considered as the big companies (as a sample for the third hypothesis) and the companies lower than the median are considered as the small companies (as a sample for the fourth hypothesis). The descriptive statistic is given in the table 3.

According to the test between the Dividend Policy, Debt Rate and the Market Value-Added in the low-growing companies, the Multiple Correlation is .878 and Corrected Coefficient of Determination is .761 I.e. almost %76 of Market Value-Added is presented by the dividend variable and debt rate variable. The regression equation has a significant positive slope and both coefficients are on the %5 Error level note be zero. According to standardized coefficient and as the debt rate's coefficient is higher, in this model, the debt rate comparing with the dividend policy is more important in order to test the Market Value-Added (table 4).

Table4: Multiple linear regression of the first hypothesis

Model	Unstandardized Coefficients		standardized coefficients	T	Sig.
	B	Std.Error	Beta		
(Constant)	0.634	0.064		9.94	.000
MTD	0.538	0.043	0.886	12.56	.000
DIV	0.000	0.000	0.156	2.21	.032
a. Dependent Variable: MEVM b. IOS=IOSMALL		R = 0.878 Adjusted R Square = 0.761			

In the second hypothesis in the companies with high investment opportunities, the results show that multiple correlation coefficients are 0.854 and the adjusted coefficient of determination is 0.726. According to Regression coefficients, level of statistical significance t and Zero coefficient both the variables on the %1 error level is rejected (table 5).

Table 5: Multiple linear regression of the second hypothesis

Model	Unstandardized Coefficients		standardized coefficients	T	Sig.
	B	Std.Error	Beta		
(Constant)	1.209	.132		9.16	.000
MTD	.696	.096	.595	7.21	.000
DIV	.000	.000	.415	5.03	.000
a. Dependent Variable: MEVM b. IOS= IOSlarge		R = 0.854 Adjusted R Square = 0.718			

The results of Multiple regression model from the third hypothesis show that The multiple correlation coefficient is 0.637 and the Adjusted coefficient of determination is 0.406. Moreover, according to the level of statistical significance t in the big companies there is a significant relationship between dividend policy and Market Value. Nevertheless, there is no significant relationship between the debt rate and the Market Value (table 6).

Table 6: Multiple linear regression of the third hypothesis

Model	Unstandardized Coefficients		standardized coefficients	T	Sig.
	B	Std.Error	Beta		
(Constant)	.976	.184		5.30	.000
MTD	.086	.250	.039	.34	.731
DIV	.000	.000	.640	5.65	.000
a. Dependent Variable :MEVM b.size=large		R=.637 Adjusted R Square =.406			

The results from the fourth hypothesis show that the multiple correlation coefficients are 0.884 and the adjusted coefficient of determination is 0.773. Zero variable coefficients show that in the small companies, on the %1 error level, there is a significant relationship between the debt rate, dividend policy and company value. Furthermore, the company's value is affected by the both variables.

Table 7: Multiple linear regression of the fourth hypothesis

Model	Unstandardized Coefficients		standardized coefficients	T	Sig.
	B	Std.Error	Beta		
(Constant)	.919	.123		7.50	.000
MTD	.527	.072	.532	7.36	.000
DIV	.001	.000	.540	7.46	.000
a. Dependent Variable: MEVM b. Size=small		R = .884 Adjusted R Square =.773			

8. Discussions

According to the theory of free cash flows in firms with low investment opportunities, it is expected to have free cash flows. Because, these companies don't have opportunities for investing surplus cash or they have little cash and the cash they have kept in higher levels. From other hand, the trusters and the investor are interested to invest in companies which have high free cash flow. It is also expected the companies with high free cash have high debt too. The shareholders expect that such companies distribute more shares. Therefore, in companies with low investment opportunities due to lack or shortage of profitable opportunities and also to prevent the stylistic management of cash as well as the retaining the firm's value, distributing the debts and dividend, are the best ways capable of increasing the market value added of the companies. On the contrary, in companies with high investment opportunities, the management tries by selecting and investment in opportunities with net positive present value, to maximize the firm's value. Hence, in companies which have specific free cash consumptions and it is expected that this cash to be spent as the internal financing resources which are less costing than the external financing resources to be invested on the profitable opportunities. Therefore, in such companies are less affected by the

debt ratio and the dividend policy. In the big companies the company's value is also affected by the dividend variable but there is no significant relationship between the debt rate and the company's value. Moreover, in the small companies because of their low flexibility in financing both the dividend and the financing affect on the Market Value Added. Generally, the results from this research are the same as the results from the research has done by Flex and Joan in 2008.

This research is done without considering the mutual effects of debt ratio and the dividend policy on the value added. Future researches could be done with considering the effects of debt ratio and the dividend policy on each other and the also their relationship with market value added.

- It is recommended to investigate the effect of capital structure on the market value added of the companies for the future researches.

- It is recommended to study the same topic but on the specific industries.

- It is recommended to study a subject with a title like 'market value added and the stock price behavior'

-It is recommended the relationship between the free cash flows, investment opportunities and financing policy to be studied.

- It is recommended to study the impact of increase of dividend from the free cash resource on the capital structure.

Acknowledgment

This article is resulted from a research project which financed by Islamic Azad University Khorramshahr branch.

Corresponding Author:

Karim RezvaniRaz
Department of Accounting
Islamic Azad University, Khorramshahr branch
E-mail: karim.rezvani@yahoo.com

References:

1. Berry L E. Management Accounting Demystified. McGraw-hill, 2006.
2. Gul F A, Kealy B T. investment opportunity set and corporate debt and dividend policies of Korean companies. Review of quantitative finance and accounting, 1999, 401-415.
3. Utami S R, Inanga E L. Agency Costs of Free Cash Flow, Dividend Policy, And Leverage of Firms In Indonesia. European Journal of Economics, Finance And Administrative Sciences, 33,2011.

4. Koch P D, Shenoy C. The Information Content Of Dividend And Capital Structure Policies. Financial Management, 28, 4, 1999, 16-35.
5. Thenmozhi M. Market Value Added And Share Price Behavior" Delhi Business Review, 1,2000.
6. Kallapur S, Trombley M A. The association between investment opportunity set proxies and realized growth. Journal of business finance and accounting, 1999.
7. Jaggy B, Gul F A. Analysis of joint effects of Review of investment opportunity set, Free cash flow and size on corporate debt policy. quantitative finance and accounting, 1999.
8. Adam T, Goyal V. The investment opportunity set its proxy variables: Theory and Evidence. Hong Kong university of science and technology, 2000.

11/20/2012

Association between job stress and job satisfaction among Iranian Gynecologists

Morteza Salimi¹, Minoor Rajai², Hamid Haghighi³, Masoud Shareghi¹, Mojtaba Salimi⁴, Sakineh Fallahi⁵, Seyed Reza Mirsoleymani¹, Ali Akbar Hesam⁶, Soghra Fallahi⁷, Fatemeh Zare⁸, Sakineh Dadipour⁸

- ¹. Student Research Committee, Department of Research and Technology, Hormozgan University of Medical Sciences, Bandar-e-Abbas, Iran
- ². Associate Professor, Research Center for Reproductive Health & Infertility, Hormozgan University of Medical Sciences, Bandar-e-Abbas, Iran
- ³. M.Sc in Family Counseling, Counseling & Psychological Service Center, Hormozgan Education Department, Bandar-e-Abbas, Iran
- ⁴. Student of MBA, Department of Management, Hormozgan University of Technology
- ⁵. M.Sc in Nursing, Research Center for Reproductive Health & Infertility, Department of Research and Technology, Hormozgan University of Medical Sciences, Bandar-e-Abbas, Iran
- ⁶. M.Sc Student of Clinical Psychology, Research Center for Reproductive Health & Infertility, Department of Research and Technology, Hormozgan University of Medical Sciences, Bandar-e-Abbas, Iran
- ⁷. M.Sc in Physiology, Research Center for Reproductive Health & Infertility, Department of Research and Technology, Hormozgan University of Medical Sciences, Bandar-e-Abbas, Iran
- ⁸. M.Sc Student of Health Education, Research Center for Reproductive Health & Infertility, Department of Research and Technology, Hormozgan University of Medical Sciences, Bandar-e-Abbas, Iran
pooya4022@yahoo.com

Abstract: The positive outcomes of job satisfaction (job satisfaction) lead to increasing the productivity (promotion on ability) ensuring the physical and mental health, and increasing the speed of Training New job skills. This study evaluated the effects of occupational stress on job satisfaction. The study sample consisted of gynecologists. 130 subjects were selected by sampling method. The instruments include a questionnaire of 35 questions on hospital stress and 45 questions of job satisfaction. Results indicated that the five components of job stress, can significantly predict job satisfaction which explains in total, 79% of the variance in job satisfaction. the results of Friedman test showed that the components of job satisfaction (nature of the work itself) has the first rank, salary and benefits (compensations and benefits) has the second rank and job promotion (promotion opportunities) has the third rank. Results also showed that specialists under 40 years of age have higher job satisfaction than 41 to 50 years old and 51 to 60 years old groups. It seems that job stress is one of the negative factors on job satisfaction among gynecologists. [Morteza Salimi, Minoor Rajai, Hamid Haghighi, Masoud Shareghi, Mojtaba Salimi, Sakineh Fallahi, Seyed Reza Mirsoleymani, Ali Akbar Hesam, Soghra Fallahi, Fatemeh Zare, Sakineh Dadipour. **Association between job stress and job satisfaction among Iranian Gynecologists.** *Life Sci J* 2012;9(4):3583-3586] (ISSN:1097-8135). <http://www.lifesciencesite.com>. 530

Keywords: Job stress, Job satisfaction, gynecologist

1. Introduction

Job satisfaction is one of the necessary and valuable components in the promotion of health and life satisfaction. Job satisfaction in the field of medical and hospital services has always been of interest to researchers, because it ensures the personnel working in the field of public health. The mental and physical health damage to manpower expert with the cost savings and convenience is not justified by any reason (1).

Job satisfaction is a general attitude toward one's job and so someone who has a high level of job satisfaction, has a positive attitude towards his/her job (2). Some researchers argue that job satisfaction refers to the degree of positive feelings and attitudes that people have toward their jobs. This means that when someone expresses a high job satisfaction, then

it can be concluded that she/he really likes her/his job, has a good feeling toward his/her job and possibly does his/her job correctly (3). Many factors have been associated with job satisfaction one of these is job stress. Job stress is the accumulation of stress – making factors and job-related situations. In other words this is a stress that a certain person faces with. Job stress occurs in many occupational groups. One of these is the health field. Studies have shown that occupational stress is highly prevalent among medical staff, including doctors, and can reduce job satisfaction (4-8).

Among these, gynecologists face lots of job stress due to long working hours, high stress environment, fear of malpractice and the pursuit of justice and sensitivity among medical staff that can affect their job satisfaction and professional

performance (9, 10). This study examines the relationship between job stress and job satisfaction among female professionals. Although many studies have been done in the field of occupational stress among medical staff, but there is little evidence on the relationship between job stress and job satisfaction. Therefore, in this study we investigated the relationship between job stress and job satisfaction among gynecologists to provide grounds for further actions to improve the health system.

2. Material and Methods

This research study was descriptive - correlation, regression analysis. The study sample consisted of all gynecologists. 130 doctors were selected as sample in the study. Those doctors who participated in scientific seminars were chosen for the study. All participants in the study were female.

The instruments included a demographic questionnaire (including age, marital status, academic rank, location and service history), Hospital job stress questionnaire with 35 questions and job satisfaction questionnaires. The questionnaire was conducted in Iran in 2008. It's Reliability and validity was done by retest and Cronbach's alpha was 0.84 (11, 12). Measuring instrument as well as reliability and validity was done in 2009 and Cronbach's alpha was 0.89. SPSS software version 19 and descriptive tests were used to analyze data.

3. Results

Descriptive findings showed that 76.2% of the sample is comprised of physicians who worked in major cities and 23.8 percent of them worked in small towns. Also, 23.8 percent of participants were Assistant Professors and 13.8 percent, were Associates and 1.5 percent were professors and 60.8 percent were Non-faculty physicians.

Analysis of the relationship between the components of job stress with the components of job satisfaction using regression test showed that the relationship between job satisfaction and job Ergonomic is equal to 0.76 and the coefficient of determination or $0.59=R^2$. Thus, the five elements of ergonomic factors, role ambiguity, shift, chemical factors and the low load are variables that are

considered as significant predictors of job satisfaction. These five factors explain 79 percent of job satisfaction variables and are scales which show one of the aspects of stress.

To analyze the characteristics of job satisfaction Friedman test was used. The results, from the perspective of gynecologists showed that job feature has the first rank salary and benefits, has the second rank the working conditions has the third rank and job promotion has the lowest rank. Chi-square value was also 12/99 with 3 degrees of freedom at an alpha level of 0/01 was significant. The ANOVA test was used to examine age differences in job satisfaction among gynecologists.

Table 1. Values of multiple correlation coefficients between the components of job stress and job satisfaction

	Variables	R	R ²
Step 1	Ergonomic factors	0.76	0.59
Step 2	Ergonomic factors	0.84	0.71
	Ambiguity		
Step 3	Ergonomic factors	0.87	0.77
	Ambiguity		
	Shifts		
Step 4	Ergonomic factors	0.88	0.78
	Ambiguity		
	Shifts		
	Chemical factors		
Step 5	Ergonomic factors	0.89	0.79
	Ambiguity		
	Shifts		
	Chemical factors		
	Low load		

The results showed that there is a significant difference with a value of alpha 0.01 with amount of $F=9.61$ among gynecologists in the age range in the variable of Job satisfaction. Scheffe's test was used to accurately track the differences between age groups. Gynecologists under 40 years old have a higher job satisfaction than gynecologists of 41 to 50 years old or 51 to 60 years old.

Table 2. Results of ANOVA tests to examine differences in job satisfaction according to age groups

The source of change	SS	df	MS	F	P
Inter- group differences	14.9	3	4.69	9.61	0.01
Intra-group differences	61.55	126	0.48		
Total	75.64	129			

4. Discussions

This study examined the relationship between job stress and job satisfaction among gynecologists. Regression analysis of the relationship between job stress and job satisfaction components showed that totally five components, ergonomic factors, role ambiguity, shifts, and chemical factors and low load explain 0.79% of the criterion variables of job satisfaction. These components are considered as significant predictors of job satisfaction. Ergonomic factors refer to the suitability of work environment, duties and methods of working with staff. And it covers factors such as workers' abilities According to the type of work and energy, physical body aspects (anthropometry), and psychological studies from the perspective of the relationship between people. Ambiguity was also one of the factors that lead to job stress. Role ambiguity refers to a situation in which some of the information necessary to perform the job are inadequate or misleading, thus the person does not know what others are expecting him to do. Low load of role is a condition in which a person's skills are not fully utilized (13). The stress from the situation is called the low load of role. Anything that is performed certainly outside the normal working hours per day (7:00 am to 18:00 pm) is called shift. Shift refers to issues such as night shift or day shift or fixed period or changes in shifts weekly. Shifts are also factors which cause job stress.

Chemical factors such as chemical matters used in working environments are the potential causes of stress (14). The findings of this study adjust with findings of Ghafooriyan, Ghasemi, Ebrahimi, Bartam, Abedi (3, 4, and 15). The study of importance order of job satisfaction components among gynecologists from the perspective of gynecologists showed that job characteristic has the first rank, salary and benefit has the second rank, working condition has the third rank and job promotion has the lowest rank. This finding can be explained by the theory of Ginzberg et al. Keynes's theory refers to both internal and external factors of job satisfaction. An internal satisfaction that comes from a job Include issues such as working and observing development and abilities of the person. The external satisfaction includes work conditions, wages and bonuses, types and relationships between partners. According to Kinzberg and his colleagues, the general satisfaction is the result of the interaction between internal satisfaction and external satisfaction and the results of the present study also confirm the same issue (16).

The results showed that job satisfaction decreases with age and younger professionals (under 40 years) reported higher job satisfaction than older

professionals (in the range of 41 to 50 years 51 to 60 years) (3). These findings do not confirm the findings of other research (17, 18, and 19). Because Ebadi and colleagues found that older practitioners are more satisfied with their jobs due to better job opportunities and higher relative prosperity (5, 9). However, in this study, job satisfaction decreases with age. On the other hand we can say that these findings are consistent with the findings of Roth et al and Mojamed et al. In their study, they showed that age is one of the factors affecting job satisfaction.

Since job stress components are predictors (ergonomic factors, ambiguity shifts, chemical factors and low load), it is essential to pay attention to these issues in order to improve the job satisfaction of gynecologists. On the other hand, the increasing support for gynecologists and providing counseling and psychological services in the field can be a useful help for reducing job stress.

Corresponding Author:

Sakineh Dadipour
Research Center for Reproductive Health & Infertility, Department of Research and Technology, Hormozgan University of Medical Sciences, Bandar-e-Abbas, Iran
E-mail: pooya4022@yahoo.com
Tel & Fax: +98.7613337104

References

1. Habib, Sepideh Shirazi, Mohammad Ali. (1382). job satisfaction and mental health in a general hospital. *Journal of Psychiatric and Mental Clinical Immunology*, Volume 8, Number 4, pp. 73-64
2. Robbins SP. *Essentials of organizational behavior*: Prentice Hall; 2005.
3. Abedi, Kamal Uddin, Zare, Mohsen Barkhordari, Abolfazl and Helvani , Gholam Hussein (1388) Job stress and job dissatisfaction and its relationship with individual factors and events in one of the industries in iran , *Journal of Medical Sciences , Jahrom*, Volume VII, No. 2, pp. 20-10.
4. Bartram T, Joiner TA, Stanton P. Factors affecting the job stress and job satisfaction of Australian nurses: implications for recruitment and retention. *Contemporary Nurse*. 2004;17(3):293-304
5. Monjamed Zahra , Ghorbani Tahereh, Mostofian Farnaz, Oveysi poor Roxana, Nokhostbandi Soghra, Mahmoodi Mahmood (1383). Job satisfaction of nursing groups in health centers and training nationwide. *Life Magazine*, Year 10, No. 23, pp. 48-39.
6. Ebadi Mehdi, Montazeri Ali, Azin Seyyed Ali, Shahid zadeh Ali, Harirchi Amir Mahmood,

- Baradaran Moghadam Hamid Reza, Yordkhani Fatemeh (1384). Job satisfaction of physicians with offices in Tehran, Payesh magazine, , No. 3, pp. 195-189.
7. Ghazali SSA, Shah IA, Zaidi SAA, Tahir M. Job satisfaction among doctors working at teaching hospital of Bahawalpur, Pakistan. J Ayub Med Coll Abbottabad. 2007;19(3)
 8. Dasgupta H, Kumar S. Role stress among doctors working in a government hospital in Shimla. European Journal of Social Sciences. 2009;9(3):356-70
 9. Roth SF, Heo G, Varnhagen C, Glover KE, Major PW. Occupational stress among Canadian orthodontists. The Angle Orthodontist. 2003;73(1):43-50
 10. Caplan RP. Stress, anxiety, and depression in hospital consultants, general practitioners, and senior health service managers. Bmj. 1994;309(6964):1261-3
 11. Smith PC. The measurement of satisfaction in work and retirement: A strategy for the study of attitudes. 1969
 12. Maraee Mohammad, (1379) Study of job satisfaction of workers in the cultural sector of Isfahan, Project of Management and Planning Organization.
 13. Khanifar Hussein (1387) job stress and professional environments (causes, theories, effects). Strategy Magazine, Year One, Issue 2, pp. 38-1.
 14. Badaghi Mazaher, (1389) Healthcare Job Stress Questionnaire. Tehran: Azmoon yar Pooya institute, No. 11.
 15. Ghafooriyan Homa, Ghasemi Iraj and Ebrahimi Muhammad, (1390) Evaluation of the impact of job stress on job satisfaction and school administrators. New Journal of Educational Sciences, year VI, No. 4, pp. 48-33.
 16. Ginzberg E, Ginsburg S, Axelrad S, Herma J. Occupational choice. New York. 1951
 17. Bahadori M., Toufighi S., Ameriun A., Ravangard R., Abbasi A., Jalalian M. Evaluation of Input Indicators Related to Human Resource Productivity in a Military Hospital in Iran. HealthMed. 2010; 4(2):323-327.
 18. Siddiqui A., Danial A. H., Muhammad F. H., Jalalian M. Perceived Issues and Challenges to Professional Development of Faculty Members in Tertiary Academic Institutes of Punjab, Pakistan. Journal of American Science. 2011;7(12):533-538. Available online at: http://www.jofamericanscience.org/journals/am-sci/am0712/069_7407am0712_533_538.pdf
 19. Danial A. H., et. al. A Review of Teachers' Professional Development Initiatives and Associated Issues and Challenges in Higher Education Institutes of Pakistan. Journal of American Science. 2012; 8(1):54-60. Available online at: http://www.jofamericanscience.org/journals/am-sci/am0801/008_7762am0801_54_60.pdf

9/9/2012

The proliferative and apoptotic effects of garlicin on mouse myeloma cell line SP2/0

Hui Wang^{1,2}, Xiangchen Li¹, Guangbin Wang¹, Xiaohong He¹, Weijun Guan¹, Yuehui Ma¹

¹ Institute of Animal Science, Chinese Academy of Agricultural Sciences, Beijing 100193, China

² College of Wildlife Resources, Northeast Forestry University, Harbin 150040, China

Hui Wang and Xiangchen Li contributed equally to this work

Yuehui_Ma@hotmail.com; weijunguan301@gmail.com.

Abstract: In order to investigate the proliferative and apoptotic effects of garlicin on mouse myeloma cell line SP2/0, and to explore the mechanisms of garlicin induced apoptosis, mouse myeloma cell line SP2/0 was used as research material. morphological events and calcium dynamics were observed with phase contrast and confocal microscopy, mitochondrial transmembrane potential, cell cycle progression and apoptotic rates were detected using flow cytometry, and TUNEL staining and agarose gel electrophoresis were performed upon exposure to the drug. Garlicin exerts a strong inhibitory effect on SP2/0 cell line, which is dosage and duration dependent. There occurred typical apoptotic morphological alterations at 48h upon exposure. Calcium dynamics were disturbed, cell cycle was arrested at G0/G1 checkpoint, and the ratio of cells in G0/G1 phase was gradually increased while the proportion in S phase was reduced with elevated concentration. Mitochondrial transmembrane potential dropped. The viable-apoptotic and non-viable apoptotic rates were both dose-dependent. Agarose gel electrophoresis revealed that "DNA ladders", a symptom of DNA fragmentation, had taken place. Garlicin could effectively inhibit the proliferation of SP2/0 cell line, influence cell cycle progression and induce apoptosis.

[Wang H, Li XC, Wang GB. **The proliferative and apoptotic effects of garlicin on mouse myeloma cell line SP2/0.** *Life Sci J* 2012;9(4):3587-3594] (ISSN:1097-8135). <http://www.lifesciencesite.com>. 531

Keywords: Garlicin; Mouse myeloma cell line SP2/0; Apoptosis

1. Introduction

Garlicin, or allitrid, whose chemical name is diallyl disulfide, is a sulfocompound extracted from garlic bulb. It has a unique pharmacological effect against infection, DNA damage, arteriosclerosis, plays a protective role in cell viability improvement, antioxidation and detoxification (Lv et al., 2006), and functions as a strong inhibitor of leukemia, hepatoma, oophoroma and gastric carcinoma. Evidence is accumulating that correlates daily intake of garlicin with defense against carcinogenesis (especially cancers in gastrointestinal tract and oral cavity). Garlicin can block the synthesis of carcinogens, inhibit their activation and reduce the risks of teratogenesis, as a result of which extensive attention has been attracted in regard to its therapeutic prospect (Velmurugan et al., 2003; Leist et al., 1996).

Statistics have revealed that the incidence of myeloma, a common type of carcinoma in mice, is increasing year by year, seriously threatening the robustness, and even survival, of rodents. Despite the fact that chemotherapeutic drugs have some effects in the prevention and treatment of myeloma, the concomitant side effects and development of chemoresistance have made them far from being applicable in clinical trials. A new concept is to extract active ingredient from medicinal herb for administration. In this paper, mouse myeloma cell line SP2/0 was used as the research object, to investigate the antitumor effects of garlicin and to

unravel the underlying mechanism to restore the apoptotic sensitivity, therefore providing important insights in therapeutic strategies.

2. Material and Methods

2.1 Drug solution preparation

Garlicin (National institute for the control of pharmaceutical and biological products) of 0.5 ml, was dissolved with DMSO, filtered for sterilization, adjusted to a concentration of 1.5 mg/ml, subpackaged, and then preserved at -20°C in the refrigerator. It should be diluted to the required concentration with DMEM medium prior to treatment, and the final concentration of DMSO should be no more than 0.1% in the experiments.

2.2 Cell culture

Mouse myeloma cell line SP2/0 was purchased from Shanghai cell bank, Chinese Academy of Sciences, The cells were cultured using DMEM medium (Gibico, USA) that contains 10% fetal calf serum in a humidified atmosphere at 37°C, 5% CO₂ (Freshney, 2000; Guan et al., 2005; Zhou et al., 2004). The culture medium was refreshed when its color become yellow; and the cells were passaged when 70%-80% confluent (The cells are semi-adherent and semi-suspended without the need of trypsinization when subcultured).

2.3 Growth kinetics

Following the method of Gu et al (2006) and Kong et al (2007), the SP2/0 cells were plated onto 24-well microplates at the concentration of 2.5×10^4 cells/well and cultured up to 7 days. Cells were harvested from three wells per day and counted. The mean values were used to plot a growth curve and to calculate the population doubling time (PDT).

2.4 Morphological observation

2.4.1 inverted phase contrast microscope observation

The cells were plated on each well of 6-well microplates at the concentration of 4×10^5 cells/well, and treated with garlicin 24 h later. They were observed under a phase-contrast microscope at 48 h upon treatment.

2.4.2 confocal microscopy observation

To investigate their chromatinic alterations, the cells from a single well were harvested, pelleted, resuspended and stained with 6 μ l AO and EB solution (both 2 mg/ml in ethanol). Incubated at room temperature in the dark for 5 min and then observed using confocal microscopy (Nikon TE-2000-E, Japan) immediately.

2.5 Annexin V-FITC/PI double staining

Cells upon garlicin treatment were collected, and then spun at 1200 rpm, 4°C for 10min. With supernatant discarded, they were washed with precooled PBS twice, 10^6 cells of which were then resuspended with 500 μ l Binding Buffer and stained with 5 μ l AnnexinV-FITC (20mg/L) and 5 μ l PI (20mg/L) in the dark for 15min at room temperature. The samples were analysed with FCM (BD FACSCalibur, USA) within 1 h.

2.6 TUNEL staining

TUNEL microslides were prepared using In Situ Cell Death Detection Kit (Roche, UK). Apoptotic SP2/0 cells emitted green fluorescence. Count 1000 cells from each of 10 large visual fields randomly selected for subsequent calculation. The positive rates were regarded as apoptosis rate.

2.7 Agarose gel electrophoresis

SP2/0 cells treated for 48 h were harvested, washed twice with PBS and then mixed with lysis buffer. After proteinase K added in, the cells were digested for about 12 h at 56°C. The products were extracted using phenol-chloroform, deposited with cold ethanol, and dissolved in TE buffer. DNA samples were detected by 20 g/L agarose gel electrophoresis at 150 v for 40min. The results were photographed and observed for the formation of DNA ladders.

2.8 Calcium dynamics

Cell suspension was plated into 6-well microplates at the concentration of 4×10^5 cells/well, cultured for 24 h, and then treated with garlicin. The cells were harvested, washed twice with PBS and stained with 200 μ l Fluo-3/AM solution (15 μ mol/L in 30 mmol/L HEPES) for 30 min. Then, they were washed thrice with PBS and observed under a confocal microscope (Nikon TE-2000-E, Japan) immediately.

2.9 Cell cycle analysis

Cells upon garlicin treatment were collected, and then spun at 1200 rpm, 4°C for 10min. With supernatant discarded, they were washed with precooled PBS twice, resuspended in ice-cold 70% ethanol (v/v), and kept at 4°C overnight. Pelleted and washed twice with PBS, the samples were stained with PI solution (PI 0.05 mg/ml, RNase 0.02 mg/ml, NaCl 0.585 g/ml, sodium citrate 1 mg/ml, pH 7.2-7.6) at 4°C for 30min (Zhang et al., 2007). The cells were filtered using 400-mesh sieve, and then detected with FCM (BD FACSCalibur, USA) immediately.

2.10 Detection of mitochondrial transmembrane potential

Cells upon garlicin treatment were collected, and then spun at 1200 rpm, 4°C for 10min. With supernatant discarded, they were washed with prewarmed PBS twice. The cells were stained with Rhodamine 123 (5 μ g/ml in PBS, pH 7.4) and incubated at 37 °C in the dark for 1 h. Washed thrice with prewarmed PBS (Zhang et al., 2006), they were resuspended and analysed using FCM (BD FACSCalibur, USA) immediately.

3 Results

3.1 Growth kinetics

The cells were in the latent period in the first to second days, then entered into the logarithmic growth phase in the second to fourth days, and presented a typical S-shaped growth curve. The concentration reached its peak in the fourth day; Cell entered the plateau phase in the fifth day, followed by an overall degeneration thenceforth (Figure 1).

3.2 Morphological observation

3.2.1 inverted phase contrast microscope observation

Cells upon garlicin treatment for 48 h were observed, and the results suggested that typical apoptosis morphological changes, for example, cell shrinkage, membrane blebbing, cytoplasmic condensation, the generation of apoptotic bodies and so on (Figure 2). The treatment produced a dose-dependent increase in apoptotic rate.

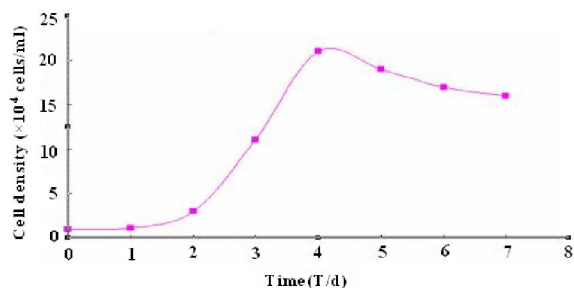

Figure 1. The growth curve of SP2/0 cell line

3.2.2 confocal microscopy observation

Apoptotic Necrotic cells gradually increased upon treated with by garlicin treatment at the concentrations of $2\mu\text{g/ml}$, $4\mu\text{g/ml}$ and $6\mu\text{g/ml}$ with elevated drug dose. In a sharp contrast, most of the population switch to viable-apoptotic state treated with $8\mu\text{g/ml}$, $10\mu\text{g/ml}$ garlicin, from which it could be inferred that apoptotic effects of $8\mu\text{g/ml}$ and $10\mu\text{g/ml}$ garlicin were optimal on SP2/0 cells (Figure 3).

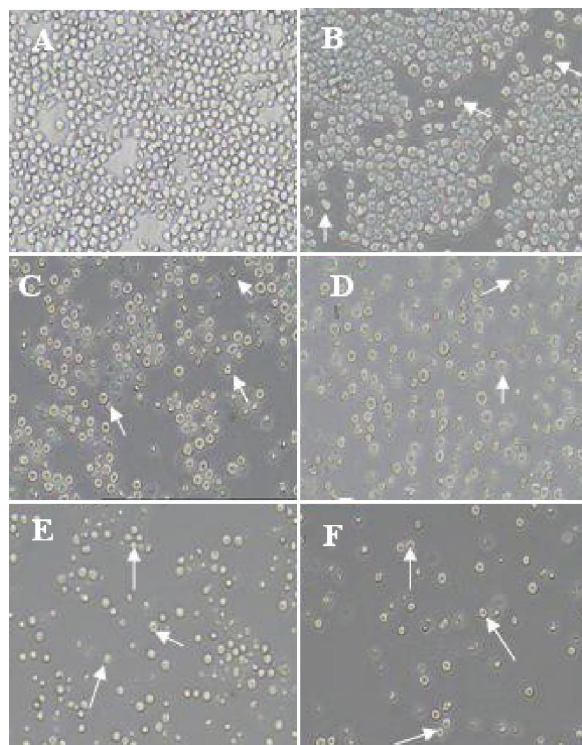

Figure 2. Morphological alterations of SP2/0 cell with garlicin treatment for 48 h ($10\times$) (Arrows point to apoptotic cells) A. control; B. $2\mu\text{g/ml}$; C. $4\mu\text{g/ml}$; D. $6\mu\text{g/ml}$; E. $8\mu\text{g/ml}$; F. $10\mu\text{g/ml}$.

Normal cells possess brown fluorescent cytoplasm and slightly green nuclei. Yellow

fluorescent cells with condensed nuclei were viable-apoptotic ones, and those with only red fluorescence or and condensed nuclei were in non-viable-apoptotic phase. In order to investigate the apoptotic effects with protracted time, SP2/0 cells treated with garlicin were at 60 h were stained with EB and observed with confocal microscopy. There were a large number of apoptotic cells upon the treatment with $2\mu\text{g/ml}$ garlicin, whereas in other groups mass necrosis had taken place, giving rise to the speculation that garlicin could lead the treated cells to a flexible cell death, in other words, to apoptosis at lower concentration and to necrosis at higher concentration.

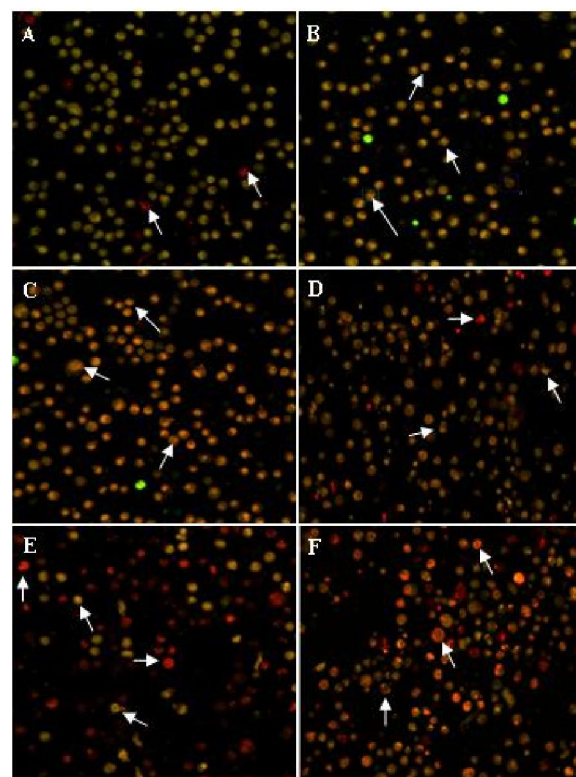

Figure 3. Morphological alterations of SP2/0 cell with garlicin treatment for 48 h ($40\times$) (Arrows point to apoptotic cells). A. control; B. $2\mu\text{g/ml}$; C. $4\mu\text{g/ml}$; D. $6\mu\text{g/ml}$; E. $8\mu\text{g/ml}$; F. $10\mu\text{g/ml}$.

3.3 AnnexinV-FITC/PI double staining

The apoptotic rate increased with elevated concentration upon garlicin treatment at 48 h, indicating that concentrations of $4\mu\text{g/ml}$, $6\mu\text{g/ml}$, $8\mu\text{g/ml}$ were already adequate for apoptosis inducing of SP2/0 cells. To the contrary of those of control, viable-apoptotic and necrotic rates in treated samples were considerably high, therefore supporting the concept that garlicin was a potent antitumor drug by means of apoptosis (Figure 4 and Table 1).

3.4 TUNEL staining

Positive cells occurred in all the samples (Figure 5), in particular evident in the treated groups with 6 $\mu\text{g/ml}$, 8 $\mu\text{g/ml}$ and 10 $\mu\text{g/ml}$ garlicin, which concentrations seems to have satisfactory apoptotic effects on SP2/0 cells. Positive cells were those with green fluorescences.

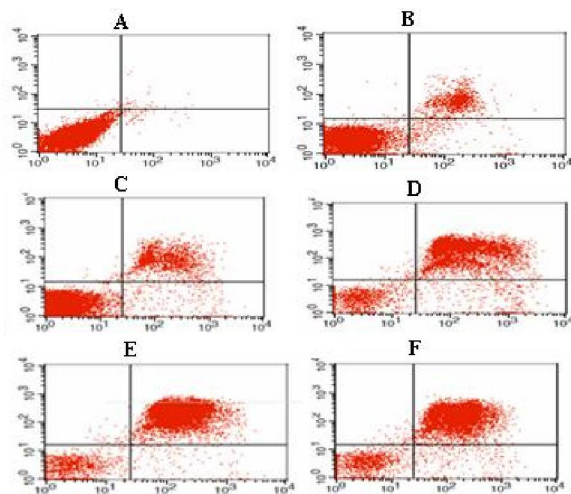

Figure 4. Apoptosis rate of SP2/0 cell with garlicin treatment for 48 h. A. control; B. 2 $\mu\text{g/ml}$; C. 4 $\mu\text{g/ml}$; D. 6 $\mu\text{g/ml}$; E. 8 $\mu\text{g/ml}$; F. 10 $\mu\text{g/ml}$.

Table 1 Apoptosis rates of SP2/0 cell line upon garlicin treatment for 48 h ($\bar{X} \pm \text{SD}$, n=3)

group	apoptotic rate(%)
control	1.3 \pm 0.11
2 $\mu\text{g/ml}$	12.23 \pm 0.94**
4 $\mu\text{g/ml}$	33.84 \pm 3.33**
6 $\mu\text{g/ml}$	44.77 \pm 4.27**
8 $\mu\text{g/ml}$	59.7 \pm 5.19**
10 $\mu\text{g/ml}$	62.4 \pm 5.66**

Statistical significance to control is marked with (*) ($P < 0.05$) and (**) ($P < 0.01$)

3.5 DNA alterations

After the initiation of apoptotic signaling, chromatinic DNA is cleaved by several families of nuclease that is specifically activated in programmed cell death. As it was shown in Figure 6, DNA ladders appeared in DNA samples extracted from garlicin treated SP2/0 cells, indicating that chromatin fragmentation had taken place.

3.6 Calcium dynamics

The cellular distribution of free calcium in SP2/0 cells suggested that there was a dose-dependent calcium release upon garlicin treatment at

48 h (Figure 7). The strongest positive signals occurred in the cells treated with 6 $\mu\text{g/ml}$, 8 $\mu\text{g/ml}$ and 10 $\mu\text{g/ml}$ garlicin, which gave rise to the hypothesis that garlicin induced apoptotic cascade were transduced in a large part by the accumulation of free calcium.

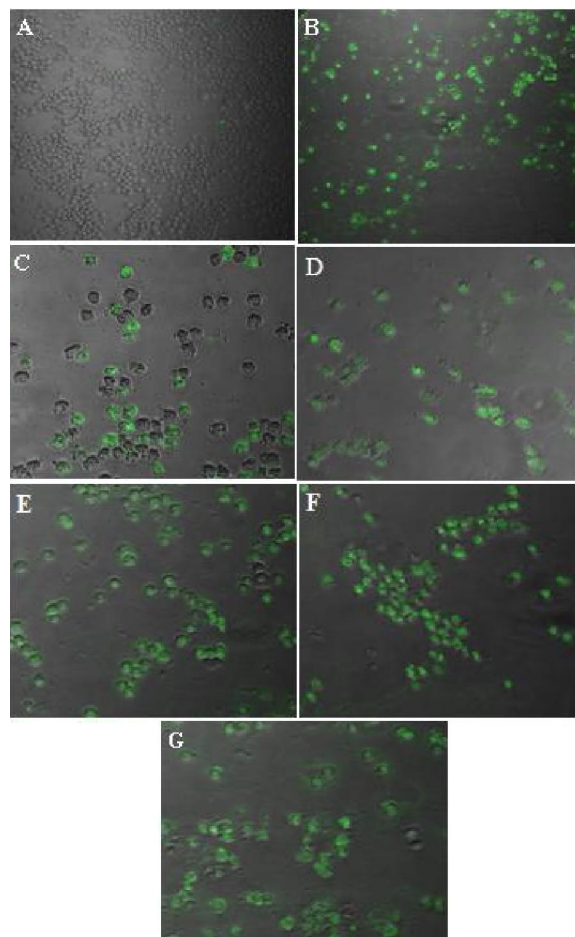

Figure 5. TUNEL staining of garlicin treated SP2/0 cells at 48 h. A. Negative control (10 \times); B. Positive control (10 \times); C. 2 $\mu\text{g/ml}$ (40 \times); D. 4 $\mu\text{g/ml}$ (40 \times); E. 6 $\mu\text{g/ml}$ (40 \times); F. 8 $\mu\text{g/ml}$ (40 \times); G. 10 $\mu\text{g/ml}$ (40 \times)

3.7 Cell cycle progression

At 48 h upon garlicin treatment, there were increasing proportions of populations in G1 phase and decreasing proportions of those in G2 phase with elevated garlicin concentration (Figure 8 and Table 2), indicating that cell cycle progression was likely to have been blocked at S/G2 checkpoint.

3.8 Mitochondrial transmembrane potential

Mitochondrial transmembrane potential of SP2/0 exhibited a dose-dependent decrease upon garlicin treatment at 48 h, which was regarded as a

symbolic event in apoptotic signalling cascade (Figure 9 and Table 3).

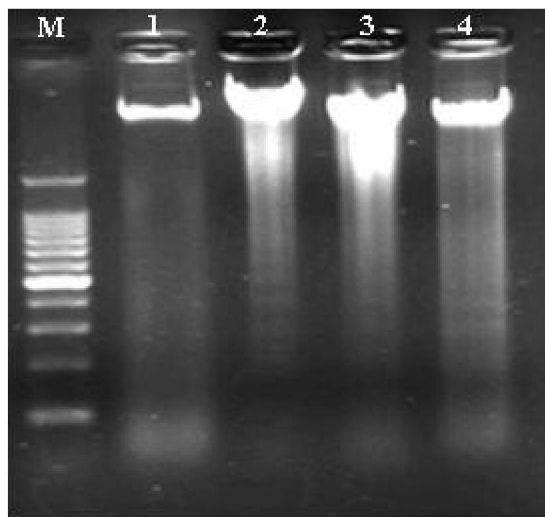

Figure 6. Electrophoresis image of sp2/0 cells treated with garlicin for 48 h. M. marker; 1. control; 2. 6 µg/ml; 3. 8 µg/ml; 4. 10 µg/ml.

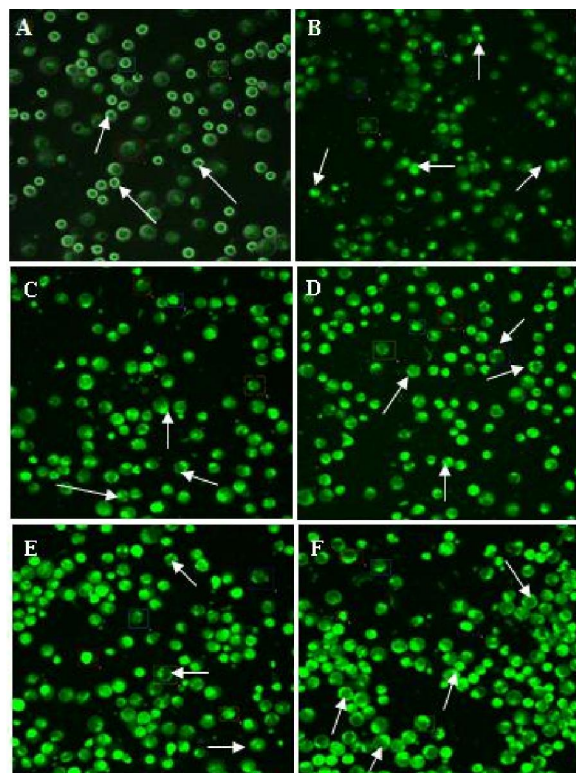

Figure 7. Calcium dynamics of SP2/0 cells treated with garlicin at 48 h (40×). (Arrow point to apoptotic cells) A. control; B. 2 µg/ml; C. 4 µg/ml; D. 6 µg/ml; E. 8 µg/ml; F. 10 µg/ml.

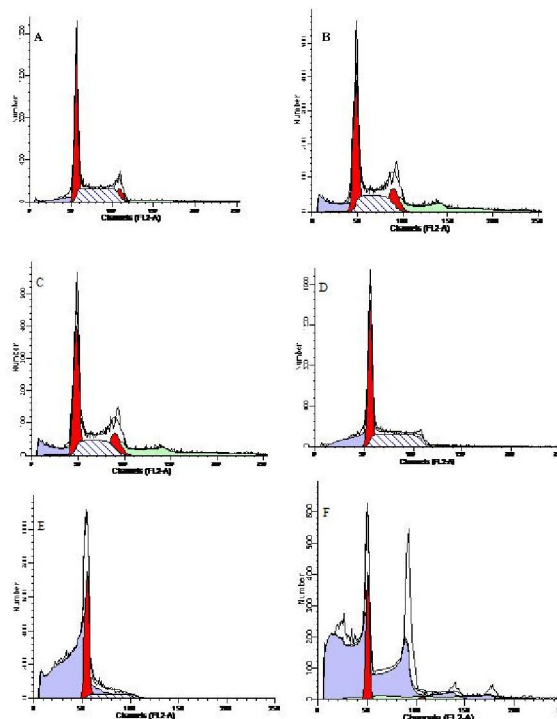

Figure 8. Cell cycle analysis of SP2/0 cells treated with garlicin for 48 h. A. control; B. 2 µg/ml; C. 4 µg/ml; D. 6 µg/ml; E. 8 µg/ml; F. 10 µg/ml.

Table 2 Cell cycle analysis of SP2/0 cells treated with garlicin for 48 h ($\bar{X} \pm SD$, n=3)

phase	G1(%)	S(%)	G2 (%)
control	41.24±5.66	44.17±4.78	8.45±1.34
2 µg/ml	49.76±6.48*	34.25±3.13*	15.80±2.39**
4 µg/ml	49.89±5.87*	32.12±3.39**	15.43±1.98**
6 µg/ml	55.70±5.92**	44.15±4.36	1.15±0.08**
8 µg/ml	79.68±6.48**	20.67±3.01**	0.06±0.01**
10 µg/ml	96.56±7.34**	0.09±0.01**	2.54±0.14**

Statistical significance to control is marked with (*) ($P < 0.05$) and (**) ($P < 0.01$)

4. Discussion

Tumorigenesis, a multi-step process evolves, rests gradually to a large extent on the deregulated tempo of cell division. It has been noted that drug elicited apoptosis of malignant cells is one of the efficacious therapies in clinical trials (Hino et al., 1996; Hirsch et al., 2000). This study adopted a variety of methods to detect cell proliferation and apoptosis, and the results we obtained proved that garlicin at a certain concentration inhibited the proliferation of SP2/0 cells and induced apoptosis, playing an outstanding role in anti-tumor.

4.1 Morphological observation

Apoptosis, which is defined as programmed cell death, has unique morphological characteristics, such as cell plasma membrane "blebbing", concentration of cytoplasm and nuclear material and chromatin, emergence of apoptotic bodies (Nagata, 1997). SP2/0 cells took on typical apoptotic morphology after treatment by garlicin.

4.2 Annexin V-FITC/PI double staining

In normal cells, phosphatidylserine (PS) is only found in the cytoplasmic surface of cell membrane. While in early apoptosis, PS is transferred to the extracytoplasmic surface by the inversion of cell membrane. Annexin V is a phospholipid binding protein with a high affinity for PS. Thus Annexin V is used frequently to detect early apoptosis. Annexin V-FITC/PI double staining is a better method on detection of apoptosis and distinction of necrotic cells (Shu et al., 2009). For PI can not go through the cell membrane in normal cells to stain the nuclei, but for necrotic cells. Compared with PI single staining, Annexin V-FITC/PI double staining can detect the early apoptotic cells more sensitively. Quantitative detection of apoptotic rate by flow cytometry showed that garlicin could induce apoptosis of SP2/0 cells with concentration-dependency.

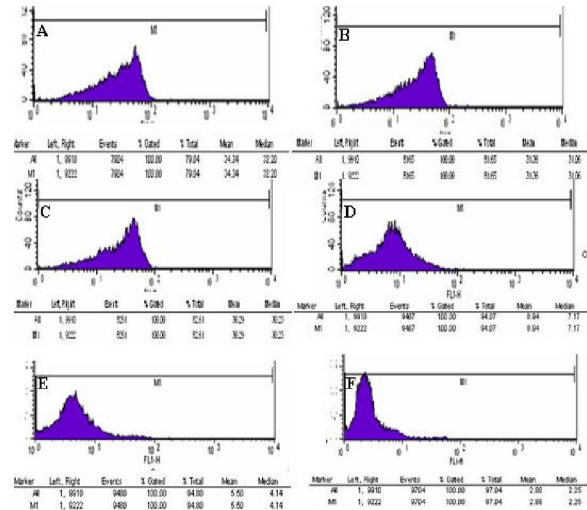

Figure 9. Mitochondrial transmembrane potential of SP2/0 cell with garlicin treatment for 48 h. A. control; B. 2 µg/ml; C. 4 µg/ml; D. 6 µg/ml; E. 8 µg/ml; F. 10 µg/ml.

Table 3 Mitochondrial transmembrane potential of SP2/0 cell with garlicin treatment for 48 h ($\bar{X} \pm SD, n=3$)

group	control	2 µg/ml	4 µg/ml	6 µg/ml	8 µg/ml	10 µg/ml
mitochondrial transmembrane potential ($\Delta\Psi$)	32.20±4.59	31.06±4.48	30.23±4.36	7.17±1.13**	4.14±1.12**	2.25±0.09**

Statistical significance to control is marked with (*) ($P<0.05$) and (**) ($P<0.01$)

4.3 DNA alterations

Cells experience specific cascade biochemical reactions during the process of apoptosis. The chromatin DNA is degraded, by activated endonuclease which is dependent on Ca^{2+} and Mg^{2+} , into 180bp - 200bp or multiple fragments that are called DNA ladders (Srivastava et al., 2009). DNA fracture is a landmark event in the late period of apoptosis. TUNEL method is considered one of the basic method to study apoptosis. Electrophoresis recorded the emergence of typical DNA ladders, and proved that garlicin can degrade chromatin DNA of SP2/0 cells into 180bp - 200bp. The results of TUNEL assay suggested that the treated cells, to the contrary of the control, exhibited higher apoptotic rate.

4.4 Calcium dynamics

In normal cells, Ca^{2+} is major combined with proteins that store in the endoplasmic reticulum and mitochondria. Generally there is little dissociative

Ca^{2+} , only when receiving external stimuli to release as signal molecule. Almost all the cell responses, involve contraction, exocytosis, gene expression and apoptosis, are controlled by the change of partial or total dissociative Ca^{2+} concentration. Research has shown that the excessive accumulation of intracellular free Ca^{2+} can lead to occurrence of apoptosis (Jiang et al., 1994). Accumulating evidence has linked intracellular Ca^{2+} signaling system closely with apoptosis. As a second message, cellular Ca^{2+} plays a pivotal role in apoptotic signaling cascade (Sakamoto et al., 1997). Intensified Ca^{2+} signal in garlicin treated cells at 48 h indicated that garlicin could induce apoptosis through the perturbation of Ca^{2+} homeostasis.

4.5 Cell cycle progression

It is generally believed that physiological and pathological apoptotic stimuli are also correlated with cell cycle progression (Siegers et al., 1999). Unscheduled proliferation constitutes a key step in

canceration, and an altered division speed would eventually lead to malignant transformation and neoplastic growth (Frantz et al., 2000). In current consideration, cell cycle arrest would induce apoptosis which occurs at the same stage, and regulation of cell cycle can affect cell apoptosis as well as cell proliferation. Many apoptotic stimulation signals affects apoptosis and cell cycle at the same time and in the same mechanism. Therefore, detection of cell cycle is a important apoptotic evaluation. On the other hand, through blocking cell cycle to induce apoptosis is a new target for anticancer drugs. DNA histograms of SP2/0 cells treated with garlicin were detected and the results showed that garlicin influenced cell cycle progression in a dose-dependent manner. The percentage of population in G₁ and S phase increased and that in G₂ phase decreased, indicating that cell cycle was arrested at G₁/S checkpoint. It is herein speculated that garlicin could exert a disruption effect on the DNA replication of SP2/0 cells, affect distribution of cell cycle, and promote apoptosis finally. This study will provide important experimental basis for the future mechanism study of garlicin induced apoptosis in SP2/0 cells.

4.6 Mitochondrial transmembrane potential

In the apoptosis process, many important events are closely related with the mitochondria (Bouchier-Hayes et al., 2005). The study of apoptosis mechanism shows that mitochondria play a key role in the process of apoptosis. Concretely, mitochondrial transmembrane potential decreases when cell apoptosis is induced (Armstrong, 2006), leading to the increase of membrane permeability and open of mitochondrial permeability transition pores (Dias et al., 2005; Lucken-Ardjomande et al., 2005), where after, the cytochrome C (Mohamad et al., 2005), apoptosis inducing factor (AIF) (Liu et al., 1997), etc. enter the cytoplasm, causing the apoptosis. The decline of mitochondrial transmembrane potential is considered to be the first event during apoptotic cascade reactions, it occurs before occurrence of apoptotic characteristics of cell nuclei. Flow cytometry is commonly used to detect the change of mitochondrial transmembrane potential.

In this study, cells were labeled with Rh-123 to detect the change of mitochondrial transmembrane potential using flow cytometry. Decrease of mitochondrial transmembrane potential took place when the SP2/0 cells were treated with garlicin. Consonantly membrane permeability increase, cytochrome C enter the cytoplasm from mitochondria, and combine with apoptotic protease activating factor-1, activate Caspase-9, then activate Caspase-3, start Caspase cascade reaction, promote

apoptosis. Our finding that garlicin induces apoptosis of SP2/0 cells relate to mitochondrial pathway further supports the important role of mitochondria in apoptotic cascade reactions.

Acknowledgements:

The work was supported by the "863" National Major Research Program (2007AA10Z170), the central level, scientific research institutes for R & D special fund business (2011cj-9), and the project National Infrastructure of Animal Germplasm Resources (2012 year).

Corresponding Author:

Pro. Weijun Guan and Pro. Yuehui Ma
Institute of Animal Science, Chinese Academy of Agricultural Sciences, Beijing 100193, China
E-mail: Yuehui_Ma@hotmail.com;
weijunguan301@gmail.com

References

1. Lv YX, Li W, Yan YQ. The effect of allicin on inducing tumor cells apoptosis. *Journal of Modern Oncology* 2006;14 (1):117-118.
2. Velmurugan B, Bhuvanewari V, Nagini S. Effect of S-allylcysteine on oxidant-antioxidant status during N-methyl-N'-nitro-N-nitrosoguanidine and saturated sodium chloride-induced gastric carcinogenesis in Wistar rats. *Asia Pac J Clin Nutr* 2003;12(4):488-94.
3. Leist M, Raab B, Maurer S, Rösick U, Brigelius-Flohé R. Conventional cell culture media do not adequately supply cells with antioxidants and thus facilitate peroxide-induced genotoxicity. *Free Radical Biology and Medicine* 1996;21(3):297-306.
4. Freshney RI. *Culture of Animal Cells: A Manual of Basic Technique*, 4th ed. 2000. Wiley-Liss, New York.
5. Guan WJ, Ma YH, Zhou XY, Liu GL, Liu XD. The establishment of fibroblast cell line and its biological characteristic research in Taihang black goat. *Review of China Agricultural Science and Technology* 2005;7:25-33.
6. Zhou XM, Ma YH, Guan WJ, Zhao DM. Establishment and identification of Debao pony ear marginal tissue fibroblast cell line. *Asian-Australian Journal of Animal Science* 2004;17(10):1338-1343.
7. Gu Y, Li H, Miki J, Kim KH, Furusato B, Sesterhenn IA, Chu WS, McLeod DG, Srivastava S, Ewing CM, Isaacs WB, Rhim

- JS. Phenotypic characterization of telomerase-immortalized primary non-malignant and malignant tumor-derived human prostate epithelial cell lines. *Exp Cell Res*. 2006;312(6):831-843.
8. Kong D, Nishino N, Shibusawa M, Kusano M. Establishment and characterization of human pancreatic adenocarcinoma cell line in tissue culture and the nude mouse. *Tissue and Cell* 2007; 39(4):217-223.
 9. Zhang HT, Feng ZL, Wu J, Wang YJ, Guo X, Liang NC, Zhu ZY, Ma JQ. Sodium butyrate-induced death-associated protein kinase expression promote Raji cell morphological change and apoptosis by reducing FAK protein levels. *Acta Pharmacologica Sinica* 2007; 28(11):1783-1790.
 10. Zhang HT, Wu J, Zhang HF, Zhu QF. Efflux of potassium ion is an important reason of HL-60 cells apoptosis induced by tachyplesin. *Acta Pharmacologica Sinica* 2006;27(10):1367-1374.
 11. Hino N, Higashi T, Nouse K, Nakatsukasa H, Tsuji T. Apoptosis and proliferation of human hepatocellular carcinoma. *Liver* 1996;16(2):123-129.
 12. Hirsch K, Danilenko M, Giat J, Miron T, Rabinkov A, Wilchek M, Mirelman D, Levy J, Sharoni Y. Effect of purified allicin, the major ingredient of freshly crushed garlic, on cancer cell proliferation. *Nutr Cancer* 2000;38(2):245-254.
 13. Nagata S. Apoptosis by death factor. *Cell*. 1997;88(3):355-365.
 14. Shu B, Duan W, Yao J, Huang J, Jiang Z, Zhang L. Caspase 3 is involved in the apoptosis induced by triptolide in HK-2 cells. *Toxicol In Vitro* 2009;23(4):598-602.
 15. Srivastava V, Rawall S, Vijayan VK, Khanna M. Influenza a virus induced apoptosis: inhibition of DNA laddering & caspase-3 activity by zinc supplementation in cultured HeLa cells. *Indian J Med Res* 2009;129(5):579-586.
 16. Jiang S, Chow SC, Nicotera P, Orrenius S. Intracellular Ca^{2+} signals activate apoptosis in thymocytes: studies using the Ca^{2+} -ATPase inhibitor thapsigargin. *Exp Cell Res* 1994;212(1):84-92.
 17. Sakamoto K, Lawson LD, Milner JA. Allyl sulfides from garlic suppress the in vitro proliferation of human A549 lung tumor cells. *Nutrition and Cancer* 1997;29(2):152-156.
 18. Siegers CP, Steffen B, Röbbke A, Pentz R. The effects of garlic preparations against human tumor cell proliferation. *Phytomedicine*. 1999;6(1):7-11.
 19. Frantz DJ, Hughes BG, Nelson DR, Murray BK, Christensen MJ. Cell cycle arrest and differential gene expression in HT-29 cells exposed to an aqueous garlic extract. *Nutrition and Cancer*. 2000;38(2):255-264.
 20. Bouchier-Hayes L, Lartigue L, Newmeyer DD. Mitochondria: pharmacological manipulation of cell death. *J Clin Invest* 2005;115(10):2640-2647.
 21. Armstrong J S. Mitochondrial membrane permeabilization: the sine qua non for cell death. *BioEssays* 2006;28(3):253-260.
 22. Dias N, Bailly C. Drugs targeting mitochondrial functions to control tumor cell growth. *Biochem Pharmacol* 2005;70(1):1-12.
 23. Lucken-Ardjomande S, Montessuit S, Martinou JC. Changes in the outer mitochondrial membranes during apoptosis. *J Soc Biol* 2005;199(3):207-210.
 24. Mohamad N, Gutiérrez A, Núñez M, Cocca C, Martín G, Cricco G, Medina V, Rivera E, Bergoc R. Mitochondrial apoptotic pathways. *Biocell* 2005;29(2): 149-161.
 25. Liu X, Zou H, Slaughter C, Wang X. DFF, a heterodimeric protein that functions downstream of caspase-3 to trigger DNA fragmentation during apoptosis. *Cell* 1997;89(2):175-184.

11/21/2012

Calculation of Generation System Reliability Index: Loss of Load Expectation

Mehdi Nikzad, Shoorangiz Shams Shamsabad Farahani, Mohammad Bigdeli Tabar, Hossein Tourang, Behrang Yousefpour

Department of Electrical Engineering, Islamshahr Branch, Islamic Azad University, Tehran, Iran
mehdi.nikzad@yahoo.com

Abstract: Generation system reliability is an important factor in the long term planning for future system capacity expansion to make sure that the total installed capacity is sufficient to support demand. The planning process utilizes reliability indices as criteria to decide on new investments in new generation capacities. Generation system reliability is evaluated by using different indexes. In this paper, loss load of expectation (LOLE) is simulated to evaluate the system reliability. Effects of the system parameters such as forced outage rate (FOR) are tested on the LOLE index.

[Mehdi Nikzad, Shoorangiz Shams Shamsabad Farahani, Mohammad Bigdeli Tabar, Hossein Tourang, Behrang Yousefpour. **Calculation of Generation System Reliability Index: Loss of Load Expectation.** *Life Sci J* 2012;9(4):3595-3599]. (ISSN: 1097-8135). <http://www.lifesciencesite.com>. 532

Keywords: Generation System Reliability, Loss of Load Expectation, Capacity Outage Probability Table, Analytically Method

1. Introduction

Electricity has been the driving force for economies of the world and provides day-to-day necessity for the population in the world. The generation, transmission and retailing of electricity have existed hundreds of years in providing the much needed electricity. Due to the nature of electricity systems, the variable demand at every moment needs to be met by consistent electricity supply in making sure the continuous availability of the resources. Not meeting the demand in any case will lead to a huge loss of income to the generators as well as to the consumers. The reliability of the generation, transmission and distribution of electricity in this sense is crucial for the continuous supply of electricity to meet the demand.

A modern power system is complex, highly integrated and very large. Fortunately, the system can be divided into appropriate subsystems or functional areas that can be analyzed separately [1]. These functional areas are generation, transmission and distribution. The function of the generation system is to make sure enough capacity is available to meet the load/demand at any time. Transmission and distribution systems need to be reliable in making sure the electricity generator can be delivered to the consumers. System planners have been assigned the role of planning for forecasting the load into the future and plant capacity addition to meet the load and provide a level of reliability in case some of the plants are out on maintenance or breakdown. Probabilistic method is often used to determine the system reliability and the system reliability can be summed up into a single value, the reliability indices. Reliability studies are conducted for two purposes.

Long-term evaluations are performed to assist in system planning and short-term evaluations to assist in day to day operating decisions. In short, these reliability indices (for long-term evaluations) are used by system planners and the authorities to decide on and advice for new investments in building new generation capacities [1].

Generation system reliability is an important aspect in the planning for future system capacity expansion. It provides a measurement of reliability or adequacy to make sure that the total generation system capacity is sufficient to provide adequate electricity when needed [1].

In this paper an important reliability index LOLE is evaluated for generation system. The proposed index is simulated by using analytically method. Effects of changing system parameters such as FOR are tested on the LOLE.

2. Generation system reliability

Reliability has been and always is one of the major factors in the planning, design, operation, and maintenance of electric power system. Generation system reliability focuses on the reliability of generators in the whole electric power system where electric power is produced from the conversion process of primary energy (fuel) to electricity before transmission. The generation system is an important part of the electricity supply chain and it is crucial that enough electricity is generated at every moment to meet the demand. Generating units will occasionally fail to operate and the system operator has to make sure that enough reserve is available to be operated when this situation happens [2-31].

Reliability of the generation system is divided into adequacy and security [32]. System adequacy

relates to the existence of sufficient generators within the system to satisfy the consumer load demand or system operational constraints. System adequacy is associated with static conditions of the system and do not include system disturbances. System security on the other hand relates to the ability of the system to respond to disturbances arising within the system. Therefore system security is associated with the response of the system to whatever perturbation it is subjected to. In this study, the reliability evaluations will be focused on the generation system adequacy and will not take into account system security.

The basic modeling approach for the generating system adequacy assessment consists of three parts as shown in Figure 1. The generation and load models are convolved to form an appropriate risk model where the element of interest is the risk of generation capacity less than the load. In short, adequacy evaluation of generation systems consists of four general steps as Figure 1:

(i) Create a generation capacity model; (ii) create a load model; (iii) combined the generation capacity model with load model to obtain a risk model and (iv) calculating indexes.

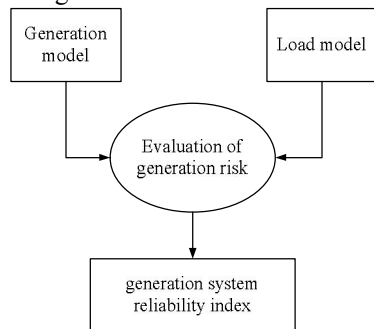

Figure 1: Generation reliability evaluation process

Analytical methods or Monte Carlo simulation [33] can be used to calculate the reliability indices. Analytical techniques represent the system by analytical models and evaluate the indices from these models using mathematical solutions. Monte Carlo simulations, on the other hand estimate the indices by simulating the actual process and random behavior of the system, treating the problem as a series of experiments. The reliability indices obtained indicate the ability of the generating facilities to meet the system demand.

In the analytical method, the generating system model used for generation capacity adequacy assessment is a Capacity Outage Probability Table (COPT) which can be created using the recursive technique. As for the load model, the daily peak load or hourly load for a period of one year is normally used to form the Load Probability Table (LPT).

3. Load model

The load in a power system in any time period is a stochastic process, which is difficult to describe with a simple mathematical formula. Different models are created, starting from primary load data and according to the need to calculate reliability. Primary load data will provide a minimum amount of data that is needed to establish an hourly chronological load profile. Most primary load data consist of the percentage of maximum monthly load or weekly load in a year, the load in 24 hours in a typical day in each season and the maximum load in each day in a week. With the percentages of these data available and the annual peak load known, the hourly chronological load profile can be established.

4. Forced Outage Rate

There are many concepts in reliability evaluation such as: failure rate, repair time, unavailability, forced outage rate (FOR) and etc. Unit unavailability is also known conventionally as “forced outage rate” (FOR), although the value is not a rate. The FOR is defined as below.

$$FOR = \frac{\text{Forced outage hours}}{\text{Forced outage hours} + \text{In service hours}} \quad (1)$$

The FOR is calculated for a long period of time (e.g. 365 days), is the same index as the unavailability.

5. Generation system reliability indices

The quantification of reliability is an important aspect of generation system reliability assessment. The measurement used to quantify reliability of a generation system is given various reliability indices. These reliability indices are used to assess the reliability performance of a generation system against some predetermined minimum requirements or reliability standards, compare alternative designs, identify weak spots and determine ways for correction in the generation system and to be integrated with costs and performance considerations for decision making. These indices are better understood as estimates of system-wide generation adequacy and not as absolute measures of system reliability [18].

Basically, system reliability evaluations can be divided into deterministic and probabilistic. The most common deterministic indices are the Reserve Margin and the largest set in the system. An important shortcoming of these methods is that they do not account for the stochastic nature of system behavior.

Probabilistic methods can provide more meaningful information to be used in design and resource in planning and allocation. There are two approaches that use probabilistic evaluation. The analytical methods and Monte Carlo simulation as

can be seen from Figure 2. The analytical methods represent the system by mathematical models and use direct analytical solutions to evaluate reliability indices from the model. As for the Monte Carlo simulation, reliability indices are estimated by simulating the actual random behavior of the system. So of the commonly used probabilistic reliability indices are Loss of Load Probability (LOLP), Loss of Load Expectation (LOLE), Loss of Energy Probability (LOEP), Loss of Energy Expectation (LOEE), Expected Energy Not Served (EENS), and Loss of Load Frequency (LOLF) and Loss of Load Duration (LOLD). Most of these indices are basically expected values of a random variable. Expectation indices provide valid adequacy indicators which reflect various factors such as system component availability and capacity, load characteristics and uncertainty, system configurations and operational conditions, etc [1]. Typical reliability indices used in power system evaluations and their categorizing is shown in Figure 2.

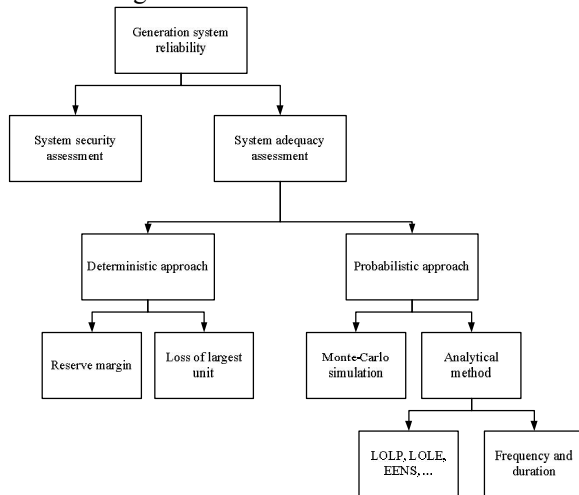

Figure 2: Generation system reliability assessment indices category

6. Loss of load expectation

The LOLE risk index is the most widely accepted and used probabilistic method in system reliability evaluation for generating systems. Two models are required and employed. One is the previously studied Load Duration Curve (LDC), and the other is the COPT. These two models are convolved (combined) in the process. The unit of the LOLE is in days per year (d/y) or hours per year (h/y). The LOLE evaluation method is expressed in the following mathematical formula:

$$LOLE = \sum P_{O_i} \times T_{O_i} \quad (2)$$

where, P_{O_i} : probability of capacity outage i and T_{O_i} : time of capacity outage i (h/year).

It is clear that the capacity outages less than the reserve will not cause a loss of load.

7. Case study

In this section a numerical case study is carried out for reliability evaluation. Table 1 shows the proposed generation test system. This system contains four generation companies with six units. The system data and capacity of units are considered as typical. The load model is also considered as Figure 3.

Table 1: Generation system details

Generation Company	Number of units	Capacity of each unit (MW)	FOR
1	2	25	0.03
2	2	40	0.02
3	1	50	0.01
4	1	100	0.01

Table 2: COPT for the test system

Capacity Outage (MW)	Probability
0	0.88565791683600000
25	0.05478296392800000
40	0.03614930272800000
50	0.00894603956400000
50	0.00084715923600000
65	0.00223603934400000
75	0.00055336327200000
80	0.00036887043600000
90	0.00036514447200000
90	3.457792800000000e-05
100	0.00894603956400000
100	8.557164000000000e-06
105	2.281672800000000e-05
115	2.258625600000000e-05
125	0.00055336327200000
130	3.725964000000000e-06
130	3.528360000000000e-07
140	0.00036514447200000
140	3.492720000000000e-07
150	9.036403600000000e-05
150	8.557164000000000e-06
155	2.304720000000000e-07
165	2.258625600000000e-05
175	5.589528000000000e-06
180	3.725964000000000e-06
180	3.564000000000000e-09
190	3.688328000000000e-06
190	3.492720000000000e-07
200	8.643600000000000e-08
205	2.304720000000000e-07
215	2.281440000000000e-07
230	3.763600000000000e-08
230	3.564000000000000e-09
240	3.528000000000000e-09
255	2.328000000000000e-09
280	3.600000000000000e-11
	Sum of probabilities=1

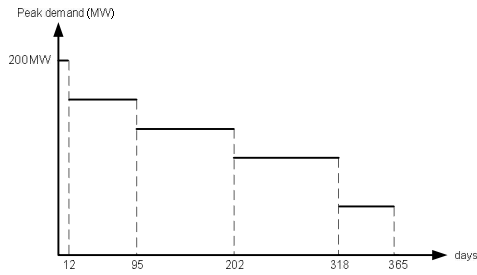

Figure 3: Daily peak demand of year

8. Simulation results

In this section LOLE index is calculated for the proposed test system. The procedure presented in section 6 is used to computing LOLE. In first the Capacity Outage Probability Table (COPT) is derived. Table 2 shows the COPT and the probability of different outages is listed.

LOLE index is calculated as mentioned above. In this regard, the LOLE is obtained as below.

$$LOLE = 5.2281 \text{ (h/year)} \quad (3)$$

In order to show the sensitivity of LOLE index to the system parameters, an evaluation is carried out and the results are listed in Table 3. It is seen that changing FORs and load has a direct effect of the reliability of generation system.

Table 3: Effect of changing parameters on the LOLE index

Parameter changing	LOLE (h/year)
FOR unit 25 MW=0.01	4.4183
FOR unit 25 MW=0.05	6.0350
FOR unit 40 MW=0.05	6.7380
FOR unit 50 MW=0.05	6.5868
FOR unit 100 MW=0.1	50.9910
Increasing load by 10% in all levels	7.4467
decreasing load by 10% in all levels	1.4118

Conclusions

In this paper a commonly used reliability index of generation system LOLE was successfully calculated and evaluated. Different conditions and changing were considered. COPT was carried out and then the reliability calculated. Simulation results showed that changing components FOR and load level can directly affect of the system total reliability.

Corresponding Author:
Mehdi Nikzad,

Department of Electrical Engineering, Islamshahr Branch, Islamic Azad University, Tehran, Iran.
Email: mehdi.nikzad@yahoo.com

References

[1] R. Billinton, R.J. Ringlee, A.J. Wood, Power-system reliability calculations, 1973.

[2] R. Arya, S.C. Choube, L.D. Arya, Reliability evaluation and enhancement of distribution systems in the presence of distributed generation based on standby mode, International Journal of Electrical Power & Energy Systems, 43 (2012) 607-616.

[3] A.K. Azad, R.B. Misra, A new approach to evaluate reliability and production cost of a power generating system, Computers & Electrical Engineering, 22 (1996) 343-351.

[4] B. Banerjee, S.M. Islam, Reliability based optimum location of distributed generation, International Journal of Electrical Power & Energy Systems, 33 (2011) 1470-1478.

[5] J. Batut, J. Boisseau, E. Bourgade, M. Monti, Different approaches to reliability as applied to the generation — transmission system and its components, International Journal of Electrical Power & Energy Systems, 10 (1988) 168-173.

[6] R. Billinton, T.K.P. Medicherla, Effect of system peak load forecast uncertainty on annualized reliability indices of composite generation and transmission systems, Microelectronics Reliability, 20 (1980) 91-100.

[7] R. Billinton, X. Tang, Selected considerations in utilizing Monte Carlo simulation in quantitative reliability evaluation of composite power systems, Electric Power Systems Research, 69 (2004) 205-211.

[8] C.L.T. Borges, An overview of reliability models and methods for distribution systems with renewable energy distributed generation, Renewable and Sustainable Energy Reviews, 16 (2012) 4008-4015.

[9] C.L.T. Borges, D.M. Falcão, Optimal distributed generation allocation for reliability, losses, and voltage improvement, International Journal of Electrical Power & Energy Systems, 28 (2006) 413-420.

[10] H.-C. Chen, Optimum capacity determination of stand-alone hybrid generation system considering cost and reliability, Applied Energy.

[11] D.P. Clancy, G. Gross, F.F. Wu, Probabilistic flows for reliability evaluation of multiarea power system interconnections, International

- Journal of Electrical Power & Energy Systems, 5 (1983) 101-114.
- [12] S. Fockens, A.J.M. van Wijk, W.C. Turkenburg, C. Singh, Reliability analysis of generating systems including intermittent sources, International Journal of Electrical Power & Energy Systems, 14 (1992) 2-8.
- [13] S. Fockens, A.J.M. van Wijk, W.C. Turkenburg, C. Singh, Application of energy based indices in generating system reliability analysis, International Journal of Electrical Power & Energy Systems, 16 (1994) 311-319.
- [14] H. Haroonabadi, M.R. Haghifam, Generation reliability assessment in power markets using Monte Carlo simulation and soft computing, Applied Soft Computing, 11 (2011) 5292-5298.
- [15] Y.-Y. Hong, L.-H. Lee, Reliability assessment of generation and transmission systems using fault-tree analysis, Energy Conversion and Management, 50 (2009) 2810-2817.
- [16] A. Jain, S.C. Tripathy, R. Balasubramanian, Reliability and economic analysis of a power generation system including a photovoltaic system, Energy Conversion and Management, 36 (1995) 183-189.
- [17] D. Kottick, M. Blau, Y. Frank, Reliability of supply to consumers as a function of the installed generation reserve margin, Electric Power Systems Research, 33 (1995) 63-67.
- [18] S.R. Lakshmi, S.C. Tripathy, K.S.P. Rao, R. Balasubramanian, Evaluation of generation system reliability indices by fast transform techniques, International Journal of Electrical Power & Energy Systems, 17 (1995) 281-287.
- [19] T. Lekane, J. Gheury, J. Van Hecke, Assessing the impact of operating constraints and operating policy on the reliability level of a generation system, International Transactions in Operational Research, 3 (1996) 271-279.
- [20] Y.-F. Li, E. Zio, A multi-state model for the reliability assessment of a distributed generation system via universal generating function, Reliability Engineering & System Safety, 106 (2012) 28-36.
- [21] S. Narasimhan, S. Asgarpoor, A fuzzy-based approach for generation system reliability evaluation, Electric Power Systems Research, 53 (2000) 133-138.
- [22] P. Pelacchi, D. Poli, The influence of wind generation on power system reliability and the possible use of hydrogen storages, Electric Power Systems Research, 80 (2010) 249-255.
- [23] M.V.F. Pereira, S.H.F. Cunha, G.C. Oliveira, Application of reliability evaluation methods to the planning of large hydroelectric systems, International Journal of Electrical Power & Energy Systems, 10 (1988) 142-150.
- [24] O. Salmela, The effect of introducing increased-reliability-risk electronic components into 3rd generation telecommunications systems, Reliability Engineering & System Safety, 89 (2005) 208-218.
- [25] W.-H. Shi, J. Chen, Reliability Assessment of Interconnected Generation Systems Based on Hourly Wind Speed Probability Model, Energy Procedia, 12 (2011) 819-827.
- [26] C. Singh, N.V. Gubbala, An alternative approach to rounding off generation models in power system reliability evaluation, Electric Power Systems Research, 36 (1996) 37-44.
- [27] C. Singh, N.V. Gubbala, Comparison of unit addition and fast Fourier transform methods for generation system reliability evaluation, International Journal of Electrical Power & Energy Systems, 18 (1996) 203-205.
- [28] R. Sundaramurthi, C. Smidts, Human reliability modeling for the Next Generation System Code, Annals of Nuclear Energy.
- [29] A.K. Verma, A. Srividya, B.C. Deka, Impact of a FACTS controller on reliability of composite power generation and transmission system, Electric Power Systems Research, 72 (2004) 125-130.
- [30] Z.A. Yamayee, F.S. Ma, Effect of size and location of conventional and intermittent generation on system reliability, International Journal of Electrical Power & Energy Systems, 5 (1983) 94-100.
- [31] X. Zhang, Z. Bie, G. Li, Reliability Assessment of Distribution Networks with Distributed Generations using Monte Carlo Method, Energy Procedia, 12 (2011) 278-286.
- [32] R. Billinton, E. Khan, A security based approach to composite power system reliability evaluation, Power Systems, IEEE Transactions on, 7 (1992) 65-72.
- [33] O. Alizadeh Mousavi, R. Cherkaoui, M. Bozorg, Blackouts risk evaluation by Monte Carlo Simulation regarding cascading outages and system frequency deviation, Electric Power Systems Research, 89 (2012) 157-164.

11/23/2012

Factors affecting adherence level to HAART (Adherence predictors) in Kuala Lumpur, MalaysiaUmar Yagoub^{*1}, Bulgiba A¹, Peramalah D¹, Lee C², Chik Z³¹ Julius Centre University of Malaya, Department of Social and Preventive Medicine, Faculty of Medicine, University of Malaya, 50603 Kuala Lumpur, Malaysia² Department of Medicine, Sungai Buloh Hospital, 47000 Sungai Buloh Selangor Malaysia³ University of Malaya Bioequivalence and Testing Center (UBAT), Department of Pharmacology, Faculty of Medicine, University of Malaya, 50603 Kuala Lumpur, Malaysiamohammedumar2001@yahoo.com

Abstract: Adherence to Highly Active Antiretroviral Treatment (HAART) is the most important factor in predicting an HIV-infected patient treatment outcome. The objective of this paper is to examine the key determinants of adherence to HAART in a resource-limited setting. A total of 925 HIV-infected patients on antiretroviral treatment were studied using a self-reported adherence questionnaire. We analysed the data using multiple logistic regression. We found that adherence was less likely if the patient had diarrhoea (aOR=0.081; 95% CI 0.034-0.192), vomiting (aOR=0.131; 95% CI 0.058-0.294), simply forgot their medication (aOR=0.080; 95% CI 0.033-0.197), used herbal medicine (aOR=0.227; 95% CI 0.103-0.501), used religious treatment (aOR=0.067; 95% CI 0.027-0.165) or had to travel too far to get their medication (aOR=0.264; 95% CI 0.111-0.632). Adherence was more likely with the use of the alarm clock (aOR=6.712; 95% CI 2.747-16.397), if they accepted their HIV status (aOR=4.727; 95% CI 1.960-11.403), had self-efficacy (aOR=4.711; 95% CI 2.062-10.761); were older (aOR=5.119; 95% CI 2.159-12.14), had higher education (aOR=1.430; 1.108-1.844) and had higher income (aOR=9.993; 95% CI 3.175-31.454). In conclusion, healthcare providers should treat adverse effects as effectively as possible, discourage the use of alternative treatments, provide counselling, encourage the alarm clock use and look into providing HAART closer to the patient's home to improve adherence.

[Umar Yagoub, Bulgiba AM, Peramalah D, Lee C, Chik Z. **Factors affecting adherence level to HAART (Adherence predictors) in Kuala Lumpur, Malaysia.** *Life Sci J* 2012;9(4):3600-3603] (ISSN:1097-8135). <http://www.lifesciencesite.com>. 533

Keywords: HAART, HIV, self-reported, adherence predictors

1. Introduction

The provision of Highly Active Antiretroviral Therapy (HAART) has been credited with having a positive effect on the lives of people living with HIV/AIDS in Malaysia (Mazlan et al., 2006; Wolfe et al., 2010). Many factors have been associated with patients' behaviour of taking HIV/AIDS medication correctly as prescribed by their physician (Chesney, 2000; Do et al., 2010; Maqutu et al., 2010).

To our knowledge there have been no published studies in Malaysia on adherence to HAART and associated factors in HIV positive patients on HAART. Thus, in this study we aimed at determining the factors affecting the adherence level in HIV-positive patients in the Malaysian setting.

2. Material and Methods

This study was conducted between October 2010 and November 2011 in a large tertiary level infectious disease-focused hospital in Malaysia. Nine hundred and twenty five adult (18 years and above) HIV-positive Malaysian nationals receiving HAART were recruited into a perspective cohort study aimed

at studying adherence to HAART. This paper is from the first part of that study.

Eligible participants filled a culturally adapted and modified self-reported Adult Clinical Trial Group (ACTG) follow up questionnaire which has been used in many international studies (M. A. Chesney et al., 2000; M.A. Chesney et al., 2000; Gross et al., 2009; Levine et al., 2006; Peltzer et al., 2010)

Collected data were entered into SPSS version 16, checked for consistency and cleaned. Multiple logistic regression was used to determine the effect of independent variables on the dichotomized adherence level measured by overall self-reported adherence questionnaire. Odds ratios were computed with 95% CI and interpreted accordingly. This study was approved by both the University of Malaya Medical Centre Research Ethics Committee (IRP Reference # 714.14) and Ministry of Health Malaysia.

3. Results

Of the eligible participants or 925 participants (94.6%) completed the questionnaire and their data was analyzed. The majority were males

(76.3%), Chinese (63.2%), aged 31-34 years (36.5%), who were married (62.3%). Table 1 displays their

socio-demographic characteristics. Table 2 displays the final multiple logistic regression model results.

Table 1: Socio-demographic characteristics of adherent and non-adherent HIV positive patients using self-reported adherence questionnaire

Variable	Adherent (%)	Not Adherent (%)	Total (%)	OR (95%CI)
Gender				
Female	171 (78.1)	48 (21.9)	219 (23.7)	Reference category
Male	585 (82.9)	121 (17.1)	706 (76.3)	0.736 (0.506, 1.072)
Total	756 (81.7)	169 (18.3)	925 (100)	
Religion				
Islam	215 (83.3)	43 (16.7)	258 (27.9)	Reference category
Buddhism	368 (82.1)	80 (17.9)	448(48.4)	0.794 (0.171, 3.692)
Hinduism	40 (75.5)	13 (24.5)	53 (5.7)	0.270 (0.034, 2.117)
Christianity	82 (84.5)	15 (15.5)	97 (10.5)	1.232 (0.234, 6.478)
Taoism	39 (70.9)	16 (29.1)	55 (5.9)	0.312 (0.056, 1.725)
Others	12 (85.7)	2 (14.3)	14 (1.5)	0.794 (0.082, 7.651)
Total	756 (81.7)	169 (18.3)	925 (100)	
Ethnicity				
Malay	209 (83.6)	41 (16.4)	250 (27.0)	Reference category
Chinese	474 (81.0)	111 (19.0)	585 (63.2)	1.154 (0.245, 5.433)
Indian	57 (79.2)	15 (20.8)	72 (7.8)	2.356 (0.304, 18.272)
Others	16 (88.9)	2 (11.1)	18 (1.9)	7.678 (0.715, 82.402)
Total	756 (81.7)	169 (18.3)	925 (100)	
Completed Educational				
No formal schooling	55 (46.6)	63 (53.4)	118 (12.8)	Reference category
Primary school	108 (72.5)	41 (27.5)	149 (16.1)	8.544 (3.490, 20.914)
Secondary school – 3	222 (88.4)	29 (11.6)	251 (27.1)	26.924 (11.009, 65.848)
Secondary school – 5	200 (93.0)	15 (7.0)	215 (23.2)	9.71 (3.618, 26.064)
High school (form6 level)	51 (85.0)	9 (15.0)	60 (6.5)	4.053 (1.225, 13.41)
Diploma	36 (87.8)	5 (12.2)	41 (4.4)	5.454 (1.161, 25.630)
Degree	84 (92.3)	7 (7.7)	91 (9.8)	6.574 (2.018, 21.42)
Total	756 (81.7)	169 (18.3)	925 (100)	
Marital status				
Single	225 (64.5)	124 (35.5)	349 (37.7)	Reference category
Married	531 (92.2)	45 (7.8)	576 (62.3)	6.503 (4.469, 9.462)
Total	756 (81.7)	169 (18.3)	925 (100)	
Average monthly income				
≤RM 1,500 / Month	228 (62.3)	138 (37.7)	366 (39.5)	Reference category
RM 1,501—2,500	227 (93.8)	15 (6.2)	242 (26.2)	7.708 (4.148, 14.323)
RM 2,501—10,000	301 (95.0)	16 (5.0)	317 (34.3)	2.488 (1.127, 5.490)
Total	756 (81.7)	169 (18.3)	925 (100)	
Age group in years				
18—30	210(63.6)	120 (36.4)	330 (35.7)	Reference category
31—44	312 (92.3)	26 (7.7)	338 (36.5)	10.877 (4.944, 23.927)
45 or more	234 (91.1)	23 (8.9)	257 (27.8)	21.379 (9.446, 48.386)
Total	756 (81.7)	169 (18.3)	925 (100)	

Demographic factors examined – gender, religion, ethnicity, completed educational, marital status average monthly income and age group in years.

Table 2: Final multiple logistic regression model on factors affecting self-reported adherence

Variables (Yes versus No)	Crude odds ratio (95% CI)	Adjusted Odds ratio (95% CI)
Diarrhoea	0.107 (0.074, 0.155)	0.081 (0.034, 0.192)
Vomiting	0.099 (0.068, 0.144)	0.131 (0.058, 0.294)
Use of religious treatment	0.071 (0.049, 0.105)	0.067 (0.027, 0.165)
Use of herbal medicine	0.302 (0.214, 0.426)	0.227 (0.103, 0.501)
Use of Alarm /Clock	7.057 (4.445, 11.205)	6.712 (2.747, 16.397)
Self efficacy to adhere	12.527 (8.459, 18.551)	4.711 (2.062, 10.761)
Acceptance of HIV status	5.687 (3.989, 8.106)	4.727 (1.960, 11.403)
Simply forget	0.160 (0.111, 0.230)	0.080 (0.033, 0.197)
Distance to travel too long	0.240 (0.170, 0.340)	0.264 (0.111, 0.632)
*Education level	0.986 (0.898, 1.084)	1.430 (1.108, 1.844)
Age group 1 (18—30; Reference group)		
Age group 2 (31—44)	5.765 (3.554, 9.352)	5.119 (2.159, 12.14)
Age group 3 (45 or more)	0.880 (0.492, 1.575)	1.077 (0.388, 2.990)
Income group 1 (≤RM 1,500; Reference group)		
Income group 2 (RM 1,501—2,500)	3.109 (1.620, 5.192)	6.139 (2.289, 16.465)
Income group 3 (RM 2,501—10,000)	4.088 (2.151, 7.152)	9.993 (3.175, 31.454)

Self-efficacy to adhere = Self-efficiency to take & adhere to medication

Distance to travel too long = Distance to hospital too long and costly

*Education = number of schooling (7 categories)

We found that adherence was less likely if the patient had diarrhoea (aOR=0.081; 95% CI 0.034-0.192), vomiting (aOR=0.131; 95% CI 0.058-0.294), simply forgot their medication (aOR=0.080; 95% CI 0.033, 0.197), used herbal medicine (aOR=0.227; 95% CI 0.103-0.501), used religious treatment (aOR=0.067; 95% CI 0.027-0.165) or had to travel too far to get their medication (aOR=0.264; 95% CI 0.111-0.632).

Adherence was more likely with the use of the alarm clock (aOR=6.712; 95% CI 2.747-16.397), if they accepted their HIV status (aOR=4.727; 95% CI 1.960-11.403), had self-efficacy (aOR=4.711; 95% CI 2.062-10.761); were older (aOR=5.119; 95% CI 2.159-12.14), had higher education (aOR=1.430; 1.108-1.844) and had higher income (aOR=9.993; 95% CI 3.175-31.454).

4. Discussion

In this study, diarrhoea and vomiting were side effects identified to be negatively associated with the adherence to HAART and would result in lower adherence. Similar results have been reported elsewhere and this is not easy to resolve as diarrhoea is prevalent in 30 -70% of HIV-infected patients (Sherman et al., 2000).

More worrying but potentially modifiable are the use of religious treatment and of traditional medicine as co-treatments in HIV infections, which have been shown here to reduce adherence to HAART (Nsimba, 2010; Owen-Smith et al., 2007). We think that healthcare providers need to make their patients understand that these religious or traditional

treatments cannot be used as substitutes for HIV infection.

About two-thirds (69.4%) of the study respondents stated that using a watch and/or an alarm clock would help them to remember the time of drug intake. The use of simple but evidently effective devices like these to increase adherence has been shown by Yao et. al., (2010). We found that the distance to the hospital was inversely related to adherence. We think policy makers need to consider making HAART more easily accessible to patients as this will obviously resolve this apparent barrier to adherence. Other researchers like Kgatlwane et. al., (2006); Adam et. al., (2003); and Laws et. al., (2000) have noted the significance of self-efficacy in HAART adherence to antiretroviral drugs. This is confirmed in our own study. Reasons for missing medications that included forgetfulness and long travel distance were found to be significantly related with non-adherence one of the self-reported adherence questionnaire; these reasons have a decreasing effect on the adherence to antiretroviral treatments (Wasti et al., 2012). According to similar studies, the most common reason for missing medication is forgetfulness (Barfod et al., 2006).

Limitations of this study include recall bias and social desirability bias (Shi et al., 2010). Recall bias was minimized by ensuring proper definition and articulation of the research question and improving the quality of the questionnaire. Social desirability bias was minimized by engaging a research assistant who was not directly involved in the HIV clinic to collect the data.

5. Conclusion

Healthcare providers should treat adverse effects as effectively as possible, discourage the use of alternative treatments, provide counselling, encourage the use of the alarm clock and consider providing HAART closer to the patient's home to improve adherence.

Acknowledgment:

This study was fully supported by University Malaya (UM) Research Grant (UMRG006/09HTM) and STeMM Programme UM/MOHE High Impact Research Grant (E000010-20001).

Corresponding Author:

Dr. Umar Yagoub
Department of Social and Preventive Medicine
Faculty of Medicine, University of Malaya
Lembah Pantai, 50603 Kuala Lumpur., Malaysia
E-mail: mohammedumar2001@yahoo.com
Tel: + 966-554932680. Fax: + 966-73217443

References

1. Stirling G, Wilsey B. Empirical relationships between species richness, evenness and proportional diversity. *Am Nat* 2001;158(3):286-99.
2. Adam, B.D., Maticka-Tyndale, E., & Cohen, J.J. Adherence practices among people living with HIV. *AIDS care*, 2003; 15(2), 263-274.
3. Barfod, TS, Sørensen, H.T., Nielsen, H., Rodkjær, L., & Obel, N. 'Simply forgot' is the most frequently stated reason for missed doses of HAART irrespective of degree of adherence. *HIV medicine*, 2006; 7(5), 285-290.
4. Chesney, M. A. Factors affecting adherence to antiretroviral therapy. *Clinical Infectious Diseases*, 2000; 30, S171-S176.
5. Chesney, M. A., Ickovics, J. R., Chambers, D. B., Gifford, A. L., Neidig, J., Zwickl, B., Wu, A. W., Committee, P. C., & Group, Awgoftheooftheaact. Self-reported adherence to antiretroviral medications among participants in HIV clinical trials: the AACTG adherence instruments. *AIDS care*, 2000; 12(3), 255-266.
6. Chesney, M.A., Ickovics, JR, Chambers, DB, Gifford, AL, Neidig, J., Zwickl, B., Wu, AW. Committee, patient care, & group, adherence working group of the outcomes committee of the adult and AIDS clinical trials. Self-reported adherence to antiretroviral medications among participants in HIV clinical trials: the AACTG adherence instruments. *AIDS care*, 2000; 12(3), 255-266.
7. Do, N.T., Phiri, K., Bussmann, H., Gaolathe, T., Marlink, R.G., & Wester, C.W. Psychosocial factors affecting medication adherence among HIV-1 infected adults receiving combination antiretroviral therapy (cART) in Botswana. *AIDS research and human retroviruses*, 2010; 26(6), 685-691.
8. Gross, R., Tierney, C., Andrade, A., Lalama, C., Rosenkrantz, S., Eshleman, S.H., Flanigan, T., Santana, J., Salomon, N., & Reisler, R. Modified directly observed antiretroviral therapy compared with self-administered therapy in treatment-naïve HIV-1-infected patients: a randomized trial. *Archives of internal medicine*, 2009; 169(13), 1224.
9. Kgatlwane, J., Action, B.E.D., Ogenyi, R., Ekezie, C., Madaki, H.N., & Moyo, S. Factors that facilitate or constrain adherence to antiretroviral therapy among adults at four public health facilities in Botswana: a pre-intervention study. From access to adherence: the challenges of antiretroviral treatment, 2006.
10. Laws, M.B., Wilson, I.B., Bowser, D.M., & Kerr, S.E. Taking antiretroviral therapy for HIV infection: learning from patients' stories. *Journal of general internal medicine*, 2000; 15(12), 848-858.
11. Levine, A.J., Hinkin, C.H., Marion, S., Keuning, A., Castellon, S.A., Lam, M.M., Robinet, M., Longshore, D., Newton, T., & Myers, H. Adherence to antiretroviral medications in HIV: Differences in data collected via self-report and electronic monitoring. *Health Psychology*, 2006; 25(3), 329.
12. Maqutu, D., Zewotir, T., North, D., Naidoo, K., & Grobler, A. Factors affecting first-month adherence to antiretroviral therapy among HIV-positive adults in South Africa. *African Journal of AIDS Research*, 2010; 9(2), 117-124.
13. Mazlan, M., Schottenfeld, R.S., & Chawarski, M.C. New challenges and opportunities in managing substance abuse in Malaysia. *Drug and Alcohol Review*, 2006; 25(5), 473-478.
14. Nsimba, S.E.D. Barriers to ARV Adherence among HIV/AIDS Positive Persons taking Anti-Retroviral Therapy in Two Tanzanian Regions 8-12 Months after Program Initiation. *Journal of AIDS & Clinical Research*, 2010.
15. Owen-Smith, A., Diclemente, R., & Wingood, G. Complementary and alternative medicine use decreases adherence to HAART in HIV-positive women. *AIDS care*, 2007; 19(5), 589-593.
16. Peltzer, K., Friend-du Preez, N., Ramlagan, S., & Anderson, J. Antiretroviral treatment adherence among HIV patients in KwaZulu-Natal, South Africa. *BMC public health*, 2010; 10(1), 111.
17. Sherman, D.S., & Fish, D.N. Management of Protease Inhibitor—Associated Diarrhea. *Clinical Infectious Diseases*, 2000; 30(6), 908-914.
18. Shi, L., Liu, J., Koleva, Y., Fonseca, V., Kalsekar, A., & Pawaskar, M. Concordance of adherence measurement using self-reported adherence questionnaires and medication monitoring devices. *Pharmacoeconomics*, 2010; 28(12), 1097-1107.
19. Wasti, S.P., Simkhada, P., Randall, J., Freeman, J.V., & van Teijlingen, E. Factors Influencing Adherence to Antiretroviral Treatment in Nepal: A Mixed-Methods Study. *PloS one*, 2012; 7(5), e35547.
20. Wolfe, D., Carrieri, M.P., & Shepard, D. Treatment and care for injecting drug users with HIV infection: a review of barriers and ways forward. *The Lancet*, 2010; 376(9738), 355-366.
21. Yao, P., Kpatcha, T., Agnon, B., Vincent, P., Innocent, G., & Etienne, K. Knowledge and adherence to antiretroviral therapy among adult people living with HIV/AIDS treated in the health care centers of the association "Espoir Vie Togo" in Togo, West Africa. *BMC Clinical Pharmacology*, 2010; 10.

1/26/2012

Demographic, Socio-Economic Factors and Physical Activity Affecting the Nutritional Status of Young Children Under Five Years

Thanaa. A. Elkholy^{*}; Naglaa, H. M. Hassanen and Rasha, M.SC.

Department of Clinical Nutrition, Faculty of Applied Medical Sciences
King Abdul-Aziz University, Jeddah, Saudi Arabia

^{*}telkholy@kau.edu.sa

Abstract: Background: Modern lifestyle extends the umbrella of social responsibility for provision of appropriate nutritionally balanced foods to children of all age groups in particular the children under 5 years of age of all socio-economic groups of civil society which starts from home leads to the health professionals at all health outlets, Nutritionists, Dieticians, schools and the food industry. This was a cross-sectional descriptive study performed to investigate the relation between demographic, Socio-Economic Factors and physical activity affecting the nutritional status of young children under five Years of Age. One hundred twenty one young children, anthropometric data were taken using standard methods. Physical activities and other socioeconomic family parameters were assessed using validated questionnaire from Kindergarten children's and young children mothers by direct contact or by telephone. Logistic regression analyses were performed to estimate the influence of various parameters. SPSS computer software ver.10 was used in data analysis. Results: This study revealed that the impact of family size on nutritional status of children was significantly different. Birth order was a highly significant factor in relation to nutritional status in WAZ and WHZ $P < 0.001$. High prevalence of underweight was in Low income children. There was correlation between BMI and anthropometric measures. The breastfed group was better than the other group regard nutritional indicators; HAZ the differences were significant $P < 0.05$. A significant different by duration of breast-feeding in months $P < 0.01$. A significantly different exercising in WAZ Score $P \leq 0.05$, HAZ Score $P \leq 0.01$ and WH Z-Score $P < 0.001$. When the number of hours watching TV increased, the nutrition status gets worse ($\pm 2SD$ & $> + 2SD$).

[Thanaa. A. Elkholy; Naglaa, H. M. Hassanen and Rasha, M.SC. **Demographic, Socio-Economic Factors and Physical Activity Affecting the Nutritional Status of Young Children Under Five Years.** *Life Sci J* 2012;9(4):3604-3614]. (ISSN: 1097-8135). <http://www.lifesciencesite.com>. 534

Keywords: Socio-Economic Factors - physical activity- Nutritional Status - Children- Under five - Anthropometric

1. Introduction

The young children designed, for a child between infancy and school age, usually one three to five years of age (Grant, 1984).

It is well recognized that preschool children are a nutritionally vulnerable segment of population, also very susceptible to morbidity due to infections (Prema and Gopalan; 2009).

Nutrition of preschool child is of paramount importance, because the foundation for life time health, strength and intellectual vitality is laid during that period (Calliara; 1989).

In early childhood, adequate dietary intake is important for growth and development and to prevent nutrient-related deficiencies and toxicities, but excess dietary intake is linked to obesity (Ernst and Obarzanek; 2010). Prevalence of excessive body weight and obesity among children is increasing in many countries (Ogden *et al.*, 2002; Yngve *et al.*, 2008 and Perveen, *et al.*, 2010). It is believed that one of the two most important reasons for this increase is insufficient physical activity of children (Dietz; 1985, and Dennison *et al.*, 2002) and.

Developing healthy diet and physical activity patterns early in life is essential so that these practices follow into adulthood, which may prevent obesity, type 2 diabetes, and other chronic diseases (Tara *et al.*, 2010).

Adequate dietary intake and nutritional status among children are important for their own growth, development and function, and there is now increasing evidence that childhood nutrition also influences adult health. Thus, childhood diet needs to be taken seriously in order to improve a nation's health as well as producing bright and active children (Tomkins; 2001).

Growth assessment best defines the health and nutritional status of children, because disturbances in health and nutrition, regardless of their etiology, invariably affect child growth and hence provide an indirect measurement of the quality of life of an entire population (Onis *et al.*, 1993).

The growth and mental developments are indicators of good health and nutrition (WHO; 1995). The accurate assessment of the physical growth and development of children is a subject that gains the

interest of pediatricians and public health officers (**Tanner; 1966**). There is a worldwide variation in size and shape between children belonging to different populations of mankind (**Maysoon et al., 2004**).

Breastfeeding is considered as the first four strategies promoted by UNICEF for improving infant and child survival as reported by (**Grant, 1984**). This may enhance child survival up to 3 years of age even in undernourished children (**Brined et al., 1988**).

Malnutrition is still a major public health problem over large areas of the world, especially developing countries and particularly amongst low socio-economic groups (**Samai et al; 2009**). Malnutrition of pre-school children was documented to depressed growth, impaired intellectual development and altered behavioral responsiveness (**Birch, 1972; Read, 1973**).

Previous studies have observed that several diet and physical activity behaviors may be related to overweight in children including low fruit and vegetable intake, high sweetened beverage consumption, low levels of physical activity, and watching television more than two hours per day (**Adams; 2004**). previous findings, was developed for preschool aged children and their families that focused on four nutrition and physical activity behavior goals: increasing fruit and vegetable intake, decreasing sweetened beverage and sugar intake, increasing physical activity, and decreasing television watching (**Tara et al., 2010**). The purpose of this paper therefore was to explore basic and underlying factors determining the nutritional status of young children in KSA Jeddah City.

Subjects and Methods

Subject and setting:

A cross-sectional descriptive study was conducted on one hundred and twenty one Saudi male children aged 24- 60 months were chosen by a systemic random method, recruited from two kindergartens in KSA Jeddah city , all children were in kindergartens and their houses. Data collected by questionnaire from Kindergarten children's and preschool child mothers by direct contact or by telephone.

Methods:

The data collection initiated in October 2010 and complete in March 2011. All the studied children were subjected to the following criteria.

Demographic, socio-economic aspects

Standard questionnaires were designed to cover the majors' variables to demographic and socio-economic aspects.

After pre-testing and justifying the questionnaires was translated in to Arabic and applied in kindergartens and preschool child mother. The questionnaire contains several sections; the first is household schedule which included questions on basic demographic and socio-economic characteristics of the households. This section constitutes the essential part of the questionnaire which collects data on individual characteristics as to : age, educational status, occupational and employment status, marital status and finally questions on fertility in terms of number of children ever born and number of children alive.

The children were interviewed by the investigator; either in kindergartens or in their houses, to filling the detailed questionnaire from the mothers to collect information on the family socio-demographic characteristics and including information about number of children in the family, the rank of the child in siblings, educational level and employment of the parents.

Anthropometric measurements.

The weight and height of the children were assessed. Height was measured by a meter. The children were standing without shoes on a flat surface with feet parallel and heel together, and the head, back and heels in contact with the vertical board. The height was recorded to the nearest 0.1 cm (**WHO, 1995**).

Weight of children was determined by using an electronic scale (Piscover, Poland) and was recorded to the nearest 0.1 kg. The children were weighed with light indoor clothing and without shoes (**WHO, 1995**).

Anthropometric indices are combinations of measurements. They are essential for the interpretation of measurements. In children, the four most commonly used indices are weight-for-height, height-for-age, weight-for-age and BMI-for-age.

The anthropometric indices can be expressed in terms of Z-scores to compare a child or group of children with a reference population to assess their growth (**WHO, 1995**).

To assess the nutritional status of individual children, WHO recommends the use of Z-score indicators of weight-for-age (WAZ) (under-weight), height-for-age (HAZ) (stunting) and weight-for-height (WHZ) (wasting). To compute the anthropometric indices, information on each individual's gender, age, weight, and height are needed. WHZ and HAZ are the most commonly used indices for determining nutritional status (WHO, 2007).

The dependent variables for this study were the three anthropometric measurements:

Height-for-age (H/A), which indicates the level of stunting, weight-for-age (W/A), this indicates the level of underweight, and weight-for-height (W/H) which indicates the level of wasting. The independent variables were: education of the mother, family income, and breastfeeding, number of children under three in the family, parents' occupation and marital status of parents. Reference standards used were those of the National Center for Health Statistics (NCHS). Each of the three nutritional status indicators is expressed in standard deviation units (z-scores) from the median of this reference population (UNSCN, 2004).

Data about the Child

Gender, Birth date, Weight, Child orders, twinning (single or multiple births), Pattern of feeding at times of questionnaire either breast feeding, formula feeding and mixed food. The mothers of children above 2 years were asked about the feeding pattern through the 1st year, besides their actual feeding at the moment of the interview.

Education of the mother and father

The state of education was scored according to the following classification: Illiterate (not educated at all), Primary educational certificate, Preparatory educational certificate, Secondary educational certificate, University educational certificate.

Occupation of the mother and father

The occupation of the mother and father was assessed according to the following classification: No

occupation, unskilled worker, skilled worker, Semi – Professional and Professional.

Ethical Considerations

Permission was attained from the relevant kindergartens authorities; the kindergarten directors, and their staff.

Statistical analysis: has been achieved by using SPSS program SPSS Version 10 (1998)

The qualitative data were presented in the form of number and percentage. Chi-square was used as a test of significance for qualitative data. The quantities data were presented in the form of mean, standard deviation and range. One way ANOVA and student T test was used to compare quantities data and Pearson's correlation coefficient (r) has been also applied in this study between two quantities variables. Significance was considered when P value ≤ 0.05 . Insignificance was considered when P value > 0.05 .

3. Results

One hundred and twenty one Saudi children aged 24- 60 months were chosen by a systemic random method recruited from two kindergartens in KSA Jeddah city. Descriptive of Nutrition Status of Studied Sample of young age children, presented in **Table (1)** It was found that the mean \pm SD, minimum and maximum for WAZ were (-0.3637 \pm 1.328), (-3.81), (2.95) respectively; while for HAZ the mean \pm SD (-0.9597 \pm 2.0169), the minimum (-10.39) and maximum (3.8). Also, the mean \pm SD, minimum and maximum for WHZ were (0.1896 \pm 2.0725), (-5.47) and (4.93) respectively.

Table (1): Distribution and (Mean \pm SD) of Nutrition Status Studied Sample of young Children

Anthropometry measurements	No.	%	Nutritional Status	(mean \pm SD)	Min	Max
WAZ	10	8.3	Underweight	-0.3637 \pm 1.328	-3.81	2.95
	107	88.4	Normal			
	4	3.3	Overweight			
HAZ	23	19.0	Stunted	-0.9597 \pm 2.0169	-10.39	3.8
	94	77.7	Normal			
	4	3.3	Tall			
WHZ	15	12.4	Wasted	0.1896 \pm 2.0725	-5.47	4.93
	83	68.6	Normal			
	23	19.0	Overweight			
Total	121	100.0				

The same table shows that according to Weight /Age 88.4 % were normal, 8.3% were underweight and 3.3% were overweight. According to Height / Age (77.7 %) were normal, 19.0 % were stunted and 3.3 % were tall. According to Weight/Height (68.6%) were normal, 12.4 % were wasted and 19.0 % were overweight.

Table (2) shows the distribution of children by family size and nutritional status .Family size in this study seems to be one of the most effective factors on the nutritional status of the children.

The highest mean of underweight was found in family size more than 7 persons, while the highest mean of stunting children was found in family size

more than 6 persons while the lowest mean of normal nutritional status was shown in the least family size (5.57 persons). The highest mean of wasting children came from big families of size (6.6 persons). There was a significant association between nutritional status and family size in the nutritional indicator WAZ at $P < 0.01$.

As can be seen in **table (2)**, the (Mean \pm SD) of birth order of the study children by nutritional status. The analysis of the results revealed that the high means of underweight, stunting and wasting ($< -2SD$) was found among the group of high birth order. The reverse of that was shown in the normal nutritional

status ($\pm 2SD$). In summary the (underweight, stunting and wasting) was high among high birth order children and normal among low birth orders. Birth order was a highly significant factor in relation to nutritional status in WAZ and WHZ at $P < 0.001$.

Also **table (2)** presented (Mean \pm SD) of income of the study preschool children by nutritional status. The analysis of the results revealed that the low means of income appears in the stunting group ($< -2SD$). While the high mean of income was shown in the normal nutritional status ($\pm 2SD$). Income was significant factor in relation to nutritional status

Table (2): (Mean \pm SD) of Family Size, birth order and Income of the study children by nutritional status

Indicator	Family Size	Z-Scores				Total	F-value P
		$< -2SD$	$\pm 2SD$	$> +2SD$			
WAZ	No.	10	107	4	121	6.28	
	Mean	7.70	5.57	5.0	5.73	0.003**	
	SD	2.5	± 1.80	1.82	1.95		
HAZ	No.	23	94	4	121	1.47	
	Mean	6.35	5.57	5.75	5.73	NS	
	SD	2.33	± 1.83	1.89	1.95		
WHZ	No.	15	83	23	121	1.82	
	Mean	6.60	5.57	5.74	5.73	NS	
	SD	2.41	± 1.85	1.89	1.95		
Indicator	Birth Order						
WAZ	No.	10	107	4	121	9.75	
	Mean	6.90	3.80	4.50	4.08	0.000***	
	SD	2.02	± 2.12	2.65	2.28		
HAZ	No.	23	94	4	121	0.257	
	Mean	4.39	4.00	4.00	4.08	NS	
	SD	2.68	± 2.17	2.94	2.28		
WHZ	No.	15	83	23	121	18.67	
	Mean	7.00	3.57	4.04	4.08	0.000***	
	SD	1.89	± 1.92	2.34	2.28		
Indicator	Income(RS)						
WAZ	No.	10	107	4	121	0.193	
	Mean	5100	5205.61	4500	5173.55	NS	
	SD	2282.78	± 2239.18	2886.75	2246.03		
HAZ	No.	23	94	4	121	4.282	
	Mean	4043.48	5393.62	6500	5173.55	0.016*	
	SD	2225.44	± 2205.65	1000	2246.03		
WHZ	No.	15	83	23	121	7.664	
	Mean	4866.67	5638.55	3695.65	5173.55	0.001**	
	SD	2386.47	± 2069.39	2183.29	2246.03		

NS: Not Significant; * $P < 0.05$; ** $P < 0.01$; *** $P < 0.001$

Table (3) shows the anthropometrics indices of children by breastfeeding. It is apparent that the breastfed group was better than the other group regard nutritional indicators; HAZ. However, the differences were significant $P < 0.05$.

Mean \pm SD of breastfeeding duration of the study children by the anthropometrics indices WAZ,

HAZ, and WHZ presented in the same table. It is apparent that the normal nutritional status ($\pm 2SD$) improved with increase of (mean \pm SD) duration of breast-feeding. Nutritional status (In WAZ, HAZ and WH Z-Score) of children was significantly different by duration of breast-feeding $P < 0.01$.

Table (3): Distribution of the study children by nutritional status and Breast-feeding and Breastfeeding duration

Indicator	Breast-feeding	Z-Scores								χ^2 P
		< - 2SD		±2SD		> + 2SD		Total		
		No.	%	No.	%	No.	%	No.	%	
WAZ	Yes	10	9.3	94	87.0	4	3.7	108	100.0	1.91 NS
	No	0	0.0	13	100.0	0	0.0	13	100.0	
	Total	10	8.3	107	88.4	4	3.3	121	100.0	
HAZ	Yes	21	19.4	85	78.7	2	1.9	108	100.0	6.66 0.04*
	No	2	15.4	9	69.2	2	15.4	13	100.0	
	Total	23	19.0	94	77.7	4	3.3	121	100.0	
WHZ	Yes	14	13.0	74	68.5	20	18.523.1	108	100.0	0.38 NS
	No	1	7.7	9	69.2	3		13	100.0	
	Total	15	12.4	83	68.6	23	19.0	121	100.0	

Indicator	Breastfeeding duration	Z-Scores					F-value P	
		< - 2SD		±2SD	> + 2SD	Total		
		No.	Mean	SD	Mean	SD		Mean
WAZ	No.	10			94	4	108¶	4.98
	Mean	5.70		13.57	13.25	12.83		0.009**
	SD	4.88		±7.7	7.89	7.78		
HAZ	No.	21			85	2	108¶	5.69
	Mean	8.43		14.08	6.0	12.83		0.004**
	SD	4.93		±7.98	1.41	7.78		
WHZ	No.	14			74	20	108¶	6.34
	Mean	7.14		14.39	11.05	12.83		0.003**
	SD	6.26		±7.79	6.58	7.78		

¶ 108 No. of breastfeeding and the rest 13 not breastfeeding *p<0.05; **P< 0.01

Table(4) shows that the level of underweight, stunted and wasted were in children of low mean of BMI 13.3,15.78 and 14.85 respectively as compared to well nutritional status of moderate mean of BMI 16.3,16.06 and 16.02 respectively. Nutritional status (In WAZ and HAZ Z-Score) of children was significantly different by BMI P< 0.01 and P< 0.05 but no statistically significant association was observed in Nutritional status (In WHZ Z-Score).

As can be seen in **table (4)** the same table the BMI was highly significant and positively correlated to the WHZ and WAZ and negatively correlated to the HAZ.

From **Figure (1)** It was found a negative significant correlation between BMI and HAZ in

preschool children r = - 0.635 negative moderate correlation.

Table (5) shows that the nutritional status (±2SD) improved with increase % of Exercising. Nutritional status of children was significantly different by Exercising in WAZ, HAZ and WH Z-Score. Also the table shows the anthropometrics indices of children by (mean ±SD) of the number of hours watching TV. The association between nutritional statuses is indicated by WAZ, HAZ & WHZ and the number of hours watching TV. When the number of hours watch TV increased the nutrition status gets worse.

Table (4): (Mean ± SD) and Pearson Correlation of BMI of the study children by nutritional status

Indicator	BMI	Z-Scores				F-value P	Pearson Correlation	Sig.
		< - 2SD	±2SD	> + 2SD	Total			
WAZ	No.	10	107	4	121	4.901	0.454	0.000***
	Mean	13.30	16.3	20.68	16.2	0.009**		
	SD	2.56	±4.26	1.27	4.24			
HAZ	No.	23	94	4	121	3.724	- 0.635	0.000***
	Mean	15.78	16.06	21.73	16.2	0.027*		
	SD	3.07	±3.9	11.63	4.24			
WHZ	No.	15	83	23	121	2.35	0.242	0.008**
	Mean	14.85	16.02	17.71	16.2	NS		
	SD	7.08	±3.73	3.22	4.24			

*P< 0.05; **P<0.01; **Correlation is significant at the 0.01 level; ***Correlation is significant at the 0.001 level

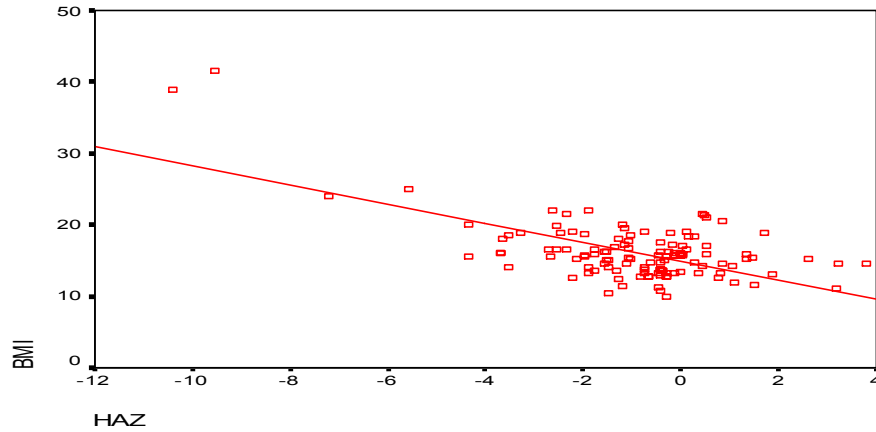

Figure (1): Correlation between BMI and HAZ of preschool children

4. Discussion

The present study reports on the level of nutrition status and the impact of some socioeconomic and demographic characteristics of households on the nutritional status of children under-five years of age in Jeddah KSA. One hundred twenty one households and mothers of young children representing the tow kindergarten in Jeddah participated in the study; hence the study may be regarded as a reasonable reflection of the nutritional status of children less than five years. A number of similar studies have been conducted in various parts of the world (Gobotswang, 1998; Maria Nnyepi; 2006; Timothy

and Richard, 2008; Vipin Chandran. , 2009 and Maria, *et al.*, 2011).

The questionnaire used in the present study was valid and reliable tool covered demographic information, breastfeeding practices, socio-cultural and economic factors and anthropometric data. Measuring the correlation of nutritional status for preschool children, physical activity and the duration of breast-feeding in month and television viewing habits in the study group. Although more objective measurements may be recommended, questionnaires can be good instruments for measuring the perceived environment in larger samples of young children.

Table (5): Distribution of the Exercising and (Mean ± SD) of the number of hours watching TV of the study children by nutritional status

Indicator	Exercising	Z-Scores								χ^2 P
		< -2SD		±2SD		> +2SD		Total		
		No.	%	No.	%	No.	%	No.	%	
WAZ	No	9	11.5	65	83.3	4	5.1	78	100.0	5.69 0.05*
	Yes	1	2.3	42	97.7	0	0.0	43	100.0	
	Total	10	8.3	107	88.4	4	3.3	121	100.0	
HAZ	No	22	28.2	53	67.9	3	3.8	78	100.0	12.64 0.002**
	Yes	1	2.3	41	95.3	1	2.3	43	100.0	
	Total	23	19.0	94	77.7	4	3.3	121	100.0	
WHZ	No	14	17.9	41	52.6	23	29.5	78	100.0	26.36 0.000***
	Yes	1	2.3	42	97.7	0	0.0	43	100.0	
	Total	15	12.4	83	68.6	23	19.0	121	100.0	
Indicator	The number of hours watching TV	Z-Scores					F-value	P		
		< -2SD	±2SD	> +2SD	Total					
WAZ	No.	10	107	4	121	0.472 NS				
	Mean	3.70	3.93	5.0	3.95					
	SD	2.31	2.29	3.16	2.31					
HAZ	No.	23	94	4	121	1.056 NS				
	Mean	3.52	4.0	5.25	3.95					
	SD	1.62	2.44	2.22	2.31					
WHZ	No.	15	83	23	121	0.125 NS				
	Mean	4.13	3.88	4.09	3.95					
	SD	3.02	2.12	2.52	2.31					

*P≤0.05; **P<0.01; ***P<0.001.

Socioeconomic Characteristics:

A challenge in estimation of birth order and family size effects is that birth order relates to family size. Theory suggests a tradeoff between child quantity and 'quality'. Family size might adversely affect the production of child quality within a family (Alison and Hiau; 2005). The present study reveals impact of family size on the nutritional status of children as present in table (2); the study did not demonstrate significant differences; but only in the nutritional indicator WAZ the significant was at $P < 0.003$. Other study by (Alison and Hiau, 2005) which use unique retrospective family background data from the 2003 British Household Panel Survey find that children from larger families have lower levels of education and that there is in addition a separate negative birth order effect. In contrast to (Black *et al.*, 2005), the family size effect does not vanish once we control for birth order. Our study revealed that birth order was a significant factor in relation to nutritional status in WAZ and WHZ $P < 0.001$ as shown in Table (2) which represent the (Mean \pm SD) of birth order of the study preschool children by nutritional status. The analysis of the results revealed that the high means of underweight, stunting and wasting ($< -2SD$) was found among the group of high birth order. The reverse of that was shown in the normal nutritional status ($\pm 2SD$) the present study is agreement with study by (Vipin; 2009)) which found the association between stunting, wasting and birth order was found to be significant at 0.05 levels. These findings reveals that a birth order of three or more show a birth interval of less than 24 months which is unhealthy for the mother.

Household economic status is positively related with child stunting in our group study. Finding of this study showed that compared with children residing in medium/higher economic status households. The analysis of the results revealed that the low means of income appears in the stunting group ($< -2SD$). While the high mean of income was shown in the normal nutritional status ($\pm 2SD$). Income was significant factor in relation to nutritional status in HAZ and WHZ at $P < 0.05$ and $P < 0.01$ respectively. Our results are agreement with study in Addis Ababa, Health and Nutrition Research Institute Ethiopia by (Girma *et al.*, 2002) which indicates the association of household economic status with household food security that is a prerequisite for access to adequate dietary intake for all members of the household in general and for young children in particular. Small-scale studies (Getaneh *et al.*, 1998) and (Yimer, 2000) undertaken in Ethiopia have also shown the importance of household economic status to improve stunting in children.

Breast Feeding

It has been proposed that breastfeeding promotion might be an effective way to prevent the development of obesity (Gillman; 2002).

The available evidence suggests that breastfeeding may have long-term benefits. Subjects who had been breastfed were found to have a lower mean blood pressure and lower total cholesterol, and showed higher performance in intelligence tests. Furthermore, the prevalence of overweight/ obesity and type-2 diabetes was lower among breastfed subjects (WHO, 2007). Concerning obesity, whereas (Summer, 2005) reported that combined dietary education and physical activity interventions were not effective in reducing childhood obesity and overweight, but (Bernardo *et al.*, 2007) noticed that breastfeeding was associated with a 22% reduction in the prevalence of overweight/obesity.

The present study depicted the correlation of anthropometrics indices of young children by breastfeeding which shown in table (3). It is apparent that the breastfed group was better than the other group, regard nutritional indicators; HAZ. However, the differences between groups were significant at $P < 0.05$. The protective effects of breastfeeding on children's nutritional status observed in this study suggest that breastfeeding is an important part of child care. However, there is need to educate mothers on safe breastfeeding and timely introduction of complementary foods because poor breastfeeding practices such as prolonged breastfeeding or failure to introduce adequate complementary foods as recommended places children at risk for stunting or underweight (Madzingira, 1995 & Fawzi, 1998)

Also we are showing in the same table that Mean \pm SD of breastfeeding duration (in months) of the study preschool children by the anthropometrics indices WAZ, HAZ, and WHZ. It is apparent that the nutritional status ($\pm 2SD$) improved with increase of (mean \pm SD) duration of breast-feeding in months. Nutritional status (In WAZ, HAZ and WH Z-Score) of children was significantly different by duration of breast-feeding in months $P < 0.01$. The same results showed by (Roy; 2000 and, Tewari *et al.*, 2005). That preschool children of the Shabar tribal community in Orissa were suffering from underweight (< -2 SD weight for age), which is an essential and rapid indicator to assess nutritional status in children as well as under nutrition (< -2.00 SD MUAC for age).

WHO (2001) considered that exclusive breast feeding for the first 6 months was the most appropriate infant feeding practice but in most of the studied children breast milk was initiated after 24 hours of birth and exclusive breastfeeding stopped before completion of 6 months of age. Therefore, these may be the major causes for high prevalence of

malnutrition among preschool children. Exclusive breastfeeding for less than 6 months may be a significant risk factor for high prevalence of underweight among Shabar preschool children. It is felt that there is an urgent need to inform women about the importance of early and extended breastfeeding among the Jeddah community.

Several possible biological mechanisms for a protective effect of breastfeeding against overweight and obesity have been proposed. Differences in protein intake and energy metabolism may be one of the biological mechanisms linking breastfeeding to later obesity. Lower protein intake and reduced energy metabolism were reported among breastfed infants (**Whitehead; 1995**).

Rolland-Cachera et al. (1995) observed that higher protein intakes in early life regardless of type of feeding was associated with an increased risk of later obesity. Another possibility is that breastfed and formula-fed infants have different hormonal responses to feeding, with formula feeding leading to a greater insulin response resulting in fat deposition and increased number of adiposities (**Lucas; 1980**). Finally, limited evidence suggests that breastfed infants adapt more readily to new foods such as vegetables, thus reducing the caloric density of their subsequent diets (**Birch and Fisher; 1998**).

Anthropometrics Measurements

Anthropometry provides non-invasive, easy and cheap but yet valuable information on nutritional status. Anthropometric measures of most significance in children include: weight and height (**Smith and Brown; 1970, FAO/WHO; 1971, Waterlow; 1972 and Sudesh; 2000**). A well-nourished child is one whose weight and height measurements compare very well with the standard normal distribution of heights and weights of healthy children of the same age and sex (**Salah et al., 2006**). Our result as can seen in table (4) the level of underweight, stunted and wasted were in children of low mean of BMI 13.3,15.78 and 14.85 respectively as compared to well nutritional status of moderate mean of BMI 16.3,16.06 and 16.02 respectively. Our results are agreement with the results of (**Maria; 2006**) that show that malnutrition was prevalent, with 11.3 %, 13.7%, and 3.9 % of children estimated to be underweight, stunted, and wasted respectively. The prevalence of stunting and underweight was higher ($p < .05$).

As we can see in the same table, the nutritional status (In WAZ and HAZ Z-Score) of children was significantly different by BMI $P < 0.01$ and $P < 0.05$ but no statistically significant association was observed in nutritional status (In WHZ Z-Score). The same table shows that BMI was highly significant and

positively correlated to the WHZ and WAZ and negatively correlated to the HAZ.

From **Figure (1)** It was found a negative significant correlation between BMI and HAZ in preschool children $r = - 0.635$ negative moderate correlation.

Also according to Pearson Correlation our Study revealed that there was correlation between BMI and anthropometric measures. It was found a positive correlation between BMI and WHZ in preschool children $r = +0.454$, and Correlation is significant at the 0.001 level. A negative significant correlation between BMI and HAZ in preschool children $r = - 0.635$ negative moderate correlation significantly at the 0.001 level. But there was found a positive significant correlation between BMI and WAZ in preschool children $r = + 0.242$ positive weak correlation and this Correlation was significant at the 0.01 level.

Physical Activity:

Overweight and obesity are directly caused by a positive balance between food energy intake and energy expenditure over a prolonged period of time, which provides a basis for the large quantity of scientific research dedicated to these two factors. It is generally accepted that increased levels of obesity can be explained through increased food energy intake and sedentariness (**Deforche; 2005, and Vieno et al., 2005**) and Weight is a sensitive index for the evaluation of nutritional status of preschool children, particularly where their precise ages are known (**Samai Mohamed, et al., 2009**). Thus weight alone cannot be the most suitable index in the evaluation of the nutritional status of preschool children in Jeddah. Thus the current study was undertaken to determine the relative merits of anthropometric measurements commonly used in nutrition survey for the evaluation of the nutritional status of preschool children in the kindergarten.

However, it is important to point out that the results of some studies suggest that information regarding the cause effect relationship between physical activity and childhood obesity is lacking, and that not enough data is available to determine the quantity and types of physical activity required achieving and maintaining a healthy body weight. In addition, too little data is available to determine the time of day when moderate and intense physical activity should be performed in order to prevent or reduce obesity (**Rennie et al., 2005 and Wareham, et al., 2005**), but it has been accepted that regular, systematic participation in moderate and intense physical activity offers significant health benefits, including the prevention of obesity (**Predel and Tokarski; 2005**).

A study of the relationship between physical activity and childhood obesity revealed that children whose total physical activity amounted to less than one hour per day tended to be more obese than those who participated in physical activity for more than two hours every day, (Ekelund *et al.*, 2004). Other studies of physical activity tendencies have revealed that physical activity is higher among boys and among school children with greater economic resources, which indicates that lack of knowledge among poorer children leads to a more negligent attitude with regard to childhood obesity (Montgomery *et al.*, 2004 and MOF *et al.*, 2005). This is demonstrated by the present study test correlation in Table (5) which shows that the nutritional status at ($\pm 2SD$) improved with increase % of Exercising. Nutritional status of children was significantly different by Exercising in WAZ Score at $P \leq 0.05$, HAZ Score at $P \leq 0.01$ and WH Z-Score at $P < 0.001$.

Television watching and media use has been shown to be positively associated with BMI in children (Gortmaker *et al.*, 1996; Gortmaker; 1985; Kaur *et al.*, 2003; Dietz and Epstein *et al.*, 2008) the American Academy of Pediatrics recommends that children over two years should not watch more than two hours of television per day (American Academy of Pediatrics Committee; 2001). This is demonstrated by the data presented in our study shows that young children, which the number of hours watching TV increased the nutrition status gets worse ($\pm 2SD$ & $> + 2SD$) as shown in table (5) which revealed that the association between nutritional status as indicated by WAZ, HAZ & WHZ.

Conclusions

Improving dietary and lifestyle patterns and reducing obesity will require a sustained public health effort, which addresses not only individual behaviors but also the environmental context and conditions in which people live and make choices. Individual behavior change is difficult to achieve without addressing the context in which people make decisions.

Breastfeeding was found to reduce the occurrence of underweight among children. The study findings imply that efforts for redressing child undernutrition issues in Jeddah city should focus on factors associated with development outcomes such as maternal income, maternal education, and the creation of employment or economic engagements that do not compromise important child care practices such as breastfeeding.

Physical inactivity among Saudi children represents a growing public health challenge, and actions to control obesity and promote physical activity must begin now. It is very critical that

preventive strategies are implemented through schools and community-based programs, with involvement from health care providers, school teachers, community leaders, and policy makers, as well as parents.

It appears that poverty family size and housing conditions influenced the height and the health of this cohort. These findings are consistent with other evidence showing that childhood height is a marker for bio-physiological processes that can affect future health.

This finding underlines the need for properly conducted surveys to ensure accurate information about the nutritional status of children. Participatory approaches are particularly well suited for research work with young children.

Corresponding author

Thanaa. A. Elkholy

Department of Clinical Nutrition, Faculty of Applied Medical Sciences

King Abdul-Aziz University, Jeddah, Saudi Arabia

telkholy@kau.edu.sa

References

- Adams. A; Prince R, and Webert H. (2004): The Wisconsin Nutrition and Growth Study (WINGS), a participatory research project with three Wisconsin tribes. The Great Lakes EpiCenter News. pp. 1–3
- Alison L. Booth and Hiau Joo Kee (2005): Birth Order Matters: The Effect of Family Size and Birth Order on Educational Attainment IZA (Institute zur Zukunft der Arbeit) DPN0.1713.
- American Academy of Pediatrics (2001): Committee on Public Education. Children, adolescents, and television. *Pediatrics* 107:423–426. [PubMed: 1115848
- Bernardo L. Horta, Rajiv Bahl, José C. Martines and Cesar G. Victora, (2007): 1. Breast feeding. 2. Blood pressure. 3. Diabetes mellitus. 4. Cholesterol. 5. Obesity. ISBN 978 924 – 159523.
- Birch, H.G, (1972): Malnutrition, learning and intelligence. *Am. J. Publ.Health*, 62: 773.
- Birch LL and Fisher JO, (1998): Development of eating behaviors among children and adolescents. *Pediatrics*, 101(3 Part 2):539-49.
- Black, Sandra E, Paul J Devereux and Kjell G. Salvanes (2005): “The More the Merrier? The Effect of Family Size and Birth Order on Children’s Education”. *Quarterly Journal of Economics*, 120(2)..... 669-700
- Brined A, Wojtyniak B and Rowland M (1988): Breastfeeding, nutritional state and child survival in rural Bangladesh. *B.M.J.*, 296:879-882.
- Calliara M. (1989): Profile of an Indian Child. *Social Welfare*;36:33-4. (s).
- Deforche B, De Bourdeaudhuij I, Tanghe A, Deboode P, Hills AP and Bouckaert J (2005): Role of physical activity and eating behavior in weight control after

- treatment in severely obese children and adolescents. *Acta Paediatr.*; 94(4):464 - 70.
12. Dennison BA, Erb TA and Jenkins PL (2002): Television viewing and television in bedroom associated with overweight risk among low – income preschool children. *Pediatrics*; 109:1028 – 35.
 13. Dietz WH Jr and Gortmaker SL, (1985): Do we fatten our children at the television set? Obesity and television viewing in children and adolescents. *Pediatrics*; 75:807–812. PubMed: 387306]
 14. Ekelund U, Sardinha LB, Anderssen SA, Harro M, Franks PW, Brage S, Cooper AR, Andersen LB, Riddoch C and Froberg K, (2004): Associations between objectively assessed physical activity and indicators of body fatness in 9 to 10y old European children: a population - based study from 4 distinct regions in Europe (the European Youth Heart Study). *Am J Clin Nutr.*; 80(3):584 - 90.
 15. Epstein LH, Roemmich JN, and Robinson JL, (2008): A randomized trial of the effects of reducing television viewing and computer use on body mass index in young children. *Arch Pediatr Adolesc Med*; 162:239–245.
 16. Ernst ND and Obarzanek E, (2010). Child health and nutrition: Obesity and high blood cholesterol. *Prev Med.*; 23:427–436.
 17. FAO/WHO Expert Committee on malnutrition, (1971): WHO Technical Report., 477:34-70
 18. Fawzi WW, Herrera MG, Nestel P, El Amin A and KA Mohamed A (1998). longitudinal study of prolonged breastfeeding in relation to child undernutrition. *Int. J. Epidemiol.*; 27(2):255-60.
 19. Getaneh, T., A. Assefa, and, Z. Taddesse. (1998): Protein energy malnutrition in urban children: Prevalence and determinants. *Eth. Med. J.*, 36(3): 153-66
 20. Gillman MW, (2002): Breast-feeding and obesity. *The Journal of Pediatrics*, 141(6):749-50
 21. Girma, Woldemariam and Timotiows Genebo. (2002): Determinants of Nutritional Status of Women and Children in Ethiopia. Calverton, Maryland, USA: ORC Macro Page from 1 – 36
 22. Gobotswang K (1998): Determinants of the nutritional status of children in a rural African setting: the case of Chobe district, Botswana. *Fd. and Nutr. Bull.*, 19(1):42-45.
 23. Gortmaker S, Must A, Sobol A, Peterson K, Colditz G and Dietz W. (1996): Television viewing as a cause of increasing obesity among children in the United States, 1986-1990. *Arch Pediatr Adolesc Med.*; 150:356–62.
 24. Grant JP, (1984). The state of the world's children. Oxford University Press: Oxford. Calliara M. Profile of an Indian Child. *Social Welfare*, 36: 33 - 4.
 25. <http://www.yourdictionary.com/preschool> Webster's new world collage Dictionary Copyright © 2010 by Wiley Publishing, Inc., Cleveland, Ohio. Used by arrangement with John Wiley & Sons, Inc
 26. Kaur H, Choi WS, Mayo MS and Jo Harris K, (2003). Duration of television watching is associated with increased body mass index. *J Pediatr.* ,143:506–511.
 27. Lucas A, (1980): Breast vs. bottle: endocrine responses are different with formula feeding. *Lancet*, 1(8181):1267-9.
 28. Madzingira N (1995): Malnutrition in children under five in Zimbabwe: effect of socioeconomic factors and disease. *Soc. Biol.*; 42(3-4):239-46.
 29. Maria S. Nnyepi (2006): Dietary and Nutrition Screening for Children's in Botswana Seeking Curative Care in Health, 6 (2): **ISSN: 1684-5358 EISSN: 1684-5374**
 30. Maria Nnyepi, Kesitegile S M Gobotswang and Patrick Codjia (2011): Comparison of estimates of malnutrition in children aged 0–5 years between clinic-based nutrition surveillance and national surveys. *Journal of Public Health Policy* 32, 281-292 doi:10.1057/jphp.2011.32
 31. Maysoun M. Al-Amoud, Yagob Y. Al-Mazrou, Sirrag E. El-Gizouli, Tawfik A. Khoja and Khalid A. Al-Turki, (2004): *Saudi Med J* ;25 (11): 1679-1682
 32. MoF, Turner M, Krewski D and Mo FD (2005): Physical inactivity and socioeconomic status in Canadian adolescents. *Int J Adolesc Med Health*, 17(1):49 - 56
 33. Montgomery C, Reilly JJ, Jackson DM, Kelly LA, Slater C, Paton JY and Grant S, (2004): Relation between physical activity and energy expenditure in a representative sample of young children. *Am J Clin Nutr*; 80(3):591 - 6.
 34. Ogden C, Flegal K, Carroll M and Johnson C, (2002): Prevalence and trends in overweight among US children and adolescents, *JAMA*; 288(14):1728-32.
 35. Onis, M, Monteiro C, Akre J and Clugston, G (1993). The worldwide magnitude of protein-Energy malnutrition: an overview from the WHO Global Database on child growth. *Bulletin of the World Health Organization*, 71: 703-712.
 36. Perveen Liaqat, Nazish Zulfiqar, Hajra Ahmed and ASMA afreen (2010): Emerging Dietary Patterns from Daily Food Intake Patterns of Young Children under Five, *Pakistan JOURNAL OF Nutrition*, 9 (5):504-511.
 37. Predel HG and Tokarski W, (2005): Influence of physical activity on human health. *Bundesgesundheitsblatt Gesundheitsforschung Gesundheitsschutz*; 48 (8):833 - 40.
 38. Prema Ramachandran and Hema S. Gopa, (2009): Under nutrition & risk of infection in preschool children. *Indian J Med Res* 130, PP 579-583
 39. Read, M.S (1973). Malnutrition, hunger, and behavior. 2. hunger school feeding problems and behavior. *J. AM. Diet. Assoc.*, 63: 386.
 40. Rennie KL, Livingstone MB, Wells JC, McGloin A, Coward WA, Prentice AM and Jebb SA, (2005): Association of physical activity with body - composition indexes in children aged 6 - 8 y at varied risk of obesity. *Am J Clin Nutr.*; 82(1):13 - 20.
 41. Rolland-Cachera MF, Castetbon K, and Arnault N (1995): Influence of macronutrients on adiposity development: a follow up study of nutrition and growth from 10 months to 8 years of age. *International Journal of Obesity and Related Metabolic Disorders*, 19(8):573-8.105.

42. Roy NK, (2000). Use of mid upper arm circumference for evaluation of nutritional status of children and for identification of high-risk groups for malnutrition in rural Bangladesh. *J.Health Popul. Nutr*, 18.171-180
43. Samai Mohamed, Samai Hajah H, Bash-Taqi Donald A, Gage George N4 and Taqi Ahmed M, (2009): The Relationship between Nutritional Status and Anthropometric Measurements of Preschool Children in a Sierra Leonean Clay Factory Displaced Camp. *Sierra Leone Journal of Biomedical Research* 1 (1) 21-27,
44. Salah E.O. Mahgoub, Maria Nnyepi, and Theodore Bandeke (2006): Factors Affecting Prevalence of Malnutrition among Children Under Three Years of Age in Botswana Volume 6 No (1) ISSN1648 – 5378.
45. Smith DS and Brown ML, (1970): Anthropometry in preschool children in Hawaii. *Am J Clin Nutri.*, 23:7?
46. Statistical Package for Social Science (SPSS) Computer software, ver. 10. SPSS Company. Chi-square was used as a test of significance for qualitative data. The quantities data were presented in the form of mean, standard deviation and range. One way ANOVA and student T test London, UK 1998.
47. Sudesh J, Saroj B and Salil S, (2000): Nutritional status of rural pre-school children of Haryana state. *Indian J Pediatr.*, 67: 189-196.
48. Summer Bell CD, (2005): Interventions for preventing obesity in children. *Cochrane Database of Systematic Reviews*, (3): CD001871.
49. Tanner JM, Whitehouse RH, Takaishi M, (1966): Standards from birth to maturity for height and weight. Height velocity and weight velocity: British children, 1965 (part I), *Archives of Disease in Childhood*; 41: 454-471.
50. Tara L. Alexandra K. Jared B.Kate A. SuAnne M. and Ronald J, (2010): Dietary Intakes and Physical Activity among Preschool Aged Children living in Rural American Indian Communities prior to a Family-based Healthy Lifestyle Intervention. 110(7): 1049–1057. Tewari P, Shekhawat N and Choudhary S, (2005): Use of nutritional anthropometry and clinical examination in the assessment of nutritional status of children. *Man In India*. 85. 49-60.
51. Timothy J. Hatton and Richard M. Martin (2008): British Children in the 1930s Discussion paper Eries Forschungsinstitut Zur Zukunft der Arbeit Institute for the Study Labor January IZA DP No. 3314.
52. Tomkins A, (2001). Vitamin and mineral nutrition for the health and development of the children of Europe. *Public Health Nutrition*, 4 (1A): 91-99.
53. United Nations Sub-Committee on Nutrition (2004): Nutrition for Improved Outcomes 5th Report on the World Nutrition Situation: Marchpp52-54.
54. Vieno A, Santinello M and Martini MC, 2005. Epidemiology of overweight and obesity among Italian early adolescents: relation with physical activity and sedentary behaviour and *Epidemiol Psichiatr Soc*; 14(2):100 - 7.
55. Vipin Chandran. K.P (2009), Malnourished Indian children: The Post-reform scenario, in Dr. K.Gangadharan (ed.), *Paradigm shift in Health and Education in India*, Serials Publication New Delhi.
56. Wareham NJ, van Sluijs EM and Ekelund U, (2005): Physical activity and obesity prevention: a review of the current evidence. *Proc Nutr So*; 64 (2):229 - 47.
57. Waterlow JC, (1972): Classification and definition of protein-calorie malnutrition. *Med.J*:566-9
58. Whitehead RG, (1995): For how long is exclusive breastfeeding adequate to satisfy the dietary energy needs of the average young baby? *Pediatric Research*, 37(2):239-43.
59. World Health Organization, (1995): Physical Status: the use and interpretation of anthropometry. *World Health Organ Tech Rep Ser*; 854:273.
60. World Health Organization (WHO),(2001): Regional office for the Eastern Mediterranean: Overview of Child Health in Arab Countries.
61. World health organization, (2007): Evidence on the long-term effects of breastfeeding. http://whqlibdoc.who.int/publications/2007/9789241595230_eng.pdf.
62. World Health Organization (WHO)(2007): Influence of parental and socioeconomic factors on stunting in children under 5 years in Egypt Eastern Mediterranean Health Journal Volume 13 No. 6 November – December.
63. Yimer, G. (2000): Malnutrition among children in southern Ethiopia: Levels and risk factors *Ethiopian Journal of Health Development* 14(3):283-292.
64. Yngve A, De Bourdeaudhuij I, Wolf A, and Grjibovski A, Brug Jand Due P (2008): Differences in prevalence of overweight and stunting in 11 – year olds across Europe: The Pro Children Study. *Eur J Publ Health*; 18(2):126-30.

The Study of Woman's Attitude towards the Presence of the Husband's in the Labor Room during Childbirth

¹Neama Mohamed El-Magrabi and ²Nadia Abdallah Mohamed

¹Community Health Nursing, Faculty of Nursing, Assiut University

²Obstetrics & Gynecological Health Nursing, Faculty of Nursing, South Valley University
drnadia37@yahoo.com

Abstract: Husband's support during childbirth is a vital to a parturient woman's emotional well-being. This study aimed to identify the attitudes of wives' to the presence of their husband in the labor room during childbirth. This study was conducted at the outpatient antenatal care clinic, in Women Health Hospital, Assiut University, Egypt. The study consists of a quota sample of 200 women at the end of the third trimester of pregnancy who attended the out-patient antenatal clinic. A structured interview sheet was used to investigate the attitude of women regarding the husband's presence in the delivery room during childbirth. The results show that, 64.0% of women had positive attitude towards the presence of the husband in the delivery room. The attitude scores were significantly related to age, job, and education ($p < 0.01$). They reported that it will reduce mothers' anxiety and strengthen the bond between the husband and women and his baby as well. The study recommended to accept the presence of the husband in the labor room and providing training for the husbands about the skills needed to promote the active participation in the delivery. Also, encouraging hospital administrators to develop "a Performance Protocol" to guide staff on realizing the new policy of having a father in the delivery room.

[Neama Mohamed El-Magrabi and Nadia Abdallah Mohamed. **The Study of Woman's Attitude Towards the Presence of the Husband's in the Labor Room During.** *Life Sci J* 2012;9(4):3615-3620]. (ISSN: 1097-8135). <http://www.lifesciencesite.com>. 535

Keywords: Woman; Attitude; Husband; Labor; Room; Childbirth

1. Introduction

Pregnancy is accompanied by significant biological, physiological and psychological changes in women. Childbirth is a significant event in the lives of women and their families. It is a critical time in the human development that transforms women into mothers (Siriwan *et al.*, 2008). Most women have a positive attitude towards childbearing. However, anxiety at the onset of labor is accompanied by a significant increase in adrenaline levels and consequently longer delivery. The mother's stress and attitude and her catecholamine levels significantly affect uterine contractions, length of labor and the neonate's Apgar score (Sciarra, 1991).

Fifty years ago, very few fathers attended their children's births. Today 93% of fathers in western countries do so (Kiernan & Smith, 2003). National Health Service, (NHS), (2005) data showed that 98% of fathers attended the birth, 48% attended antenatal/parenting classes, 85% at least had one prenatal appointment, and 86% at least attended one ultrasound scan.

Fear of loneliness in the delivery room is common among women and the presence of husband, mother, or close friend is often suggested for pregnant women (Sweet, 1988). The presence of the husband in the delivery room is recommended to decrease stress that can facilitate the labor process

and delivery (Sciarra, 1991). The presence of the accompanying person decreases the intensity and prevalence rate of reactions to stimuli for the mother. Moreover, the active involvement of the husband, in the delivery can prepare the wife for the upcoming contraction (Hodnett, 1999).

Although various studies have investigated the presence of the husband during labor, this practice is still uncommon in some Islamic countries. In Western Society, there is clear understanding of the greater effect of a husband's attendance during childbirth which enables his wife to feel more secure and reduced the expected anxiety and pain of the labor process (Zadorozny, 1999 and Larkin, *et al.* 2009) Previous studies in Nepal have explored the experiences of husbands and wives separately following the birth of a baby where the husband was present at the birth. The husbands described their experiences positively, but confessed that they had overwhelmingly emotional feelings, Sapkota, *et al.* (2011 a & b).

Research has shown that when women in labor have a greater sense of stress, lack of security and anxiety. Husband's presence will help to reduce maternal anxiety and stress during childbirth (Sciarra, 1991 & Sweet, 1988) and ultimately leads to a more positive birth experience (Noack, 1976). Labor support from a birth companion has been found beneficial in reducing maternal distress, and is a

major step towards greater personal control (Sweet1988, Somers, 1999, IPWY, 2000a & Hodnett, 2011).

A study outcome in Denmark by Madsen *et al.* (2002) showed that 95% of the fathers attended delivery at the hospital and 98% of them do it because they wanted to. Seventy per cent also wish to stay overnight with the child and the mother at the hospital. Reports also showed increasing participation of fathers at the birth in lower-income countries. For example, in Ukraine, the man's attendance at the birth has increased during the past decade from 0% to 52% (United States Agency for International Development, 2005)

Significance of the study

Although various studies have investigated the presence of the husband during labor, this practice is still uncommon in Islamic countries. Therefore conducted that the study in Egypt the aim of this study was to identify the wife's attitude towards the presence of husband in the labor room during childbirth. And to determine their receptiveness to and the feasibility of introducing the practice into delivery rooms in Egypt.

Research questions

There is a positive relation between women's attitudes toward present of a husband during labor and their personal characteristic?

Aim of The study:

The aim of the present study was to identify the wife's attitude towards the presence of husband in the labor room during childbirth

2. Methodology:

A descriptive design was used in conducting the study. The study was carried out at the antenatal care clinic, Women Health Hospital, Assiut University, Egypt. This clinic starts at 9 a.m. and ends at 1 p.m. three days every week. This clinic was selected because it is attended by a large number of patients; it provides free services to the rural and urban women in Assiut Governorate and other near cities. A quota sample of 200 pregnant women who attended the outpatient antenatal clinic and met the inclusion criteria were recruited for the study. The inclusion criteria were: Women who have a normal pregnancy, normal labor, age between 20-37 years; and at the end of the third trimester of pregnancy (36-42weeks of gestation).

Tools of data collection:-

A structured interview sheet was developed to collect the relevant data. It consists of two parts: the first part was developed by the researchers, it was concerned with social-demographic data such as age, education, address, gestation age... etc. The second part was developed by ModarresNejad (2005). To be

used in Iran. The sheet consists of a five point Likert Scale that included 27 statements investigating Women's' attitude towards the presence of the husband in the delivery room during childbirth. The sheet contained positive and negative statements to allow for investigating the positive and negative attitude of mothers. Originally, the tool was used by, ModarresNejad (2005) to assess both women and husband's attitude. However, in the Upper Egypt it was almost impossible to get any feedback from the husband on the sheet, so the researcher used it only for women.

Scoring system:

The responses to the attitude –testing expressions were scored as follows: One point of complete disagreement to 5 points for complete agreement. The total score per person were between 27and -135. A cumulative score of 68-135 were considered "positive attitudes. When the woman scored less than 68 points it is considered negative attitude. The statement of positive attitudes were 1 - 13, 15, 19, 20, 22 and 23, while the negative attitude statements were 14, 16, 17, 18, 21, 24, 25, 24, 25, 26 and 27.

Field work:

The study started from October\ 2010-to the end of Feb 2011. The researchers introduced themselves to the eligible women and briefly explained the nature of the study. The researchers introduced the attitude –testing expressions questionnaire and the filling of the questionnaire took 15-25 minutes for each participant.

Administrative approval:

The necessary official permission was obtained from the Dean of Faculty of Nursing, Assiut University to proceed with the study.

The necessary official permission was obtained from the chairman of Women' Health Hospital, Assiut University, Egypt, to proceed with the study

A Pilot study

A Pilot study was conducted at 10% of the sample, who were from the study, to assess the clarity of the tools and estimate the time required for filling the sheet.

Ethical consideration:

A formal consent was obtained orally from women before being involved in the study. The nature and purpose of the study were explained. The researchers informed the women that there is no risk or cost for participation, and the participation is voluntary. Also, the women were assured that the confidentiality of information will be done and anonymity of each subject will be maintained.

Validity of content:

Although the tool was validated by the original author, the researchers gave a copy of the tool to six

of experts in the field two of the community health nursing, two of the Obstetric and gynecological nursing and two experts in the field of Psychiatric nursing to assess the content and face validity of the tool and its validity for Egyptian culture.

Statistical analysis:

Data were coded, analyzed and tabulated. Descriptive statistics (i.e. Frequencies and percentage were done using computer program SPSS version 16. The chi - square test was used to compare the differences in the distribution of frequencies. It is considered significant when $P < 0.05$.

3. Results

Table 1 illustrated that the mean age and standard deviation (SD) of the women was 25.86 ± 6.51 years, and 28.5% were working women. The women's educational status varied with more than 72% of them were illiterate, while 8.5 % were university graduates. The mean age of their husbands was 30.31 ± 6.37 years. Also, 46. % of the husband were illiterate, and 17% had only been university graduates.

Table 2 showed the mean attitude scores for the individual items on the questionnaire. It was found that a mean score of 3.98 ± 0.785 was obtained to the item "it is pleasurable since observing childbirth is one of the most important moments in life". Also, a mean score of 3.65 ± 0.631 was obtained to the item "it provides emotional support for the mother". In addition, a mean score of 3.52 ± 0.628 " was obtained to the item "it prepares the husband to accept his paternal responsibility", and 3.31 ± 0.598 was obtained to the item "it strengthens the couple's relationship". Likewise, 3.00 ± 0.833 reported that "the presence of the husband increases his sympathy and gratitude towards his wife".

However, a mean score of 1.66 ± 0.530 was obtained to the item clarified that "it is not helpful to the mother" and a mean score of 3.20 ± 0.812 was obtained to the item claiming that "it may lead to psychological disorders in the husband". Also, 2.88 ± 0.277 was obtained to the item reported that "it is unpleasant for the mother and is not tolerable for the husband".

Table 3 clarified that the majority (64.0%) of women had positive attitudes towards the presence of the husband in the delivery room and their attitudes was significantly correlated ($P < 0.001$).

Table 4 illustrated the relationship between the attitude of women and the statistically significant socio- demographic characteristics. As for age the table showed a negative relation ($P < 0.03$) where the younger the age the greater the positive relation (22.86 ± 6.51). The attitude scores were significantly

related to woman's job ($P < 0.02$) and education ($P < 0.001$).

Table (1): Demographic data of study group

Item	Descriptive	
	%	No
Age of mother		25.86 ± 6.51
Residence:		
Urban	37.5	75
Rural	62.5	125
Woman Education:		
Illiterate	72.0	144
Primary	4.0	8
Preparatory school	4.5	9
Secondary	11.0	22
University	8.5	17
Job:		
Housewife	71.5	143
Work outside the house	28.5	57
Mean Age of husband:		30.31 ± 6.37
Education of husband:		
Illiterate	46.0	92
Primary	13.5	27
Preparatory school	7.5	15
Secondary	15.5	31
University	17.5	35
Job of husband:		
Governmental job	10.0	20
Privet	86.0	172
Not work	4.0	88

Table (2): Scores for individual items of attitude to the husband's presence in the delivery room.

Item	Mean \pm SD
1. Is pleasurable since observing childbirth is one of the most important moments in life	3.98 ± 0.785
2. Provides emotional support to the mother.	3.65 ± 0.631
3. Provides the mother the opportunity to express her problems to a familiar person	2.56 ± 0.740
4. Increases the mother's self-confidence	3.17 ± 0.850
5. Increases the husband's sympathy and gratitude towards his wife.	3.00 ± 0.833
6. Allows the husband to share the pain of delivery with his wife.	2.78 ± 0.741
7. Prepares the husband to accept his paternal responsibility	3.52 ± 0.628
8. Has positive effects on the husband's	2.72 ± 0.896
9. Strengthens the couple's relationship	3.31 ± 0.598
10. Creates a feeling of pride in the husband	2.70 ± 0.782
11. Decreases the mother's anxiety	2.82 ± 0.381
12. Helps the mother bears labor pain	2.70 ± 0.372
13. Has a positive effect on father-child relationship	2.77 ± 0.799
14. Is not helpful to the mother	1.66 ± 0.530
15. Increases the husband's self-confidence	2.48 ± 0.757
16. May lead to psychological disorders in the husband	3.20 ± 0.812
17. Transfers the husband's anxiety to the mother	2.65 ± 0.737
18. Is not a good idea since the delivery room is not suitable for men	3.04 ± 0.420
19. Is calming for the husband	3.08 ± 0.368
20. Is calming for the mother	3.08 ± 0.591
21. Is unpleasant for the mother	2.88 ± 0.277
22-Is the husband's duty	2.88 ± 0.55422
23-Decreases the husband's anxiety	2.75 ± 0.40823
24. Is not tolerable for the husband	2.88 ± 0.631
25. Is against Egypt culture	3.35 ± 0.802
26. Is frightening in the case of a complicated delivery	2.72 ± 0.731
27. Is frightening for the husband	2.58 ± 0.567

Table (3): Percentage of attitude in study group

Item	Women's attitude	
	No	%
Positive attitude	64.0	128
Negative attitude	36.0	72

Table (4): Relationship between women's attitude & significant socio-demographic data

Item	Positive attitude n=128		Negative attitude n=72		P-value
	%	No	%	No	
1- Woman's Job:					P < 0.02*
Housewife	45.3	58	93.1	67	
Work outside The house	54.7	70	6.9	5	
2- Age	28.51± 6.37		28.51± 6.37		P < 0.03*
3- Education					P < 0.001**
Illiterate	68.8	88	56	56	
Primary	0.8	1	7	7	
Preparatory school	1.6	2	7	7	
Secondary	16.4	21	1	1	
University	12.4	16	1	1	

4. Discussion

Childbirth is a turning point in the family life. The presence of the husband in the delivery room can not only provide emotional support for the mother, but can also establish an earlier relationship between a father and his infant. The presence of the husband during labor and delivery can lead to a deeper relationship between the married couple and help the man to face and accept his responsibility as a father. Several studies show that the presence of the man in the labor room shortens the labor and reduces the epidural rate (Berry, 1988).

Overall, the present study showed that 64% of women had positive attitudes towards the husband's presence in the delivery room, where in Germany, ModarresNejad (2005) found that almost all couples had positive attitudes and intended to repeat the practice for any subsequent deliveries. This positive feeling of the majority of women reflects their need for security and support during this critical time of life.

In the current study, the highest reported attitude score was for the item "it is pleasurable since observing childbirth is one of the most important moments in life". Also rated high, where the beliefs that the husband's presence "provides emotional support to the mother and "provides the mother the opportunity to express her concerns to a familiar person" also, " it prepares the husband to accept his paternal responsibility", and a high percentage reported that "it strengthens the couple's relationship". Likewise, one of the highest attitude scores was for the item "presence of the husband Increases his sympathy and gratitude towards his wife". These findings reflect the woman's need for appreciation of her husband during this painful

experience, and his presence will increase the bond between him and his baby and between him and her as well.

These findings are supported by the findings of IPWY (2000 b) in the United Kingdom (UK), where women preferred their husbands to be with them during labor and delivery because they believed that it decreases their anxiety and loneliness and that their husbands wanted to be there to help as a matter of gratitude and sharing the responsibility. In the UK study, ModarresNejad (2005) found that men believed that mothers preferred to talk about their worries with somebody familiar to them and that, although the medical teams are experts in necessary care, they are not well known to the mothers. From the point of view of the women in the UK study, being able to speak to the husband was also one of the most important benefits of the husband's presence. In a study by Somers, 1999 husbands who were present during the delivery of their children believed that they were the most useful person to their wives during delivery. Furthermore, Pascali-Bonaro&Kroeger (2004) in Finland, reported that men and women believed likewise and both agreed that the husband's presence decreased woman's anxiety and increases the bond between the two.

Likewise, in Hungary, (Somers, 1999, Vehvilainen, 1998, IPWY 2000a) found that women whose husbands were present during labor and delivery showed a significant decrease in anxiety in comparison with a control group. Furthermore, the women in the present study considered that the husband's presence had a beneficial effect on the father-child relationship.

Vehvilainen-Julkunen and Liukkonen, (1998) who reported that early contact between a father and his child led to a strong relationship and, in contrast to traditional views, the father and his child could establish a close relationship without the mother as a mediator. Women in our study believed that observing childbirth creates a feeling of pride in the father which is similar to the Finnish study by Hawkins & Knox (2003). Also, Pascali-Bonaro&Kroeger (2004) found that all men believed that their presence in the delivery room had helped them accept their paternal responsibilities.

Likewise, (Dudgeon & Inhorn, (2004) reported that the fathers have an important function in supporting women during both pregnancy and labor. They indicated that much of the research during the past 30 years stated that prospective fathers can offer the pregnant woman important psychological, emotional and moral support.

One the other hand, in the current study, a sizable percentage of women (35%) and their mean score was 1.66 ± 0.530 had negative attitude towards

the presence of their husbands in the delivery room. They clarify that presence of the husband is not helpful to the mother. Also, a high mean score (3.20 ± 0.812) was obtained from women who claimed that it may lead to psychological disorders in the husband. Also, a mean score of 2.88 ± 0.277 revealed that it is unpleasant for the mother and is not tolerable for the husband. These findings reflected a cultural attitude of women of supporting their husband even if they needed them and accepts what comes from the man, and could be because women in upper Egypt are concerned that husbands might not cope with a complicated delivery and they are shy and considered it shameful to have a man in a delivery wither he is a husband or even a doctor. In addition, they may consider that the presence of the husband may lead to uncomfortable feelings in the woman. These findings are in agreement with the findings of Hawkins & Knox (2003) in Hong Kong, who found no significant relationship between husband's presence and woman's stress or pain perception. Also, Threenate (2001) in Croatia found that the husband's presence had no effect on the level of stress among women, and dosage of analgesic drugs. Women in the UK study believed that if the delivery were complicated, the partner could not fulfill his supportive role and might even transfer his anxiety to the mother. Also, Somers (1999), reported that men were worried about the possibility of the wife's death and that they (the husband) might faint or be unable to be supportive. After delivery, men reported periods of anxiety in the delivery room as well as perceptions of uselessness. In Finland, the worst experience of fathers was observing the partner's pain during childbirth.

In addition, the current study showed a positive statistical relation between a woman's age, education and working conditions and their willingness and positive attitude of the presence of the husband in the delivery room while giving birth. This finding could be related to the change of young, educated women, who are working on gaining knowledge and being willing to change the cultural view of most men in their community. In the same stream, Maimbolwa (2007) found that education and younger age are factors that affect the woman's attitude towards the presence of the husband in the labor room and gaining more western views.

In Egypt, the presence of the husband during delivery is less common than in the West and this has been related to tradition and culture and organization policy. Therefore, although husband's attendance is not currently practiced in our country in governmental hospitals and most private hospitals, it would seem that there is a willingness of the women to have husbands in the delivery room.

Conclusion

The results showed that the majority of women have a positive attitude towards the presence of their husbands at the childbirth.. Also, the majority of women considered that the husband's presence had a beneficial effect on the father-child relationship. In addition, the findings illustrated that young, educated and working mothers have statistically significant positive attitude towards the presence of husbands in the delivery room.

Recommendation:

- This finding has strong implications for maternity practices where the outpatient clinic in antenatal care or primary health care has to encourage the woman to bring her husband to antenatal care appointments and to be present during childbirth.
- Also, the findings suggest that providing facilities for the husband's presence in the delivery room is necessary.
- The study recommended accepting the presence of the husband in the labor room and providing training for the husbands about the skills needed to promote the active participation in the delivery.
- Also, the study recommended encouraging hospital administrators to develop "a Performance Protocol" to guide staff on realizing the new policy of having a father in the delivery room.
- Further research about the husband's attitude towards his presence, his ability to provide psychological support to his wife, and the effect of his presence on the married relationship is highly recommended.

Corresponding author

Nadia Abdallah Mohamed

Obstetrics & Gynecological Health Nursing, Faculty of Nursing, South Valley University
drnadia37@yahoo.com

References

1. Berry L (1988). Realistic expectations of the labor coach Journal of Obstetric, Gyne
2. Dudgeon M, Inhorn M (2004). Men's influences on women's reproductive health: medical anthropological perspectives. Social Science and Medicine, 59:1379-1395
3. Hawkins M, Knox S. The midwifery option (2003): a Canadian guide to the birth experience. Toronto: Harper Collins;
4. Hodnett ED, Gates S, Hofmeyr GJ, Sakala C, Weston J(2011). Continuous support for women during childbirth. Cochrane Database Syst Rev, 2:CD003766.
5. Hodnett ED, Gates S, Hofmeyr GJ, Sakala C, Weston J: Continuous support for women

- during childbirth. *Cochrane Database Syst Rev* 2011, 2:CD003766
6. Hodnett, 1999 Expectations and experiences of support during childbirth. *Midwifery*, 15(2):101–8.
 7. IPWY. (2000 a): Chinese husbands' presence during labour:a preliminary study in Hong Kong.
 8. IPW.Y. (2000 b). Relationship between partner's support during labor and maternal outcomes. *Journal of Clinical Nursing*, 9, 265-272.
 9. Kiernan, K., & Smith, K. (2003). Unmarried parenthood: new insights from the Millennium Cohort Study. *Population Trends*, 114, 26-33. London: Office of Population, Censuses and Surveys.
 10. Larkin P, Begley CM, Devane D: Women's experience of labour and birth: an evolutionary concept analysis. *Midwifery* 2009, 25:e49–e59.
 11. Madsen SA, Lind D, Munck H (2002). *Fædrestilknýting til spædbörn* [Fathers' involvement with infants]. Copenhagen, Hans ReitzelsForlag.
 12. Maimbolwa MC, Sikazwe N, Yamba B, Diwan V, of primigravida) 2007) [Master's Thesis]. Bangkok:program emphasizing husbands support on pain randomized controlled trial. *Health Educ Res*, 22:166–176.
 13. *ModarresNejad V. 1*(2005):Couples' attitudes to the husband's presence in the delivery room during childbirth *Eastern Mediterranean Health Journal*, Vol. 11, No. 4, 2005
 14. National Health Service (2005). NHS Maternity Services Quantitative Research (October), Prepared by TNS System Three for Kate Hawkins, Department of Health, London
 15. Noack H, Atai H. Klinikgeburt mit Ehemann. [Presence of the husband in the delivery room].
 16. Pascali-Bonaro D, Kroeger M (2004). Continuous female companionship during childbirth: a crucial resource in times of stress or calm. *J Midwifery Women's Health*; 49: 19-27.
 17. Sapkota S, Kobayashi T, Takase M (2011b). 'Husbands experiences of supporting their wives at childbirth in Nepal. *Midwifery*, in press Volume 27
 18. Sapkota S, Kobayashi T, Takase M(2011a) : Women's experience of giving birth with their husband's support in Nepal. *BJM*, 19(7):426–432.
 19. Sciarra J.J. *Gynecology and obstetrics* (1991). 6th volume 2 Philadelphia, lippincott, williams and wilkins.
 20. Siriwan, Yuenyong, · Jirapaet, Veena · O'Brien, Beverley A. (2008). Support from a close female relative in labor: the ideal maternity nursing intervention in Thailand. *Journal of the Medical Association of Thailand*-02
 21. Somers –Smith MJ. (1999). A place for the partner? Expectations and experiences of support during childbirth. *Midwifery*, 15(2): 101-8
 22. Sweet BR. *Mayes midwifery* (1988). A textbook for midwives, 11th ed. London, Baillière Tindal.
 23. Threenate S. (2001). Effects of childbirth preparation support person during labor in Zambian maternities.
 24. United States Agency for International Development (2005). The parenthood school makes delivery a “man's business” too. Washington, DC, United States Agency for International Development http://www.usaid.gov/locations/europe_eurasia/press/success/parent
 25. Vehvilainen –Julkunen K, Liukkonen, (1998). A Fathers experience of childbirth. *Midwifery*, 14 (1): 10-7
 26. Zadoroznyj M (1999). Social class, social selves and social control in childbirth. *Sociol Health*.

11/22/2012

The educational approach of allegory in religious texts

Dr. Kabiri Sayed Taghi¹, Kobra Rahimzadeh²

1. Assistant Professor of Islamic Azad University of Khoy Branch, Iran
2. Member of Young Researchers' Club of Islamic Azad University of Khoy Branch, Iran

Abstract: One of the educational methods of Quran and procedure of impeccable Imams (pbuh) is giving rational and sensible proverb (adage) and simile. So that, in this method, one series of literary words that are according to talent and conception of addressee and can memorize easily, replace difficult reasonable and retinal subjects in mind and don't forget rapidly. In fact, the application of allegory in education cause to thinking and trying of learner, on the other hand, teacher giving brief examples (instances) free self and the learner from wordiness and reveal the intention of orator (speaker) for the learners can understand the matters easily and also giving an example is the best means for thinking and reasoning and guiding of mankind. This method use for simplifying of education. In this paper (article) represented the Quranic and anecdotal application of this method.

[Kabiri Sayed Taghi, Kobra Rahimzadeh. **The educational approach of allegory in religious texts.** *Life Sci J* 2012;9(4):3621-3625]. (ISSN: 1097-8135). <http://www.lifesciencesite.com>. 536

Key words: Quran, Tradition, Allegory, simile, Education

1. Introduction

One of the methods of propagation and training and education, is the use of example and allegory that is used to explain the matter to the addressees and among the subjects in his/her mind. Holy Quran has frequently used allegory in instruction and teaching of its courses [teachings]. Allegory is the symbol of thought height, mind extent, and creativity of spirit, and those who have these properties, can usually enjoy the power of allegory. Sublime theosophists and great scientists have used allegory for the realization of spiritual facts and also for signifying delicate spiritual meanings to human being's mind. For example, philosophical and theosophical prose of sheikh-e-Eshrag, is very eloquent, and expressive and also contains literary order, because his writing style has some properties. He has shown the power of his creative mind in some of his works like "Resale-ye-Munes-al-oshag" [accustomed amorists dissertation] (Beheshti, 353/2). The use of allegory is frequently seen in prior scriptures like Torah and gospel, and also among the words of Holy apostle [Mohammad] and immaculate Imams [A.S]: and there is chapter in Torah which has been called "Solomon's allegories". But, in this article, we want to clarify this subject in Islamic texts namely Holy Quran and narratives of immaculate Imams [A.S]. As for the uses of allegory in philosophical, religious, heroic and literary works, we can stabilize that "allegory" is the good implement of understanding and summarization; it's opener of problems and an important implement for teaching and training, ([Mazlumi, 276).

2. Semantics

Parable[Mathal] means analog, like and equal. Its plural form, in Quran, is parables[Amthal] (Gorashi, 233/9). Parable is a word about something that is similar to another word about something else that one word explains and engages the other word (Ragheb, 759/1). In Arabic language, "parable" mainly means like and analog. In Arabic, it has three different forms that are "mathal", "mathel" and "mathil"; and it is the same as "Shabah", "shabeh" and "shabih" that all mean like. If someone uses words in the form of allegory, it is called "parable" (Zamakhshari, 72/1). Some vocabulary experts have written four meanings for allegory: "exemplification, simulate, liken, illustrating something, saying a story or narrative in the form of example" (Mo'in, 1139/1). Dehkhoda says "allegory is exemplifying, simulating something to another one and is among metaphors. And this kind of metaphor is the form of example" (Dehkhoda, 6107/4). But technically "parable" is simulating something to other thing or some Mather to another one so that the audience can take a spiritual advantage (Sajedi, 453). One of the interpreters of Quran says: "parable has a sublime importance and unveils hidden meanings, and clarifies unclear matters, and absent is so smart that is like present" (Zamakhshari, 72/1). We can say that parable is a great term that transmits a vastly semantic to the addressee in the format of few words, in a special way that the addressee doesn't need to explanation and widespread definition of the objectives or events. Therefore, in semantics parable means allegory, likeness and exemplification and technically it's the as simulation of some subjective matter to another

objective matter to help the addressee understand the matter better.

3. Role and position of examples:

Examples have an undeniable role in explanation and interpretation of discussions. Sometimes a good example, that is identical with objective, can make the subject intelligible for the audience. In total we can say that: example has effective and important role in different scientific, educative, social and morality discussions these effects are as below:

1. Example makes theorem sensible: since human being is accustomed with sensible subjects, and reasonable complicated facts are far from his thought access, sensible examples can make them clear and let us understand them in an interesting and safe way. Since Quran, as a breeding book, has reliance on objective matters, sometimes it brings some beautiful and sensible examples of people's routine life in order to make complicated concepts accessible for human mind (Makarem shirazi, 164/10). For instance, Allah says: "the similitude of those who spend their wealth in Allah's way is the similitude of a grain of corn that grows seven ears and each ear has one hundred grains" (Surah Bagarah, 261). The study of adventurous history of a person that sometimes lasts for a century, isn't easy for common people, but when they oppose a scene like the life of lots of plants [including burning, growing, beauty of their life and then inexistence] which lasts just for several months, they can easily see modality of their life in this in this clear looking glass (Makarem, 265/8).

2. Example makes the way closer: sometimes man resorts to different reasoning to prove a deep rational problem and still there is ambiguity around it. But giving a clear example that is coordinated with objective makes the way closer enhances the effect of reasoning's. Allah says in Holy Quran: "The parable of those who chose others as guardians rather than Allah, is the parable of spider whose nest is made of the most vulnerable threads, if they know" (Surah Ankabut, 41)

3. Example makes theorems public: there are lots of scientific discussions that in their main form, are just apprehensible for particular people, and commonality can't make use of them: but when they cooperate with an example, people in any degree of knowledge, can make use of them. Therefore examples, as a facility of generalizing knowledge and culture, have an undeniable usage. It has come in Holy Quran: "And whatever is in the heavens and earth, regularly prostrate to Allah, as do their shadows both in the mornings and evenings" (Rad, 15). Quran has named the falling of the shadows of objects upon the earth in mornings and evenings "genuflection", the reason is

that hereon Quran has brought the innate prostration that is at the nature of objects, in the form of example, and has awaked sense of people for understanding them meaning of innate prostration, and has made the way of transmission to this rational insensible fact for such people (Tabatabayi, 442/11).

4. Example makes head-strong people wordless: In many cases, the recitation of totality of theorems doesn't suffice to make head-strong people wordless, but when the theorem is introduced in the form of example, there is no chance for these people to pretext. For instance, Quran has clearly made mention of this point: "The likeness of the creation of Jesus with Allah is that of Adam, Allah created him from dust" (Surah Al-e-Emran, 59).

Parable makes rational and no sensible theorems sensible, makes the way closer to get to objectives, makes theorems public and finally, makes head-strong people wordless. It's for this reason that we see lots of examples in Quran each one is more interesting and effective than the other, because Quran is a book that has been sent down for all people in any level of thought and knowledge.

4. The application of allegory

The use of allegory and anecdote is among the most positive, natural and the most general methods of transference of subject, and thoughts (Gharaai, 169/7).

This is the reason that Allah orders the Holy prophet to make use of this method: "[O Mohammad!] Strike for them the similitude of the life of this world: it can be compared to the rain that we send down from the sky; it mingles with the earth and causes the growth of vegetations, but [due to the change of the season] plants and vegetations become dry like straw that the wind will scatter them around. Verily, Allah is Dominant over all things". (Surah Kahf, 45)

Allegory has different uses in Quran that are as below:

1. Quranic examples are often explicit ones that are at the prime constancy and stability. (Sajedi, 457).

Like this one: "only Allah, the Almighty is the true responsive position for the worshipers' invocations. Those to whom pagans pray besides Allah, have no power to respond; it is as if one would stretch forth his hands towards water, wishing that it may reach his mouth, but it does not reach it; the prayer of the disbelievers also gets nowhere". (Surah Rad, 14). This is an allegory which expresses the state of someone should come by the water[spring], open his/her palm, take water and then drink it, this is the actual and true way to eliminate the thirst. But someone who is far from water and wants to

eliminate the thirst and doesn't do any of the above mentioned arrangement, does nothing but opening palm and bringing it near mouth. In fact such a person doesn't drink water and just shows the figure of water drinking!

2. Examples which are derived from the symbols of the nature and simply bring forward excellent moral teachings. Like this one: "and the good land yields its vegetations abundantly by the will of its creator and Nurturer, but from the bad land doesn't come forth save bad and scanty. Thus we explain our words of Revelation to the people who are grateful [for the blessings]" (Surah Araf, 58). It has come in an awakening narrative of Imam Sadegh[P.B.H] that the Holy prophet told his desert in order to show them the identity of this fact that although sin is little and light, but by duplication it will be massive and eminent. In fact he wanted to make this subject sensible for them.(Makarem Shirazi, 334/18).

3. Some other examples are to show promise and usually mention to historical stories and happenings.(Sajjadi, 457).

Like this one: "and you dwelt in the dwelling places [and palaces] are those who wronged themselves; and it was made clear to you that how we dealt with them; and set forth similitude's for you[to warn you but you were not reminded]" (Surah Ebrahim, 45)

4. The examples that figure the inner attitudes and attributes of righteous and unrighteous individuals and groups, by the use of imagination power. Like this one: those who belied our signs and miracles and rebelled against them, the gates of the heaven shall not be open to them, nor they shall enter the paradise until the camel passes through the eye of the needle[which is an impossible act]; thus, do we recompense the sinners" (Surah Araf, 40). In this sentence, the entrance of sinners to paradise has been shown as stultification, and this is a metaphor that means such an act won't be ascertainable and they should always be despaired: as if one says: "I don't do this job unless the black crow becomes white of mouse lays" this verse has pointed this concept (Tabatabayi, 143/8).

5. Bringing short statement's that each one has its own adventure and case. This kind of examples can be found frequently in the language of every nation. Quran hasn't used any of the common examples of Arab nation, rather, conversely, some examples of Quran has been passed in Arab's language. Like this one: "... but the evil plots will plot the plotters themselves..." (Surah Fater43).

5. Types of allegory

Allegory is an anecdote that figures the inner attitudes and attributes of righteous and unrighteous individuals and groups and has used the imagination power well, yet it is the narrative of facts that form the basis of men's behavior; and with this illustration, the beauty and deformation of thoughts and suppositions out crops. In this case Quran has foregone up to the level of miracle (Marefat, 148). "Almizan" interpretation writer has implied two kinds of allegory: real allegory and fancy allegory. In fact allegory is a real or fancy story that narrator thinks it's his/her slightly concept in some aspects. So he/she brings it in his/her speech to help the listener to imagine that concept completely. For example when one wants to say: I have nothing, says: "I have no camels, neither manlike nor woman". Or when wants to say to the listener: you did nothing when you had the time to do, says: "you spoiled the milk in summer" and other examples like these. But assumptive and fancy examples are as we want to show to our addressee that the spending of wealth in Allah's way is the same as you give one and take multiple ones. And to represent this matter, we say: the likeness of what you spend in Allah's way is the likeness of grain, that grows seven ears and each ear grows one hundred grains. This is an assumptive and fancy example in this verse: "and the parable of an evil word is that of a bad tree, uprooted from the earth, it has no station and stability" (Surah Ebrahim, 26) or the example in this verse: "The similitude of those on whom learning the Turah was an incumbent and they learned it without practicing the commandments, is as the likeness of a donkey who is under the burden of books to carry without understanding a single word of them" (Surah Jum'ah, 5). Sometimes all the story isn't slightly, but her some part of it is important for us. In these cases, either we bring the needed part of story or we bring the whole story, just to complete the story, like the example of "spending some part of wealth for Allah" and the example of "grain". In this example allegory is the only grain that grows seven hundred grains, but it's planting and growing of seven ears doesn't participate in it and are told just to finish the story (Tabatabayi, 593/2). Therefore Quran uses frequent examples to guide man. Sometimes these examples are instances of someone's real life, and sometimes they are assimilations to natural affairs in the world of animals and plants. These examples are so communicative and meaningful that can be accounted one miracle aspect of Quran, as Allah says: "and indeed we have incited for people all sorts of parables in this Holy Quran so that they may [understand it better and] receive admonition" (Surah Zomar, 27).

Holy Quran has frequently used allegory to instruct its teachings that surface meanings of them are useful for all people, but the principle and reality meanings are for scientists and reasonably people, as the best recourse for thinking and intellection. Here, we allude to general and specific profit of using allegory:

I. General profit of allegory

Textual recitations of Quran are examples for right divine educations: and Allah has lowered to the level of public thought in order to present them, and there are no alternatives, because public people can understand sensible subjects. As a result all the meanings should be told to them at the form of sensible things and objective ones (Tabatabayi, 96/3). As Allah says: "[O Mohammad] strike for them the similitude of the life of this world: it can be compared to the rain that we send down from the sky; it mingle with the earth and causes the growth of vegetations, but[due to the change of season] vegetations and plants become dry like straw that the wind will scatter them around. Verily, Allah is Dominant over all things. (Surah Kahf,45) or Allah says in another verse: "Allah sends down water from the sky, and the rivers flow each according to its vastness; and the flood causes foam on the surface of the rivers; it is like the foam of the ore when they melt it in the furnace to make ornaments or utensils therewith. Thus Allah compares Truth with Falsehood; then as for the foam it passes away as scum upon the banks of the river but as for that which is of use to mankind [like water or ore], it remains on the earth. Thus does Allah set forth parables [to explain the divine words of revelation] (Surah Ra'd, 17). From this verse we can say that right divine educations are like the water that Allah sends from the sky. And this water, per se, is just water and nothing else. Neither its Quality is objective, but the difference is in the capacity of the land upon which it rains. Each land takes parameters, one less and one more; and these deals and measures are in the same land. And religions commandments and rules are like this (Tabatabati, 95/3). Therefore, by examples, Quran wants to predispose the use of wisdom and reason in understanding the facts (Mesbah Yazdi, 30/2). In fact, Allah wants to compel his servants to think about the affairs of life and nature, because he wants them not to accept social theorems and problems slavishly, rather he wants them to accept by the use of thought and reason. One can just get the real faith in this way.

II. Special profit of allegory

Can understand the general and surface meanings of Qur'anic allegories, but only scientists and reasonably people can understand and discover

their real meanings and ultimate purposes. They are those who think about low down and don't suffice to surface meaning (Tabatabayi, 132/16). As Allah says: "and these parables we put forth mankind in general, but only the learned men understand their deep meanings" (Surah Ankabut, 43).

The reason for this concept is the statement "but only the learned men understand", because it was possible to be said: "but only the learned men believe". Saying "understand" instead of "believe" show that the purpose is to know the deep meanings of these examples, otherwise there are lots of unlearned people who believe in the external of these parables. So, the level of understanding the parables that are found in Holy Quran is different according to the intelligence and sense of men. Some listeners only here the terms and imagine their simple meanings, because they don't think deeply. Yet, there are others who think about the deep meanings and understand the exact purpose. (Tabatabayi, 196/16)

6. Results

1. Holy Quran has frequently used allegory in teaching and instructing its courses and teachings. Quran uses parables and allegories in order to cause people understand spiritual facts and excellent heavenly concepts.

2. Allegory makes rational theorems sensible, makes the way of achieving to the objective closer, makes theorems public and finally, makes head-strong people word less. It's for this reason that we see lots of examples in Quran that each one is more interesting and effective than the other, because Quran is a book that has been sent down for all mankind in any level of thought and knowledge.

3. To express scientific and rational subjects, using examples is the best way for manifesting matters and understanding them. For this reason, application and use of example is a Quranic way. In this way, Quran makes no sensible and rational concepts, sensible for the mind of addressees in the form of stories and useful examples and this helps to clear the essence of concept for people.

4. There are different views about the kinds of allegory, but we can divide allegories into two main groups: real allegory and fancy or assumptive allegories. In fact allegory is a real or fancy story that narrator thinks it's like his/her slightly concept in some aspects. So he/she brings it in his/her speech to help the listener to imagine that concept completely and better.

5. Textual recitations of Quran, are examples of right divine educations; and Allah has lowered them to the level of public thought in order to present them, and there is no alternatives, because public people

can just understand sensible subjects. As a result all the meanings should be told to them at the form of sensible things and objective ones.

6. Although all people can realize the general and surface meanings of Quranic allegories, but only scientists and reasonably people can understand and discover their real meanings and ultimate purposes they are those who think about down and don't suffice to surface meaning.

References:

1. Quran translation, Fuladvand, Mohammas Mahid; Dar-al-Quran- al-Karim, Tehran; first edition, 1415.
2. Nahj-al-Balaghah, Dashti, Mohammads; Payam-e-Adalat press, Tehran; first edition, 2005.
3. Behshti, Mohammad; Abujafari, Mahi; Fagihi, Alinagi; Mustim scientist's views in teaching and its bases, Hovzeh va Daneshgah press, Qum, Tehran; third edition, 2007.
4. Dekhoda, Ali Akbar; dictionary; Dekhoda institution; Tehran.
5. Ragheb-e-Esfahni, Hosein-Bin-Mohammad; Almofradat Fee gharib-al-Quran; Dar-al-Elm-Al-Darashameiah; Demashgh, Beyroot; first edition; 1412.
6. Zamakhshri, Mahmud; Alkashaf-min-Hagayege ghavamez-al-Tanzil, Dar-al-kotob-al-Arabi; Beyroot, third edition; 1407.
7. Sajedi, Abulfazl; The language of religion and Quran; Imam Khomeiny instructional and educational center; Qum, second edition; 2006.
8. Tabatabayi, Mohammad Hosein; Al-Mizan-Fi-Tafsir-al-Quran; the office of Qum scientific compass Islamic press; Qum; Fifth edition; 1417.
9. Marefat, Mohammad Hadi; Quranic sciences; Zavelqurba press; Qum; eleventh edition; 2005.
10. Qarati, Mohsen; Noor interpretation; the cultural center for Quranic lessons; Tehran; Eleventh edition; 2004.
11. Gharashi, Seyed Ali Akbar; Gamus-e-Quran; Dar-al-kotob-al-Eslameiah; Tehran; Six edition; 1992.
12. Masudi, Abd-al-Hadi, The way Hadith realization; samt press; Tehran; third edition; 2007.
13. Mesbah Yazdi, Mohammad tagi, Quran recognition; Imam Khomeiny instructional and educational center press; Qum; 2008.
14. Mazlumi, Rajab Ali; A step on Islamic training; Afagh press; Tehran; seventh edition 2007.
15. Moin, Mohammad, Farsi dictionary; Amirkabir, press; Tehran; 1992.
16. Makarem-e-Shirazi, Naser; Tafsir-e-Nemooneh; dar-al-kotob-al-Eslameiah press; Tehran; first edition; 1995.

9/6/2012

Introducing an Economic Plan of Optimum Designing in the Joist Floor Slabs Construction

Dr. Ahmad Akbarlou

Faculty of Engineering, Tabriz Branch, Islamic Azad University, Tabriz, Iran
E-mail: Ahmad.akbarlou@ymail.com

Abstract: In the present paper, considering joisted floor overuse in most of the residential, office and other types of buildings, numerous researches have been carried out into technical and theoretical problems. The results have been compiled as article and it has become clear that there is a drastic gap concerning financial matters of a variety of structures in building regulations. A steel building with joisted floor was considered to commence this technical and economic research. The effect of shifting floor framing direction of the joists on floor spans has been calculated and compared (first on big span, next on small span) in the amount of used steel including the main steel girder weight and used bar weight in joist and the total cost of floor construction calculated according to it. The results show that in the case of building with joisted floor along the big span of floor span (from both direction of framing), 10% - 39% and 8% - 28% are saved in the case of steel use and floor construction costs, respectively. According to statistics concerning the city of Tabriz, 22000 tons of steel on average and about 440 billion Rials that is equal to 19.8 million \$ would be saved in the cost of floor construction. These amounts of saving for the whole country (for Iran) are 580000 tons of steel and 12000 billion Rials that is equal to 540 million \$.

[Ahmad Akbarlou. **Introducing an Economic Plan of Optimum Designing in the Joist Floor Slabs Construction.** *Life Sci J* 2012;9(4):3626-3633]. (ISSN: 1097-8135). <http://www.lifesciencesite.com>. 537

Key words: Joisted floor, optimal choice of framing direction, optimal steel use, financial saving.

1. Introduction

Utilizing joisted floor in country buildings is a common task because of its advantages such as using less steel, concrete, framing, possibility of manual installation, being thermal insulator, less weight, quick installation, and reasonable strength.

This study deals with the uncontrolled steel use in order to save financial expenses in building industry. This seems to be necessary because of the increasing demands of the society for appropriate building construction with less total cost.

On the other hand, because of insufficient technical and economical studies in the field of building construction methods mainly residential buildings, this research method may play a role in changing research issues and methods. Although quality and strengthen of structures, have been improved, it is obvious that less attention has been paid to the engineering economy. So far, no regulations or codes have been compiled and published by technical organizations or legal authorities. Moreover, uncontrolled and exceptional use of steel in country buildings, leading to increasing need for steel importation and expense increment, shows this research matters importance.

In the present paper, it has been proposed that related organizations such as Housing and Urbanization Organization, Engineering Constitution, etc., should care about economic matters in designing and constructing of building in addition to inspection problems, quality control and theoretical problems through compiling necessary regulations and codes.

2. Research Method

A residential building with steel structure and joisted floor, according the following plan, in two modes of framing, i.e. modes a and b, has been selected. After floor designing, the weight of used steel in the main girder and bar of the joist estimated and total weight of used steel has been calculated and compared in two cases of a and b. Then the costs of floor construction including the cost of main girder and joisted floor have been calculated and compared with to the price list of the year 2010 (the last official prices) that exchanged to the prices of year 2012.

In floor calculations, the design of steel girder considering vertical loads has been done by allowable stress method and based on Iranian steel code. The joist has been designed by ultimate strength method based on the code CP 110, rule 54/1405, dated on 97/06/12 (leaflet no.94) published by strategic planning and supervision organization.

Case a) the main steel girder in axes A and B, and the direction of floor joist in L1 direction are as following figure ($L_1 > L_2$)

Case b) the main steel girder in axes 1 and 2, and the direction of floor joist in L2 direction are as following figure ($L_1 > L_2$)

4- Floor elements design and total cost of their preparation and construction.

The study continues as follows with an example.

$$L_1 = 5 \text{ m} \quad , \quad L_2 = 3 \text{ m}$$

$$PL = 650 \text{ kg/m}^2 \quad , \quad LL = 200 \text{ kg/m}^2$$

Case a:

1-1-a: Design of steel girder in case (a), with a span of $L_2=3m$.

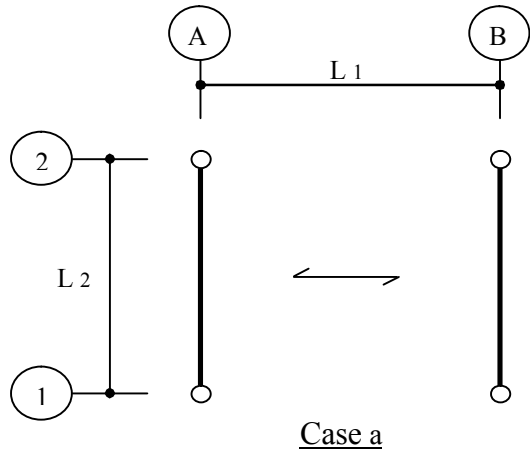

Case a

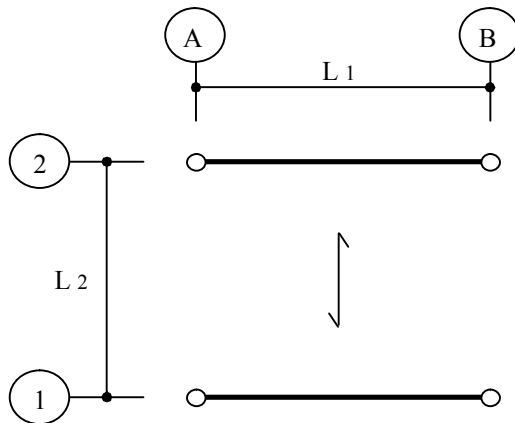

Case b

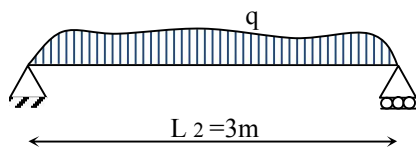

$$q = (650+200) \cdot \frac{5}{2} = 2125 \text{ kg/m}$$

$$M = \frac{qL^2}{8} = \frac{2125 \cdot 3^2}{8} = 2391 \text{ kg.m}$$

$$W = \frac{M}{F_b} = \frac{239100}{1584} = 151 \text{ cm}^3 \text{ use : IPE 18}$$

$G_1 = 6? 8.8 = 113 \text{ kg}$ the weight of main steel girders.

1-2- a: Design of the floor joist (tensile bar) in case (a), with a span of $L_1=5m$.

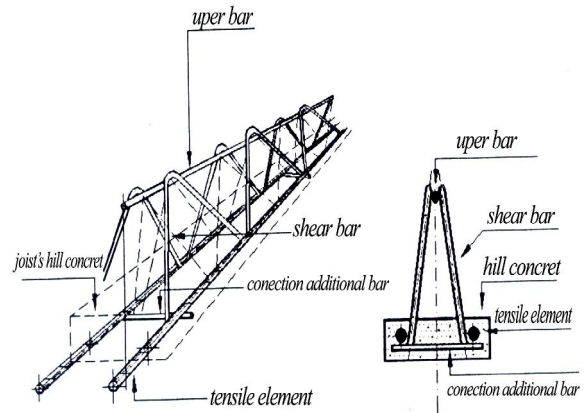
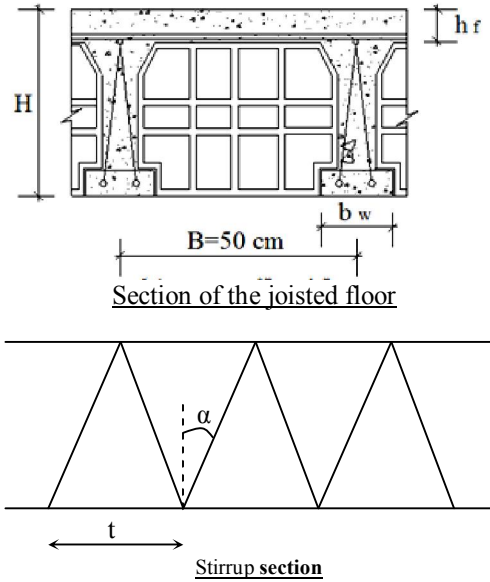

Defining of the signs	
$L = 5 \text{ m}$	Joist span
$H = \frac{L}{20} = 25 \text{ cm}$	Thickness of floor
$h_f = 5 \text{ cm}$	Thickness of concrete slab
$b_w = 10 \text{ cm}$	Width of heel
$h_e = 230 \text{ cm}$	Effective height
$Z = 0.9h_e$	Elastic arm
f_{cu}	compressive stress of the joist concrete
$t = 20 \text{ cm}$	The distance of stirrups
$f_y = 4200 \text{ kg/cm}^2$	tesile bar yield stress
$\sigma_a = 1400 \text{ kg/cm}^2$	Stirrup allowable stress
$f_c = 200 \text{ kg/cm}^2$	28- day concrete compression

strength	
$\alpha = 58^\circ$	Stirrup's angle
B = 50 cm	Distance of the joists
$A_1 = A_S =$	tensile bar Area

Design based on the USD (ultimate stress design) method using CP110 code:

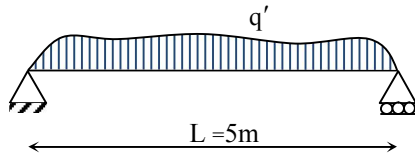

$$q' = (1.4DL + 1.6LL) \times .5$$

$$q' = (1.4 \times 50 + 1.6 \times 00) \times .5 = 615 \text{ kg/m}$$

$$M = \frac{q' L^2}{8} = \frac{615 \times 2^2}{8} = 1922 \text{ kg.m}$$

$$M_u = 0.87 F_y A_s \left(h_e - \frac{h_f}{2} \right)$$

$$192200 = 0.87 \times 200 \times A_s \times \left(3 - \frac{5}{2} \right)$$

$$A_s = 2.57 \text{ cm}^2 \quad \text{use } 2\Phi 14 \text{ AIII}$$

$$M_u = 0.4 f_{cu} B h_f \left(h_e - \frac{h_f}{2} \right)$$

$$192200 = 0.4 \times f_{cu} \times 0 \times \left(3 - \frac{5}{2} \right)$$

$$f_{cu} = 94 \frac{\text{kg}}{\text{cm}^2} < 200 \frac{\text{kg}}{\text{cm}^2} \quad \text{o.k.}$$

2-2-a: Design of joist stirrups using ASD (Allowable stress design) method

$$q' = (DL + LL) \times .5 = 425 \text{ kg/m}$$

$$\alpha = 58^\circ \quad V_{\max} = \frac{q' L}{2} = 425 \times \frac{5}{2} = 1063 \text{ kg}$$

$$\tau = \frac{V_{\max}}{Z \cdot b_w} = \frac{1063}{0.9 \times 3 \times 0} = 5.14$$

$$5.14 > 4.2 \text{ kg/cm}^2 \quad \text{Stirrup is need}$$

$$A_2 = \frac{V \cdot t}{Z \cdot \sigma_0 (\sin \alpha + \cos \alpha)}$$

$$A_2 = \frac{1063 \times 20}{1400 \times 0.9 \times 23 \times (0.85 + 0.53)}$$

$$A_2 = 0.53 \text{ cm}^2 \quad \text{use } \Phi 8$$

3-2-a: Design of compressive bar according to the code.

$$A_3 : \text{use } \Phi 10$$

4-2-a: Thermal bar perpendicular to joist direction.

$$A_4 = \frac{1.75}{1000} \times \text{Concrete slab Area}$$

$$A_4 = \frac{1.75}{1000} \times 00 \times 00 = 0.875 \text{ cm}^2$$

$$\text{use } 4\Phi 6 / \text{m}$$

5-2-a: design of thermal bar parallel to joist direction.

$$A_5 = \frac{1.25}{1000} \times 00 \times 00 = 0.625 \text{ cm}^2$$

$$\text{use } 2\Phi 6 / \text{m}$$

6-2-a: Shear reinforcing bar

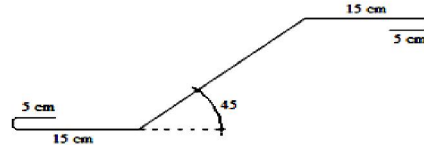

$$A_6 : \text{use } \Phi 8 \quad L = 75 \text{ cm}$$

7-2-a: Negative moment bar

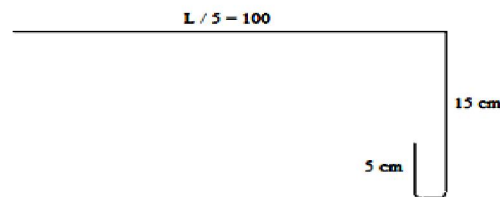

$$A_7 = 0.15 A_s$$

$$A_7 = 0.15 \times 0.54 = 0.46 \text{ cm}^2$$

$$\text{use } \Phi 8 \quad L = 120 \text{ cm}$$

8-2-a: Joist rib bar

$$\text{Live load } q'' = 200 < 350, \quad L > 4 \text{ m}$$

$$A_8 = \frac{1}{2} A_s = \frac{1}{2} \times 0.54 = 1.54 \quad \text{use } 2\Phi 10$$

9-2-a: Calculating the weight of bar used in joist

Table 1: Calculating the weight of bar

POS	ϕ / Φ	N	L	G (kg/m)	W (kg)
A ₁	Φ14 AIII	12	5	1.21	72.6
A ₂	Φ8 AI	6	5×2.5	0.395	30
A ₃	Φ10 AII	6	5	0.617	18.5
A ₄	Φ6 AI	20	3	0.222	13.3
A ₅	Φ6 AI	6	5	0.222	6.7
A ₆	Φ8 AI	12	0.75	0.395	3.6
A ₇	Φ8 AII	12	1.2	0.395	5.7
A ₈	Φ10 AII	2	3	0.617	3.7

Weight (AI = 54 kg, AII = 28 kg, AIII = 73 kg)

Total weight of bar = 113 kg

Total steel use = 155kg

Case b:

1-1-b: design of steel girder in mode b with span of $L_1=5m$.

$$q = 850 \times 0.5 = 1275 \text{ kg/m}$$

$$M = \frac{1275 \times 5^2}{8} = 3984 \text{ kg.m}$$

$$W = 252 \text{ cm}^3 \Rightarrow \text{use IPE22}$$

$$G_2 = 10 \times 6.2 = 262 \text{ kg}$$

10-2-a: Calculating the cost of providing and constructing the floor using Iranian price list of construction field published in 2009(the last official price list)

Table 2:

Row	Operation description	number of price list	unit	amount (kg)	unit price (Rial)	Total price (Rial)
1	Providing and executing of AI bar	070101	kg	54	8980	484920
2	Providing and executing of AII bar	070201	kg	28	8000	224000
3	Providing and executing of AIII bar	070205	kg	73	6360	464280
4	Additional price of joist truss	070301	kg	122	145	17690
5	Providing and executing of joisted floor whit 25 cm thickness	100102	m ²	15	122000	1830000
6	Providing and executing of bearing girder	090211	kg	113	8830	997790
Sum of total value=4018680× 1.8 = 7233624						

The exchange coefficient of prices of year 2010 - 2012 based on the cost coefficient and daily prices = 1.8

1-2-b: design of floor joist (tensile bar) in mode b with span of $L_2=3m$.

$$q = 615 \text{ kg/m} \quad M = \frac{615 \times 3^2}{8} = 692 \text{ kg.m}$$

$$M_u = 0.87 \times 200 \times S \times (3 - 2.5)$$

$$A_1 = A_S = 0.92 \text{ cm}^2$$

use 2Φ8 AIII

2-2-b: design of joist stirrup using ASD (Allowable stress design)method.

$$q' = 425 \text{ kg/m}$$

$$V = 425 \times \frac{3}{2} = 638 \text{ kg}$$

Shear stress :

$$\tau = \frac{638}{0.9 \times 3 \times 0} = 3.1 < 4.2 \text{ kg/cm}^2$$

According to the code :

$$A_{\min} = 0.0015 b_w t = 0.0015 \times 0 \times 0 = 0.3 \text{ cm}^2$$

use $A_2 = \Phi 6$ AI

3-2-b: design of compressive bar according to the code.

$$A_3 : \Phi 8 \text{ AII}$$

4-2-b: thermal bar perpendicular to joist

$$A_4 : 4\Phi 6 \text{ AI}$$

5-2-b: design of thermal bar parallel whit joist

$$A_5 : 2\Phi6 /_m \text{ AI}$$

6-2-b: shear reinforcing bar

$$A_6 : \Phi8 \text{ AI} \quad L = 75 \text{ cm}$$

7-2-b: negative moment bar

$$A_7 : 0.15A_1 = 0.15? \quad ? .5 = 0.15 \text{ cm}^2$$

use $\Phi6 \text{ AII}$

8-2-b: Joist's rib bar:

according to the code joist's rib is not need.

$$L = 3 < 4$$

9-2-b: Calculating the weight of the bar used in the joist.**Table 3**

POS	ϕ / Φ	N	L	G (kg/m)	W (kg)
A ₁	$\Phi8 \text{ AIII}$	20	3	0.395	24
A ₂	$\Phi6 \text{ AI}$	10	3×2.5	0.222	16.7
A ₃	$\Phi10 \text{ AII}$	10	3	0.395	12
A ₄	$\Phi6 \text{ AI}$	12	5	0.222	13.3
A ₅	$\Phi6 \text{ AI}$	10	3	0.222	6.7
A ₆	$\Phi8 \text{ AI}$	20	0.75	0.395	5.9
A ₇	$\Phi6 \text{ AII}$	20	0.8	0.222	3.6

(AIII = 24 kg), (AII = 16 kg), (AI = 43 kg)

Total weight of bar = 83 kg

10-2-b: Calculating the cost of providing and constructing the floor with Iranian price list of construction field published in 2009**Table 4**

Row	Operation description	number of price list	unit	amount (kg)	unit price (Rial)	Total price (Rial)
1	Providing and executing of AI bar	070101	kg	43	8980	386140
2	Providing and executing of AII bar	070201	kg	16	8000	128000
3	Providing and executing of AIII bar	070205	kg	24	6360	152640
4	Additional price of joist truss	070301	kg	53	145	7685
5	Providing and executing of joisted floor whit 25 cm thickness	100102	kg	15	122000	1830000
6	Providing and executing of bearing girder	090211	kg	262	8830	2313460
Sum of total price with operating overhead coefficient (Rial) = (4817925×1.8= 8672265)						

The exchange coefficient of prices of year 2010-2012 based on the cost coefficient and daily prices = 1.8. In the table 5 the weight of steel use for different spans is presented after designing and calculating like upper method.

Table 5: the weight of used steel and the percent of the steel use reduction in 10 modes with different spans and two different modes of joist position (a & b).

Row	Span of joist (m)	Span of the main girder (m)	Weight of used bar (kg)	Weight of used steel (kg)	Sum of the weight of steels (kg)	Decrease percent of steel use	L_2/L_1
1	3	4	71	179	250		1.33
	4	3	83	113	196	%22	
2	3	5	83	262	345		1.67
	5	3	155	113	268	%22	
3	3	6	105	433	538		2
	6	3	196	134	330	%39	
4	3	7	123	591	714		2.33
	7	3	315	134	449	%37	
5	4	5	164	361	525		1.25
	5	4	196	246	442	%16	
6	4	6	197	506	703		1.5
	6	4	262	246	508	%28	
7	4	7	230	687	917		1.75
	7	4	420	289	709	%23	
8	5	6	293	589	882		1.2
	6	5	320	422	742	%16	
9	5	7	342	799	1141		1.4
	7	5	525	491	1016	%11	
10	6	7	460	928	1388		1.17
	7	6	624	685	1300	%6	

In the plan of the joists and girders, L_2 is the bigger span and L_1 is the smaller span.

Table 6: calculating the cost of construction of the floor.

Row	Joist's span (m)	main girder span (m)	Total cost of the floor (Rial)	Percent of the cost decrease	L_2/L_1
1	3	4	5820327		1.33
	4	3	4951330	%15	
2	3	5	7829127		1.67
	5	3	6530355	%17	
3	3	6	7052700		2
	6	3	11327326	%28	
4	3	7	12495395		2.33
	7	3	11041051	%24	
5	4	5	11389071		1.25
	5	4	9952431	%13	
6	4	6	14768331		1.5
	6	4	11821657	%20	
7	4	7	18769642		1.75
	7	4	16702715	%11	
8	5	6	18448475		1.2
	6	5	16472216	%11	
9	5	7	24975127		1.4
	7	5	22950756	%8	
10	6	7	30274466		1.17
	7	6	27956667	%8	

In the plan of the joists and girders, L_2 is the bigger span and L_1 is the smaller span.

5 - The diagram of comparing steel use in different modes of floor framing:

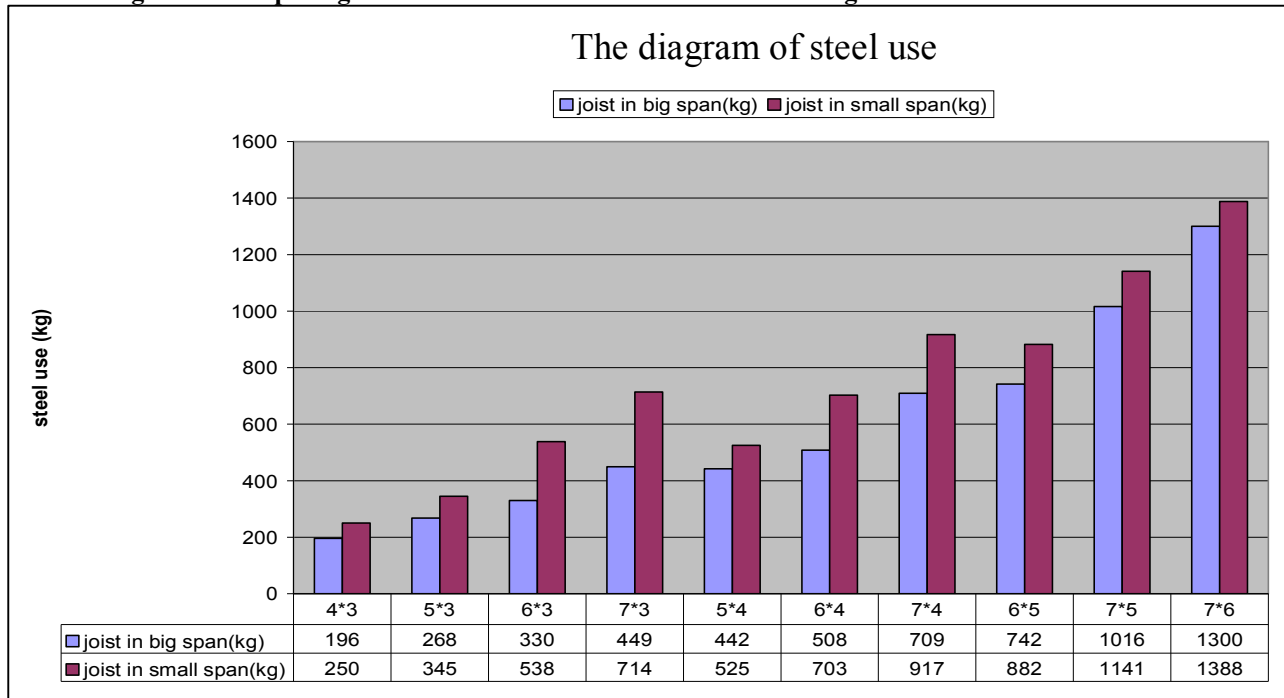

Diagram 1: the curve of steel use.

The upper diagram indicates that in all cases when joist is located in bigger span, the use of steel decreases considerably.

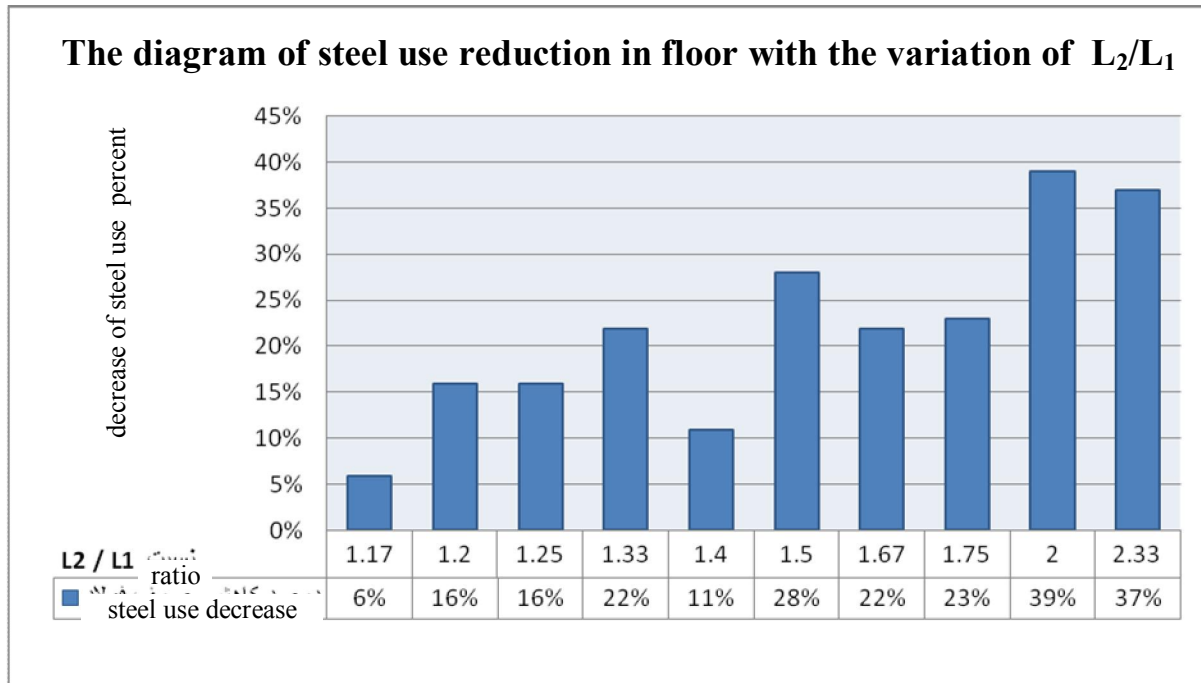

Diagram 2: The curve of steel use reduction with the variation of L_2/L_1

As it is seen, when the ratio of L_2/L_1 increases, steel use percent decreases.

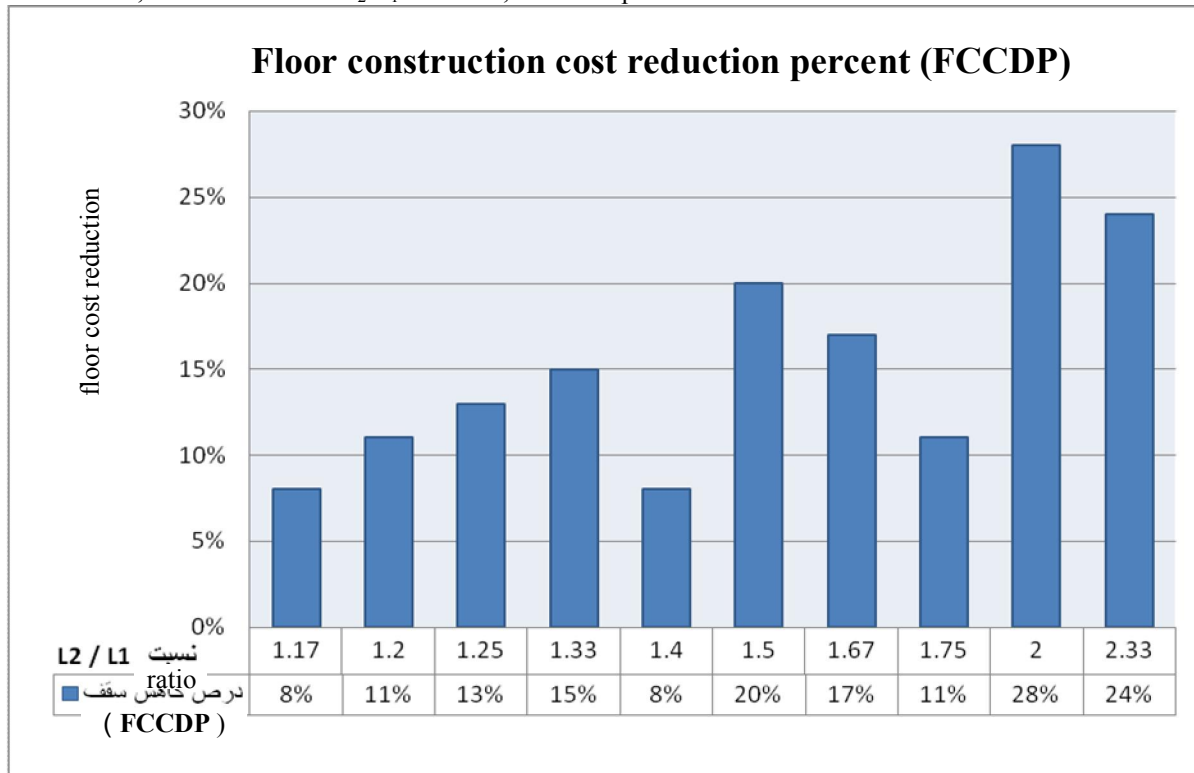

Diagram 3: Floor cost reduction percent (FCCDP)

As the above diagram indicates, by increasing L_2/L_1 ratio, floor construction cost percent decreases (except two cases).

5. Conclusions

- 1) All the studied cases being the common spans used in joisted floor have been compared with the obtained results on diagram (1) which indicates that when the joist is constructed on the big span, steel use decreases considerably.
- 2) Considering diagram 2, it can be observed that when L_2/L_1 (ratio of big span to small span) increases, the steel use decreases, and when $L_2/L_1 = 2$, the maximum decrease can be observed.
- 3) Considering diagram (3), it can be deduced that in all cases when the joist is designed on the big span, the cost of joisted floor construction decreases.
- 4) Based on the obtained results on diagram (3), when L_2/L_1 increases, the cost decreases; and the maximum decrease is when $L_2/L_1 = 2$.
- 5) Economical result of the research:
- 6) The average amount of steel reduction (22%) and the average amount of the floor cost reduction (16.5%) can be obtained from diagram (3).

Through calculating the average amount of used steel in joisted floor which is 26 kg/m^2 , 6.4 kg less steel will be used per square meter of joisted floor. Therefore, according to the statistics on average building construction of the one year for a city such as Tabriz, there has been more than 3500000 square meter and assuming 98% of construction with joisted floor, 22000 tons of steel

would be saved which amounts to 440 billion Rials saving (equal to 20 million \$). Thus, for the whole country (for Iran) it would be 580000 tons of steel use reduction and 12000 billion Rials saving (equal to 540 million \$). With such saving for a city such as Tabriz, we can construct 1500 residential building units, and for the whole country about 40000 residential building units, each unit with 80 m^2 of area.

Therefore, with serious attention to this plan, there will be less need to steel importation and there will be huge savings on cost of constructing the buildings.

References:

1. Iranian building national code, code number: 10, "designing and constructing steel structure Buildings".
2. Iranian price list of construction field published in 2009, "mporg" organization, <http://tec.mporg.ir>.
3. precast joist floors, published from "mporg" organization, <http://tec.mporg.ir>.
4. Engineering constitution organization of East Azerbaijan in Iran home page for deriving the statistics of buildings construction in Tabriz Iran (<http://azarnezam.ir>).
5. Statistical center of Iran for deriving the buildings constructions statistics of in Iran published in 2009 (<http://sci.org.ir>).
6. Leaflet no. 94, published from "mporg" organization in 1997. (<http://tec.mporg.ir>).

11/16/2012

The theoretical study and finite elements of effect in the height changes to threshold on the shear strength of steel shear walls

Hedayat Veladi, ArashSazghari

Faculty of Civil Engineering, Tabriz University, Iran

hveladi@tabrizu.ac.ir

Abstract: In this article, studying the theoretical behavior of steel shear walls by Veladi et al and comparing its experimental results clarified that the degree of theoretic resistance has difference with experimental results. This difference is originated from the lack of width to height effect (b/h) on the shear resistance. Thus, to remove the problem, using ABAQUS software has been carried out to calculate a coefficient which is b/h proportion function. After comparing the obtained results from modeling and experiment, the authenticity was confirmed. Also, to reach to the study's purpose, modeling of samples from steel shear and material except the height was carried out efficiently. Then, by the use of experimental results and computer based modeling's, the extraction of a relationship was carried out to achieve multiple functions to theoretic relations.

[Hedayat Veladi, ArashSazghari. **The theoretical study and finite elements of effect in the height changes to threshold on the shear strength of steel shear walls.** *Life Sci J* 2012;9(4):3634-3640]. (ISSN: 1097-8135). <http://www.lifesciencesite.com>. 538

Key words: Steel shear walls, theoretical relations, periodical behavior, experimental behavior, experimental studies, ABAQUS software.

1. Introduction

About two decades ago, serious and considerable studies have been carried out on the steel shear walls. Due to the similar behavior of these systems with decks and sheets in terms of shear resistance, the similar relations of the system were considered. Benefits such as being economical, lightweight and idea plasticity behavior justify the importance of studying these panels more. The steel shear walls are enough easy to be achieved than other similar systems being jointed or connected as two bolt and curve to their surrounding frame and because it does not have any tensions concentrate, therefore, no need to accurate control of the bolts. The first serious work of the panel shear strength after buckling was carried out by wanger in 1931. The experiments were done by wanger based on the thin layer of aluminum shear panels made him to present the theory of stretching field (8). After him, many scientists such as Cohen, Bussler, Rocky, Porter and others studied their researches on the stretching field of deck-sheets diameters and their final resistance calculations, the stiffness sided panels were gradually evaluated. The regular bases of these studies during 20 years were mostly subjected to the application of diametrical stretching field being made after steel shear buckling. During the limited years, the steel shear walls with strong pre-fabricated steel sheets to prevent its buckling were used in a few buildings with inspiration of sheeting industry. The planning of using steel shear walls with thin thickness was carried out based on some useful studies on sheets for

the first time in 1980s in Alberta college, Canada by Koolak and et al. these researchers concentrated merely on the theoretical and experimental studies based on steel shear walls with thin-thickness replacing a series of flanked stretching bars.

2. The theoretical behavior

Now, the behavior of the plate is being divided into three sections and the shear and tension (buckling) resistance would be reviewed in each section:

- 1- Pre buckling behavior
- 2- Elasticity – plasticity after buckling to the delivery of plate (sheet) tension
- 3- Plasticity after delivery to plate (sheet) fault tension

Pre-buckling behavior

In this section, the shear force continues from zero up to the plate buckling begins. Also, in this section, the linear relations and plate regulations are completely accurate. Of course, the range here is much lower than other parts. If the thickness of the plate is much lower than other dimensions (lower than 500), this section can be ignored.

The critical stress using classical plate theory is:

$$(1) \quad \tau_{cr} = \frac{k\pi^2 E}{12(1-\nu^2)} \times \left(\frac{t}{h}\right)^2$$

Grater or equal to one

$$k = 5.35 + 4\left(\frac{b}{h}\right)^2$$

For b/h Smaller or equal to one

For b/h $k = 5.35(\frac{b}{h})^2 + 4$



Figure 1. Plate of steel shear wall

b = the length of panel
 h = the length of panel
 t = the thickness of plate
 (4) $F_{cr} = b \times t \times \tau_{cr}$

(5) $U_{cr} = \gamma_{cr} h = \frac{\tau_{cr}}{G} \times h$

The plasticity-elasticity behavior after buckling to plate delivery tension

The section can be considered the plate (sheet) as diametrical (diagonal) stripes with 45° . (1).

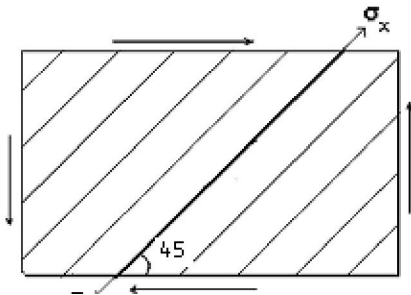

Figure 2. The hypothesis of stripes elements

The strain distribution on the stripes is not fixed in reaching to delivery tension based on Dr. Elghaiee experiments (2); but, it is variable as following form:



Figure 3. Strain distribution in stripes elements

(6) $\Delta_y = \epsilon_y L + (\epsilon_p - \epsilon_y) \frac{L}{3} = (2 + \alpha) \epsilon_y \frac{L}{3}$

(7) $\epsilon_p = \alpha \epsilon_y$

(8) $\beta = \frac{2 + \alpha}{3}$

(9) $\epsilon = \frac{\beta \sigma_e}{E}$

Which α represents the coefficient of variation in the range of 5 to 20. When the thin-layered plate and its limited members have enough stiffness, the degree of α would be about 20 while the thick-layered plate would be decreased to 5 due to their softness and flexibility elements.

$2.32 \leq \beta \leq 7.33$ $5 \leq \alpha \leq 20$

Now, if the direction of X along with stripe and Y as vertical direction were considered, the strain distribution would be as following during the delivery strain:

(10) $\epsilon_{xe} = \frac{(1 + \nu)}{E} \times \tau_{cr} + \frac{\beta \sigma_e}{E}$

(11) $\epsilon_{ye} = -\frac{(1 + \nu)}{E} \times \tau_{cr} - \nu' \frac{\beta \sigma_e}{E}$

Which the position coefficient, ν' , in the plastic zone would be equal to 0.5 and plate delivery strain, σ_e based on "phone-misses" criteria could be obtained as following:

(12) $\sigma_e \cong F_y - \sqrt{3} \times \tau_{cr}$

The transformation of these strains in the direction of the panel, the shear strain would be governed during the delivery strain of the panel:

(13) $\epsilon_{ye} = -\frac{(1 + \nu)}{E} \times \tau_{cr} - \nu' \frac{\beta \sigma_e}{E}$

(14) $U_e = \left(\frac{\tau_{cr}}{G} + (1 + \nu') \left(\frac{\beta \sigma_e}{E} \right) \right) \times h$

During the plate is reaching to delivery strain, total shear resistance can be obtained by balancing method. Then, we will have:

(13) $\gamma_E = \frac{2(1 + \nu)}{E} \times \tau_{cr} + (1 + \nu') \left(\frac{\beta \sigma_e}{E} \right)$

(14) $U_e = \left(\frac{\tau_{cr}}{G} + (1 + \nu') \left(\frac{\beta \sigma_e}{E} \right) \right) \times h$

(15) $F_e = (\tau_{cr} + 1/2 \sigma_e \sin 2\theta) bt$

The angle θ according to the Canadian regulations, it would be:

(16) $\tan^4 \theta = \frac{1 + \frac{tl}{2A_c}}{1 + th_s \left(\frac{1}{A_b} + \frac{h_s^3}{360I_c L} \right)}$

A_c = the area of columns section

I_c = the inertia of columns

H_c = the height of floor

A_b = the surface of the cross-section in a column

It must be noted that, the angle error effect on the ultimate strength must be very less than 0.10%.

The plasticity behavior after delivery to the fault of plate strain

In this step, the theoretical concepts of the plasticity are not effective but the plate can be considered as the stripe elements in this regard. The only difference with the latest step is the change of elasticity modulus which is decreased than elastic mood. Of course, the fixation hypothesis of the stripe section surface in the plasticity area due to the plate thinness is correct in the whole relations of the uniaxial strain in E from E_t was used.

If the degree of strain is specified from the beginning plasticity to the plate fault with σ_p , the buckling is being introduced in the directions of X and Y as following:

$$(17) \sigma_u = \sigma_e + \sigma_p$$

$$(18) \varepsilon_{xp} = \frac{(1+\nu)}{E} \times \tau_{cr} + \frac{\beta\sigma_e}{E} + \frac{\sigma_p}{E_t}$$

$$(19) \varepsilon_{yp} = -\frac{(1+\nu)}{E} \times \tau_{cr} - \nu' \frac{\beta\sigma_e}{E} - \nu' \frac{\sigma_p}{E_t}$$

The negative sign in the buckling means the proportional length reduction.

The shear buckling and displacement reaching to the panel become to the fault tension or equal with the same tension:

$$(20) \gamma_p = \frac{2(1+\nu)}{E} \times \tau_{cr} + (1+\nu) \left(\frac{\beta\sigma_e}{E} + \frac{\sigma_p}{E_t} \right)$$

$$(21) U_p = \left(\frac{\tau_{cr}}{G} + (1+\nu) \left(\frac{\beta\sigma_e}{E} + \frac{\sigma_p}{E_t} \right) \right) \times h$$

The panel degree resistance will be governed as following with the same yield point:

$$(22) F_p = (\tau_{cr} + 1/2\sigma_u \sin 2\theta)bt$$

Now, it can be determined the division of the ultimate shear resistance on displacement in the panel shear stiffness.

$$(23) K_E = \frac{bt(\tau_{cr} + 1/2\sigma_e \sin 2\theta)}{\left[\frac{\tau_{cr}}{G} + (1+\nu) \left(\frac{\beta\sigma_e}{E} \right) \right] \times h}$$

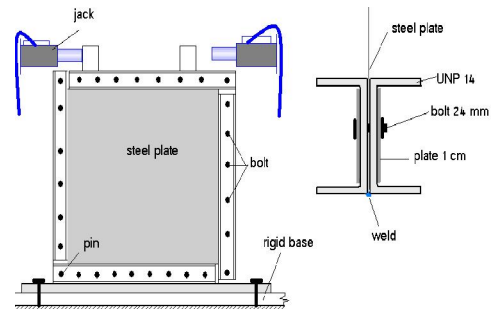
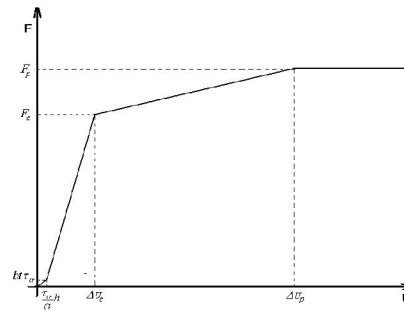

Figure 4. The behavior of steel shear wall panel

3. The study of theoretic discussion with experimental results

Six samples of steel joint shear walls with different dimensions and thickness were given in table 1. To study the seismic respond and its different effects, these samples were evaluated. The loading of these samples was achieved by jacks which are shown in figure “5”.



Figure 5. The establishment of the samples in a cyclic experiment completion

Table 1. The specifications of the samples in a cyclic experiment

ERROR(MM)	U _E (MM)	F _E KGF	(KG/CM ²) τ_{cr}	F _Y (KG/CM ²)	T(CM)	H	B(CM)	THE NAME OF SAMPLE
2.5	17.5	8583	10.27	2663	0.07	92	92	307
0.1	14.1	10524	20	2283	0.1	92	92	308
0.2	24.78	7836	7.34	2663	0.07	142	92	309
1.9	22	9619	15	2283	0.1	142	92	310
0	17.5	13894	6.55	2663	0.07	92	142	311
0	14.2	17031	13.4	2283	0.1	92	142	312

The figure 6 and 7 have given the placement-load coordination comparison and their theoretical relations. It's obvious that the degree of panel shear resistance in yield point (Fe) has difference with hysteresis coordination in relation 15. That is, in panels with equal threshold width (b) but different heights (h) are different before the buckling (T_{cr}) but equal after any bucklings. Of course, the relations do not have any impact but it does not seem logically that the panel with width 3^m and height 1^m have not any difference with the same panel dimensions. Hence, to verify the related degree, a correction coefficient, samples with b/h proportions were modeled in ABAQUS software.

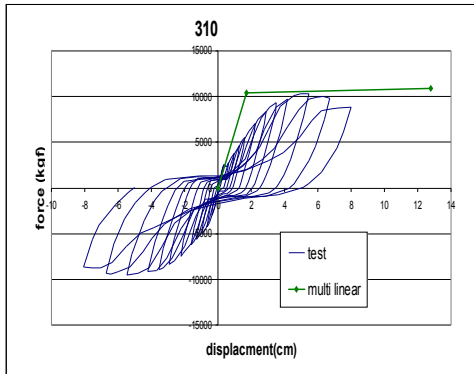

Figure 6. The comparison of placement-loading theory and sample hysteresis coordination 309

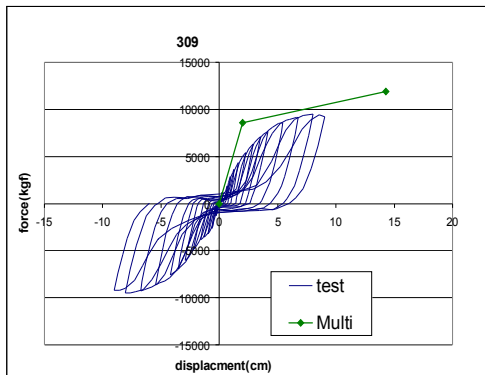

Figure 7. The comparison of placement-loading theory and sample hysteresis coordination 310

4 – The modeling of restricted elements in steel shear wall and accurate measurement with experimental results:

To study the behavior of steel shear wall wreckage, having a suitable mathematic model is required according to the engineering abilities with restricted element method which is mostly based on ABAQUS software.

Modeling hypothesis:

- 1) The thickness and width of the panel is fixed.
- 2) The lower column is completely motionless and shear is forced to the upper column.
- 3) The restricted elements of cross-sections are hardly to be observed and the connected points are completely joint and no bear any tensile anchorage.
- 4) The shear is not tolerated the plate
- 5) The lateral restricted elements buckling are negligible.
- 6) Meshing for every model is achieved up to the recovery results considerably.
- 7) To study the behavior after steel wall buckling, are-length method is used for solving non-linear equations.

Because the model is composed of Elastoplastic material, the tensile and buckling is considered as two linears. The analysis of each sample is consisted of two buckling linear and non-linear dimensions after buckling. Hence, sampling has two files. The first file including buckling analysis which is aimed to change the sample buckling formations for buckling moods, which is being used for the first imperfection of post-buckling. For the first buckling, the linear Static Buckle has been applied but for the second post-buckling, the non-linear static risk analysis has been used efficiently.

Since, the results of restricted element method should be confirmed to the experimental results, hence, the samples of 308,310, 312 given in table 1 were used. All these three samples were modeled with the same geometrical and material specification in ABAQUS software. The figures 8 to 10 have shown the comparison of the obtained results from the analysis of restricted element and experimental results. The comparison of placement-load

coordination from restricted element modeling using ABAQUS software with hysteresis coordinations show that the restricted element modeling with ABAQUS software has an accurate precision due to an accurate modeling using ABAQUS software along with parametrical studies on the effect of height to threshold changes and steel shear wall resistance which is the main aim of the study in this regard.

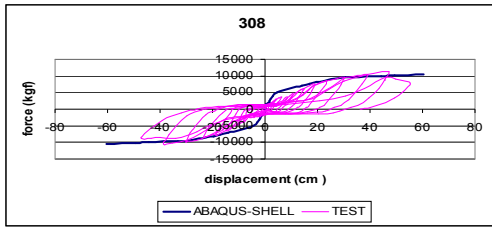

Figure 8. The comparison of experiment coordination and computer-based models in sample 308.

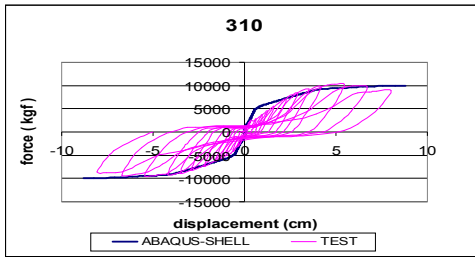

Figure 9. The comparison of experiment coordination and computer-based models in sample 310

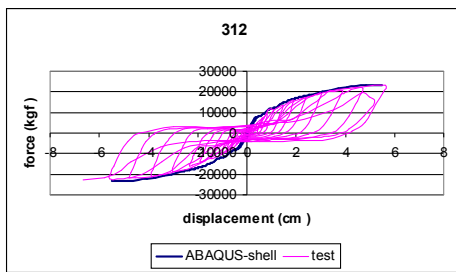

Figure 10. The comparison of experiment coordination and computer-based models in sample 312

5) The study of b/h proportion effect on the steel shear walls resistance:

In all samples, the geometrical can material specifications except the height are equal. The specifications have given in table 2.

Table 2. Geometrical specifications

Row	Sample	b(cm)	h(cm)	t(cm)
1	F	400	200	0.07
2	G	400	300	0.07
3	H	400	400	0.07
4	I	400	500	0.07
5	M	400	600	0.07

Also, the material specifications are as following:

$$E = 2 \times 10^6 \frac{kg}{cm^2}$$

$$V = 0.29$$

$$F_y = 2400 \frac{kg}{cm^2}$$

After modeling the samples by the use of placement-load coordination in figure 11, it seems that the degree of panel shear resistance in the yield point can be governed for each samples and then based on table 3, the K coefficients will be obtained for different b/h proportions.

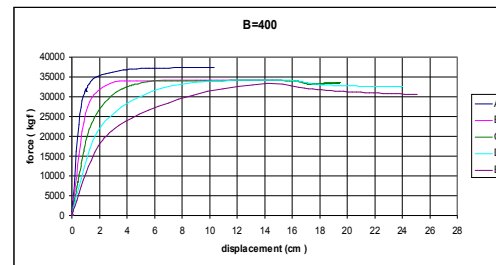
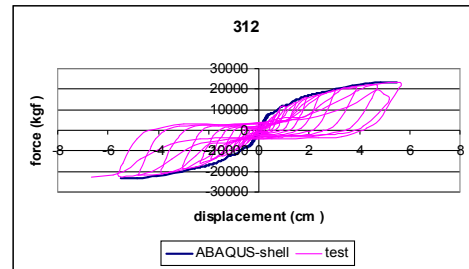

Figure 11. The coordination of placement-load in modeling

Table 3. The degree of K coefficient

Row	Sample	b/h	F	K
1	A	2	21500	1.053
2	B	1.33	21000	1.028
3	C	1	20416	1
4	D	0.8	17500	0.857
5	E	0.66	15000	0.734

Note: the degree of (k) has been obtained by diving the shear resistance in each panel in panel shear resistance with b/h=1 proportion. Now, using the (b/h) proportion, and the measured degree of (k), the coordination b/h on k degree in figure 12 is being plotted.

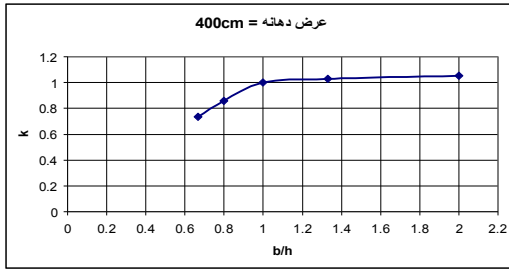

Figure 12. The coordination of b/h proportion with k

According to above coordination, the two linear equation can be measured: one for $b/h \leq 1$ and the other $b/h \geq 1$ equal to one and it can be neglected, too.

Table 4. The study of K coefficient functions in theoretical relations

Sample	b (cm)	h (cm)	t (cm)	b/h	k	Fe* k (kgf)	Fe (kgf)	Ue (cm)	Fp (kgf)	Up (cm)
309	92	142	0.07	0.64	0.71	6097	8565	1.99	11914	14.3
310	92	142	0.1	0.64	0.71	7384	10400	1.7	10891	12.78

By using the degrees of table 4, the placement-load coordination will be plotted for each of these samples with K coefficient and without coefficient again. The figures 13 and 14, the comparison of experiment hysteresis with placement-load theory with and without coefficients were shown in samples 309 and 301.

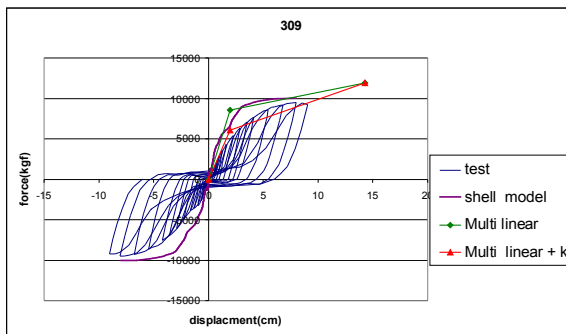

Figure 13. The comparison of experiment hysteresis coordination with placement-load theory with and without K coefficients in sample 309

(24) If $b/h \geq 1$, then k equals to $K = 0.053x + 0.947$

(25) But, if $b/h \leq 1$, then $K = 0.79x + 0.2$

Note, in above-mentioned relations, the degree of $x = b/h$.

By using equations 24, 25, the degree of K can be measured and (Fe) relation is verified as well.

The equation 26 is the verified (Fe).

$$(26) F_e = (\tau_{cr} + 1/2\sigma_t k \sin 2\theta)bt$$

6. the study of equation precision

To be ensure of measured K equation precision and Fe for samples 309 and 310, again the K coefficient and without it will calculated.

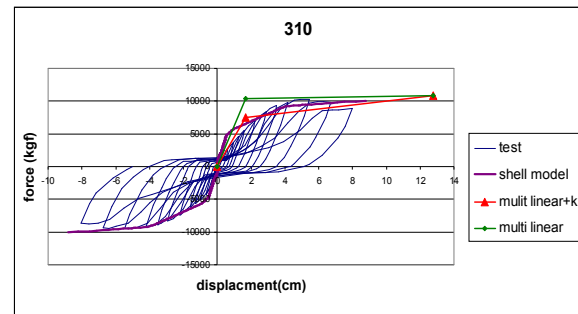

Figure 14. The comparison of experiment hysteresis coordination with placement-load theory with and without K coefficients in sample 310.

Summery and conclusion:

- 1) Generally, the achieved modeling by shell element had a suitable convergence with the real behavior of steel sheets in experimental samples which are a simple mood of steel shear wall of one floor and one threshold.
- 2) One of the most important obtained results as the main purpose of the study is the study of the extraction of a relationship for coefficient functions to given theoretic relations considering the (b/h) effect which is the same height to width proportion on the resistance as following:
If $b/h \geq 1 = K$ and $b/h \leq 1 = K$ then, the above-mentioned theoretic behavior and experimental behavior will get closer

together considerably ensuring the obtained results of theoretic relations.

- 3) In this research, it seems that if the (b/h) proportion is lower than 1, the panel resistance will be considerably decreased which is not favorable behavior in this regard. For example, in the modeling sample with $b/h=0.66$, the resistance decrease will be 27%. As a result, it seems that achieving this system with $b/h > 1$ will be suitable according to the planes dimensions.

References:

1. Veladi, Hedayat, Sazeghari, Arash Javid Saber. 2008. The theoretical and experimental study of steel shear wall. The 4th national conference of civil-engineering, Tehran University, 2008.
2. Khoshkhouy, Amir. The theoretical study and the effect of restricted elements in the height to threshold changes on the steel shear wall. A thesis for M.A, civil engineering group engineers, Islamic Azad University, Mahabad branch, Iran, 2009.
3. Sabouri, Saeed. The resistant systems against lateral or cross sectional loads. An introduction to steel shear walls. Anghizeh publication, 2001.
Jeffrey Berman, M.ASCE, and Michel Bruneau, M.ASCE. 2003. Plastic Analysis and Design of Steel Plate Shear Walls. Journal of Structural Engineering, Vol. 129, No. 11, November 1.
4. Mohamed Elgaaly, 1998. Thin steel plate shear walls behavior and analysis. Thin-Walled Structures 32 (1998) 151–180.
5. Veladi H., Armaghani A., Davaran A. 2007. Experimental investigation on cyclic behavior of steel shear walls. Asian J. of Civil Eng., 8(1): 63-75.
6. Saeid Sabouri-Ghomi; Carlos E. Ventura, M.ASCE; and Mehdi H. K. Kharrazi, M.ASCE, 2005. Shear Analysis and Design of Ductile Steel Plate Walls. Journal of structural engineering © ASCE / JUNE.
7. Wagner and W. Ballerstedt. 1935. Tension fields in originality curved, then sheets during sharing stresses, NCA.
8. Astaneh-Asl. 2000. Steel plate shear walls. US. -Japan workshop on seismic fracture issues in steel structure February. San Francisco.
9. S.Tyan Chen, Van Jeng. 2001. Seismic Assessment and Strengthening Method of Existing RC Buildings in Response to Code Revision” Earthquake Engineering and Engineering Seismology 67Volume 3, Number 1, March 2001, pp. 67–77.

11/16/2012

The pathology of family the dimension of economy with belief approach

Asghar Abedzadeh

Department of Islamic Knowledge, Tabriz branch, Islamic Azad University, Tabriz, Iran

Abstract: The family has been considered as the regular base of kindness and tenderness of human's internal and external necessities which are formed by the marriage. The marriage is a fresh word that strange man and woman make their bond together as a balance which is not completed without each other and the balance is their basic and contrary way to survive in this way. The holy Quran describes the common life as a "heavy and strong bond" happening between two sides which they promise together by the name of God together forever finding their comfortable life time easily. However, it is sometimes observed that the first basic love get lost for making its own foundation. These family pathological affairs are subjected to pre-marriage, during-marriage and post-marriage. Factors like the lack of familiarity, belief affairs, social, scientific, cultural, economical which bringing the process of divorce awfully. All societies try to prevent these kinds of drastically events. Many books and articles have been written in this case trying to discover or make a solution for these pitfalls. The present article is to find a way to clarify many different approaches in this regard. These family pathological issues are beyond of these written articles here but due to the context of the study, the writer of the article tries to point to one of these biggest problems as the mother of the catastrophic events with belief approach here. Among these factors, the issue of economic and finance exists into the families and internal beliefs play key role in arranging economical and financial as well as poverty.

[Asghar Abedzadeh. **The pathology of family the dimension of economy with belief approach.** *Life Sci J* 2012;9(4):3641-3647]. (ISSN: 1097-8135). <http://www.lifesciencesite.com>. 539

Key words: marriage, family, pathology, poverty, unemployment, divorce.

1. Introduction

Of the God's signs is that, he created a mate for you from the same kind to be your comfortness rekindling the whole life time and made friendship among you as well (Roum: 21). Appreciate the God with his omnipotent power whose eternity power is the whole existences sources. And the man whose majesty creature on the land bringing the light of creation and salute Mohammad (peace be upon him) as the most sophisticated man on the earth who made his lovely efforts in publishing the God's divine and religion and chosen successors who are the outstanding pious men as the stable pattern of morality affairs. The family is a fundamental foundation which is being formed by two man and woman sides. Then, with appearing the first child in a family, the roots of the family become stronger and only the death can separate this family bond together. The natural and common form of family separation is the same death, not other factors. The bond of marriage is called a stronger form getting stable than any other bonds among couples (Nesa: 20). The marriage is not a bond between both man and woman, but also the couples make and promise their God in this regard, following the God's orders (Imam Khomeini). Women and men (the couples) have made a strong bond to continue their life time and if they want their child to be profitable in a community, find the joy having better life patterns, they should

stick with their marriage bond. The society's advisors tried to keep the bond strongly but some factors struggling to detach the bond. So, there must be some questions in this case: why some families can spend happy times while others cannot reach to enjoy their life time? How some families can spend their lifetimes in spite of being poor or having chronic disease but others with enough financial and facilities cannot spare their enjoys with other family members. Are really the marriage problems unsolvable? What injuries can hit families separating them?

This catastrophic event exists everywhere in the world and does not belong to a particular class! This also can be formed in different ways in every family. The cultural, social, religious, moral and economical damages can be take place in every family. However, the most crucial issue is to find better solutions for these problems. The main aim of the study is to discover the dimension of economy efficiently applicable for families. Although, the problems existed from the beginning of every family, but there were offered some remedial approaches to solve these problems. Of course, many articles and papers have been also written in this regard, but they were not sufficiently useful to prevent the related pitfalls so far. Thus, it is necessary for everyone to try to cope with these problems following the happiness and bringing into families.

How dramatic a child's appearance in front of family's separation but how satisfactory a child's face being full of smiles with family's happy times?

We are alive and kicking hopefully the dawn of families happiness at their survive on the earth.

Saadia, a good man never dies, dead one is the one whose names dies (Saadi).

2. What is family?

The man congenitally needs to live in a community based on his or her created instincts and common-sense basically. The family can be considered as a small community in versus big community being essential role in social life. At first glance, we figure out that couples based on their religious and moral affairs have made their first bond as a marriage form in a society. Are these factors making the foundation of a family?

There are families who force their daughters to get marry rich people and others may prefer their daughter to get marry a boy for his father's heritage which is not logically implied. The social situations and positions are those factors hiding the unsuccessful marriages into itself. Therefore, the only purpose of the marriage cannot be described in these factors. If the family-making process is going to be based on these affairs, the continuation of the same family will be based on changeable issues because nobody can get into the same conditions of economy and social positions. In addition, the man never stays in the same sexual and instinct position. The male and female are in the climax of their first days of marriage being decreased gradually which they will need each other at their old days and they will enjoy their family foundation at those times, and this is one of the secrets of the marriage. Because, at these periods, the love and kind of couples get into deep relationship sharing their sad and happiness together and they never find the joy without each other: he is the God who has brought the relaxation and confortness into the heart of pious people. (Fath: 4). As the man needs food and gets relaxed after coping with his thirsty and hunger, the couples also need each other when they reach together. The family is an environment where they can find and absorb the care of tenderness filling the gap between family spirits. This is the same issue where they were created. If it does not exist, it is the man's fault not to be able to find his surrounding getting relaxed. They are mostly accustomed of the majority than the reunification of the God (Beheshti).

2.1. The successful criteria of family-making:

If we wish a successful family, there must be indices or factors which couples, big and small have

confirmed them as well. Religious beliefs, being rich financially and scientifically, and touches are those factors bringing happiness, continuation of life and wealth but there are other related-based factors as following:

Knowing both sides together: the first care of family is based on couples who they should know each other sufficiently. However, there are some young people who begin their life relying on the dreams of love but never getting their parties at all which they will be broken down by the same love. They firstly believed that the love is the purest factors of successful criteria in family-making process but they never knew that:

Those loves being as color

Were not loves but fires

Therefore, those marriages without any side's recognition, would be destroyed people's possessions and life territories as soon as possible.

1- Keeping marriage relations:

The marriage is a different event than other ones. When problems and misunderstanding are being appeared, the couples forget the positive and negative remarks of themselves and their common-life way get under suspicions. The continuation of the first life with love is hard but it must be followed with another extra fulfilling love bilaterally. In this kind of love, the issues of sacrifice, forgiveness, virtue and good-tempered affairs are essential factors between couples, to make the strongest relationships together. The couples confront with many big and small challenges and decisions every time: Sharing tasks, expenditures, social activates, entertainment, housing, children nurture, optimizing daily chores and making family virtue.

2- Balancing expectations:

Friends, classmates, neighbors, families and relatives and finally couples expect each other in a family atmosphere. And this is the obvious that there are some impossible ways to compensate problems making a kind of friction among any family relations. These expectations should be in a restricted extent to meet both sides balanced.

The power of economical, social, political, cultural, moral, physical and spiritual affairs must be considered carefully in this process. The couples can themselves make their own adaptations with any hard circumstance. These couples can think of their own realism imaginations to adapt and reach their wishes and hopes successfully. They can also think

about their own common-life sweatness when any sadness appearing in their life time.

They can apply the words, "Goodness knows", replacing the "must" word. This does not mean to forget the lawful right of couples.

3- Belief adaption:

The recognition and believe in God and any tendency toward theological affairs are the man's mother-born instinct which the versus of fitrat pointing to this:

But there may be some factors weakening the belief causing to darkness of realities. Thus, different religious were appeared with different titles gathering few other religious bases towards themselves. Hence, different belief emerges in this regard. The couples will lose in their life without the consideration of these common belief adaptations: "never marry religiousless woman unless they learn the belief..... and never let your daughters marry piousless men (baqhareh:221). In another versus, the god says:"

2.2. Familiarity with tasks

In a small community like family, each member should get familiar with his or her own tasks and duties trying to complete it successfully. This makes responsibility of members high satisfying other family members as well.

The holy Quran says in this case:

"The men are the women's anchor, because the God has made some people prior than others (Nesa: 34).

Based on this verse, virtue and life expenditures have been put into the man's responsibility and the man must get familiar with his own granted responsibility to do it carefully without any reluctance for their own family members.

In other verse:" treat your wives carefully and friendly" (Nesa: 19).

Good morality and good-temperedness of a man with his woman is one of the most common features making a strong bond between the family members. In contrast, the woman of the family is a kind of relief having other task-based duties. If the man tries out to make money, the comfortness is also being the women responsibility to keep family comfort. This task is hidden into women as an artistic work at home surrounding.

Imam Mousa Kazem says: "the challenge of woman is a good-husbanding issue" (Tabatabaiee). The good-husbanding means a good relationship

between the members of a family providing a better background for men activities out of any family chaos.

This kind of task-based responsibilities, the life becomes sweeter among the whole members.

3. Challenging problems

The contraction of marriage is a combination of lawful, religious, emotional and sensitive relationship in a complex path of couples leading to the continuation of the life in despite of family different problems. Of course, the lack of understanding between couples makes them not to pay attention to other issues and these kinds of expectations lead to the lack of family tendency friendly. They never listen to each other statements facing with lots of problems even at their thinking ways. Any problems and difficulties are the sweatness of the life. "The value of health can be understood by the one who experienced catastrophic events."

Let's consider a bumpy road where it can be beneficial even for both driver and passengers, some psychologists believe that a few challenges happening between couples can be profitable recovering the path of life from boring times and removing any obsessions from the hearts of the family members easily. It also provides better background for cooperation among the family members (Beheshti). Nobody is complete but prophets; therefore, the possibility of family quarrels can be emerged in every family. The important key is to find the problem trying to remove it easily.

3.1. Possible injuries in losing families:

The marriage has been considered as a good function among the humanities during the history and has found a great establishment for itself which many books have been written in this regard so far. Although all humans have a good figure of the marriage, but in reverse, they hate the word, "divorce". Although the beginning days of the common life is the basic foundation for meeting all biological, mental and social needs, but some of these marriages cannot be conducted in an appropriate way due to some reasons.

They may face with the word, divorce leading to separate each other immediately.

The individuals motivations are not the same in the process of marriage, and these motivational events are mostly subjected to their internal affairs. Thus, some of these motivations face with failed life realities due to their misadaptations.

Some wishes and hopes were the paths of attraction and flexibility but because of some destroying factors turned to the agent of separation.

In today's word, there are some people making new-family with lots of hopes and wishes but then they decide to stop their marriage for happening events saying: "spit on these bad-hearted people who destroyed our happiness mocking at our parent's tears."

So, it is necessary to take this problem into troubleshooting pathologically to find out its cause and effect.

3.2. Family pathology in terms of economical dimension

The issue of economy can be discussed in two sections. First, the boys and girls or their parents accept the process of marriage for family richness and do not know other fundamental basics in the marriage which finally leading families towards failure.

The magazine's event column and other judiciary samples are the best examples of family failures and their statements about this calamity saying: o, what a pity chance, no wise mind causing to terrible events!

The financial issues cannot be forgotten among families and the man of the family responsible for providing all necessary requirements but he should not be considered as the cause of common life. The attractions, emotions, tenders, sacrifices and good tempers are the necessary non-material resources should be sought through spiritual affairs. Imam Ali says that, if one of your brothers got wealth and rich or a good wife, never be jealous of him...

As the wealth and children are the world's transient possessions and being destroyed and good actions are the resurrection's cultivation although the God sometimes forgives both of them to the nations on the land (Dashti).

Second, the existed poverty into families may destroy or separate relations of families and this is one of the most essential damages in a community which most families confront it daily. The poverty is the biggest social turmoil in higher levels where threatening many families. It is also considered as the common gap among families. Imam Ali says in Nahjolbalaghe:

To be wealth is like being in a land but to be poor is like being in a land as stranger (Hekmat: 56). In these days decorative world, the values have been combined with belongings, wealth, positions and social situations. Now, how it can be expected the poverty is not the serious threat for families?!

The poverty is considered as the greatest death and rejection agent in religious texts. As the holy prophet says: "the poverty is about to bring the blasphemy (Abedzade et al). As it shown that the

poverty is the agent of blasphemy and it is the factor of irresponsibility and bad-temperedness into the families. Imam Ali says: the poverty is the greatest spiritual death. (Hekmat: 163)

The poor man is sad and depressed trying to compensate his or her deficiencies by doing every action:

Takes dirty money, steal, commit crimes and oppresses other rights.

Of course, the poverty is not the entrance of doing criminal actions. Some of these poor people have high confidence which many rich people exaggerate them but they can say something among these actions why doing these criminals?! For the reason, the great people have suggested to prevent doing these awful actions. As Imam Ali says to his son, Mohammad Hanfieh: you, my lovely son, get under protection of the God from any poverty (I am afraid of your poverty), which the poverty loses the man's belief and the agent of refugee and enmity. (The anger and fury motivation factor) (Nahj-olbalagheh).

In a society where people get poor doing actions to meet their needs which are unexpected actions:

Stumbling in belief is the born of poverty
Unless the man is not born robbery

As it described, the economical issue plays a key role in paid attention efficiently. However, in despite of these challenging debates, what remedial approaches are valuable to stop these actions.

The poverty causes and effects:

The happened poverty into families may have ten internal and external reasons which is beyond of the study here. Therefore, according to Imam Ali:

Unemployment, mis-thinking in family affairs, being lavish, making clean or dirty earnings, the lack of correct preservice of possession, relationship with gangs are the destroying factors of human's spiritual issues.

Imam Ali says in this case:

As the mighty God has given the people's belongings into rich people. Then, no any poor people left on the land except rich people's happiness and the God will ask about their hunger (poor people) from rich ones! (Nahjolbalaghe).

If these rich people obey what the God orders religiously and give or share their possessions with poor people for the sake of God and if they pay fairly employers rights and salaries, these poor individuals certainly will be conducted in a correct path of life getting rid of poverty. But unfortunately it is observed that these rich people never think of weak financial people. The poverty cries it is poor situation

being ashamed of the family. In turn, there are rich people who are enriched of material things without considering around themselves spending their times comfortably. They mostly label themselves as Muslims: the last majesty prophet says:” everyone spending times without thinking of other Muslims is not Muslim (Nahjolbalagheh). So, these people must appreciate the God for all these galore endowments paying attention to poor people as well. There will be an approaching day which these rich people were being asked and penitence would be impossible.

4. Unemployment as another agent of family failure

Today, the most common problem of the communities is the Unemployment among the adolescents. These youngsters should work with their own abilities and meritness along with property, because the work is the origin of every man. The lowest continues work is also useful and hopeful for the family members making their spirits joyful. The little thing or action being completed with high happiness can be useful (Nahjolbalagheh). In the religion of Islam, an employment youngster has been blamed. The scientists have applied different description for the process of job but socially, the job means doing or completing something applicable or useful for reaching to the main purpose of the man. The municipality maker, building engineer, nature pointer, local shoe-maker are bearing troubles and following targets after finishing up their work. The allowed works getting done by someone to provide his or her daily needs have been considered as worshiping issue; so, the job is the worship. Any struggles or strives have been called Jihad in the pavement of the life:

The origin of Islam has seriously fought against any unemployment considering poverty as the source of miserable and sadness. It is quoted that when the holy verses of the one who takes piety, the God opens the doors for him raising belongings (Talagh: 2) was descended, some people left their jobs started worshiping. The message reached to the holy prophet and he asked them to say why they left the job and only worshiping?! They replied that the God guaranteed them to send sustenance by the verse he descended. The holy prophet vigorously punished them and said that,” those ones who taking this kind of action leaving his job, the prayers will not be accepted. The cleanest food which the man eats is the food that the man has earned them through his own efforts (Sahafi). The method and way of Islamic leaders are the authentic documents for the fact that the religion of Islam not only raises the man’s futurity happiness, but also it makes nations to be

honored of their actions. The holy prophet of Islam as the selected man of the creation himself worked as a shepherd or Imam Ali as the first shiiat Imam worked in the field of gardening and cultivation. Other saints were also working at their own era.

An Islamic young is not allowed to be unemployment. The holy prophet said: the one who is boring in his or her daily affairs, he or she will be bored in the futurity (Sahafi). The best Muslim is not the person who forgets his futurity but the person who profits his world is the best Muslim in this regard. The religion of Islam is a saint and realism based religion which considers the wealth, spiritual facts, the world, the futurity, forms and features and the creator and creature. The man who not working and being slack at job atmosphere following criminal actions would be destroyed in terms of spiritual affairs making hooliganism community.

4.1. The consequence of poverty and unemployment

The poverty is the born of unemployment making any family foundations destroyed which we will point to some of these wrecking factors here as following:

Case of weakening belief

The poor person who is suffering from the hunger, cannot understand what belief is and he is not expected to be able to raise or preserve his or her belief. Imam Ali says to his son, Mohammad Hanfieh: you, my son, I am afraid of your poverty (Nahjolbalagheh). What mostly connects family together is the beliefs and religious faiths which their destructions make people or family members separated, leading to the drastical events, divorce. As Imam Ali said the poverty causes to disruption of wisdom. In the other words, the lack of the wisdom can conduct doing wrong or criminal actions making a person’s intellect puzzled. His decisions get hostility, his anger becomes lot and boring is overcoming on that person, and being challenged to family members.

4.2. The feeling of solitude

The poor person is always alone because others are away that one. Of course, this is none of other poor people because they are considered as people themselves. Their relations are weak:

Poverty makes the man nimble and the poor person is stranger in his own homeland (Nahjolbalagheh)

No one makes friendship with others
Unless someone’s market is hottest

The poverty in homeland is strange (Nahjolbalagheh).

The unemployment and poor individuals feel ashamed and annoyed of their surroundings. Living away is the most common behavior of poor people. Others cannot help these people due to some reasons. This kind of solitude is getting increased leading to bad-temper and misbehavior. In terms of psychological theories, no way for family adaption but there may be some factor for the family separation.

4.3. Remedy

If the issue of economy is going to be a family problem and damage, and if other damages such as unemployment make separation among family members, so, what remedies we can introduce to prohibit these injuries? Every problem can be solved by an approach. If the poverty and unemployment make family detachment, there must be some remedial approaches to stop the publication of this catastrophic problem. Making job and occupational opportunities are the best remedial approaches in this regard. The statistics indicated that most criminal actions have originated from the unemployment of issues. Moreover, every society struggles to get rid of these calamities. Thus, it is public responsibility to do these following choices for stopping the poverty:

A – The government:

It is basically stated that the sufferings of people to be hard for the government. The government as the greatest source of people origins to help and assist their problems plays a key role in removing social problems which the unemployment is one of these essential pitfalls. The different governments of the world are facing with this issue but the roots of the problem have not been eradicated yet. The government cannot prescribe a cohesive approach to prevent the problem of unemployment. In the other hand, the economical and social issues require their own particular situation and people expectation is not negligible in this regard. Therefore, firstly, the government should have the number of unemployed people. Secondly, it should make familiar with the culture of work. Probably, people think of seating behind the tables can be considered as a great occupational opportunity, but it is a common wrong idea these days. Thirdly, these job opportunities should be positioned based on required locations in the country. This makes people more responsible. Fourth, the problem of unemployment and it is consequences should be urgently published among people. Fifth, people should believe their government is with them supporting the present status.

B – Nations: the government is like the nation and government which does not belong to nations would failure in its own planning's in future. However, these days both nations and government make themselves united according to organizational charts to fulfill their own targets successfully. The nations as the regular base of the government's basics must think of their own social problems as well. The poverty is of a social consequence challenging the whole social events drastically. So, it is necessary for people to do:

First, make themselves as responsible for eradicating basic problem. Second, the rich people take poor people as their own success agent. Third, they should endure in their problems trying to solve them efficiently.

Imam Ali says: "step into a correct way because it gives you honorable personality preventing any punishes" (Gararolhekam).

Fourth, be hastily in workers payment and never pay one penny lower.

The holy prophet says: "the one who pays worker's payment low, the God rejects his action being prevented of the smell of the paradise" (Nahjolbalaghe). And some other options expect people to make their best struggles for the prevention of the poverty and unemployment.

5. Results

The marriage is an instinct phenomenon and family-making is the rights of man and woman. The family is the core of friendship and tenderness which connecting for away strangers close together. The couples make promise their God at first days of their life. However, it is dramatic to see the couple's sadness appearance in this regard. Some families spend the sweetest and precious golden times together. In contrast, other families may suffer from some problematic issues in their life time. The love before and during the marriage sometimes becomes disappeared and fed up and the process will be different due to some cultural, social, scientific and economical status. The only common and shared issue is the economical status in the humanity communities. The poverty and unemployment are two related words together in the family failures. The social on the high-potential struggles eradicating the roots of poverty and unemployment. The attention to Quranic verses in the field of job government and nation's significance clarifies the people and government tasks clearly. According to these holy verses, the problems can be solved easily.

We are hopefully wishing a day out of any humanity oppression, poverty and unemployment. We again hope all people get under the flag of

unification having family happiness with full of smiles on the lips.

References

1. Holy Quran
2. Aroun, T. beck, "love is not enough", translated by Mehdi Gharechedaghi, Zehnaviz publication, 2009.
3. Imam Khomeini, the modern thesis, volume 3, translated by: abdolkarim Biazar Shiraziee, Anjam-e-ketab institute, Tehran, 1985.
4. Beheshti, Ahmad, the family in the perspective of holy Quran, Bustan ketab, Qom. 2007.
5. Payandeh, Abolghsem (translator), Nahjol Fesaheh, Javidan publication organization, Tehran, 1984.
6. Dashti, Mohammad, the translation of Nahjolbalagheh. Amir Almomenin cultural institute, 1999.
7. Sahafi, Seyed Mohammad, "Islamic thoughts", Ahlebeyt publication office, Qom, 1988.
8. Abedzade, Asghar and etal, Islamic morality. The group of authors, Tabriz, 2007.
9. Fasafi, Mohammadtaghi, the philosophical speech of the youth", volumes 1, 2, 15th printing, the office board of Islamic thoughts, Tehran, 1965.
10. Mohaghegh, Mohammadbagher, the couples city rights, Quranic foundation, Tehran, Bita Mousavi, Seyed Akhbar and Samari, Mohammad," the familiarity of family rights and citizenship," 2nd printing, Ma va Shoma publication, Tehran, 2007.

9/6/2012

Comparison of cardiac structural, functional indices of male elite swimmers and triathletes with non-athletes¹Rasoul HashemKandi Asadi, ¹Mir Hamid Salehian, ¹Jafar Barghi Moghaddam, ²Mehdi Faramoushi

1. Department of Physical Education, Tabriz branch, Islamic Azad University, Tabriz, Iran

Email: R_Hashemkandi@yahoo.com

2. Department of Physical Education, Tabriz Islamic Art University, Tabriz, Iran

Abstract: The purpose of this study was to investigate structural and functional cardiac indices in elite male swimmers and triathletes versus non-athletes. 20 elite male athletes (10 swimmers and 10 triathletes) and 10 healthy non-athletes volunteers participated in this study. Structural and functional cardiac indices measured by two dimensional, M mode and Doppler echocardiography. Data were analyzed by ANOVA, post-hoc Tukey and Pearson' correlation coefficient at significance level 0.05. M-mode and two-dimensional measurements of the right and left ventricular cavity and wall were obtained in elite orienteers and sedentary males. For the right ventricle and wall, multiple cross-sections were used and measurements were obtained from the right ventricular inflow and outflow tract. The results indicated that LVDd was significantly greater in the triathletes compared with the non-athletes ($P < 0.05$). In addition, PW was significantly greater in triathletes compared with the non-athletes ($P < 0.05$). Moreover, LVM was significantly greater in all athletes compared with non-athletes, but athletes have less HR and RPP ($P < 0.05$). However, there weren't significant differences between groups for Q, EF% and FS% ($P > 0.05$). In the end, the results indicated a close linear correlation between LVM with LVD and PW.

[Rasoul HashemKandi Asadi, Mir Hamid Salehian, Jafar Barghi Moghaddam, Mehdi Faramoushi. **Comparison of cardiac structural, functional indices of male elite swimmers and triathletes with non-athletes.** *Life Sci J* 2012;9(4):3648-3651]. (ISSN: 1097-8135). <http://www.lifesciencesite.com>. 540

Key words: cardiac structural, functional indices, elite swimmers, triathletes

1. Introduction

Exercise and physical activity form the part of everyday life for most people. Medical research now suggests that sporting activities in addition to recreational aspects have essential for health and mental relaxation (9). In addition, the study of persistent and hard-working athletes, young athletes compared with elderly one, active patients versus inactive patients can be interesting source of useful and harmful data in the field of sport activates and cardiovascular disorders'. In the case, the heart key role can be inevitable in providing the required needs of body especially physical activities (9). Heart with regular exercise and long-term changes is being distinct from non-athlete heart because of these different changes. The changes and structural adaptations and the performance of the heart in response to the regular exercise is considered as a physiological phenomenon opposed to pathological conditions (1). These changes are mainly happening as an increase of the size, dimensions, the thickness of ventricular wall, diastolic end volume, ejection fraction, stroke volume and decrease of beat and multiplying beat – pressure (RPP) at the rest time. However, the effects of different sport activities depend on the race, heredity, gender, physical fitness, type, severity and duration of the activity (3). Aerobic and endurance activities follow the extrovert hypertrophy patterns through putting overloaded

volume in the heart muscle (cardiac muscle). Athletes participating in this type of end diastolic Volume, have stronger left ventricular mass, larger ventricular capacity and most powerful myocardial contraction (3); While the pattern of changes in the strength or power athletes due to the pressure is as introvert hypertrophic and it is associated with increased ventricular wall thickness that the ventricular cavities and stroke volume never increases (1). However athletes in many sports are usually forced to use a combination of exercises due to the continuum between endurance and strength; triple exercise is as exercises that an athlete regularly and frequently participates in swimming, cycling and running ; according to the results of some studies, the triple exercise with both pressure and volume characteristics may be a combination of hypertrophy pattern (introvert extroverts) (4). However, research results related to the combined effects of exercise on indices of myocardial structure and function, is somewhat contradictory. King et al. (2008) also studied the cardiac changes among elite sailings and found that there is a significant difference between the left ventricular wall thickness, size and end diastolic and systolic volume of the left ventricular cavities in boat-riders and non-athletes (5).

The exercise tests, echo and electrocardiography have used vastly for showing the accurate effects of aerobic and non-aerobic exercises on the athlete's

heart. The information obtained in this manner helps coaches to train athletes who are able to withstand any pressures. Echocardiography is as a non-invasive and safe diagnostic tool for determining the changes and adaptations resulting from exercise in athletes; ; However, few studies have been carried out in this field especially in the new sport fields especially in the new sport fields such as triple sports; therefore, due to the new format of triple sports in Iran, the internal and external contradictory findings and involving different parts of the body in terms of swimming, cycling and running have been found and the present study has been fulfilled as semi-experimental along with structural and functional indices of elite swimmer's heart, swimmers, triathletes and non-athletes.

2. Methods

Among the community of East – Azerbaijan athletes, 20 male elite swimmer and triathletes were voluntarily selected as an available sample; while in control group, 10 healthy non-athletes (with no history of heart problems, cardiovascular or taking regular doses of certain drugs) were chosen. Moreover, none of the subjects of control group had any regular history of exercises or any activity in a certain sport field. (Table 1).

Table 1. personal characteristics of subjects

Measured indices	Swimmers	Triathletes	Control
Age	17.1±0.99	18.7±1.49	19.5±1.08
Height	174.9±5.25	175.7±4.87	172.8±5.05
Weight	64.8±10.03	65.2±4.15	65.5±4.27
Body mass index (BMI)	21.07±3.15	21.11±0.94	22±2.14
Percentage of fat	11.79±1.66	9.91±1.67	19.08±1.96
Surface of body surface (m ²)	1.78±0.16	1.79±0.07	1.77±0.05
Maximal oxygen uptake	50.9±3.25	58.14±4.8	22.95±1.84

2.1. Methods of variables measurement:

The weight and height of the subjects were measured, respectively, by the use of analog scale (with accuracy of 0.1 Kg) and the Japanese standard height gauge (with accuracy of 0.1 mm); then, the body mass index (BMI) using weight (kg) to squared height (meters squared) was calculated. The surface of body surface also using a chart to estimate the total body surface (the diagram of height- weight) was determined per square meter (12). The systolic and diastolic blood pressure of the subjects was measured by the use of measuring and edictal devices, Auscultatory method, 10 to 15 minutes rest time sitting on a chair; To estimate the Maximum oxygen

consumption ($V_{O_{2max}}$) of the subjects, Queen step test was performed after 5minute warming up and stretching the involved muscles (Hamstring, four-headed, twins, Achilles tendon) with metronomy to 96 hit songs (24 steps per minute) on a step height of 41.3 cm. the heart periodical recovery beat of the subjects was recorded five seconds after an aerobic power test as standing mood using a polar heart-rate meter for 15 seconds and multiplied in 4 (heartbeats per minute). Their maximum oxygen consumption also was estimated by the following formula per (ml/kg/ min): (6)

$$\text{Maximal oxygen} = 111.23 - (0.42) \times (\text{recovery of heart rate per number of beats in minute})$$

The percentage of body fat was anticipated by using skin thickness (caliper) and a three-point formula (book of upper arm, abdomen and right perivis) (7).

$$\text{Percentage of} = (0.39287) \times (\text{total of three - points}) - 0.00105 \times (\text{total of three points})^2 + [0.15722 \times (\text{age})] - 5.188$$

The structural indices of End-diastolic posterior wall thickness (PWD), End-systolic posterior wall thickness (PWs), left ventricular systolic dimensions (LVD_d) and left ventricular systolic dimensions (LVD_s), left ventricular mass (LV_m) along with other functional indices and indicators of Ejection fraction (%EF) and fractional shortening percent (%FS) in left ventricle were measured by the use of two-dimensional echocardiography and Doppler with echocardiograph MEGA, Model 2005 made in Italy; then, by the use of following formula, stroke volume (SV), Cardiac output (q), RPP, LVVd and LVVs were estimated.

The research hypotheses using inferential methods were studied in the significance level (> 0.05) which at this stage, the one-way variance analysis test was applied to compare the groups and their differences; In this regard, the post hoc Turkey test was used to find any differences among the groups. Finally, the relationships of some variables using Pearson correlation coefficient and multiple regression were examined.

3. Results

Based on the obtained results, in LVD_d index only significant difference was observed between control group with triple groups and runner, but there is no any significant difference between groups in relation to LVD_s .

In indices of PWD and PWs also observed significant difference between control groups with triple, runner and cyclists groups. Also, in the stroke volume, the only significant difference between groups in relation to LVD_s .

In indices of PWD and PWs also observed significant difference between control groups with triple, runner and cyclists groups. Also, in the stroke volume, the only significant difference was observed between control group with triple and runner groups. In indices of LVm, HR, RPP, there were significant difference between control group and there rest of the groups; but, in cardiac output (Q), there were not observed any significant difference between % EF and % FS. In sport groups, there is only a significant difference in PWD between swimming groups with triple groups and cycling; finally, according to the results of Pearson correlation coefficient that there is a negative significant relationship between the heartbeat with left ventricular dimensions in the end-Diastolic, the thickness of posterior wall in the end-Diastolic, left ventricular mass and stroke volume. These results were reverse in the stroke column size. The following table summarizes the findings of the study as follows:

Table 2. Result of the study

Structural and functional indices of the heart	Fields		
	Swimmers	Triathletes	Non-athletes
(LVDd) (cm ³)	5.11±0.5	5.34±0.35	4.82±0.4
(LVDs) (cm ³)	3.25 ± 0.45	3.54±0.48	3.17±0.21
(PW _d) (cm)	0.94 ± 0.12	1.08±0.1	0.83±0.04
(PW _s) (cm)	1.46 ± 0.28	1.53±0.16	1.09±0.03
(LVM) (gr)	222.9 ± 18.19	266.87±20.75	155.8±21.43
HR	68.4 ± 8.55	66.6±4.37	82.5±4.99
RPP (mmhg*min/b ^p)	8310.8 ± 941.2	8033.2±617.5	10148±838.5
SV (ml)	82.2 ± 6.6	86.1±5.8	65.8±5.8
Q (L/min)	5.6 ± 0.5	5.6±0.3	5.4±0.5
EF (%)	65.4 ± 8.1	62±5.5	60.4±6.7
FS (%)	36.5 ± 6.3	34.1±8.4	33.9±4.9

Based on the results, there is a positive significant relationship between the left ventricular mass with the dimensions of the left end- diastolic and systolic ventricle, and the thickness of posterior wall in the end diastolic and systolic; furthermore, according to the results of the pearson test and multiple regression, the percentage of fat, maximal oxygen consumption and structural variables such as the dimension and left ventricle mass can be measured.

4. Discussion and Conclusion

Based on the results of the present study, the left ventricular end diastolic dimension (LVD_d) was significantly larger in triathletes and runners in the control group (P<0.05). Although cyclists and swimmers also had larger LVD_d than controls but there was no significant difference between them; Also, between the different sport fields no any significant difference found. Due to the distribution of the groups and athletes of four sport fields who participated in the present study, the findings cannot be blamed entirely for or against previous researches'. However, most previous research also pointed to the significance difference of LVD_d among endurance athletes and non- athletes. It can be stated that, although taller and muscular athletes are stronger than nonathletic individuals, but the size of their end diastolic is also larger than usual people; achieving frequent activities cause to an increased diameter and volume of ventricle muscles (2); of course, and increase of the size and left ventricular dimensions has been reported after one week endurance exercise while the cardiac muscle mass indicates while the cardiac muscle mass indicates slower reaction in this regard. The rapid increase if the cardiac sizes is firstly due to the rapid increase of blood and plasma (4). Dynamic movements and isotonic exercises with long- term increase due to the overloaded volume from the volume of high output and left ventricular cavity size (8). The hemodynamic changes and loads imposed on the ventricle and ventricular hypertrophy. These training stimulus cause to a significant increase in end- diastolic volume which in effect also greatly increases stroke volume (4). In the field of running with severe and high- potential exercises, this increases the dimensions and ventricular volume; in the triple field, the cardiac system to lerate overloaded pattern resulting in the elements of exercise intensity and duration. (1, 9); however, the findings of the present study are not matched with the results of Tosk et al (2009) and persinjin et al (2007) (10, 11); In this regard, the results of the left ventricular end- Diastolic dimensions indicating the lack of significant difference between the related groups. In the thickness of posterior wall in end-diastolic and systolic between control groups with triplets, runners and cyclists, runners and cyclists there were significant differences in which they were larger than control group (P<0.01). The thickness of posterior wall of end- diastolic in swimmers was smaller than triathletes (P<0.05), which it was due to the low age of swimmers. Although swimmers begin their activities earlier than other athletes, the age of selected swimmers was lower than other athletes, too. Of the left ventricular mass that was significantly

lower than athletes, there was no found any significant difference between sport groups. In relation to the performance indicators, the amount of heartbeat and double multiple in sport groups was significantly lower than control group; but in the stroke volume index the only significant difference was observed between the control group and triathletes; but in the cardiac output index, ejection fraction and shortening time between the control group and the athletes no found any significant differences. Long- term exercises increase parasympathetic activity and may decrease the sympathetic activity and also reduces the irritation of the sinus- atrial node that these adaptations are due to the low heart- rate of endurance athletes. (9); this reduction leads to the decrease double multiple imposed pressure into the heart at relaxation time. As the results of the present study showed, the reduction of the cardiac rate is compensated due to the increased stroke volume in which this is very obvious in the fields of running and triple sports. Therefore, it is not unexpected that there is no observed any significant difference in the cardiac output, ejection fraction and shortening time among athletes and non-athletes at relaxation period.

According to the results of the present study and previous researches, it can be stated that the long-term exercises make a tangible changes in the structure of the heart (cardiac tissue) increasing the left ventricular mass of the athletes. It seems that triathletes have both features of cardiac power and endurance. However, researches related to these kinds of sport field are at the beginning and any definite statements about cardiovascular adaptations depend on many researches.

References:

1. Douglas PS. Cardiac considerations in the triathlete. *Med Sci Sports Exerc.* 1989 Oct;21(5 Suppl):S214-8.
2. D'Andrea A, Caso P, Sarubbi B, Limongelli G, Liccardo B, Cice G, et al. Right ventricular myocardial adaptation to different training protocols in top-level athletes. *Echocardiography.* 2003 May;20(4):329-36.
3. Henriksen E, Sundstedt M, Hedberg P. Left ventricular end-diastolic geometrical adjustments during exercise in endurance athletes. *Clin Physiol Funct Imaging.* 2008 Mar;28(2):76-80.
4. Koc M, Bozkurt A, Akpınar O, Ergen N, Acarturk E. Right and left ventricular adaptation to training determined by conventional echocardiography and tissue Doppler imaging in young endurance athletes. *Acta Cardiol.* 2007 Feb;62(1):13-8.
5. King GJ, Murphy RT, Almontaser I, Bennett K, Ho E, Brown AS. Alterations in myocardial stiffness in elite athletes assessed by a new Doppler index. *Heart.* 2008 Oct;94(10):1323-5.
6. Chatterjee S, Chatterjee P, Mukherjee PS, Bandyopadhyay A. Validity of Queen's College step test for use with young Indian men. *Brit J Sport Med.* 2004 Jun 1;38(3):289-91.
7. Kaminsky LA. ACSM's resource manual for Guidelines for exercise testing and prescription. 5th ed. Baltimore, MD: Lippincott Williams & Wilkins; 2006.
8. D'Andrea A, Caso P, Scarafile R, Salerno G, De Corato G, Mita C, et al. Biventricular myocardial adaptation to different training protocols in competitive master athletes. *Int J Cardiol.* 2007 Feb 14;115(3):342-9.
9. Owen A, Theakston SC, O'Donovan G, Bird SR. Right and left ventricular diastolic function of male endurance athletes. *International Journal of Cardiology.* 2004 Jun;95(2-3):231-5.
10. Teske AJ, Prakken NH, De Boeck BW, Velthuis BK, Martens EP, Doevendans PA, et al. Echocardiographic tissue deformation imaging of right ventricular systolic function in endurance athletes. *Eur Heart J.* 2009 Apr;30(8):969-77.
11. Perseghin G, De Cobelli F, Esposito A, Lattuada G, Terruzzi I, La Torre A, et al. Effect of the sporting discipline on the right and left ventricular morphology and function of elite male track runners: a magnetic resonance imaging and phosphorus 31 spectroscopy study. *Am Heart J.* 2007 Nov;154(5):937-42.

9/6/2012

Ranking Effective Factors on Knowledge Management system in Bonab Islamic Azad University

Behnam Talebi¹, Roghayyeh Rezayi², Khosro Gholizadeh³, Behnam Heidarian⁴, Saeed Zanjani⁵

1. Department of Educational administration , Tabriz Branch, Islamic Azad University, Tabriz, Iran
2. Department of Educational administration, Tabriz Branch, Islamic Azad University, Tabriz, Iran
3. Sama Technical and Vocational Training College, Bonab Branch, Islamic Azad University, Bonab, Iran
4. Department of Management, Bonab Branch, Islamic Azad University, Bonab, Iran
5. Department of industrial management, Tabriz Branch, Islamic Azad University, Tabriz, Iran

Abstract: In industrial economics, organizations create value through saving. Therefore, creating value depended more on industrial competence and capital budgeting; while in knowledge-based economics, the only creating value method is accepting innovation of a business. In these organizations creating value depends on organizational knowledge, innovation process, and intellectual resources and human resources creativity. The sample group for the present research is staffs having BA and higher degree or faculty members of Bonab IAU. For analyzing data gained from the sample, we made use of paired samples average test in order to investigate the existing and favorable situation and also Freidman test to rank effective factors in knowledge management system. The results show that the existing situation of effective factors on implementation of knowledge management system was not at a suitable level and has a significance difference with its favorable level. On the basis of the results gained from Freidman, the priority of effective variables on implementation of knowledge management system was not the similar and the priority of the variables is as follows: human resources, knowledge management strategy, organizational culture, leadership, information technology (IT) strategy and organizational structure.

[Behnam Talebi, Roghayyeh Rezayi, Khosro Gholizadeh, Behnam Heidarian, Saeed Zanjani. **Ranking Effective Factors on Knowledge Management system in Bonab Islamic Azad University.** *Life Sci J* 2012;9(4):3652-3658]. (ISSN: 1097-8135). <http://www.lifesciencesite.com>. 541

Key words: Knowledge Management System Factors, Higher Education

1. Introduction

In current economics the basis for organizational competitiveness ranking is changed from previous tangible and intangible resources to knowledge and on the other hand, informational systems focus from information management to knowledge management. Businesses which can effectively gain the existing knowledge of the organization and make use of it for business, their production and services have proper competitive advantages in the market. Most of their knowledge management is the basis for their work. These days, the organizations which assign competitiveness ranking as their central issues, consider knowledge management as one of the central activities for their activities effectiveness (Talebi and Salimitorkamani, 1998).

Now, many companies and organizations in the world invest on management knowledge. Despite success, some organizations face failure. It seems that a set of conditions, positions and purposeful challenges lead to final success or failure of knowledge management in the organizations. So, to using knowledge as one competitive, strategic advantage and also systematizing the process of knowledge management development, knowing organization's existing situation regarding knowledge

management and determining effective factors is necessary in an organizations' decision making to make use and optimizing knowledge management (Gholipour et al, 2009). Regarding the above mentioned explanations, one of the main concerns of this area is maybe devoted to priority scheduling of effective knowledge management system in order to properly direct physical and human resources in the knowledge management and this concern is investigated in this study in IAU of Bonab.

2. Literature Review

Knowledge consists of formal knowledge, models, rules, programs and procedures and individual's experiences. It also consists of formal knowledge, communicating, position analysis, new solutions' development and doing organizational activities, cultural issues, traditions and values such as organization audience (Watson, 2003). In a general categorizing, knowledge consists of personal and organization knowledge. Personal knowledge is a knowledge existing in people's mind. Organizational knowledge is a knowledge forms by inter-technology communication, sciences, and people in organization (Bhatt, 2001). Organizational knowledge itself consists of tacit and explicit knowledge. Explicit knowledge is an organized knowledge with a fixed content that can be coded, edited and published

through using IT. This knowledge terminologically is placed at the visible upper part of sources iceberg. An example of this knowledge is data basis and manuals in the organizations. Tacit knowledge is at the opposite extreme of explicit knowledge. This knowledge is personal and depends on text and its place is in individual's mind, behavior and understanding. This knowledge forms the bottom of the resources' iceberg of organizational knowledge. People's insight and intuition are the examples of such knowledge in organizations (Duffy, 2000).

According to Holm (2001), knowledge management is using proper information for who needs it and at the time required, helps people to make and distribution knowledge and act upon it (Holm, 2001). Knowledge management is a systematic and integrated management strategy that combines IT with organizational process. Knowledge management is a managerial activity that develops, transmits, stores, and applies knowledge. And also, puts real information at organizations service to react and make proper decisions (Hung et al, 2005).

In a complete definition, knowledge management is a combination of gaining and storing explicit knowledge with intellectual capitals. Dalkir (2005) investigating more than 100 published definitions about knowledge management summarize them in 3 views:

1). Business views: knowledge management is a commercial activity which has two main aspects: considering knowledge element of business activities as an explicit part of business which is reflected in organization's strategy, procedure in all levels and also creating direct relationship between intellectual capitals and business results. Regarding this view, knowledge management is a combined, cooperative approach for creating, capture, organizing, transmission and using organization's intellectual capitals

2). science- based views: knowledge is the main source that enables us act cleverly. Over time, important knowledge converts into other forms (such as book, technology, procedures, and traditions and ...) in the organizations and generally in the society. This conversions of form, leads to improving knowledge and when using properly leads to improving effectiveness. Intellectual knowledge is one of the main factors that enable personal, organizational and social behavior.

3). Process/technology view: is a concept which transforms information into practical knowledge, and with a minimal effort becomes useful for people who can use it (Dalkir, 2005).

3. Knowledge management processes

According to Wiig (1993) three requirements for success in business are: 1).business and customers 2).Resources (human, capital, equipments) 3). Performance capability. The third requirement emphasizes on knowledge management cycle. Knowledge is the main power in the smart creation performance capability with improving knowledge ; we know what to do better. According to Wiig the main purpose of knowledge management is: facilitating creation, storing, sharing and making use of high quality knowledge in order to create organizations which have intellectual performance.

1). Knowledge creation: Knowledge creation points out at the activities ranging from market research to sample groups, surveys, competitive cleverness, data analysis application. Knowledge creation has 5 activities: knowledge capture, knowledge analysis, restructuring, knowledge combining; coding and modeling knowledge; knowledge organizing.

Knowledge capture can happen through R and D projects, individuals' innovations to optimize working styles, experimentation, reasonable discussion about existing knowledge and employing new people. Also, knowledge maybe created through knowledge import (for example: professional knowledge gained from experts and useful guidelines, involving in joint business activities to gain technology or transferring individuals among branches) and finally observing real world (for example: observing the place, observing the process after change starts).

Knowledge analysis consists of extracting knowledge gained from learnt material, summarizing learnt material, diagnosing the relationship among elements of knowledge and the emphasis that extracted materials compatible with real sources meanings. Combining or restructuring knowledge consists of generalizing analyzed material in order to achieve more developed principles, making hypothesis for describing observations, creating compatibility between new and existing knowledge and updating knowledge source with new knowledge coming.

Coding and modeling knowledge consist of how to show existing knowledge in our mind, how to combine knowledge in a coherent model, how to document knowledge in books and guidelines and how to encode it so as to transfer it into knowledge repository. Finally, knowledge is organized for specific applications according to a determined organizational framework. This organizing usually is done through using existing knowledge determination methods and categorizing it.

2). Storing knowledge: storing knowledge is remembering, compiling and putting it into knowledge repository and archiving it. Remembering knowledge means an individual (the knowledge understood by a specific person) saves knowledge or remembers it. Compiling knowledge in a repository means creating a knowledge base based on computer and also encoded knowledge and has the possibility to be saved in organizational memory. Putting knowledge means guarantying that knowledge is a part of business procedures (e.g. adding to procedure guidelines or training courses).

Finally archiving knowledge means creating a systematized scientific library and abolishing out of date or unrelated knowledge from knowledge depository. Examples of organization's knowledge are: intellectual properties, patents, documented knowledge in the form of research reports, technical papers, or hidden knowledge in people's mind but may be extracted and inter into base or knowledge repository. So, organization's valuable knowledge properties is documented in repository or people's mind and therefore is accessible to see and for future use.

3. Sharing knowledge:

Sharing knowledge is coordinating, gathering, accessing and retrieving knowledge. Knowledge coordination usually requires forming cooperation teams to create a communication network in order to understand the point that who knows what? As soon as knowledge resources are recognized, they turn into accessible records for a library or repository in order to facilitating access and further retrieving. Sample groups often form to reach to consensus regarding this issue. Then access and retrieve can be able to consult people about difficult issues, asking related experts' views, or discussing one difficult issue with a same level colleague. Moreover, knowledge can directly accessible and retrievable from a knowledge repository.

Organizations can share knowledge in different ways. The staffs who lack the required knowledge for solving a specific problem can communicate to others who have the similar experience through gaining information from organizational knowledge repository or finding related expert among specified professional network in the organization and directly contact to that person. Then, these staffs can organize all these information, and ask other more experienced staffs verify the content validity.

4. Knowledge use

Knowledge use is doing responsibilities, survey and description, choice, observation, analysis and combining, evaluation, decision making and performance. From knowledge view point, the

resource of competitive advantage is knowledge use rather than knowledge itself. Despite this, organizations often are not enough creative when using knowledge operating methods (Glitch Li, 2009).

Table1. Determining factors in knowledge management and their theorists (Valmohammadi, 2009)

Researchers and Authors	Main Factors	Rows
Skyrme and Amidon (1997), Holsapple and Joshi (2000), Davenport et al (1998), Hassanali (2002), American productivity and quality center (1999), Ribirer and Sitar (2003), Wong and Aspinwall (2005), Albusaidi and Olfam (2005), Chung (2006), Akhavan and Jafari (2006)	Leadership	1
Skyrme and Amidon (1997), Davenport et al (1998), Liebowiz (1999), American productivity and quality center (1999), Mc Dermott and O'Dell (2001), Hassanali (2002), Wang and Spinwall (2005), Albusaidi and Olfam (2005), Hung et al (2005), Chung (2006), Akhavan and Jafari (2006)	Organizational Culture	2
Skyrme and Amidon (1997), Davenport et al (1998), Alavi and Leidner (1991), American productivity and quality center (1999), Hong et al (2005), Akhavan and Jafari (2006), Wang and Spinwall (2005), Akhavan et al (2006), Duplesis (2007)	IT	3
Skyrme and Amidon (1997), Davenport et al (1998), Alavi and Leidner (1991), Zack (1999), Wong and Spinwall (2005), Akhavan et al (2006), Duplesis (2007)	Knowledge Management Strategy	4
Brelade and Herman(2000), Yahya and Goveh(2002), Wong and Spinwall (2005)	Organization's Human resources	5
Davenport et al (1998), Holsapple and Joshi (2000), Bhatt (2000), Wong and Spinwall (2005), Akhavan and Jafari (2006)	Organizational Structure	6

A great range of factors which can affect successfully performing knowledge management are observed in the topic literature. For example, humanistic resources factor, organizational structure, organizational culture, information technology and leadership are raised as main considerations regarding performing knowledge management.

Gholipour et.al (2009) in a research entitled "measuring maturity level of knowledge management in organizations through a developed model of knowledge management maturity" investigated the verified indexes and also at developed model of

knowledge management maturity level. Data analysis was done through paired sample, Freidman tests.

The results show that strategy indexes and processes are of same rankings but the other 6 factors indexes namely (leadership, culture, organizational structure, IT, human resources, and evaluation) do not have same rankings and their priority should be considered when improving.

Also, existing factors at second and forth level of the study's developed maturity model have same rankings but the 3 factors at the third level (IT with first priority, process with second priority and organizational structure with third priority) do not have the same ranking and their priority must be attend.

Cong and Pandya (2003) found out that organizational knowledge must be kept and saved in a proper way. And in this regard, technology must be chosen in a way that people's required knowledge is at their service. Davenport and Prusak (1998) stated that IT application in knowledge management leads to improving access to knowledge and improving transmission speed for organization members (Davenport and Prusak, 1998).

MusaKhani et al (2008) in a research entitled "offering a model for measuring the readiness degree of organizations regarding knowledge management" offered a hypothetical model and measured its verification through experts and finally made use of weighted average method to determine factors level and its indexes. The main purpose of the research is determining a set of necessary requirements to successfully perform knowledge management through offering a preparation model of knowledge management. Results shows that considering final marks of effective factors in knowledge management from reporters and experts view point, these factors have categorization as follows: 1. Culture; 2. Infrastructure; 3. Structure and 4. Change management.

Rabiei and Khajavi (2010) made use of 6 factors in Tehran municipality that is, leadership, human resources, organizational structure, IT, process and organizational culture, in order to design a suitable model for knowledge management system.

Results show that leadership components, human resources, organizational structure, IT and processes have higher priorities respectively.

Monavvarian's research results show that organizational culture, IT, human resources and training affects knowledge management and the most important factors in performing knowledge management are cultural factors.

Afraz (2007) believes that determining knowledge strategy and also managing it and

organization's key choices are the first fundamental steps in applying knowledge management. Here the main purpose is providing ground for correct and necessary understanding of organization's knowledge state. Knowledge management needs this view in order to strategy regulation, projects' priority scheduling, knowledge management activities and understanding needs and special knowledge management opportunities.

"Determining and priority scheduling of main factors in successful performance of knowledge management in small and medium enterprises of Iran" is a title conducted by Valmohammadi (2009). In the current study factors, 12 leadership factors: senior management support, organizational culture, IT, knowledge management strategy, performance measurement, organizational infrastructure management, processes and activities, rewarding and motivating, removing resources' restriction, training and re-training, human resources' management, modeling the best are considered as main factors of knowledge management performance success.

According to the results, all factors ranked by reporters and experts are important in successfully performing knowledge management and only 3 factors: IT, rewarding and motivating and modeling the best have low average scores in comparison with main factors' scores. Also, leadership and senior management support and organizational culture are determined as the main factors of success by reporters and experts.

Rahnaward and Mohammadi (2009) also in a research entitled "identification of key factors in knowledge management system success in Tehran faculties and higher education institutes" considered 7 factors as main effective factors affecting knowledge management system success: Human resources development, knowledge-based orientation, cooperative culture, informational systems infrastructure, knowledge evaluation and transmission, modeling and involvement of individuals.

Findings of this research shows that effective key factors on knowledge management system success respectively are: first factor (human resources development) with a variance of 12/26, second factor (knowledge-based orientation with a variance of 11/98, third factor (cooperative culture) with a variance of 10/86, forth factor (informational systems infrastructure) with a changing dependant variance of about 10/6, fifth factor (knowledge evaluation and transmission) with a variance of 9/76, sixth factor (modeling) with a variance of 7/72, seventh factor (involvement of individuals) with a variance of 4/33.

Also, related findings of priority scheduling of factors according to Friedman test shows that: ranking of human resources development factor is more than others and it is necessary that all universities consider this factor as a key factor. Also, modeling shows the lowest ranking, but we should consider that developing competitiveness, its importance will improve. Between these two factors, are other variables respectively: cooperative culture, involvement of people, knowledge-based orientation, informational systems infrastructure, knowledge evaluation and transmission .

3. Material and Methods

The purpose of the present study is to investigate and schedule effective factors in knowledge management system in IAU of Bonab.

Sample group for the current study is staffs having BA or higher degree and faculty members of Bonab IAU. Total numbers of this people are 455.

The variables being qualitative and numerous, to determine the proper size of the described sample, and in order to make sure of findings' correctness, we make use of Cochran formula. Regarding statistics, the proper volume for the size will be 78 people chosen through random sampling.

Knowledge management cycle of Wiig (1993) is considered as the theoretical framework for knowledge management in the present study, this cycle, in fact determines how to create and use knowledge by people or organizations and has for main steps: 1.creating knowledge, 2. Knowledge sharing, 3.storing knowledge, and 4. Knowledge application. In order to investigate the above mentioned dimensions, according to various studies 6 main factors are defined in the knowledge management system as follows: 1. Knowledge management strategy, 2. Leadership, 3.culture, 4. Organizational structure, 5. Human resources, 6. IT.

We make use of questionnaire for data collection. The following table shows variables and each ones related items.

In order to test the existing hypotheses in the present study we make use of Friedman's bi-factor variance analysis test so as to investigate the effects of variables and priority scheduling them. In this test the data were as nominal and ranking frequency .Null hypotheses and lack of relationship is investigated in group matching or frequency equation of comparing groups from different levels for each. In order to investigate the existing and favorable situation of the variables in the study, paired samples tests were used.

Table 2: Variables and research model's related components

	components	Variables
Gaining knowledge, knowledge analysis, restructuring /knowledge combining, coding and modeling, knowledge organization	Knowledge creation	Knowledge Management Dimensions
Remembering knowledge, compiling knowledge in repositories, putting knowledge into repositories, archiving knowledge	Knowledge saving	
Knowledge coordination, knowledge aggregation, restructuring knowledge, combining knowledge, accessing knowledge, retrieving knowledge	Knowledge sharing	
Doing responsibility, survey and description, choice, observation, analysis and combining, evaluation, decision making and performance	Knowledge application	
Knowledge management strategy, integration of organization's strategies, knowledge management vision, knowledge management goals	Knowledge management strategy	Effective Factors in Knowledge Management
Model role, leadership style and strategic role, senior management support and commitment, participatory leadership, setting purposes and strategies, providing allocation of resources and change management	Leadership	
Organizational eliminate, reliance, humanism, culture, learning culture, adapting with change culture, knowledge-based culture, cooperation culture, innovation and creativity culture	Organizational culture	
Decentralized structure, less major formality, informal communication channels, team structure, identified roles and responsibilities	Organizational Structure	
Training staffs, staffs' cooperation, storing and maintenance and improving staffs	Human Resources	
Infrastructure, information quality, fit with staffs' needs	IT	

4. Results

Considering of reliability coefficient, Alfa coefficient for the present study's questionnaire is 0/93 with acceptable reliability degree for a questionnaire.

In the proposed conceptual model for the present study variables: knowledge management strategy; leadership; culture; organizational structure; human resources; and IT are considered as effective variables in knowledge management and four processes : knowledge creation, knowledge storing, knowledge sharing and knowledge application as the main processes in knowledge management. Considering the mean , investigated components have a low mean. This can be inferred from the low mean below 3. Also, considering skew Absolute value for four components is below 0/5, we can approximately stated that collected data are normal.

Table 3: Descriptive statistic of knowledge management

variables	Skew	Standard deviation	Mean
Knowledge creation	-0.136	0.41	2.56
Knowledge saving	0.211	0.77	2.79
Knowledge sharing	0.149	0.73	2.42
Knowledge application	-0.145	0.53	2.58

Table 4: Descriptive Statistics of Knowledge Management System Factors

variables	Skew	Standard deviation	Mean
Knowledge management strategy	0.125	0.63	2.59
leadership	0.099	0.73	2.74
Organizational culture	0.335	0.88	2.55
Organizational structure	-0.166	0.65	2.82
Human resources	0.116	0.83	2.37
IT	-0.195	0.87	2.7

As we said before, one of the research purposes is investigating existing and favorable variables' situation in this model and their difference. In order to investigate this, we make use of samples means test.

In order to priority schedule the variables in the model, we make use of Freidman's test (table 6).

Table 6: Results of Freidman Test

N	96
Chi square	43.36
df	5
Sig	0.000

Table 7: Mean and priority of ranks

variables	Mean	Priority
Knowledge Management Strategy	3.27	2
Leadership	3.71	4
Organizational culture	3.35	3
Organizational structure	4.17	6
Human resources	2.6	1
IT	3.9	5

As in the table, the estimated Chi square is 68/59 and considering its significance level lowers than 0/05; we can claim that variables in this model have no equal priority. In order to priority scheduling

variables, the mean of their rankings is used. On the basis of this test, each variable with a low mean, gain higher priority. As in table 7, the priority for variables is as follows: human resources, knowledge management strategy, organizational culture, leadership, IT strategy, organizational structure.

4. Discussion

The findings concerning effective factors in knowledge management system implementation are in alignment with national and international findings. For example, we following studies are in alignment with the present study's results.

Regarding knowledge management strategy, studies alignment with the present study are : Skyrme and Amidon (1997), Davenport et al (1998), Alavi and Leidner (1991), Zack (1999), Wong and Spinwall (2005), Akhavan et al (2006), Duplesis (2007).

Khalifeh and Vanisa (2003) see knowledge management strategy, knowledge leadership and organizational culture as being effective in knowledge management strategy success.

Regarding leadership, studies in alignment with the present study are Skyrme and Amidon (1997), Holsapple and Joshi (2000), Davenport et al (1998), Hassanali(2003),American productivity and quality center (1999), Leibiere and Sitar (2003), Wong and Spinwall (2005), Albusaidi and Olfam (2005), Chung (2006), Akhavan and Jafari (2006).

Regarding human resources, studies in alignment with the present study such as Breladeand Herman (2000), Yahya and Goveh (2002), Wong and Spinwall (2005).

Davenport and Prosk (1998) stated that using IT in knowledge management leads to improvement in accessibility to knowledge, improvement in transmission speed to organization's individuals.

Regarding IT, studies in alignment with the present study are Skyrme and Amidon (1997), Davenport et al (1998), Alavi and Leidner (1991), American productivity and quality center (1999),Hong et al (2005), Akhavan and Jafari (2006), Wang and Spinwall (2005), Akhavan et al (2006), Duplesis (2007).

References

1. Afrazeh, A., (2007), knowledge management (concepts, models, measuring, instrumentation), Amirkabir University of Technology, Second Edition, pp. 11-115.
2. Cong, X and pandya, K. (2003). Issues of knowledge management in the public sector .p:20-32 Available at: www.ejkm.com.

3. Dalkir, K. (2005), Knowledge management in theory & practice, Elsevier Butterworth-Heinemann, pp 4-20.
4. Davenport, T., De Long, D. and Beers, M. (1998), Successful Knowledge Management Projects, Sloan Management Review, Vol. 39 No. 2, pp. 43-57
5. Duffy N, (2000), Benchmarking knowledge strategy ; In Leveraging knowledge for Business performance Knowledge, Action Business School, Johannesburg;
6. Ghelich Lee, B., (2009). Knowledge management, process creation, sharing and application of intellectual capital in business, Tehran, publisher side.
7. Hasangholipour, T. and AbediJafari, H. and Khatibian, N., (2009), the evaluation of knowledge management maturity levels in organizations through the developed model of knowledge management, Journal of Management, Year IV, No. 14, p. 123
8. Holm J, (2001), Capturing the spirit of knowledge management"; paper presented at the American Conference on Information systems, BOSTON, MA, August 3-5; 2001.
9. Hung, Y. C., Huang, S. M., Lin, Q. P. and Tsai, M. L. (2005), Critical factors in adopting a knowledge management system for the pharmaceutical industry, Industrial Management & data systems, Vol. 105, No. 2, pp.164-183.
10. Monavvariyan, A., (2005), Knowledge-based Economy and management of a series of economic and administrative issues, Tehran, Institute of Education and Research Management and Planning.
11. MosaKhani, M ; AjaliGeshlajoogi, M. and SafaviMirmahaleh, S.(2008) Providing a model to assess the level of preparedness in the area of Knowledge Management (Case Study: Statistical Center of Iran), database archiving, Faculty of Management, Tehran University
12. Rahnaward, Faraj A. Mohammadi, A., (2009), identifying the key factors of knowledge management systems' success in colleges and education centers in Tehran, Information Technology Management, Volume 1, Number 3, page 37 to 52
13. Talebi, Kambiz ; TorkmaniSalimi, M., (2008), prioritization of critical success factors for implementing knowledge management in small and medium enterprises: A case study of automobile parts manufacturing companies, page 2
14. Valmohammdi, Ch (2009) Identification and prioritization the key elements of successful implementation of knowledge management in small and medium organizations, Journal of Management, No. 16.
15. Watson L, (2003), Applying Knowledge Management (e-book): Techniques for Building Corporate Memories"; Morgan Kaufmann publishers.
16. Wiig & M, Karl, (1993), People-Focused Knowledge Management: How Effective Decision Making Leads to Corporate Success. Elsevier Inc., 213-237.

9/6/2012

Semantic deviation in Free Verse

Hamidreza Farzi, Rostam Amani Astmal, Ali Dehghan

Department of Human Sciences, Tabriz branch, Islamic Azad University, Tabriz, Iran

Abstract: The semantic deviation is one of the most effective ways of personification (Prosopopeia) in the language of the poem and defamiliarization in which many poets apply it for highlighting their poetry language. In this article, it is firstly pointed to Nima as the foundation of semantic deviation and the father of free verse, then his semantic deviation has been assessed efficiently. For the reason, it is firstly written an introduction about defamiliarization and its history, personification and semantic deviation; then, it is discussed on deviation in Nima free-verse and presented a apparently that he has used different semantic deviations for his verses personification; In continue, different semantic deviations along with Nima's free-verse samples have been evaluated; this study representing that although Nima has used efficiently different elements in semantic deviation, but the most common element is defamiliarization in his poems.

[Hamidreza Farzi, Rostam Amani Astmal, Ali Dehghan. **Semantic deviation in Free Verse.** *Life Sci J* 2012;9(4):3659-3663]. (ISSN: 1097-8135). <http://www.lifesciencesite.com>. 542

Keywords: Defamiliarization, personification, semantic deviation, Nima free verse.

1. Introduction

Deviation is one of the most effective methods of language personification and defamiliarization in poem which most poets apply it to make their poems personification; In order to enter to the main discussion of the article, we point to the descriptions of defamiliarization and literary personification.

Defamiliarization and its history

This is one of the terms that is referred to Russian formalism and in fact, it is one of the essential foundations of literary schools (Nafisi, 2005). Shklovsky firstly stated this terminology and used "Ostrannenja" Russian word for this purpose? Then, Jakobson and Tyniayeva stated the term as defamiliarization. We can observe the first definitions of defamiliarization in Shklovsky's thesis by the title of "the art as a skill" (1917) (Ahmadi, 2007). Shklovsky writes in this article that: "the main aim of the art is to change forms in a reality world." His terminology in this case has been translated into "Making Strange" in terms of etimological field. In his opinion, most aesthetically issues have been considered as usual terms due to the majority application disappearing their literary impacts in this regard.

But it can be combined and applied with defamiliarization again (Shamisam, 2004).

Shklovsky believes that in the process of human perceptions, the habit is streaming continually and we percept our world unconsciously and autonomously (automatically) without being sensitive around ourselves; in other words, accustomed of the existences, things and surrounding objects force us not to see them because we got addicted to them and

this makes a kind of disruption in our feelings and sensations; therefore, the language of poem and literature should make different attitudes towards the mankind and humanity. (Karami and Nikdar asl, 2009). Shklovsky believes that in the process of human perceptions, the habit is streaming continually and we percept our world unconsciously and autonomously (automatically) without being sensitive around ourselves; without being sensitive around ourselves; in other words, accustomed of the existences, things and surrounding objects force us not to see them because we got addicted to them and this makes a kind of disruption in our feelings and sensations; therefore, the language of poem and literature should make different attitudes towards the mankind and humanity (Karami and Nikdar al., 2009).

About the domain of defamiliarization, it can be pretended that "the defamiliarization is evolved all skills and patterns which makes poem language for strange audiences discriminating the prose language and natural language and deviation in this regard. In other words, these skills are those fresh and new surroundings which blow out and awake the sleeper words and it is so-called the revolution of the words and it is so-called the revolution of the words (poem); these skills and themes have been established in both musical (rhythmical) and language terminological branches including all poem feature such as music, imagination, descriptive, pragmatic and semantic features; these make the language of the poem more recognizable than the language of prose; finally, the audience turns from semantic to language. (Hosseini Moakher, 2003). The most important issue in defamiliarization is that the familiar perception

should be eliminated and an audience cannot rely on language defamiliarity path and perceptions and he/she should try to explain ; thus, in terms of imaginalists, poem is an "organized hegemony" toward "criteria language" or "deviation from language abnormality"

1-2) **Personification:** the application of techniques that determines the utterance so that it leads to the attention of the language. This attracts the attention itself applying the literary language as a reality world. According to the Russian formalists theories, the literary works have different obviously discriminations because the language does not work in these works to make any relations but the role of personification is mostly applicable in terms of discourse. The action of personification particularly in the language of poem and through the desalinization can be appeared apparently. The poem can get far away due to its rhyme and incredibly metaphors and other applications causing to the language through prose and utterance abnormality. Kourosh Safavi in his book", from linguistics to literature", writes that, "as he believes (Lithe), the personification is possibly taking place in two moods. First, it gets deviated than the rules on the language automatically and second, there should be added some other rules on the language rules, too; thus, personification can be appeared through two semantic deviation methods and adding basic regulation. (1383: 40); therefore, to make personification, the abnormalities and recent rules of the language and or the new abnormalities should be broken (Mohabbati, 2001). If the new rules and regulations added to the language, the "adding rule" has been done and if the abnormalities and recent regulations were broken in the language, the deviation would be completed as well.

1-3) **Deviation:** This terminology is originated from modern linguistics field and lingual criticism and come into the Persian linguistics domain. Deviation in the field of linguistics points to any lingual application (from semantic to sentence structure application) which the usual events cannot be considered (Dad, 2004).

One of the most essential sides of defamiliarization in literature is the language defamiliarity and its utterance method (deviation). In sum, it can be stated that defamiliarization can be made through post- deviation that types of these post = deviations have essential role in the construction of literary works. The deviation from abnormalities may happen sophisticated and logically which assists on the enrichment of the poems language? In other words, there is a kind of transaction taking place between the language and the literature.

Thus, writers and successful poets can learn from his language to create their sonnets or poems (Rouhani, enayati, 2009). Deviation has different types including:

- 1- vocabulary, 2- pragmatic, 3- sound, 4- writing 5- semantic, 6- accent, 7- style and 8- periodical deviations. (Safavi, 2004).
- 2- Deviation in Nima's poem:

Nima Youshij (1276-1338) needs a new language to define new meanings in his mind and the tendency towards a new language needs to break the present deviations and rules in the language; he succeed to do this issue and completely changed the language of the poem. Nima in one of his letters by the name of "Neighbors' words", writes: "I again say: our literature must be change in every terms; the new topic is not enough; I mean, the change are not just related to change the rhymes or increasing/ decreasing couplets and it is not creating any so-called new – form in this regard. The main purpose is to change the approaches and give descriptive and reliable world to sophisticated people into poems....; if the same works never happen, the literary works would be effortless and our ways never appear in the field of literature" (Nima Youshij, 2006); he says that: "our literature should be changed". Mottow, appeared and made some changes in terms of semantics in the poem and new horizons came to many poets because he is a poet who sees the world better than other poets? He is a new- view poet, new-language and new- thought poet creating outstanding poems? Because he never thinks literary works done completely and all these kinds of curiosity in his thoughts made him as prodigy poet standing against any deviations and literary language and he released the traditional poems from "Tan Tan Tan" and make natural language and music for the literature.

He also broken down all cliché' and determined frames in traditional literary statement and due to the declamation and prose nature with a simple and usual language made the creation of poem. (Hoghaughi, 2005). Nima's purpose of deviation and defamiliarization is to find poetic language representing new thoughts and views in literature; Nima never accepts the traditionally cliché's and dictated rules at all; In his opinion, contractions can be made in organized mood of semantic and context; an unpredictable subject cannot be determined by a framework....

This anti- cliché' strategy of Nima is established in a position where he himself considers these dictated rules as satanic intimations and temptations. (Alipour, 2008).

Nima's greatest work must be viewed in two terms:

- the pragmatic, combination and contextual quality and attitudes
- in terms of vocabulary application, structural changes to make other words forms and give other figurative semantic forms

This kind of thinking in Nima's literary works made his as a style- based poet; An incredible style and new language that has not been ever created in the field of literature yet.

Deviation is being assessed in different aspects in Nima's poems. Nima applies both old language pragmatic and ancient language words. (Periodical deviation) and different innovations in the field of language can be observed in Nima's works. The pragmatic deviation is also used in these works. The words deviation is related to local and native language in his poems. The accent deviation is forced to the pragmatic structures of spoken language. The style deviation is applied in terms of words phonological ways that have not been common in a deviated language. The main aim of the article is to evaluate the semantic deviation of Nima's poems and his application way in the appearance of defamiliarization.

- 3- Semantic deviation: this literary process represents different semantic approaches in the sentences and combinations in the language; they are actually different than daily conversations.

Antonyms, metaphors, personifications, and similes are from semantic deviations. (Mohabbati, 2004).

The semantic field is considered as the most flexible level of a language and has been used more than other language in literary personification (Safavi, 2004).

According to Litch: defamiliarization happens mostly in the semantic domain, and in semantic deviation the comparison of the words are not positioned in semantic rules.

The meaning process has a significant role in Nima's poems and this meaning is originated from the combinations of symbols in the language system. The whole poetic context and imageries representing the poet thoughts can be perceived by these symbols. According to imaginations, the meaning and meaning - based thoughts are not a poet's challenging but in a poetic system, the meaning is an essential element in the whole poem.

(Rouhani and Enayati, 2009). The simile, metaphor, personification, paradox and synesthesia and ... are the most common elements of the semantic deviation which Nima has used them efficiently.

3-1) **Simile**: It is one of the most crucial elements of imagery which has been used mostly in the poems. Every simile has four regular bases:

Applying iterative similes destroy the languages; thus, free – verse poets try to defamiliarize their poems through making new similes. Although Nima has rarely used these similes in his poems, (Simile than Metaphor), but in these scarce cases his new invention of his poetic language is tangible in the poems.

Nima's selections and non- iterative, has made new similes which help him to focus on the personification element (humanism) in an attractive way. Nima is very interested in extra- simile style and it is so- called "clear- simile" which has been passed away from the simile process reaching to the clarification of his poems; this kind of simile application is for its intriguing mood as hidden that helped Nima's personification language. In continue, we point to some of his poetic similes as following:

The simile of the mount to brave heroes:

"The mounts as brave heroes/ as high as on together

The simile of the angles to sadness:

"where come these sounds, I do not know/ from angles, dark like the sadness

The simile of gold to the sleep:

Woven from pure gold/ sleep clean like.

As mentioned before, the highest usage of the simile in Nima's poems is as an extra- simile which we point these combinations but omit bringing his poems here:

The night desert (246), the vessels warehouse(238), the dawn wall (236), the morning star (232), the hope treasure (232), the workshop of greedy view (0228), the beautiful sound agility (225), the cash hope (219), the eyes grave (214), the empty imagery bell (214), the hen cloud (208), the night worker (138), the night blue walls (114), the sound of wounds (54), the fire torture (54), the stream of sadness eye (297), the sea stream (322), the thorn stream (52).

3-2) Personification: it represents animology or giving existence to the creatures and nature elements; In other words, all humanism features are added to the world's objects as alive beings. The personification is one of the most essential poetic handpockets or tools for creating alive imageries and each artist's vocal success depends on the personification intense usage. (Mohabbati, 1380: 175). The personification is the main and significant element in the semantic deviation of Nima's poems. (Hoghoughi, 1384: 77). In Nima's view, every object is alive in nature and has a humanity genre and character talking to Nima; for instance, the mounts

are sadness (49), the night is full of grief (52), the darkness is sick (55), the fever is anger (55), the imagination is chaos (57), the sun is ... (62), the waves are fury (74), the wave is concerned (73), the nights are worried (82), the moon laughs (83), the wave is slim (83), the night is dismal (91), a wave is overcoming on other wave passing voraciously (109), the yacht glazes (110), the sea is anger and silent (111), the waves have hugged out (113), the sun jumps and gets blue away (116), the jungle is solitude (116), the weather sings and the valley is silent (122), the is sleepen (123), the stream cries (125), the light is (130), the moon is blue (144), the light smiles (148), the night has in the heart (150), the pine is sad (150), the night is and (155), the night is dismal (169)....

The focus on Nima's personifications, it can be stated that in his polemic nature, he is very active using all main structural elements particularly the imagery and personification. Making all humanistic features to the objects and nature's elements not only makes Nima as dynamic and alive poet in the literature, but also, he gets away from the deviated language and all clichés because Nima has made his poems close to the prose language and these imageries made his poems away from the prose making Nima's poetry and personification in this regard. Although the imagery of adjectives in Nima's poems is showing the frequency of the usage in poetic features, these imageries such as "crying", "sad", "dismal", "depressed", "blue" worried and concerned, representing his turmoil interior side of the poet as well; this can be fruitful in the poet psychological terms.

3-3) Synesthesia:

It is representing the combinations of two senses together or the substitution of there both feelings literally (Shafi kadkoni, 1992).

This style is mostly applicable in the classic and contemporary literature; Bider Dehlavi, Saeb Tabrizi and Sohrab Sepehri have used these features; Nima has also used this style for his poetic personification and defamiliarization. The most incredible point of synesthesia in Nima's poems is his usage of different tastes related to taste sensation such as:

The bitter laughter: and of bitter laughter his heart takes the color (129). The sweet time: on thou, I have got Sweet lip: to his cute mind, opening sweet lips (324), the bitter imagery: with bitter imagery took sadness for awhile (351); the bitter sleep: I'm wrecked of bitter sleep glory (128).

Making sweet sin and bitter punish: the sin, the sweet others/ and of this sin- people, the bitter punish

(128); the bitter punishment: but thou nor punish, neither blame (128) and ...

Nima has considered "hearing" as like as "an eye": thou eye hears (225).

3-4) Paradox: It is so-called the verbal which including paradoxical or controversial conceptual context so that firstly it seems as meaningless and empty but its real meaning has been hidden semantically and the same paradoxical concept of the sentence makes an audience or reader's conceptual discovery (Mir Sadeghi, 2006). The paradox or controversial images can be used in different ways in literature; for example, the leafless leaf; or No clothes for wearing but nude;

Applying reverse symbols releases the nature of the language decreasing the contractive impact of the language; therefore, many poets have used this controversial language subject. (Rouhani, Enayati, 1388: 80). Paradox is one of the most essential tools and elements of poets to be considered in their personification and defamiliarization literary processes. Nima has also used paradoxical literary lines in his poems but the frequency of these usages have little observed in his poems;

For instance: "the silent song": the darkness spot of his sea sings the silent song (308).

"Talking silent man": and a man tells keep silent thou! (328). "Destroyed country": thou like touka to destroyed country (297).

"alive deadly men": alive dead people/ went into alive sleeps (206) and ...

Conclusion:

According to the mentioned discussions, personification is one of the most essential features of the poem possibly in two forms:

"deviation" and "adding rule". The obtained assessments show that Nima has used deviation to make his poetic personification in the poems and there are many different observed deviations which it has been studied here as semantic deviation; It is obvious that the semantic deviation is the most essential element of defamiliarization and personification in Nima's poems? In addition, he applied simile, synesthesia and Paradox in his poems, too; but the most important key is that the deviations of Nima is due to his tendency towards making new language in this field; he believes that: "The literature must be changed in every terms"; he succeeded to do this gigantic task in the literature and presumably Nima is the founder of these innovations in the field of poem.

References:

- 1- Ahmadi, Babak 2007. The structure and text description, Tehran, Markaz publication, 9th printing.
- 2- Hosseini Moakher, Seyed Mohsen 2003: the nature of poem from Eurpoean literary critics perspective (from Aflatoun to Dreyda), the literary researches seasonal magazine, No. 20.
- 3- Hoghaughi, Nohammad 2005, our contemporary poem 5, Tehran, neghah publication, Sixth printing.
- 4- Dad, Sima 2004: literary terminology, Tehran, Morvarid publication, 2nd printing.
- 5- Rouhani, Masoud and enayati, Mohammad (1388): the study of deviation in shafiee kadmeh's poems (M. Seresk); the literature and Persian literature jurnal (Ghoharnia), third year, No 3, frequency 11.
- 6- Shafiee kadmeh, Mohammadreza 1992: The poet of mirrors. Tehran: Aghah Publication, third Printing.
- 7- _____, 2004. Literary critic. Tehran. Aghah publication, third printing.
- 8- Safavi, Lourosh (1383). From linguistics to literature, Tehran, soureh publication, 1st printing.
- 9- Alipour, Mostafa 2008, the structure of free-verse, Tehran, fredow publication, third pronging.
- 10- Karami, Mohammad hossein and Nikdarsl, Mohammad hossein 2008. Defamiliarization form quaranic stories in khaquani Divan, language and Persian literature journal, No 50.
- 11- Mohabbati, Mahdi 2001: New innovation, Tehran: Sokhan Publication, 1st pringint.
- 12- Mirsadeghi, Meymanat 2006. The poet art dictionary, Tehran: Mahnaz publication, third printing.
- 13- Nafisi, Azar (Bita), defamiliarization in literature, cultural keyhan, Sixth year, No 20.
- 14- Youshij, Nima 1997. The collection of poems, with the supervision of sharaghim youshij, Tehran: Eshareh Publication, 1st printing.
- 15- _____ (1385). About the art and poem and poetry; by: sirus Tabbz, Tehran, Neghah publication, 1 st printing.

9/6/2012

The effect of aerobic exercise on IL6, CRP and TNF α concentration in elderly men

Ali Besharati¹, Dr. Seyed Kazem Mousavi Sadati², Mehran Ahadi³, Mir Hamid Salehian⁴

1. Faculty of Physical Education and Sport Science, Karaj Branch, Islamic Azad University, Karaj, Iran
2. Faculty of Physical Education and Sports Science, Tehran Shargh branch, Islamic Azad University, Tehran, Iran
3. Faculty of Physical Education and Sports Science, Tehran Shargh branch, Islamic Azad University, Tehran, Iran
4. Department of Physical Education, Tabriz branch, Islamic Azad University, Tabriz, Iran
A_besharati691@yahoo.com; mousavisadati@yahoo.com; Mh_salehian@yahoo.com

Abstract: The purpose of this study was to study the effect of an aerobic exercise on IL6, CRP and TNF α concentration in elderly men. For this object 30 volunteer elderly men (60-80 yrs) were voluntarily selected. They were divided into two different groups: control and experimental group. Experimental group participated in an 8-week course of aerobic exercises; 3 sessions a week for half an hour per session. Forty-eight hours before and after exercising, some blood samples were collected from the individuals to evaluate their CRP, TNF α and IL-6 factors. T-test was used to identify the differences between pre-test and post-test values. The results showed that TNF α factor changed significantly by doing the exercises, that is, the aerobic exercises affected TNF α factor. However, there was no significance difference between CRP levels before and after aerobic activities.

[Ali Besharati, Seyed Kazem Mousavi Sadati, Mehran Ahadi, Mir Hamid Salehian. **The effect of aerobic exercise on IL6, CRP and TNF α concentration in elderly men.** *Life Sci J* 2012;9(4):3664-3668]. (ISSN: 1097-8135). <http://www.lifesciencesite.com>. 543

Keywords: aerobic exercise, Interlocin-6, C Reactive protein, Tumor Necrosis Alfa, elderly men

1.Introduction

Although development and progress of sport science have progressed compared with other sciences, today human beings found sport various useful effects on different aspects of their life. So that, application of this science results were considered and adopted as an effective tool for health. In recent years, doctors considered it very important for prevention and tried to prevent illness occurrence and control and recognize health treating factors. Physical activities different aspects had various effects over inflammatory cytokins production and then body immunology system, and then it is considered that their recognition could assist us in more accurate interpretation of physiological mechanism and biological reactions (Bruunsgaard et al., 1997). Human body immunology system is an acquired and natural defense network that reacts against infectional factors and tried to decrease these factors. Immunological response decrease could lead to higher infection rate and chronic diseases such as AIDS, cancer, heart and vascular disease (Cohen et al., 1997) chronic disease occurrence among elderly people especially in people over 65 years elderly Increased (Gallistl & Sudi, 2001). That prevailed by increasing over 60 years elderly population and human lifetime increase which allocated very high percent of clinical charges to itself, therefore, finding non-medical and cheap methods considered in order

to increase health in elderly people during life time and perhaps preventing occurrence of elderly diseases (Cohen et al., 1997). On one hand, agedness often accompanied with health and sickness increase (Shephard, 1998) which resulted from genetic and environmental factors (Wang et al., 1996). Therefore, genetic and environmental factors effect on life time increase which consisted of a light nutrition regime for obese people, No smoking, lower air pollution rate and doing high level of physical activities (Selvin et al., 2007). Healthy immunological system is a genetic factor which helps life time. Therefore, both factors of physical activity decrease and immunological cells agedness helps chronic disease increase and its severity (Yeo and Park, 2002). Different researches related to physical activity and weight loss in order to immunity improvement and inflammatory factors loss regarding to exercise severity (VO_{2max}) and subjects age, had different results. Evidenced data in elderly and young people showed high level of physical activity with low rate of CRP and IL-6 (Bruunsgaard et al., 1997) in addition, fewer studies, showed effects of aerobic exercise training effects on CRP, IL-6 and other factors lower rate among middle-aged and elderly people (Shephard and Shek, 2002; Ostrowski et al., 1998). Regarding to age increase and other related problems resulted in to disability among people and finally medical services charges rise according to

sport science development and its useful effects on different aspects of life, it is necessary to use different kinds of exercises especially aerobic exercise on Immunological system function and inflammation factors in these group (elderly) of people. Also, according to studies, specially internal ones related to aerobic exercise effect of cytokines as a factor of Immunological system solution which has an effective role on inflammation process and also short-term researches and its contradicted findings, researcher tries to study an aerobic exercise period on mentioned inflammation factors in elderly and accompanied with considerable results in the field of Immunity system function Improvement by using suitable physical activity for aged people. Therefore regarding to mentioned issues, some questions presented that if 8-weeks aerobic sport activity effects on elderly immunity function? If CRP, TNF α and IL-6 systemic concentration changes elderly? Therefore, in response to above questions, researcher considers to study aerobic selected practice period effects over inflammation factors in 60-80 years elderly men.

2. Methods

Study method is semi-experimental and functional type. In this study, elderly men considered and divided into two groups, experimental group and control group and they have given pre and post-test. Exercise period of subjects were 8 weeks that before and after this period, inflammation factors (TNF α , CRP, IL-6) Evaluated and measured. Present study statistical society formulated by 30 elderly men, who prepared voluntarily. They have given medical record questionnaire and preparation for physical activity start that after completing related forms and performing medical examination and medical health certificate issuance, 30 people selected which placed in two experimental and control (15 subjects) groups, randomly. Measurement tools consisted of health record form. In order to collect required information relating to elderly mental status, ensuring about their health and satisfaction of subjects participation in the study and a questionnaire with these contents has been used; cotton, alcohol, 5cc one-time using sterile syringe, syringe head for collecting blood, sterile test tube in order to collect and send blood to lab, Isolated laboratory kit, used for measuring CRP, TNF α and IL-6. In this study, in order to collect information library and field method have been used. In the library method, by using text-reading, voucher-taking, statistic -reading, tables, literature study, issue records and study matter, collected information and in the field method data collected by referring to the subjects and direct relation with them. In this

study, Among two experimental groups and elderly men evidence, experimental group in an exercise program in addition to normal practices, participated for 8 weeks, this exercise program consisted of walking activity three times a week and any session considered 30 minutes with 60-65 storage heart rate severity any exercise program session consisted of 3 exercise stages: 1 warming up 2 Main exercise 3 cooling stage. In warming up stage, subjects, initially, walked for 3 minutes very slowly and softly with 30-35% storage heart rate severity and then performed 5 minutes tensional 5 minutes tensional movements which extended totally 8 minutes. Aerobic exercise program performed about 20 minutes in the first week. Exercise period and severity in exercise program initiated from light style and increased gradually according to extra load rule, then rose to 30 minutes in the next weeks. After exercise ending, cooling stage begins that consisted of 3minutes soft walking and 5 minutes tensional movements which have been taken 8 minutes. 48 hours before and after exercise, blood collected and exercise affects studies over these factors. T-test was used to get the difference between pre and post test results at $p < 0.05$.

3. Results

Table 1. Statistical data related to aerobic exercise effects on elderly men IL6 factor

	N	Mean + St dev	T	Df	T	Sig
Pre Exercise	15	0.47±0.77	-3.72	14	0.02	Sig
post Exercise	15	23.22±23.69				

As it is shown in table 1, test statistics obtained from elderly men equals $t = -3.72$. Elderly men IL-6 factor before and after aerobic exercise has significant difference with each other ($P = 0.02$).

Table 2. Statistical Data related to aerobic exercise effects on elderly men TNF α factor

	N	Mean + St dev	T	Df	T	Sig
Pre Exercise	15	0.14±0.44	-2.62	14	0.02	sig
post Exercise	15	74.27±109.4				

As it is shown in table 2, elderly men test statistics equal $t = -2.62$. TNF α factor in elderly men was different before and after exercise ($P = 0.02$).

Table 3. Statistical Data Related to aerobic exercise effects on elderly men CRP factor

	N	Mean + St dev	T	Df	T	Sig
Pre Exercise	15	3.33±1.04	0.61	14	0.55	No sig
post Exercise	15	3.13±0.83				

As it is shown in table 3, elderly men test statistics equal $t=0.61$. There is no significant between CRP factor before and after exercise and had no difference with each other ($P=0.55$).

4. Discussion and Conclusion

4.1. IL-6 changes after exercise (Sport)

Based on present study findings and t-test results which have been conducted among group average after test, there was significant difference between elderly men IL-6 factor rate. Some studies confirmed recent research results (Miles & Stephen, 2004; Ostrowski et al., 1998, 2000; Shephard, 1998) including Philips et al (2008) following long term sport on untrained elderly men and women (89-70) and found significant changes in order to decrease of IL-6 concentration (Sharif et al., 2000). Yeo and Park (2004) by performing nutritional diet with sport in obese men after menopause decreased IL-6 level. Also, Gallistl and Sudi (2001) studied obese teenager and children with the effects of nutritional diet and sport which found significant changes in decreasing their IL-6 concentration. Ostroskey et al (2000) reported a significant decrease in IL-6 level two hours after Marathon contest. On the other hand, some studies found different results with present study findings: Philips and Childs (2003) conducted on healthy non-practiced men reported IL-6 level immediately after activity. Cytokines excretion mechanism such as IL-6 during sport was very complex. Lymphocytes mentioned as effective factors in increasing cytokines. Brunnsgard et al (1997) found a positive correlation between IL-6 increase (2 hours after activity) and blood lymphocytes concentration (20 minutes after activity). In addition, lymphocytes could involve in IL-6 increase, third factor (Hormone factor) could increase both factors (IL-6 and lymphocytes) Also, increasing resource could be existing Macrophages, Endothelial cells and fibroblasts in muscles and or leukocytes penetration from blood. The result was not parallel with Rahimi et al. (2012). One long-term sport period decreased IL-6 production in both rest time and in response to severe exercise. Therefore, IL-6 changes during sport affected by subject's type, while results of trained subjects and athletes necessarily could not be used for trained people.

People who haven't exercised probably experience more muscular damages and cytokines response to running slopes were more (Selvin et al., 2007). About Normal people IL-1, IL-10 and IL-6 cytokines production rise during sport control pre-Inflammatory cytokines such as TNF α (these cytokines production related with low-degree chronic Inflammation and disease such as cardio-vascular diseases and diabetes type II). Finally, cytokines production is important for the health concept. It must be recalled that severity, type and period of exercise, preliminary preparation level of subjects, gender, age, place, and time of sampling nutritional diet, Heredity, characteristics and measuring tools sensitivity are determining factors in cytokines production (Miles & Stephen, 2004; Nicklas, 2008; Petersen & Ostrowski, 2005; Selvin et al., 2007; Yanh kuroiwa et al., 2001) that could be a reason for sturdy results difference such as present study with other ones.

4.2. TNF α changes after sport:

Based on results of this study, there was a significance difference in TNF α factor among elderly men ($t=-2.62$ and $p=0.02$). Also based on correlative t-test results, average difference of control group scores to experimental group who performed aerobic exercise ($p=0.10$, $\alpha<0.05$) was significant and this means 8-weeks aerobic exercise caused TNF α level changes. Kasiolima et al (2008) showed that elderly people's TNF α level with diabetes type 2 after exercise increased significantly. Also Pederson and Brunsgard (2003) in reviewing beneficial role of sport in decreasing low-grade inflammation of elderly people, stated that age rise related to low-grade inflammation and preliminary mediators of this inflammatory activity is IL6 and TNF α . In epidemiological study of both cytokines with obesity, related to insulin and atroscleorose strength. Also, stated that TNF α is a stimulator for Resistencia to Insulin (Hosseini & Rabbani, 2005; Petersen & Ostrowski, 2005)]. Yeo and Park (2002) by applying nutritional diet with sport and exercise in obese men after menopause found that cytokines level specially TNF α had significant decrease. Also in Vahdat research with the title of aerobic exercise period effects on liptin TNF α and IL6 level in thin and fat men found significant changes in variable concentration decrease specially TNF α in thin men (Cosio-lima, 2008). As implied about serum TNF α , severity, type and period of exercise subjects preliminary preparation level, age, place and time of sampling, heredity, drugs, features, measuring tools sensitivity are the factors for determining production (Nicklas, 2008; Petersen & Ostrowski, 2005; Sharif et al., 2000; Selvin et al., 2007; Wang et al., 1996)

that could be a reason for study results such as present study with other ones.

4.3. CRP changes after exercise:

In the present study, performing aerobic exercise for 30 minutes in elderly men couldn't make significant difference in CRP level according to the time before exercise. Indeed, regarding to correlative t-test results and CRP scores average difference in experimental and control group ($p=0.62$, $t=0.49$), sport had no effects on CRP factor level. In Nicholas et al (2008) studies which investigated long-term exercise effects on IL-6 and CRP factor in 70-89 years elderly men and Men; there was no significant difference in CRP level (Pedersen & Bruunsga, 2003). Also, Mile et al (2004) compared CK, CRP and IL-6 response of men and men in 20-miles race at altitude showed that remarkable difference has not been seen in CRP level of two groups (Ostrowski et al., 2000; Shephard and Shek, 2002) that is similar to present study findings. On the other hand, some studies found different results with present study findings Including Selvin et al (2008) findings. This researcher and his studies which investigated effects of weight loss on CRP, reported significant decrease in CRP level. Okita et al (2009) studies which investigated sport with weight loss in apparently healthy men showed that sport caused lower CRP level. It seems that difference in sport activity severity and its duration, also weight loss and nutritional diet, heredity, using dietary supplements are the effective factors on inflammatory factors level, especially CRP, Which are the possible reasons for the difference of present study findings with above studies. Based on present study findings, an aerobic exercise period caused no sensible changes in elderly men IL6 factor level but changed their TNF α factor level, also had no effects on CRP factor level. Indeed, sport increased TNF α factor level after 8-weeks exercise and this was statistically significant. Totally, Results showed that performing long-term aerobic exercise with middle severity might create a potential for immunity responses increase by means of increasing t-cells production in elderly people. Therefore, performing long-term aerobic activities with average severity controls cytokines synthesis which are necessary for immunity responses regulation and improve immunity function which decreased due to agedness and resulted into elderly lifetime period Increase.

References

1. Bruunsgaard, H., Galbo, H., Halkjaer- Kristensen, J., Johansen, T.L., MacLean, D.A., Pedersen, B.K. (1997). Exercise-induced increase in serum

interleukin-6 in humans is related to muscle damage. *The Journal of physiology*, 499 (3):833.

2. Cohen, H.J., Pieper, C.F., Harris, T., Rao, K.M.K., Currie, M.S. (1997). The association of plasma IL-6 levels with functional disability in community-dwelling elderly. *The Journals of Gerontology Series A: Biological Sciences and Medical Sciences*, 52 (4):M201.
3. Cosio-lima, L. (2008). Preliminary study of the effects of age and type 2 diabetes on the release of IL-6, IL-10, TNF and Cortisol in response to acute exercise. *Journal of American Cell Cardiology*, 119 (3).
4. Febbraio, M.A., Pederson, B.K. (2002). Muscle – derived interleukin 6: mechanisms for activation and possible biological roles. *The FASEB Journal*, 16: 1335 – 1347.
5. Gallistl, S., Sudi, K.M. (2001). Changes in serum interleukin-6 concentrations in obese children and adolescents during a weight reduction program. *International Journal of Obesity*, 25:1640-1643.
6. Hosseini, P.K, Rabbani, M. (2005). Tehran: Industrial and scientific studies Organization.
7. Kasapis C, Thompson, P.D. (2005). The effects of physical activity on serum reactive protein and inflammatory markers: asystemic review. *Journal of American Cell Cardiology*, 45: 1563 – 1569.
8. Miles, M.P., Stephen, B. (2004). IL-6, CRP and CK responses to a 20-Mile race at altitude in women verses men, *Medicine Science in Sports Exercise*, 36(5) : PS150.
9. Nicklas, B, 92008). Exercise Training and Plasma CRP and IL-6 in the Elderly. *JAM*. 56:2045-2052.
10. Okita, K. (2009). Can Exercise Training With Weight Loss Lower Serum C-Reactive Protein Levels? *Arterioscler Thromb Vasc Biology*, 8.
11. Ostrowski, K., Rohde, T., Zacho, M. (1998). Long – term muscle activity. *Journal of Physiology*, 508: 949 – 953
12. Ostrowski, K., Schjerling, P., Pedersen, B.K. (2000). Physical activity and plasma interleukin-6 in humans – effect of intensity of exercise. *European Journal of Applied Physiology*. 83:512-515.
13. Pedersen, B.K., Bruunsga, H. (2003). Possible beneficial role of exercise in modulding low-grade inflammation in the elderly. *Scandinavian Journal of Medicine and Science Sports*, 13: 56 – 62.
14. Pedersen, E.W., Ostrowski, K. (2000). Effect of vitamin supplementation on cytokine response and on muscle damage after strenuous exercise.

- American Journal of Physiology*, 280: C1570 – C1575.
15. Phillips, T., Childs, A.C. (2003). A dietary supplement attenuates IL-6 and CRP after eccentric exercise in untrained males. *Medicine Science and Sports Exercise*, 35 (N12).
 16. Peake, J.M., Suzuki, K. (2005). Plasma cytokine changes in relation to exercise intensity and muscle damage. *European Journal of Applied Physiology*.
 17. Petersen, E.W., Ostrowski, K. (2005). Effect of vitamin supplementation on cytokine response and on muscle damage after strenuous exercise. *American Journal of Physiology Cell Physiology*. 280: C1570 – C1575.
 18. Rahimi, A., Hojjat, S., Besharati, A., Shokrgozar, A.R. (2012). The effect of an aerobic exercise on IL6, CRP and TNF α concentration in women, *Annals of Biological Research*, 3 (1):125-131.
 19. Sharif, M., Shepston, L., Elson, C.J. (2000). Increased serum reactive protein may reflect events that precede radiographic progression in osteoarthritis of the knee. *Annals of Rheum Dis*. 59: 71 – 74. [pubmed: 10627432].
 20. Selvin, E., Paynter, P., Erlinger, M.D. (2007). The Effect of Weight Loss on C-Reactive Protein. *Arch International Medicine*, 167:31-39.
 21. Shephard, R.J. (1998). Cytokine responses to physical activity, with particular reference to IL-6: source, action, and clinical implications. *Crit Rev Immunol*, 22(3):165 – 182.
 22. Shephard, R. and Shek, P. (2002). Exercise, aging and immune function. *International Journal of Sports Medicine*. 6(1): PP 1- 6.
 23. Wang, B., Beiqing, L., Chen, M. (1996). Age-related decreases in IL-2 production by Human cells are associated with impaired activation of nuclear transcriptional factors AP-1 and NF-AT-1. *Cellular Immunology*, 162(2): 185-195.
 24. Yanh kuroiwa, A., Tanaka, H., Shindo, M., Kiyonaga, A., Nagayama, A. (2001). Effect of modern exercise on immune senescence in men. *European Journal of Applied Physiology*, 86(2): 105 – 111.
 25. Yeo, E., Park, S. (2002). Age-dependent agonist-specific dysregulation of membrane-mediated signal transduction: emergence of the gate theory of ageing. *Mechanisms of Aging and Development*, 123:PP1563-1578.

9/6/2012

External or Internal Attention for Vertical Mass Displacement

Mir Hamid Salehian¹, Recep GURSOY², Elhan ŞEN², Mohsen Shir Mohammad Zadeh

1. Department of Physical Education, Tabriz branch, Islamic Azad University, Tabriz, Iran
2. Associate Professor, Department of Physical Education and Sport Sciences, Ataturk university, Erzurum, Turkey
3. Department of Physical Education and Sport Sciences, Azarbayjan Shahid Madani University, Iran

Abstract : The purpose of this study was to determine the effect of two different kind of attentional focus (internal and external) on trunk vertical displacement in university male basketball beginners. Thirty male students were chosen voluntarily with no knowledge of basketball and matched in 2 groups: Internal (focus on the ball) and External (focus on the basket). Following the ten practice sessions and after a day of rest a retention test was conducted for each group. Data were analyzed by independent T test. By analyzing the proposed hypotheses at the $P \leq 0.05$ showed the superiority of external focus than internal one on trunk vertical displacement.

[Mir Hamid Salehian, Recep GURSOY, Elhan ŞEN, Mohsen Shir Mohammad Zadeh. **External or Internal Attention for Vertical Mass Displacement.** *Life Sci J* 2012;9(4):3669-3672]. (ISSN: 1097-8135). <http://www.lifesciencesite.com>. 544

Key words: external attention, internal attention, displacement

1. Introduction

There has been some evidence that an individual's focus of attention has a significant influence on motor performance and learning. It has been shown that directing a performer's attention to the movement effect (external focus), is more beneficial than attention directed to the movement itself (internal focus) (Wulf at al., 1998, 2001, Wulf, 2007 a, b). Most research has used skills that require the manipulation of an object to achieve the action goal, such as hitting a golf ball (Wulf at al., 1999; Perkins-Ceccato at al., 2003; Wulf & Su, 2007), shooting a basketball (Al-Abood at al., 2002; Zachry at al., 2005), kicking a football (Zachry, 2005) or soccer and volleyball (Wulf at al 2002, 2003), hitting a tennis ball (Wulf at al., 2000), baseball (Castaneda, & Gray, 2007), and even dart throwing (Marchant, 2007). The advantages of an external focus are not only seen when compared with internal focus conditions, but also when compared with control conditions (Landers at al., 2005; McNevin, 2002, 2003). This pattern of results suggests that an external focus has the capacity to enhance performance and learning. The rationale for focusing on the movement effects rather than on the movement itself is explained by the "constrained action hypothesis" (McNevin at al., 2003; Wulf at al., 2001). This hypothesis suggests that directing one's attention to the actual movements (internal focus) might "constrain" the motor system and interfere with the automatic control processes, while focusing on the effects of the movement (external focus) actually frees up the performer and enhances the automatic control processes. Overcoming this analysis paralysis, participants focus on the effects of

their actions so the movement pattern becomes more "automatic", demonstrating a smooth, coordinated response; For example, balancing on a stabilometer (Wulf et al., 2001), postural adjustments in balance tasks (Wulf at al., 1999, 2001, Wulf, 2007), hitting a target (Wulf at al., 1999, 2002) or balancing (Wulf at al. 1998, Landers at al., 1999 Shea & Wulf, 1999; Totsika & Wulf, 2003), but also for tasks that require the production of maximal forces and displacement of the center of mass (Vanezis & Lees, 2005; wulf at al., 2007; Salehian, 2011). Zachry et al. (2005) believed that an external focus of attention not only enhances movement efficiency, but also reduces "noise" in the motor system that delays fine movement control and disturbs the outcome of the movement. This indicates that participants produced greater forces under that condition.

Although evidence is convincing regarding the effectiveness of an external focus in practicing motor skills, there is still much to be discovered. Conflicting findings demonstrate that age (Emanuel at al., 2008) , gender (Wulf at al., 2003) , skill level (Perkins at al., 2003; Ford at al., 2005; Castaned & Gray, 2007; Wulf, 2008), complexity of the skill (Poolton at al., 2006; Denny, 2010), and individual preferences (Wulf at al., 2001), sport settings (Porter at al., 2010) might all play a role regarding the efficacy of internal and external attention focus in skill performance. Recently, Weiss et al. (2008) discovered that one's preferred focus of attention could play a role in the effectiveness of attention focus, suggesting that an internal focus did not necessarily lead to a decrease in performance if it was the participant's preferred strategy. On the other hand, some studies done on the effect of kinematics

parameters on the optimal shooting have paid only to factors influencing on successful shooting in basketball, but some of these factors are common in unsuccessful shooting, too (Kudson, 1993). Some techniques such as release angle, speed, velocity and height, launch of the force to be applied to the ball, speed and angle of shoulders and trunk play greater roles on a successful throw (Raul, 2002). Vanezis and Wulf believed displacement of the trunk on doing a task such as jump and reach is an important factor to reach the aim (Vanezis & Lees, 2005; Wulf, 2009), and it is believed mass displacement plays a great role in successful basketball free throw (Raul, 2002), but to prove this matter there is a need to do more researches.

So, according to the contrary results we decided to examine whether an external focus would have a great impact on trunk vertical mass displacement in university male basketball beginners, compared to internal focus. If this were the case, it would complement and extend the findings of previous studies, which have almost exclusively shown benefits of external focus for tasks requiring movement accuracy. In two experiments, participants performed a shooting task under two conditions. Under external focus conditions participants were instructed to focus on the basket, whereas under internal focus conditions they were asked to focus on the wrist.

2. Methods

Thirty male students (age 18- 30 years) from Tabriz Islamic Azad University, with no knowledge of basketball shooting and not aware of the specific purpose of the study were assigned randomly to one of two experimental groups (n=15) based on their pre-test scores of 10 shooting. The two matched groups were assigned one of two practice conditions. On the ten consecutive sessions of practice, all participants received the same initial instructions regarding the basket (external) and wrist (internal), but no feedback during the post-test. After a day of rest, participants performed a retention test consisting of 10 trials with 10 seconds rest between each trial. The task involved was the throwing ball toward basket from penalty line in basketball, putting markers on the subjects' trunk vertical mass displacement and recording the motions from sagittal and frontal surfaces by two Panasonic cameras with 100 fps speed. A motion analysis software was used to analyze information.

Descriptive statistics were calculated to report the mean performance of the two practice groups for the retention test scores (Table). Data were analyzed using the Statistical Package for the Social Sciences (SPSS) version 16. An independent samples t-test

was used to determine significance between the experimental conditions.

Table 1. Center of Mass Displacement under Internal and External Focus Conditions

Segments	Groups	Mean	Std. dev	T	Df	Sig.
Trunk	Internal	2.18	0.409	-	28	0.000*
	External	3.22	0.765			

As it shown in Table 1, the mean displacement of trunk vertical for internal group was 2.18 and for external group was 3.22 with $F(9.58) = p < .05$.

3. Results

Participants' trunk vertical mass displacement reached a higher changes when they were instructed to adopt an opposed to an internal focus, (3.22) for external focus group, and internal focus (2.18), (see table). independent t-test showed a statistical significance between the two practice conditions in trunk vertical mass displacement ($p = .000$).

4. Discussion and Conclusions

The purpose of this investigation was to determine if trunk vertical mass displacement in an external focus would be better than an internal focus when performing a basketball set shot. Among numerous studies on attention focus, few have considered the effects of attention focus on trunk vertical mass displacement. Traditionally, coaches and teachers have been trained in teaching sport skills using an internal focus of attention. The result of this study supported that an external focus was more effective than an internal focus in trunk vertical mass displacement when performing shooting in basketball and as Raul (2000) believed mass displacement of body had an important impact on successful shooting. This finding appears to be parallel to several studies exploring the benefits of an external focus when compared to an internal focus, including, the basketball free throw (Al-Abood et al., 2002), the standing soccer shot and volleyball serve (Wulf et al., 2002), the golf pitch shot (Wulf et al., 1999), putting (Poolton et al., 2006) and center of mass displacement (Wulf et al., 2007; Salehian, 2011). Throwing ball to the basket used in this study involving several variables, including the attentional focus of the performer. These factors may explain the difference in the results of this study compared to other studies done on this topic. The only way to raise the mass displacement is by increasing the magnitude of external force exerted. From a performance perspective, one can deduce that participants either increased force production, or optimized coordination between and among the

segments during a task to produce a more continuous summation of segmental velocities (Wulf et al., 2007).

The results of the present study provide converging evidence that a change in the focus of attention can affect greater COM displacement (Vanezis & Lees, 2005; Wulf, 2007, Salehian, 2011): Focusing on a target (external focus) resulted in greater trunk vertical mass displacement in than focusing on the wrist with which the ball was to be thrown (internal focus) and at last a successful throw was achieved. Moreover, attentional focus instructions have been found to affect EMG activity not only in "related" muscle groups, but also in "unrelated" muscle ones (Zachry, et al.2005, Vance, et al., 2004). The present results are in line with those findings in demonstrating that the attentional focus on one part of the body can impact whole-body displacement. Wulf 's experiments (Wulf et al., 2007) showed greater vertical displacement of the center of mass. This indicates that participants produced greater forces under that condition. While it might be surprising that a simple change in an individual's focus of attention can enhance force production, and previous studies have shown that an external focus results in more efficient movement patterns (Zachry, et al., 2005, Vance, et al., 2004, Marchant, et al., 2006). In those studies, the same outcome (i.e., weight lifted in a given amount of time) was achieved with less muscular activity when an external focus, as opposed to an internal or no particular focus (Vance, et al., 2004, Marchant, et al., 2006). Interestingly, muscular activity was reduced not only for agonist muscle groups, but also for antagonist muscles (Marchant, et al., 2006). This suggests that a focus on the movement effect might not only facilitate an effective recruitment of intra-muscular, but also inter-muscular coordination (Hollmann & Hettinger, 2000). Marchant et al.'s (2009 b) study also showed beneficial effects of an external focus on maximum force production. Using an isokinetic dynamometer, they had participants produce maximum voluntary contractions of the elbow flexors under internal-focus (focus on arm and muscles) or external-focus (focus on the crank hand-bar) conditions. The results showed that participants produced significantly greater peak joint torque when they focused externally compared with internally.

References:

1. Al-Abood, S.A., Bennett, S.J., Hernandez, F.M., Ashford, D., Davids, K. (2002). Effects of verbal instructions and image size on visual search strategies in basketball free throw shooting. *Journal of Sports Sciences*, 20, 271–278.
2. Castaneda, B., Gray, R. (2007). Effects of focus of attention on baseball batting performance in players of differing skill levels. *Journal of Sport & Exercise Psychology*, 29(1), 60-77.
3. Denny, G.V., (2010). Where to focus Attention when performing the Float Serve in volleyball, *Journal of coaching Education*, 3, 1-13.
4. Emanuel, M., Jarus, T., Bart, O. (2008). Effect of focus of attention and age on motor acquisition, retention, and transfer: A randomized trial. *Physical Therapy*, 88(2), 251-260.
5. Kudson, D. (1993). Biomechanics of the basketball jump shoot- six key teaching points. *Journal of Physical Education Recreation and Dance*. 64(2):67-73.
6. Landers, M., Wulf, G., Wallmann, H., Guadagnoli, M.A. (2005). An external focus of attention attenuates balance impairment in parkinson's disease. *Physiotherapy*, 91, 152–185.
7. Marchant, D., Clough, P., Crawshaw, M. (2007). The effects of attentional focusing strategies on novice dart throwing performance and their task experiences. *International Journal of Sport and Exercise Psychology*, 5, 291-303.
8. Marchant, D., Greig, M., Scott, C., Clough, P. (2006). Attentional focusing strategies influence muscle activity during isokinetic bicep curls. In Poster presented at the annual conference of the British Psychological Society. Cardiff, UK.
9. Marchant, D., Greig, M., Scott, C. (2009a). Attentional focusing instructions influence force production and muscular activity during isokinetic elbow flexions. *Journal of Strength and Conditioning Research*, 23, 2358–2366.
10. Marchant, D. C., Greig, M., & Scott, C. (2009b). Attentional focusing strategies influence bicep EMG during isokinetic biceps curls.
11. Maxwell, J. P., Masters, R. S.W., Eves, F. F. (2000). From novice to no know-how: A longitudinal study of implicit motor learning. *Journal of Sports Science*, 18, 111–120.
12. McNevin, N.H., Shea, C.H. Wulf, G. (2003). Increasing the distance of an external focus of attention enhances learning. *Psychological Research*, 67, 22-29.
13. McNevin, N.H., Wulf, G. (2002). Attentional focus on supra-postural tasks affects postural control, *Human Movement Science*, 21, 187-202.
14. Perkins-Ceccato, N., Passmore, S., & Lee, T. (2003). Effects of focus of attention depend on golfers' skill. *Journal of Sports Sciences*, 21(8), 593-600.
15. Poolton, J., Maxwell, J., Masters, R., & Raab, M. (2006). Benefits of an external focus of attention: Common coding or conscious processing? *Journal of Sports Sciences*, 24(1), 89-99.

16. Porter, J., M., Ostrowski, E., J., Nolan, R., P. & Wu, W., F.W. (2010). Standing long-jump performance is enhanced when using an external focus of attention, *Journal of Strength and Conditioning Research*, 24(7), 1746-1750.
17. Raoul, R. D., Oudijanse, R., Van de Langenberg, R.I. (2002). Aiming at a far target under different viewing condition: visual in basketball jump shooting. *Journal Human Movement Sciences*. 21: 457-80.
18. Salehian, M., H., Yasrebi, B., Zehsaz, F., Afkhami I, Imani, P. & Fazlollahi, S. (2011). Influence of attentional-focus on center of mass displacement of body different segments in basketball set shot, *Annals of biological research*, 2 (3), 394-400.
19. Totsika, V., Wulf, G. (2003). The influence of external and internal foci of attention on transfer to novel situations and skills. *Research Quarterly for Exercise and Sport*, 74, 220–225.
20. Vance, J., Wulf, G., Töllner, T., McNevin, N. H., & Mercer, J.(2004). EMG activity as a function of the performer's focus of attention. *Journal of Motor Behavior*, 36, 450–459.
21. Vanezis, A., & Lees, A. (2005). A biomechanical analysis of good and poor performers of the vertical jump. *Ergonomics*, 48, 1594–1603.
22. Weiss, S., Reber, A., & Owen, D. (2008). The locus of focus: The effect of switching from a preferred to a non-preferred focus of attention. *Journal of Sports Sciences*, 26(10), 1049-1057.
23. Wulf, G. (2007a). Attentional focus and motor learning: A review of 10 years of research (target article). *E-Journal Bewegung und Training*, 1, 1–11. Retrieved July 11, 2009, from http://www.ejournal-but.de/doks/wulf_2007.pdf.
24. Wulf, G. (2007b). *Attention and motor skill learning*. Champaign, IL: Human Kinetics.
25. Wulf, G. (2008). Attentional focus effects in balance acrobats. *Research Quarterly for Exercise and Sport*, 79, 319–325.
26. Wulf, G., Höß, M., & Prinz, W. (1998). Instructions for motor learning: Differential effects of internal versus external focus of attention. *Journal of Motor Behavior*, 30, 169–179.
27. Wulf, G., Landers, M., Lewthwaite, R., & Töllner, T. (2009). External focus instructions reduce postural instability in individuals with Parkinson disease. *Physical Therapy*, 89, 162–168.
28. Wulf, G., Lauterbach, B., & Toole, T. (1999). Learning advantages of an external focus of attention in golf. *Research Quarterly for Exercise and Sport*, 70, 120–126.
29. Wulf, G., McConnel, N., Gärtner, M., & Schwarz, A. (2002). Feedback and attentional focus: Enhancing the learning of sport skills through external-focus feedback. *Journal of Motor Behavior*, 34, 171–182.
30. Wulf, G., & McNevin, N. H. (2003). Simply distracting learners is not enough: More evidence for the learning benefits of an external focus of attention. *European Journal of Sport Science*, 3, 1–13.
31. Wulf, G., McNevin, N.H., Fuchs, T., Ritter, F. and Toole, T. (2000). Attentional focus in complex motor skill learning, *Research Quarterly for Exercise and Sport*, 71, 229-239.
32. Wulf, G., McNevin, N. H., & Shea, C. H. (2001). The automaticity of complex motor skill learning as a function of attentional focus. *Quarterly Journal of Experimental Psychology*, 54A, 1143–1154.
33. Wulf, G., Mercer, J., McNevin, N.H. and Guadagnoli, M.A., (2004). Reciprocal influences of attentional focus on postural and Supra-Postural Task Performance, *Journal of Motor Behavior*, 36, 189-199.
34. Wulf, G. and Prinz, W. (2001) Directing Attention to movement effects enhances learning: A Review, *Psychonomic Bulletin and Review*, 8, 648-660.
35. Wulf, G., & Su, J. (2007). An external focus of attention enhances golf shot accuracy in beginners and experts. *Research Quarterly for Exercise and Sport*, 78, 384–389.
36. Wulf, G., Töllner, T. and Shea, C.H. (2007). Attentional focus effects as a function of task complexity, *Research Quarterly for Exercise and Sport*, 78, 257-264.
37. Wulf, G., Wächter, S. and Wortmann, S. (2003). Attentional focus in motor skill learning: Do females benefit from an external focus? *Women in Sport and Physical Activity Journal*, 12, 37-52.
38. Wulf, G., Weigelt, M., Poulter, D. R., & McNevin, N. H. (2003). Attentional focus on supra-postural tasks affects balance learning. *Quarterly Journal of Experimental Psychology*, 56, 1191–1211.
39. Wulf, G., Zachry, T., Granados, C., & Dufek, J. S. (2007). Increases in jump-and-reach height through an external focus of attention. *International Journal of Sports Science and Coaching*, 2, 275–284.
40. Zachry, T. (2005) Effects of attentional focus on kinematics and muscle activation patterns as a function of expertise, Unpublished Master's Thesis, University of Nevada, Las Vegas.
41. Zachry, T., Wulf, G., Mercer, J., & Bezodis, N. (2005). Increased movement accuracy and reduced EMG activity as the result of adopting an external focus of attention. *Brain Research Bulletin*, 67, 304–309.

9/6/2012

Prevalence of House Dust Mites in Two Levels of Dorms (Hotel and Motel) of Jeddah District Western Saudi Arabia

Nada Othman Edrees

Department of Biology, Faculty of Science for Girls, King Abdulaziz University, Jeddah, Kingdom of Saudi Arabia.
nada.algalb@hotmail.com; nedrees@kau.edu.sa; dr_nada_edrees2006@yahoo.com

Abstract: This study was designed to test the null hypothesis that the different level of the dorms has a real effect on the quantitative and qualitative existence of the house dust mites (HDM). Also to determine the most important factors that control the distribution and colonization of HDM. The study was conducted at Jeddah city western Saudi Arabia. 12 dorms were tested; 6 hotels and 6 motels. The samples were collected twice a month along three months (Dec, Jan., Feb. 2009). Mites were separated using modified Berleses tunnel. Ten species of HDM were extracted from studied dwellings. The mite assemblage in motels was dominated by *Dermatophagoides pteronyssinus* (23.7%). In hotels to the mite collection was co-dominated by *D. pteronyssinus* (27.6 %) and *D. farinae* (21.8 %). The mean total individuals in motels was 5012 individuals per 50 grams of dust in correspond to 2149 individuals per 50 grams of dust in the hotels. Up to 66.6% of the motels had a population of more than 100 individuals per 1 gram of dust, however none of the studied hotels embraced more than 50 individuals per 1 gram of dust. In conclusion the level of the dorms had a clear effect on the quantitative existence of HDM, but a qualitative effect can not be identified. Also, it was speculated that the most frequent cleaning as well as density and economic status of residents were the main factors matched with a direct impact on the mite contamination rate of the dorms.

[Nada Othman Edrees. **Prevalence of House Dust Mites in Two Levels of Dorms (Hotel and Motel) of Jeddah District Western Saudi Arabia.** *Life Sci J* 2012;9(4):3673-3683]. (ISSN: 1097-8135).
<http://www.lifesciencesite.com>. 545

Keywords: null hypothesis; house dust mites (HDM); *Dermatophagoides pteronyssinus*; dorm; mite assemblage; population

1. Introduction

House dust mites are ubiquitous in public buildings and homes worldwide. They are medically important creatures, where many species are the source of allergens that sensitize and induce allergic reactions in genetically predisposed persons (Arlian, 2000 & 2002). The most prevalent allergy-causing mites in homes differ geographically between homes within a geographical region and among areas within a home (Arlian et al., 2002; Edrees 2009).

Indoor relative humidity, temperature and enough food are generally considered to be the most important factors determining community composition and population dynamics of the major groups of dust arthropods. The optimum condition for development being between 18 – 27 °C (Soltani et al., 2011) with a relative humidity of 70% - 75% (Valero and Serrano, 2004). Their major food source is skin scales, textile fibres, food crumbs, hair and wood pests fungi, plant pollen and organic debris (Vande Lustgraat, 1978; Edrees, 2009 and Soltani et al., 2011).

Under optimal breeding conditions about 5000 of house dust mite individuals may be present in just 1g of mattress dust but up to 15600 has been recorded (Soltani et al., 2011). It has also been shown that rugs constitute a suitable habitat for house dust mites (De Boer, 1990; De Boer and Kuller, 1995). De

Boer et al. (1999) mentioned that a rug from the living room floor of a Dutch home was found to contain more than 10,000 individuals/m² in early April. Edrees (2009) recorded that about 115 mites/g of dust and 90 mites/g of dust was extracted from carpet floor of bedroom and living room of healthy persons homes in middle region of Jeddah respectively. However in the same area carpets from the bedroom and living room floors in asthmatic person homes were found to contain 321 mites/g of dust and 593 mites/g of dust respectively. Densities above 100 mites/g of dust are considered as a risk factor for sensitization to allergies such as rhinitis, conjunctivitis, atopic eczema and asthma, whereas 500 mites/g of dust is a major risk factor in acute asthma in those allergic to HDM (Korsgaard, 1983; Arlian et al., 1992; Service, 2004; Soltani et al., 2011).

Most surveys of house dust mite fauna conducted around the world report that the allergy-producing mites are worldwide species that occur in homes, schools, churches, day care centers, office workplace; seats in automobiles; clothes; stuffed toys, banks; libraries, museums, hotels and ski lodges and other public places (Arlian et al., 2002).

With respect to mites found in dwellings a survey of 41 dwellings in upper Silesia, Poland Solarz (1998) found the most to be infected with both

D. farinae and *D. pteronyssinus*. The former was the most abundant species overall, but in some dust samples, *D. farinae* was the predominant species (33.3 %) while in other samples *D. pteronyssinus* was more prevalent (27.5%). In some cases both species were equally prevalent. **Soleimani and Rafinejad (2008)** studied the fauna of house dust mites in hotels an inns of Bandar Abbas Iran, they indicated that the rate of house dust mites infections were 91.8, 85.7; 8.2, 10.9 and 0, 3.4% for *D. pteronyssinus*, *D. farinae* and *Cheyletus malaccensis*, respectively.

It is important to know the major mite breeding locations and which mite species are present in a public places when performing diagnostic testing prescribing immunotherapy. Although the presence of numerous dwellings dorms in Jeddah city western Saudia Arabia due to the religious tourism, no study on such medically important organisms have been conducted about the distribution, abundance and diversity in such public buildings. Accordingly this study was achieved in Jeddah city to test the null hypothesis that the different level of the dorms has a real effect on the quantitative and qualitative existence of the house dust mites, hence on the identification of the most important factors that control the distribution and colonization of such microarthropod organisms.

2. Materials and Methods

The present study was conducted at Jeddah city, western Saudi Arabia. The house dust mite samples were collected from 12 dorms (6 hotels and 6 motels). Using a vacuum cleaner (Boch 191 T) with disposable bag, dust was sampled from known area of carpet floor (4 m² for 5 min.) from six randomly selected rooms inside each dorm. The samples were collected twice a month along three months, Decembre, January and February, 2009. Mites were separated using modified Berleses funnel as recommended by **Al-Assiuty et al.(1993)** and **Edrees, 2009**.

Site description:

12 dorms of Jeddah city were tested. The city is located in a coastal region. It has a hot and humid climate. The tested dorms represented two levels:

The lower level group "Motels"

Six motels were selected. These were in "Slums" i.e. areas of a low quality living conditions, at Al- Hendawya and Bab Sherif areas, as here the buildings were more than 25 years old. The room temperatures in these buildings ranged between 24-26 °C. the humidity level ranged between 72- 75 %. The buildings usually comprised of three floors and the floors were made of cement covered with old chappy

rugs. The rug thickness was 3 centimetres. Each room contained 4 wood beds. During the study season the average number of the dwellers was almost 335 person per motel per month. Some of the rooms contained fans, while others contained old fashioned air conditions. The average amount of dust collected each time ranged between 5- 10 g/m². Cleaning was done once or twice a month, using vacuum cleaners, however without using any detergents either nor the floors or the furnitures.

The higher level group "Hotels"

This group comprised six hotels, these were almost four-star-hotels in semi-publio areas, not so far from Bab-Sherif area. The buildings ranged between 10- 15 years of age. The room temperature ranged between 22- 25 °C, and the humidity level ranged between 65- 70 %. Each building comprised of 3 floors, and the floors were made ceramic covered with carpets of 4 cm thickness. Each room contained 4 wood beds. The average number of the dwellers was 180 person per hotel per month. The rooms contained modern air conditions. The average amount of dust collected was 2 g/m². Cleaning was done on weekly regular basis using vacuum cleaners, detergent and liquid cleaners were usually used for cleaning.

Statistical analysis

The pooled data (count per 4m²x 6 rooms x 3 months) was determined per 50 gram of dust. Data of population densities were logarithmically transformed to achieve homogeneous variance. Means of house dust mite density between and within the two levels of the chosen dorms were compared by non-parametric Kruskal- wallis test. Bray- Curtis similarity index was used to measure the degree of overlap between house dust mite compositions in different dorms (**Krebs, 1999**). This index was calculated for all building pairs using the pooled community data per dwelling. To test if the mite assemblage was affected by the environmental variables and to determine which parameter(s) were responsible a PCA bi-plot of samples and species was made and environmental variables were included.

3. Results

All house dust mite species extracted from the two chosen groups of dorms were counted and identified. Tables 1&2 list the species composition per building. Ten species of HDMS were represented at the 12 sampling sites. The mite assemblage in motels was dominated by *Dermatophagoides pteronyssinus* (23.65 % of the total individuals) and in hotels mite collection was co-dominated by *Dermatophagoides pteronyssinus* (27.6% of the total

individuals) and *Dermatophagoides farinae* (21.8 % of the total individuals) (Tables 1&2 and Fig. 2). All the recorded species occurred at all sites and there was no difference in species richness and species diversity among the dorms of the same level, motels or hotels. However, species richness differed significantly among the two levels of dorms (Tables 1&2).

The density of the collected HDM from motels differed significantly ($P < 0.01$) as compared with that of recorded from hotels. Since the mean total individuals in motels was 5012 ind/50 g of dust correspond to 2149 ind/50 g of dust in hotels. Kruskal- Wallis test also was applied to the data pooled overall sampling months. This showed no significant differences ($P > 0.05$) between dorms of the same level, with exception of dorms H5 and H6 in hotel group and dorms M3 and M6 in motel group, where densities found to be significantly differed, since the least population densities were achieved in these dorms (Fig. 1).

Similarity in species composition between pair wise assemblages was analysed using the Bray-Curtis similarity index. Table 3 shows a strong overlapped figures between dorm pairs within the same level. The Bray-Curtis similarity index ranged from 0.74 to 0.93 within hotels and from 0.79 to 0.94 within motels. However, the Bray-Curtis similarity index between communities at different levels of dorm pairs was significantly lower (similarity ranged from 0.46 to 0.75) than within the same level.

In order to evaluate the structure of the house dust mite assemblages, further HDM species were numerically arranged in descending order and a rank abundance curves (Figs. 3a, 3b and 3c) were made for both levels of dorms. Figs. 3 a&b represents the data of the higher and lower level of dorms (hotels and motels). There was a linear decrease of log abundance with species rank, which is consistent with the geometric series model for community structure. Figure 3c indicates the rank abundance lines of all chosen dorms. It was clearly that the bundle of lines does not functionally separate according to the differences between dorms, this may indicates that there is no effect on the dominance structure of mite assemblages.

To describe the relationships among the number of individuals of every dominant mite species (4 species from hotels and 5 species from motels) and environmental variables; i.e. occupant density, age of building, relative humidity, dust quantity, cleaning and carpet sickness, an ordination diagram using PCA was made (Fig. 4). Data show a strong positive association of *Dermatophagoides pteronyssinus* with carpet sickness and cleaning manner. However, *Aleuroglyphus ovatus* showed a positive correlation with occupant density, relative humidity, dust quantity and building age. Little effect of the chosen factors on *Dermatophagoides farine* could be observed.

Figure 5 shows a biplot of the first two axes of the PCA, position of the sampling sites and their associations with the five dominant mite species in both levels of dorms. The two arbitrary curves in the figure separated mostly between hotel-group (1-6 open circles), right area of the graph and motel-group (7-12 open circles) left area of the graph. Also, between the position of the five dominant species (open triangles), the overlapped area (shaded area) comprised the shard four dominant species in both levels of dorms these are: *Dermatophagoides pteronyssinus*, *D. farinae*, *Cheyletus malaccensis*, *Aleuroglyphus ovatus*. The fifth dominant species *Suidasia nesbetti* lies out of overlapped area to the left side graph where it was more associated to the lower level of dorms (motels). It is interesting to note that the functional position of each studied dorm among the graph (Fig. 5) was the total number of the individuals of the dominant species in each dorm of hotels and motels.

As for the association between the abundance of HDM individuals with the environmental variables figure 6 shows that buildings exposed to a regular cleaning manner using vacuum cleaners, and/or detergent and liquid cleaners (hotels 5 and 6 and motels 9 and 12, Fig. 6) showed the least number of house dust mites. However, the largest individual number in motel 10 (Fig. 6) was found to be strongly associated to the dust quantity, high relative humidity and high resident number.

Table 1. List of house dust mite species and the total number of individuals /sample (50g of dust) and their relative contributions in the six hotels.

Species	H1	RC %	H2	RC %	H3	RC %	H4	RC %	H5	RC %	H6	RC %	Total	RC %
<i>Dermatophagoides pteronyssinus</i>	659	27.98	515	21.4	606	25.95	580	24.59	748	41.6	448	27.33	5927	27.58
<i>Dermatophagoides farinae</i>	500	21.23	667	27.71	580	24.84	457	19.37	314	17.46	287	17.51	4675	21.76
<i>Cheyletus malaccensis</i>	282	11.97	337	14	267	11.43	317	13.44	95	5.284	193	11.78	2485	11.56
<i>Suidasia nesbetti</i>	267	11.34	235	9.763	264	11.31	257	10.89	146	8.12	133	8.115	2170	10.1
<i>Carpoglyphus lactis</i>	150	6.369	139	5.775	204	8.737	112	4.748	132	7.341	164	10.01	1502	6.988
<i>Blomia tropicalis</i>	141	5.987	157	6.523	111	4.754	127	5.384	100	5.562	115	7.016	1252	5.825
<i>Aleuroglyphus ovatus</i>	129	5.478	148	6.149	94	4.026	175	7.418	73	4.06	58	3.539	1128	5.251
<i>Acarus siro</i>	117	4.968	109	4.528	80	3.426	148	6.274	113	6.285	183	11.17	1250	5.817
<i>Blomia freeman</i>	63	2.675	52	2.16	70	2.998	115	4.875	47	2.614	30	1.83	623	2.924
<i>Tyrophagus putrescentiae</i>	47	1.996	48	1.994	59	2.527	71	3.01	30	1.669	28	1.708	477	2.195
Total	2355	100	2407	100	2335	100	2359	100	1798	100	1639	100	2149	100
Shannon diversity index(H')	H' = 2.014		H' = 2.003		H' = 1.991		H' = 2.096		H' = 1.849		H' = 2.038		H' = 2.027	
Equitability	J = 0.874		J = 0.870		J = 0.865		J = 0.910		J = 0.803		J = 0.885		J = 0.880	
Species richness	SR = 1.159		SR = 1.156		SR = 1.160		SR = 1.159		SR = 1.201		SR = 1.216		SR = 1.173	

Table 2. List of house dust mite species and the total number of individuals /sample (50g of dust) and their relative contributions in the six motels.

Species	M1	RC %	M2	RC %	M3	RC %	M4	RC %	M5	RC %	M6	RC %	Total	RC %
<i>Dermatophagoides pteronyssinus</i>	1258	23.73	1465	27.05	1028	26.35	1231	21.29	1279	23.86	8526	19.76	11865	23.65
<i>Dermatophagoides farinae</i>	1092	20.6	9859	18.1	6453	16.5	28	21.4	9928	18.5	7551	17.5	9518	18.9
<i>Cheyletus malaccensis</i>	6014	11.3	5004	9.23	5162	13.2	8173	14.1	4592	8.56	7134	16.5	6010	11.9
<i>Suidasia nesbetti</i>	8454	15.9	7273	10.4	4086	10.4	8572	14.8	9224	17.2	5427	12.5	7168	14.3
<i>Carpoglyphus lactis</i>	1698	3.18	4492	3.48	1365	3.48	3185	4.96	2662	4.96	1252	2.90	2438	4.86
<i>Blomia tropicalis</i>	7910	1.49	824	1.51	426	1.07	5910	0.89	485	1.53	661	1.53	6267	1.25
<i>Aleuroglyphus ovatus</i>	5385	10.1	4483	8.27	4584	11.7	5827	10.0	6378	11.8	4239	9.81	5143	10.2
<i>Acarus siro</i>	2605	4.90	2836	5.22	2214	5.66	2543	4.39	2786	5.18	2792	6.47	2625	5.23
<i>Blomia freeman</i>	1429	2.67	1414	2.60	1275	3.25	921	1.59	1411	2.52	1098	2.52	1253	2.50
<i>Tyrophagus putrescentiae</i>	3175	5.98	3357	6.18	3217	8.22	3307	5.70	3393	6.32	4477	10.3	3482	6.94
Total	5301	100	5415	100	3902	100	5782	100	5361	100	4311	100	5012	100
Shannon diversity index(H')	H' = 2.024		H' = 2.051		H' = 2.049		H' = 2.023		H' = 2.035		H' = 2.083		H' = 2.056	
Equitability	J = 0.879		J = 0.891		J = 0.890		J = 0.879		J = 0.884		J = 0.905		J = 0.893	
Species richness	SR = 1.049		SR = 1.047		SR = 1.088		SR = 1.048		SR = 1.048		SR = 1.075		SR = 1.056	

Table 3. The degree of overlap between house dust mites composition in different dorms (6 hotels and 6 motels) calculated for all building pairs using Bray-Curtis similarity index.

Dorms	H1	H2	H3	H4	H5	H6	M1	M2	M3	M4	M5	M6
H1		0.903	0.93	0.921	0.823	0.781	0.615	0.606	0.751	0.579	0.610	0.707
H2			0.895	0.890	0.742	0.761	0.625	0.615	0.754	0.588	0.620	0.717
H3				0.889	0.785	0.771	0.612	0.603	0.743	0.575	0.604	0.703
H4					0.775	0.776	0.616	0.607	0.740	0.571	0.605	0.697
H5						0.829	0.507	0.499	0.631	0.474	0.502	0.589
H6							0.468	0.465	0.575	0.442	0.468	0.531
M1								0.912	0.847	0.938	0.943	0.843
M2									0.832	0.883	0.922	0.820
M3										0.799	0.830	0.892
M4											0.917	0.821
M5												0.813
M6												

- Within the same level (hotels H1- H6)
- Within the same level (motels M1- M6)
- Between the two levels motels and hotels

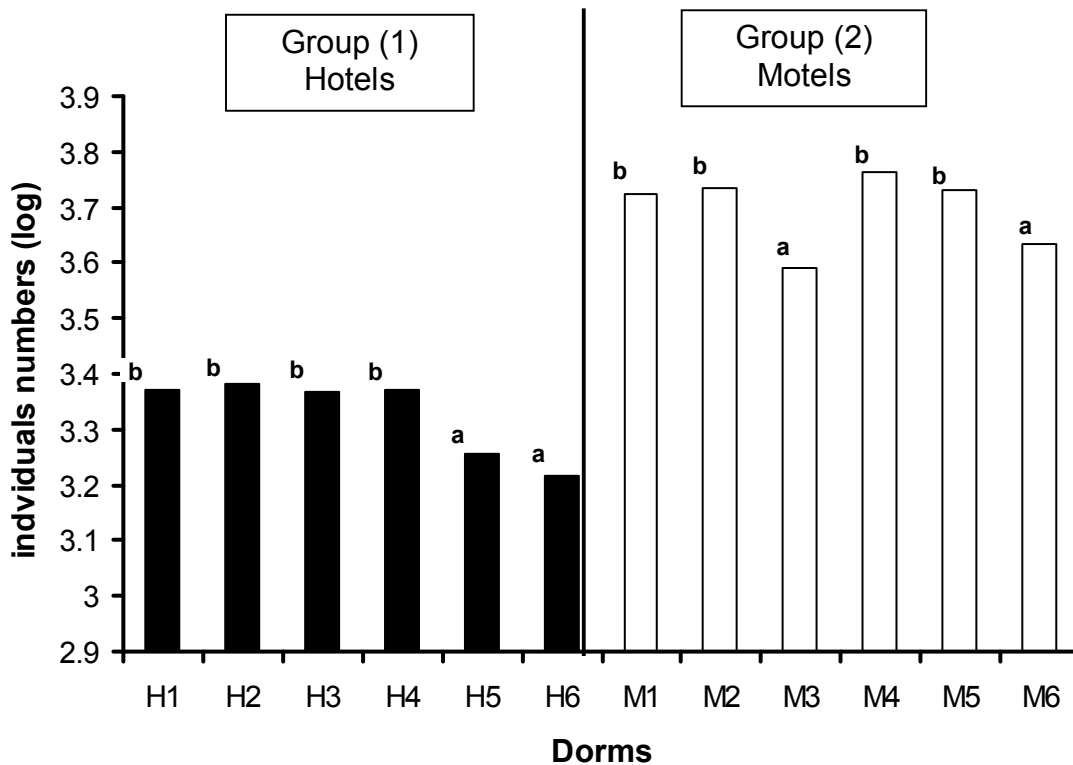

Figure 1. The population density per 50 gram of dust of the total mites (10 species) in the 6 motels and 6 hotels (H1- H6) and six motels (M1- M6). The same letters of a and b indicate insignificant difference between each pairs among each group and vice versa

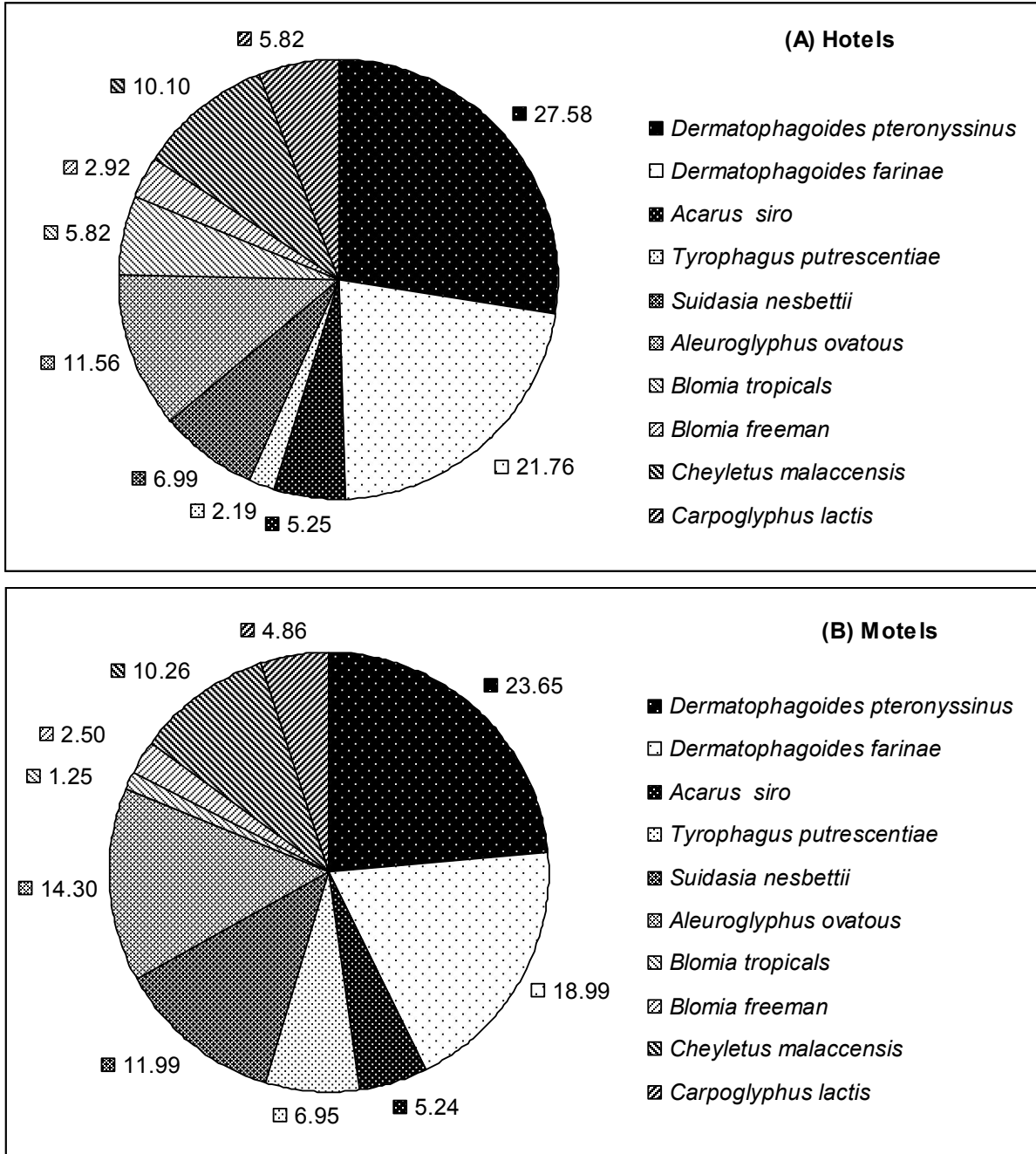

Figure 2. The relative occurrence of the ten species of the house dust mite individuals from (A) Hotels and (B) Motels.

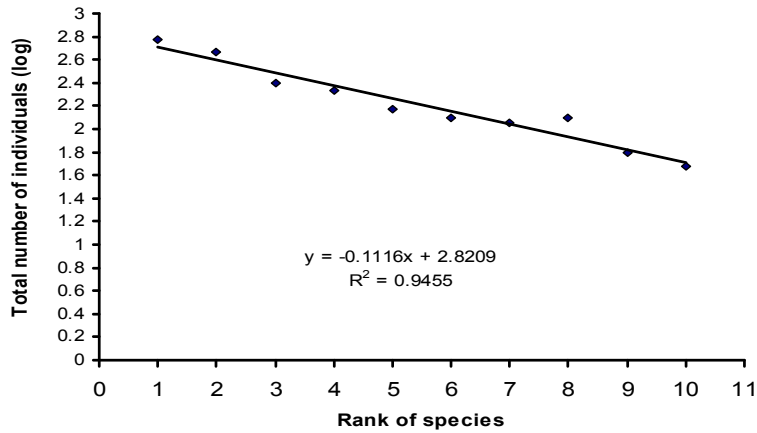

Figure 3a. Rank abundance of the total house dust mite assemblages at hotels

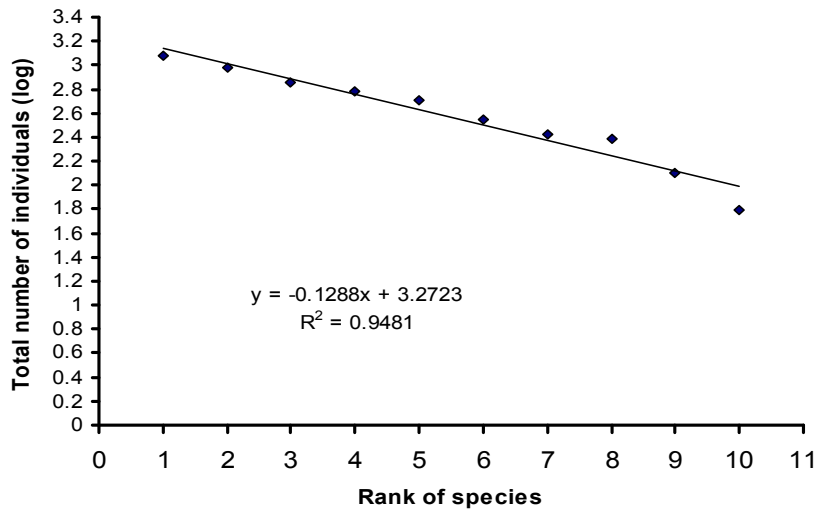

Figure 3b. Rank abundance of the total house dust mite assemblages at Motels

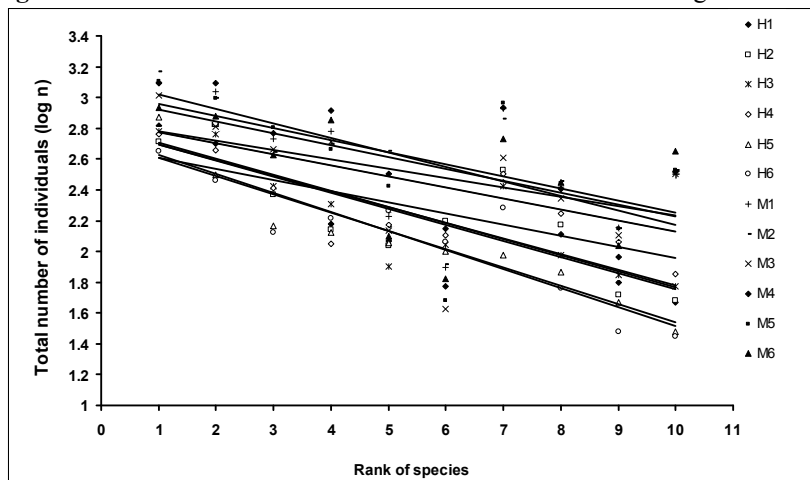

Figure 3c. Regression lines for the rank abundance relationships of house dust mite communities at all 12 dorms (6 hotels (H1-H6) and 6 motels (M1 – M6)).

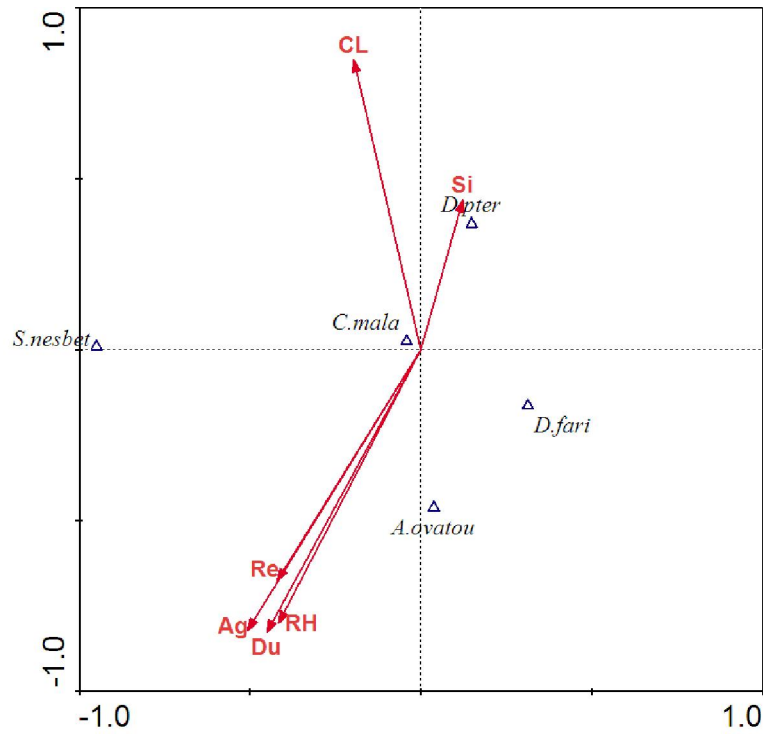

Figure 4. Ordination of the truncated house dust mite assemblages, Showing the position of the five dominant species and their associations with six environmental variables (*Re*= occupant density, *Ag* = age of building, *RH*= relative humidity, *Du*= dust quantity, *CL*= cleaning and *Si*= Carpet sickness). Species are indicated by open triangles and environmental variables by arrows.

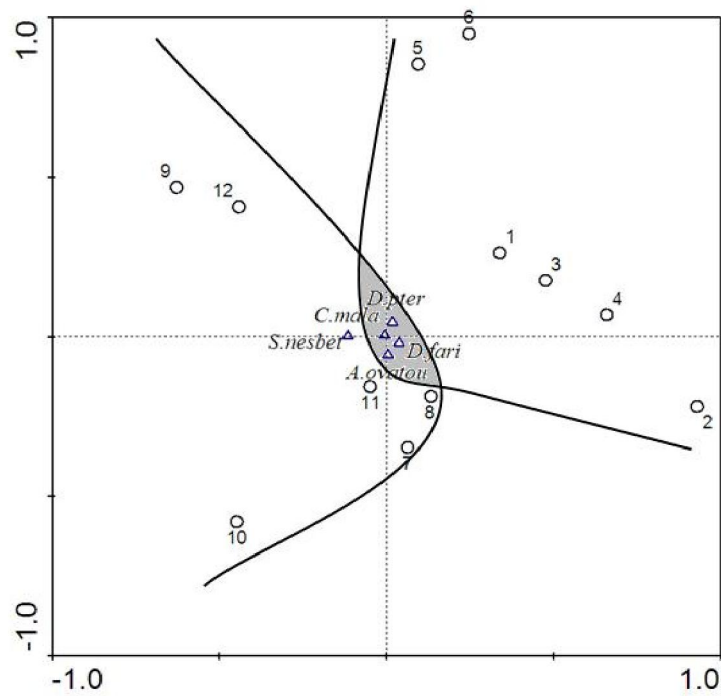

Figure 5. Shows a biplot of the first two axes of PCA position of the sampling sites and their associations with the dominant mite species in both levels of dorms for explanation legend figure 6.

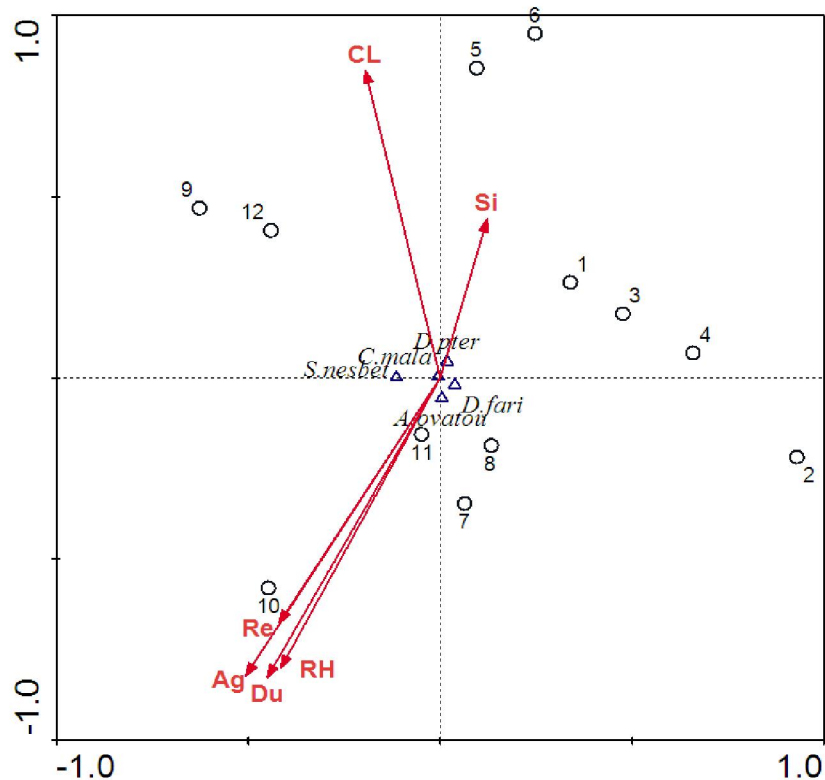

Figure 6. Ordination of the truncated house dust mite assemblages (five dominant spp.) Showing the position of (sample sites) and their associations with environmental variables and the position of the five dominant species. Sites are indicated by open circles (1- 6 hotels, 7-12 motels). Mite species by open triangular and environmental variables by arrows. for explanation legend figure 4.

4. Discussion

The house dust mite fauna in the hotels and the motels had not been studied previously in Saudi Arabia. In this study ten HDM species in the two levels of dorms were recorded. The most common allergy-causing mites that occur in different studied dorms were; *Dermatophagoides pteronyssinus* (23.7% in the motels and 27.6% in the hotels) and *D. Farinae* (18.9% in the motels and 21.8% in the hotels) but other species were also well represented especially *Cheyletus malaccensis*, *Aleuroglphus ovatus* and *Suidasia nesbetti*. **Arelian et al. (2002)** indicated that most surveys of mite fauna conducted around the world report that the two species *D. pteronyssinus* and *D. farinae* were usually both present in a region and occur together in homes although one species was usually the more prevalent. **Solaz (1998)** surveyed 41 dwellings in upper Silesia, Poland. It was found that the most surveyed dwelling were co-infested with both *D. pteronyssinus* and *D. farinae*. The latter species was the most abundant overall, but in some dust samples it was the predominant species (33.3%) while in other samples *D. pteronyssinus* was more prevalent (27.5%). In the

most recent study, the rate of house dust mite infections in hotels and inns of Bandar Abbas Iran for *D. pteronyssinus*, *D. farinae* and *Cheyletus malaccensis* were 91.8, 85.7; 8.2, 10.9 and 0, 3.4% respectively (**Soleimani and Rafinejad, 2008**).

In the current study as mentioned above *Cheyletus malaccensis* was found to reach a high level of relative dominance (11.6% in the hotels and 12% in the motels). However, **Soleimani and Rafinejad (2008)** found this species among three mite species in relatively low number as a rare species in the inns in Bandar Abbas- Iran. It could be indicated that this mite has been reported to be predaceous mite on several other mite species. It is suggested that the pattern of the high number of its representatives in the present data match the high species richness (9 spp.) that may support a successful life for such predatory mite via a more diverse prey.

The data of this study showed that the motels appear to have the largest abundance of the total mites (5012 ind/50 g of dust) in correspond to 2149 ind/50 g of dust in the hotels. Obviously the two levels of dwellings surveyed in this study differed not

only in mite abundance but also in various other habitat factors known to influence HDM developments such as the cleaning and sanitation manner, dust quantity, resident density and their economic status, relative humidity and ventilation, floor covering. Numerous studies demonstrate the relation between HDM occurrence and building disinfectants (Schober *et al.*, 1987) vacuuming and ventilation (Tovey and Marks, 1998) and humidity (Lintner *et al.*, 1993). Tovey *et al.*, 1998 stated that dry vacuum cleaners are useful to pick up excess dust and to reduce reservoirs allergy-causing mites.

With respect to the impact of the resident density and their economic status on the house dust mite abundance. Valero and Serrano (2004) indicated that house dust mites feed mainly on flakes of human skin. A single adult person sheds between 0.5-and 1 g per day, enough to feed 100.000 house dust mites a day. On the other hand, in the most recent study Soltani *et al.* (2011) mentioned that HDM frequency different between eastern and western areas in Iran, this pattern matches the economic status of residents in these areas. This may indicate direct impact of economic condition and life style on the mite contamination rate. The fact that live mites were found on clothing (Neal *et al.*, 2002) is evidence that clothing is a vehicle for mite dispersal and colonization in such public dorms specially the low level buildings (motels).

It is also evident that carpets serve as a major reservoir of many indoor allergy-producing mites. On sampling with a vacuum cleaner carpet yield more dust, this will reduce mite abundance. Cleaning on weekly regular basis using detergent and liquid cleaners, this achieves a significant reduction in such mites. A dry indoor relative humidity through a good ventilation will reduce mite density.

In this study up to 66.6% of the motels had a population density of more than 100 individuals per 1 gram of dust, however non of the studied hotels was found to housed more than 50 individuals per 1 gram of dust. Densities above 100 mites per 1 gram of dust are consider as the threshold at which mite allergen concentration is clinically important (Korsgaard, 1983; Arlian *et al.*, 1992). This suggests that the most allergic genetically predisposed residents in the motels in Jeddah city are exposed to a risk factor for sensitization to allergens produced from mites.

Conclusion:

The level of dorms had a clear effect on the quantitative existence of the house dust mites but a qualitative effect cannot be identified. Also, it was speculated that the most frequent cleaning of as well as density and economic status of residents were the

main factors matched with a direct impact on the mite contamination rate of dorms.

Corresponding author

Nada Othman Edrees
Department of Biology, Faculty of Science for Girls,
king Abdulaziz University. Jeddah, Kingdom of
Saudi Arabia.
nada.algalb@hotmail.com; nedrees@kau.edu.sa;
dr_nada_edrees2006@yahoo.com

References

- Al-Assiuty M. I. M., Bayomi B. M., Khalil M. A., and Van Straalen N. M. (1993): The influence of vegetations type on seasonal abundance and species composition of soil fauna at different localities in Egypt. *Pedobiologia*, 37: 210 – 222.
- Arlian L. G. (1992): Water balance and humidity requirements of house dust mites. *Exp Appl Acarol.*, 16: 15 – 35.
- Arlian L. G. (2000): Mites are ubiquitous: are mite allergens, too? *Ann Allergy Asthma Immunol.*, 85: 161 – 163.
- Arlian L. G. (2002): Arthropod allergens and human health. *Ann Rev Entomol.*, 47: 395 – 433.
- Arlian L. G., Bernstein D., Bernstein I. L., Friedman S., Grant A. (1992): Prevalence of dust mites in homes of people with asthma living in eight different geographic areas of the United States *J Allergy Clin Immunol.*, 90: 292 – 300.
- Arlian L. G., Morgan M. S., and Neal J. S. (2002): Dust mite allergens: Ecology and distribution. *Current Allergy and Asthma reports*, Current Science Inc., 2: 401 – 411.
- De Boer R. (1990): The control of house dust mite allergens in rugs. *J Allergy Clin Immunol.*, 86: 808 – 814.
- De Boer R. and Kuller K. (1995): Winter survival of house dust mites (*Dermatophagoides* spp) on the ground floor of Dutch houses, *Proc. Exp. Appl. Entomol. NEV Amsterdam*, 6: 47 – 52.
- De Boer R., Wietske A. D., Hoeven V., and Kulle K. (1999): The control of house dust mites in rugs through wet cleaning *Mo. Sby- Year Book, Inc. Amsterdam*, pp: 1214 – 1217.
- Edrees N. (2009): Distribution dynamics of dust mites in two locations of patient homes with respect to the allergical kind. *American- Eurasian J. Agric. & Environ. Sci.*, 6(6): 680 – 688.
- Korsgaard J. (1983): House dust mites and absolute indoor humidity. *Allergy*, 38(2): 85 – 92.
- Krebs C. H. (1999): *Ecological methodology* 2nd Ed Addison Wesley Longman, Inc. Jim Green.
- Lintner T. J., and Brame K. A. (1993): The effect of season, climate and air conditioning on the prevalence of *Dermatophagoides* mite allergens in

- household dust. *J. Allergy Clin Immunol.*, 91: 862 – 867.
- Neal J. S., Arlian L. G., and Morgan M. S. (2002): Relationship among house dust mites, *Der 1*, *Fel d1*, and *Can f1* on clothing and automobile seats with respect to densities in houses. *Ann Allergy Asthma Immunol.*, 88: 410 – 415.
- Schober G., Wetter G., Bischoff E., Van Bronswijk J. E., and Kniest F. M. (1987): Control of house dust mites *Pyroglyphidae* with home disinfectants. *Experimental & Applied Acarology*, 3: 179 – 189.
- Service M. W. (2004): *Medical entomology for students*, 3rd edn. Cambridge University Press, Cambridge.
- Solarz K. (1998): The allergenic acarofauna of house dust from dwelling, hospitals, libraries and institutes in Upper Silesia (Poland). *Ann Agric Environ Med.*, 5: 73 – 85.
- Soleimani M., and Rafinegad J. (2008): House dust mite contamination in hotels and inns in Bandar Abbas, South of Iran. *Iran J Environ Health Sci Eng.*, 5(3): 207 – 210.
- Soltani A., Azizi K., Saleh V., and Dabghmanesh T. (2011): The fauna and distribution of house dust mites in residential homes of Bandar Abbas District, Southern Iran. *Exp. Appl Acarol.*, 54: 269 – 276.
- Tovey E., and Marks G. (1998): Methods and effectiveness of environmental control. *J Allergy Clin Immunol.*, 103(2)1: 179 – 191.
- Valero A., and Serrano C. (2004): Are environmental controls effective for house dust mite allergies? *Arch Bronconeumol.*, 40(9): 389 – 391.
- Van de Lustgraat B. (1978): Ecological relationships between xerophilic fungi and house dust mites (Acarina: *Pyroglyphidae*). *Decologia (Berlin)*, 33: 351 – 359.

11/20/2012

An improved Artificial Neural Network based model for Prediction of Late Onset Heart Failure

Nader Salari^{1,2}, Shamarina Shohaimi¹, Farid Najafi², Meenakshii Nallappan¹,
Isthriyaygy Karishnarajah³

¹Department of Biology, Faculty of Science, University Putra Malaysia, Serdang, Selangor, Malaysia.

²Department of Biostatistics and Epidemiology, School of Public Health, Kermanshah University of Medical Sciences, Kermanshah, Iran.

³Department of Mathematics, Faculty of Science, University Putra Malaysia, Serdang, Selangor, Malaysia.

Corresponding Author E-mail: nader.salari.1344@gmail.com

Abstract: Background and Objective: The present study aims to present an artificial neural network (ANN)-based model for prediction of Late Onset Heart Failure (LOHF) in patients, with no previous Heart Failure (HF) history, who experienced non-fatal, first-ever Acute Myocardial Infarction (AMI) without previous history of heart failure. **Methods:** Two models of multilayer perceptron (MLP) and Radial Basis Function (RBF) neural network approaches based on decision support system were developed. The MLP model was used to optimize the predicting algorithm based on the conjugate gradients descent method. To design the RBF network, K-Means clustering technique was used to select the centers of RBFs, and k-nearest neighbourhood to define the spread and forward selection for determining the optimum number of RBFs. To assess the generalization of the network, K-fold cross-validation test was used. A total of 3,109 medical records containing 19 main clinical parameters were used to train and test the networks. **Results:** The findings indicate a reliable performance of the proposed system. The MLP based model yields a sensitivity, specificity, and an area under the receiver/relative operating characteristic (ROC) curve (AUC) of 87.1%, 90%, and 0.887 ± 0.02 , respectively. However, the RBF network shows the above parameters as 84.4%, 94.3%, and 0.905 ± 0.017 , respectively. **Conclusions:** The proposed intelligence system achieved a high degree of diagnostic accuracy (92.9% for MLP and 93.7% for RBF) indicating its high efficiency for clinical diagnosis of LOHF.

[Nader Salari, Shamarina Shohaimi, Farid Najafi, Meenakshii Nallappan, Isthriyaygy Karishnarajah. **An improved Artificial Neural Network based model for Prediction of Late Onset Heart Failure.** *Life Sci J* 2012;9(4):3684-3689]. (ISSN: 1097-8135). <http://www.lifesciencesite.com>. 546

Keywords: Heart failure, late-onset heart failure, acute myocardial infarction, artificial neural network, multilayer perceptron, radial basis function.

1. Introduction

Heart failure (HF) is defined as an inability of the heart to supply sufficient blood flow as well as oxygen to meet the body's requirements. There are several risk factors can cause HF such as ischemic heart disease because of heart valve dysfunction, hypertension, heart attack (myocardial infarction), and cardiomyopathy. Heart attack or acute myocardial infarction (AMI) is simply cellular death of part of heart muscle due to the interruption of blood flow, resulting in shortage of oxygen in myocardium. Without prompt treatment, this condition is potentially fatal (Nadar et al., 2005, Bordier, 2009). It is noteworthy that over one million cases of hospital discharge with HF were registered in the United States in 2005, illustrating a 171% rise compared to 1979 (Cohn et al., 2000). Furthermore, approximately 3.8 million cases of HF were diagnosed in American hospitals in 2004 (Gheorghide and Pang, 2009).

The high rate of morbidity and mortality following an episode of heart attack is a major concern of physicians and cardiologists necessitating development of an efficient approach to prevent the heart attack or

control its consequent complications through analysis of information obtained from patients. This process typically consists of numerous clinical visits, sometimes involving many paraclinical assessments, as well as the physicians own clinical experiences and insight to predict the event.

Nevertheless, there is a growing effort to find more accurate and faster solutions for prediction at the macro level. In addition to physicians' efforts, some prediction models, based on mathematical and statistical methods, have been developed during the recent years. The most commonly used methods include Bayesian network, logistic regression, and neural networks (Barlow et al., 1984, Fabbri et al., 2008, Hsu et al., 2005, Lang et al., 1997, Pang et al., 2007, Smits et al., 2010). Particularly, artificial neural networks (ANNs) have been successfully used for surgical decisions and mortality prediction based on initial clinical data (Li et al., 2000).

Although the characteristics of HF have been studied extensively (Bordier, 2009, Hamner and Ellison, 2005, Najafi et al., 2007, Najafi et al., 2008), there are only few studies conducted on the prediction

of HF using ANN in MI patients (Eggers et al., 2007). Furthermore, previous studies showed that an efficient prediction of HF following AMI should be based on the time of its occurrence.] The importance of time-based prediction is originated from the different mechanisms responsible for early-onset HF (EOHF) (HF complicating an index AMI within the first 28 days) and late-onset HF (LOHF) (HF developing beyond 28 days after an index AMI) (Cohn et al., 2000, Stone et al., 1988). The present study was mainly aimed to propose an ANN-based model for prediction of Late Onset Heart Failure (LOHF) in patients, with no previous HF history, who experienced non-fatal, first-ever AMI without previous history of heart failure.

2. Materials and Methods

Study populations and data collection

The Perth MONItoring trends and determinants of Cardiovascular disease (MONICA) Register covered the entire residents of the Perth Statistical Division, in an effective manner the metropolis district of Perth, aged 25-64 years (Tunstall-Pedoe et al., 1994). We have been using the Western Australian Linked Database System (WALDS)(Holman et al., 1999) and MONICA data from Perth, Western Australia. The register consisted of all main coronary events that have occurred, and used the 'cold pursuit' method to clarify non-fatal potential instances of AMI through surveillance of hospital discharge codes(Tunstall-Pedoe et al., 1994). Data were extracted and compiled from medical records for each aspect of hospitals with International Classification of Diseases (9th revision, clinical modification) (ICD-9-CM) code for AMI or somewhat acute coronary heart disease (codes 410 and 411, respectively). The analysis relates to all patients with events who met the following criteria: the patients had no history of previous HF or AMI and no evidence of EOHF; the event fulfilled the MONICA criteria for 'definite AMI' (Stone et al., 1988); and the patients were alive 28 days after the onset of AMI symptoms. Using the Western Australian Linked Database System WALDS (Holman CD et al., 1999), we followed up all patients included in our study sample for a subsequent admission to the hospital with a diagnosis of HF. To capture all cases of HF (even those complicating a recurrent AMI), we defined a patient as having HF when he/she had an electronic record for a new hospital admission including the ICD-9-CM code for HF (428) in either the first or the second diagnostic position. We refer to such cases as late-onset HF, as opposed to EOHF indicating HF complicating the first-ever AMI within the first 28 days.

A total of 19 variables including demographic information, clinical history, symptoms, lab results and physical examinations were collected from each patient's paper record (3109 number of the patients

were used (2652 male and 457 female)) and then normalized under the supervision of cardiologists (see Table 1). Patient records often contain missing values. In this study, missing values were replaced with the normal values assuming that if the readings were abnormal they would have been recorded.

Table 1. Characteristics of patients with first-ever non-fatal myocardial infarction, Perth MONICA

Variables	Comment
-Basic information	
Age	Normalize on (0 1)
Sex	Male=0, Female=1
-Medical history	
History of diabetes	Absence = 0, presence = 1
History of hypertension	Absence = 0, presence = 1
History of angina	Absence = 0, presence = 1
Current smoker	Absence = 0, presence = 1
Recurrent MI	Absence = 0, presence = 1
-Presenting characteristics	
Mean of CPK ratio	Normalize on (0 1)
Systolic blood pressure	Normalize on (0 1)
Pulse	Normalize on (0 1)
Shock	Absence = 0, presence = 1
Syncope	Absence = 0, presence = 1
ALVF	Absence = 0, presence = 1
Complication of infarction	Absence = 0, presence = 1
Length of hospital admission	Normalize on (0 1)
-ECG findings	
ST-elevation	Absence = 0, presence = 1
ST- depression	Absence = 0, presence = 1
Q-wave	Absence = 0, presence = 1
Anterior MI	Absence = 0, presence = 1

Multilayer perceptron model

The ANNs are strong tools for prediction, classification, generalization, simulation, etc. in different applications. Furthermore, neural network approach is a way of modelling data, based on computer learning which are basically trained to perform complex functions in various fields of applications including pattern recognition, identification, classification, speech, vision, control systems, and etc.(Gallant and White, 1992) The multi-layer perceptron (MLP) networks are one of the most widely used neural networks consisting of a great deal number of processing elements called neuron. The neurons are connected to each other through a set of weights. These weights are adjusted based on an error-minimization technique called back-propagation rule. A diagram of the used MLP model with one hidden layer is shown in Fig. 1. The specified network consists of three layers named as input layer, hidden layers and output layer. Each layer has its own number of neurons. The input to the node l in the hidden layer is given by

$$\eta_{in_l} = \sum_{u=1}^q (x_u v_{ul}) + \theta_l ; \quad l = 1, 2, \dots, s \quad (1)$$

where s is the number of neurons in the hidden layer, q is the number of neurons in the input layer, θ_l is the bias term of the l^{th} neuron of hidden layer, and v_{ul} is the

weighting factor between u^{th} input neuron and the l^{th} hidden one. (Gallant and White, 1992). The output from l^{th} neuron of the hidden layer is given by

$$\eta_{out_l} = f_1(\eta_{in_l}) ; \quad l = 1, 2, \dots, s \quad (2)$$

where f_1 is the transfer function of the hidden layer. Some of the commonly used transfer functions are threshold, Gaussian, logarithm-sigmoid and tan-sigmoid functions. Because of the bipolar advantages, MLP neural networks often make use of the tan-sigmoid transfer function in the hidden layer; therefore, the output from l^{th} neuron of the hidden layers is given by

$$o_l = Tansig(\eta_{in_l}) = \frac{2}{1 + \exp(-2(\eta_{in_l}))} - 1 ; \quad (3)$$

$D_{o_l}: [-\infty \infty] \rightarrow R_{o_l}: [-1 1]$; activation domain $\approx [-2 2]$

The input of the j^{th} neuron in the output layer is given by

$$y_{in_j} = \sum_{u=1}^s (o_u w_{uj}) + b_j ; \quad j = 1, 2, \dots, m \quad (4)$$

where b_j is the bias term of j^{th} hidden neuron, w_{uj} is the weighting factor between u^{th} neuron of hidden layer and the j^{th} neuron of output layer, and m is the number of neurons in the output one (Taylor, 1997).

And then, the output of j^{th} neuron is represented as follows:

$$y_{out_j} = f_2(y_{in_j}) ; \quad j = 1, 2, \dots, m \quad (5)$$

where f_2 is the logarithm-sigmoid transfer function of the output layer.

$$Logsig(y_{in_j}) = \frac{1}{1 + \exp(-(y_{in_j}))} ; \quad (6)$$

$D_{f_2}: [-\infty \infty] \rightarrow R_{f_2}: [0 1]$; activation domain $\approx [-4 4]$

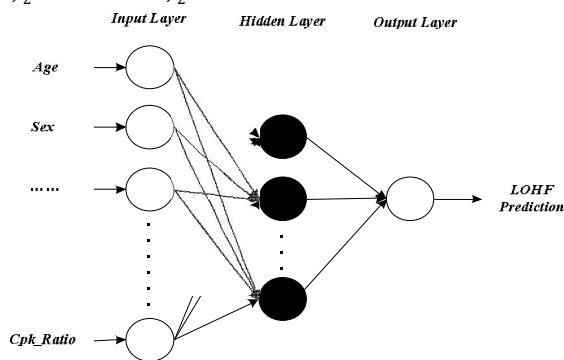

Fig 1. System architecture.

The training of a network is a process where the set of adjusted parameters (weights and biases) is optimized to make the best prediction of the target variable based on background variables. MLP networks are trained with the standard back-propagation algorithm (Gallant and White, 1992). Back-propagation algorithm basically consists of two steps: a forward step where the signal propagates through the computational units until it gets to the output layer and a backward step where all synaptic weights are adjusted accordingly to an error correction rule. In this method,

often the adjusted parameters are determined iteratively to achieve a minimum mean square error between the network output and the target values. In our study, a three-layer MLP network, with tangent-sigmoid transfer functions in the hidden layer as well as a logarithm-sigmoid transfer function in the output layer was constructed.

It should be noted that a complicated network with more neurons is capable of solving more sophisticated problems. However, increasing the number of neurons makes the system vulnerable to the noises present in the training data resulting in a condition called over-fitting. Therefore, a network with fewer neurons increases the generalization capability of the system as well as weights' size reduction and more convergence of the network to its desired output. On the other hand, a network with few neurons can't learn as good as it should. Therefore, there is a challenge between the power of generalization and preventing of over-fitting. Consequently, one of the main problems with implementation of an ANN model is selecting the correct number of the neurons. One method to determine the optimum number of the nodes in the hidden layer is implementing different networks with one to thirty nodes, and then the minimum error on test data calculates. Number of neurons with the minimum error on test data was chosen as the optimum network.

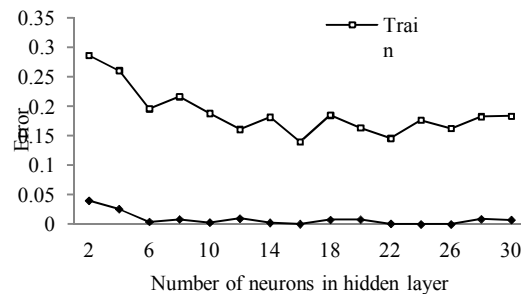

Fig 2 . Train and test errors of MLP vs. number of hidden nodes.

Radial Basis Function Model

This network also consists of input, hidden and output layers. Input to each hidden neuron is the distance between the network inputs and centre of that neuron's transfer function. The network's output is the weighted combination of hidden neurons' output. The network parameters are centre and spread of hidden layer's transfer functions and weights of output layer. There are different forms of transform functions but the most widely used one is the Gaussian function.

Setting the centers randomly to the training inputs is the simplest method of defining the centers but this approach is prone to overfitting. An alternative is to cluster the training patterns into groups according to some similarity measurement and then assigning nodes

to each cluster. The typical method to determine such clusters is the k means clustering algorithm. Since it is an unsupervised method and data belonging to two different groups can be clustered as one, application of supervised methods like genetic algorithm (Billings and Zheng, 1995), supervised fuzzy c-means (Pedrycz, 1998) decision tree (Kubat, 1998), have been investigated recently.

Although supervising methods like those mentioned can improve the RBF neural network classification performance, they are slow to train which can be a disadvantage comparing with the fast learning of the MLP achieved through combining an unsupervised with a supervised method is a disadvantage of RBF against the MLP approach. Forward selection was used to determine the number of hidden layer neurons where the number of neurons was changed from two to thirty and considering the error on test data, optimum number of neurons and therefore number of clusters were determined (Fig. 3). Spread or width of Gaussian transfer functions was determined from the *k*-nearest neighbour heuristic according to the following formula:

$$\beta = \left(\frac{1}{k} \sum_{j=1}^k \|c - c_j\|^2 \right)^{1/2} \quad (7)$$

where c_j is the *k*-nearest neighbour of *c*. $K = 2$ was used as suggested previously (Moody and Darken, 1988). Weights in the output layer were found using the pseudo inverse method.

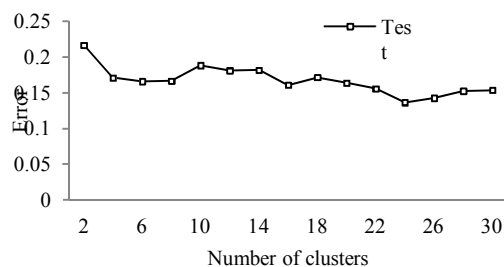

Fig 3. Test errors of RBF vs. number of clusters.

3. Results

Experimental Results and Performance Assessment

To estimate the performance of the model, a 10-fold cross validation method was used. The data set was randomly divided to 10 roughly equal parts (approximately 310 patients with 6218 data points per set). The network was trained on nine parts and tested on the remaining part. This procedure was repeated 10 times so the network error is the average of these 10 errors. To evaluate the performance of network, sensitivity and specificity were calculated. The values of sensitivity and specificity obtained for a test with continuous output depend on the particular cut-off value chosen to distinguish normal and abnormal

results. Selecting a threshold for a clinical decision support depends on the disease in question and the purpose of testing, if the disease is serious and lifesaving therapy is available, then falsely diagnosing a patient as healthy should be minimized (increasing sensitivity) and if disease is not serious and the therapy is dangerous, then falsely diagnosing a healthy individual as a patient should be minimized (increasing specificity). So sensitivity and specificity alone do not indicate the performance of an experiment and the chosen value of threshold is also effective. Altering the threshold value does not have any impact on the experiment and only provides a balance between sensitivity and specificity. Therefore, the best way to demonstrate the performance of a test is determining values of sensitivity and specificity for all cut off points obtained by an ROC curve.

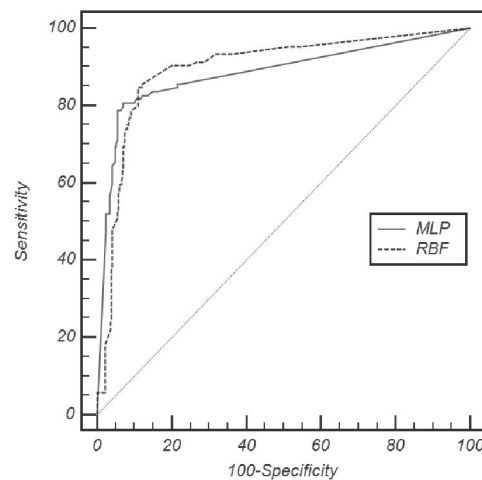

Fig 4. ROC curve comparison of MLP and RBF.

Table 2. Performance evaluation MLP and RBF networks

	Sensitivity (%)	Specificity (%)	PPV (%)	NPV (%)	AUC ± SE
MLP	87.1	90	88.4	86.2	0.887±0.020
RBF	84.4	94.3	93.1	87.7	0.905±0.017

The network output values range 0-1. Zero corresponds to non-LOHF and one to LOHF disease. The desired output was based on the final diagnosis of physicians according to the patients' record. MedCalc software (v11.1.6) was used to find the threshold value which maximizes both sensitivity and specificity (Moody and Darken, 1988). Application of MLP with 16 neurons in hidden layers resulted in sensitivity of 87.1%, specificity of 90% and ROC of 0.887 ± 0.02 and using RBF neural networks with 6 neurons in hidden layer resulted in specificity of 94.3%, sensitivity of 84.4% and ROC of 0.905 ± 0.017 (see Fig. 4-Table 2).

4. Discussion

As mentioned before heart attack is a major concern for physicians and cardiologists that leads to their efforts to prevent the complications through analysis of information obtained from patients to make sound decision and suitable therapy and care. This process typically may consume long time which consists of numerous clinical visits, sometimes involving many Para clinical tests, as well as the physician's own experiences and insight to predict the event. So, there is a growing effort to find more accurate and faster solutions for prediction. In addition to physicians' efforts, some prediction models were created. Mathematical and statistical methods have been used to develop models for prediction. The most commonly used methods include Bayesian network, logistic regression, and ANN models.

Nowadays, ANN model because of its high efficiency and accuracy is the most popular tool for predicting hence this method have been used in very large amount of decision systems. The present study corroborates that ANNs can be trained from clinical data available for the diagnosis of the disease. ANNs have the ability to learn classification or pattern recognition tasks thus AMI patients are classified into two categories, namely LOHF and non-LOHF from complex data sets. Furthermore, we presented a medical decision support system based on the MLP and RBF neural networks architecture to predict the LOHF for patients who have experienced their first-ever, non-fatal AMI but who had never experienced heart failure and EOHF.

Conclusions

In our study, we presented a medical decision support system based on the MLP and RBF neural network architectures for the LOHF prediction. In particular, we identified 19 input variables critical to LOHF prediction and encoded them accordingly. The system is trained through an improved BP algorithm. A database consisting of 3109 cases was used in this study and 10-fold cross validation was applied to assess the generalization of the models resulting in sensitivity of 87.1% and specificity of 90%, whereas for the RBF network, these values were 94.3% and 84.4%, respectively. The Findings of our study show that the proposed systems can achieve very high diagnostic accuracy and comparably small intervals, proving their efficiency as an alternative and adjunctive option in clinical diagnosis decision of LOHF.

Acknowledgements

The authors would like to thank the School of Population Health at the University of Western Australia for providing us with a complete copy of

MONICA data linked to Mortality and Hospital Morbidity data.

Corresponding Author:

Nader Salari, Ph.D. Candidate at, University Putra Malaysia;
Department of Biology, Faculty of Science, University Putra Malaysia, Serdang, Selangor, Malaysia.
He is a permanent lecturer at the department of biostatistics and epidemiology, School of Public Health, Kermanshah State University of Sciences, Kermanshah, Iran.
nader.salari.1344@gmail.com

References:

1. Nadar, S., Prasad, N., Taylor, R.S., Lip, G.Y.H. Positive pressure ventilation in the management of acute and chronic cardiac failure: a systematic review and meta-analysis. *International journal of cardiology*, 2005. 99(2): p. 171-185.
2. Bordier, P. Sleep apnoea in patients with heart failure. Part I: Diagnosis, definitions, prevalence, pathophysiology and haemodynamic consequences. *Archives of Cardiovascular Diseases*, 2009. 102(8-9): p. 651-661.
3. Cohn, J.N., Ferrari, R., Sharpe, N. Cardiac remodeling--concepts and clinical implications: a consensus paper from an international forum on cardiac remodeling* 1. *Journal of the American College of Cardiology*, 2000. 35(3): p. 569-582.
4. Gheorghide, M., Pang, P.S. Acute Heart Failure Syndromes. *Journal of the American College of Cardiology*, 2009. 53(7): p. 557-573.
5. Barlow, P., Teasdale, G., Jennett, B., Murray, L., Duff, C., Murray, G. Computer-assisted prediction of outcome of severely head-injured patients. *Journal of microcomputer applications*, 1984. 7(3-4): p. 271-277.
6. Fabbri, A., Servadei, F., Marchesini, G., Stein, S., Vandelli, A. Early predictors of unfavourable outcome in subjects with moderate head injury in the emergency department. *Journal of Neurology, Neurosurgery & Psychiatry*, 2008. 79(5): p. 567.
7. Hsu, M.H., Li, Y.C., Chiu, W.T., Yen, J.C. Outcome prediction after moderate and severe head injury using an artificial neural network. *Studies in health technology and informatics*, 2005. 116: p. 241.
8. Lang, E.W., Pitts, L.H., Damron, S.L., Rutledge, R. Outcome after severe head injury: an analysis of prediction based upon comparison of neural network versus logistic regression analysis. *Neurological research*, 1997. 19(3): p. 274.
9. Pang, B.C., Kuralmani, V., Joshi, R., Hongli, Y., Lee, K.K., Ang, B.T., Li, J., Leong, T.Y., Ng, I. Hybrid outcome prediction model for severe

- traumatic brain injury. *Journal of Neurotrauma*, 2007. 24(1): p. 136-146.
10. Smits, M., Dippel, D.W.J., Nederkoorn, P.J., Dekker, H.M., Vos, P.E., Kool, D.R., van Rijssel, D.A., Hofman, P.A.M., Twijnstra, A., Tanghe, H.L.J. Minor Head Injury: CT-based Strategies for Management—A Cost-effectiveness Analysis. *Radiology*, 2010. 254(2): p. 532.
 11. Li, Y.C., Liu, L., Chiu, W.T., Jian, W.S. Neural network modeling for surgical decisions on traumatic brain injury patients. *International journal of medical informatics*, 2000. 57(1): p. 1-9.
 12. Hamner, J.B., Ellison, K.J. Predictors of hospital readmission after discharge in patients with congestive heart failure. *Heart & Lung: The Journal of Acute and Critical Care*, 2005. 34(4): p. 231-239.
 13. Najafi, F., Dobson, A.J., Hobbs, M., Jamrozik, K. Temporal trends in the frequency and longer-term outcome of heart failure complicating myocardial infarction. *European journal of heart failure*, 2007. 9(9): p. 879.
 14. Najafi, F., Dobson, A.J., Hobbs, M., Jamrozik, K. Late-onset heart failure after myocardial infarction: Trends in incidence and survival. *European journal of heart failure*, 2008. 10(8): p. 765.
 15. Eggers, K.M., Ellenius, J., Dellborg, M., Groth, T., Oldgren, J., Swahn, E., Lindahl, B. Artificial neural network algorithms for early diagnosis of acute myocardial infarction and prediction of infarct size in chest pain patients. *International journal of cardiology*, 2007. 114(3): p. 366-374.
 16. Stone, P.H., Raabe, D.S., Jaffe, A.S., Gustafson, N., Muller, J.E., Turi, Z.G., Rutherford, J.D., Poole, W.K., Passamani, E., Willerson, J.T., Sobel, B.E., Robertson, T., Braunwald, E. Prognostic significance of location and type of myocardial infarction: Independent adverse outcome associated with anterior location. *Journal of the American College of Cardiology*, 1988. 11(3): p. 453-463.
 17. Tunstall-Pedoe, H., Kuulasmaa, K., Amouyel, P., Arveiler, D., Rajakangas, A.M., Pajak, A. Myocardial infarction and coronary deaths in the World Health Organization MONICA Project. Registration procedures, event rates, and case-fatality rates in 38 populations from 21 countries in four continents. *Circulation*, 1994. 90(1): p. 583-612.
 18. Holman, C.D.A.J., Bass, A.J., Rouse, I.L., Hobbs, M.S.T. Population based linkage of health records in Western Australia: development of a health services research linked database. *Australian and New Zealand Journal of Public Health*, 1999. 23(5): p. 453-459.
 19. Holman CD, Bass AJ, Rouse IL, Hobbs MS. Population-based linkage of health records in Western Australia: development of a health services research linked database. 1999. 23: p. 453-9.
 20. Gallant, A.R., White, H. On learning the derivatives of an unknown mapping with multilayer feedforward networks. *Neural Networks*, 1992. 5(1): p. 129-138.
 21. Taylor, J. *Neural networks and their applications*. Computers & Mathematics with Applications, 1997. 33(5): p. 131.
 22. Billings, S.A., Zheng, G.L. Radial basis function network configuration using genetic algorithms. *Neural Networks*, 1995. 8(6): p. 877-890.
 23. Pedrycz, W. Conditional fuzzy clustering in the design of radial basis function neural networks. *Neural Networks, IEEE Transactions on*, 1998. 9(4): p. 601-612.
 24. Kubat, M. Decision trees can initialize radial-basis function networks. *Neural Networks, IEEE Transactions on*, 1998. 9(5): p. 813-821.
 25. Moody, J., Darken, C. *Learning with localized receptive fields*. 1988. Morgan Kaufmann.

11/20/2012

A Trail of Using Green Tea for Competing Toxicity of Acrylamide on Liver Function

Thanaa A. El- Kholly*, Nahlaa A. Khalifa, A.K. Alghamidi, and Arwa M. Badereldin

Department of Clinical Nutrition, Faculty of Applied Medical Sciences, King Abdul Aziz University, Jeddah, Saudi Arabia. *telkholy@kau.edu.sa

Abstract: Acrylamide (AA) is neurotoxic to experimental animals and humans. Also, it has mutagenic and carcinogenic effects. This study was carried out to investigate the effects of green tea extract on liver function test in male rats received different doses of acrylamide. Animals were assigned at random to six groups: group 1 served as control, while groups 2, 3 were received 7, 14 mg/100g B.W /day of acrylamide, respectively in drinking water for 15 and 30 days. Group 4 received green tea 1.5% concentration and groups 5, 6 received 7, 14 mg/100 g B.W /day of acrylamide in a combination with green tea for 15 and 30 days. Aspartate aminotransferase (AST), and Alanine aminotransferase (ALT) and Alkaline phosphates (ALP), significantly increased whereas cholinesterase activity declined significantly in rats received AA in both concentrations and time in comparison with the control. However, the values of cholinesterase activity decreased when rats received green tea alone or in combination with AA.

[Thanaa A. El- Kholly, Nahlaa A. Khalifa, A.K. Alghamidi, and Arwa M. Badereldin. **A Trail of Using Green Tea for Competing Toxicity of Acrylamide on Liver Function.** *Life Sci J* 2012;9(4):3690-3695]. (ISSN: 1097-8135). <http://www.lifesciencesite.com>. 547

Key words: Acrylamide – Cholinesterase- Aspartate aminotransferase (AST) - Alanine aminotransferase (ALT) - alkaline phosphates (ALP) - Green tea.

1. Introduction

Acrylamide (AA) (2-propenamide) is an industrial chemical used for the production of polymers which are used as flocculants for purification of drinking and waste water, thickeners for agricultural sprays, gel chromatography and electrophoresis, soil stabilizers and in the paper and pulp industry. Acrylamide monomer may form in certain foods cooked at high temperatures)¹. The highest concentrations of Acrylamide have been identified in potato and grain-base foods that are cooked at very high temperatures (e.g. frying, grilling or baking)². Acrylamide is thought to form in food principally from the interaction of amino acid asparagines with glucose or other carbohydrates³. Acrylamide have significant binding capacity to liver, kidney, brain and erythrocyte⁴. Acrylamide has been classified as a group 2A carcinogen by the international Agency for Research on Cancer⁵.

Several mechanisms have been suggested to explain Acrylamide induce its toxic effect. It is metabolized into glycidamide via the cytochrome P450 (CYP450) pathway to produce glycidamide (2E1), forming a DNA- reactive epoxide.⁶ Reactive with enzymes or receptors may induce changes in cellular functions and signal pathways, leading to carcinogenesis.⁷ changes in dopamine receptor affinity and alterations of thyroid stimulating hormones, prolactin, and testosterone levels. This observed in rats following AA treatment.⁸ Oxidative stress is considered as one of the important mechanisms of toxic effects of Acrylamide. AA causes oxidative damage through inducing the

generation of reactive oxygen species (ROS) which enhanced the production of lipid peroxidase reducing the antioxidant defense systems⁹.

Antioxidants are chemicals that reduce oxidative damage to cells and biochemical's. Some dietary antioxidants vitamins A, C, and E can be considered as protective agents against genotoxic action of Acrylamide¹⁰. Green tea getting so much attention from the science world because of the antioxidant Epigallocatechin-3 gallate (EGCG) that is the most abundant catechin preserved in green tea¹¹. Green tea is characterized by a high content of flavonoids. Flavonoids are large group of phenolic products of plant metabolism (strong antioxidant)¹².

The present study was carried out to investigate the effects of using green tea for coping toxicity of acrylamide on liver function.

2. Materials and Methods

Materials

Green tea

Green tea was provided by local market. It was prepared freshly and adds twice as the sole source of drinking water for rat at concentration 1.5%¹³.

Acrylamide (99.9% purity) was purchased from Sigma chemical Co. It used in two different concentrations 7 and 14 mg/100 g B.W.¹⁴.

Animals:

Sixty mature (2-4 months) male albino rats weighing from 120±10 g body weight were used in this study.

Animal ration:

Normal ration for rats given to control group. The rats were fed balanced rations and free access water was allowed.

Methods**Experimental design**

Six equal groups each of ten rats were subjected to dosing. The first group (G1) of rats kept as a control. The second (G2) and third groups (G3) of rats were received 7, 14 mg/100g B.W. /day of acrylamide, in drinking water for 15 and 30 days. While the fourth (G4) group rats received green tea 1.5% as sole source of water from day 1 to day 30, the fifth (G5) and sixth (G6) groups received with 7, 14 mg/100g B.W/day acrylamide respectively for 15 and 30 days and green tea 1.5% from the first day to day 30.

Blood Sampling

Five blood samples were collected from rats from each group from eye plexus at 15 and 30 days in clean dry sterile and labeled centrifuge tubes. Separating serum was done by centrifugation at 3000 r.p.m for 10 minute.

Animal Ration analysis

Analytical measurements include; Determination of crude protein content by AOAC (1995)¹⁵ and crud fiber percentage according to Less, (1975)¹⁶ Determination of fat, Ash and moisture content by either extraction as described by Horwitz (1980)¹⁷ Aflatoxin content¹⁸ and determination of acid number in fat¹⁹.

Preparation of green tea extract²⁰.

15 g of green tea powder were soaked in 1 liter of boiling distilled water for 5 minutes and filtered to make 1.5 % green tea solution. Green tea extracted (GTE), was provided to rats as their sole source of drinking water.

Biochemical Analysis

Serum samples were subjected to quantities determination of Serum Aspartate amino transferase (AST) and Serum Alanine amino transferase (ALT), according to Retman, (1975),²¹ Serum Alkaline phosphates (ALP), according to Roy,(1970)²² Serum Cholinesterase activities according to Tietz, (1986).²³

Statistical Analysis was carried out by Snedecor Snedecor, (1995).²⁴

3. Results**Aspartate aminotransferase (AST)**

Statistical analysis of data represent in **Table 1**. Shows that AA elicited significant increase of Aspartate aminotransferase (AST) at the two doses (7, 14 mg/100g B.W. /day) G2 & G3 respectively for 15 days with the mean values of 48.54 ± 3.38 ($P < 0.01$) and 55.46 ± 3.61 ($P < 0.001$) respectively compared with non- treated (control) rats G1 with the mean values of 29.33 ± 2.82 . There was slightly significant increase at the two previous doses after 30 days with the mean values of 41.25 ± 2.90 ($P < 0.05$) & 48.00 ± 3.11 ($P < 0.01$) compared with non-treated rats with the mean value 30.67 ± 2.29 .

Rats received green tea extract only (antioxidant) group 4 had no effect on enzyme activities after 15 & 30 days. The mean values were 28.66 ± 1.41 & 29.67 ± 2.77 compared to non- treated (control) rats (29.33 ± 2.82 & 30.67 ± 2.29), respectively. This indicated that green tea (antioxidant) had activities of such enzymes but was less than that received Acrylamide. Group 5 which received green tea extract (1.5%) with 7 mg/100g B.W/day Acrylamide for 15 and 30 days showed good effect in decreasing the effect of Acrylamide on damaging cell with mean values 37.23 ± 2.96 & 33.76 ± 3.43 respectively. The rats in group 6 given green tea extract (1.5%) with 14 mg/100g B.W/day Acrylamide respectively for 15 and 30 days also showed good effect in decreasing the effect of Acrylamide on damaging cell with mean values of 42.67 ± 3.21 ($P < 0.05$) & 39.78 ± 3.01 ($P < 0.05$) respectively.

Table 1. Effect of green tea extract on Aspartate Aminotransferase (AST) in rats orally administrated Acrylamide (7 and 14 mg/100g B.W./days for 15&30 day) n=5

Studied groups	AST u / l	
	15 days	30 days
G1	29.33 ± 2.82	30.67 ± 2.29
G2	48.54 ± 3.38 ***	41.25 ± 2.90 *
G3	55.46 ± 3.61 ***	48.00 ± 3.11 **
G4	28.66 ± 1.41	29.67 ± 2.77
G5	37.23 ± 2.96	33.76 ± 3.43
G6	42.67 ± 3.21 *	39.78 ± 3.01 *

N=Number of rats; * Significant at $P < 0.05$; **Significant at $P < 0.01$; *** Significant at $P < 0.001$

Alanine aminotransferase (ALT)

Statistical analysis of data represent in **Table 2**. Shows that AA elicited significant increase of Alanine aminotransferase (ALT) at the two doses (7, 14 mg/100g B.W. /day) G2 & G3 respectively for 15 days with the mean values of 23.90 ± 3.34 ($P < 0.01$) and 41.10 ± 2.85 ($P < 0.001$) respectively compared with non- treated (control) G1 rats with the mean values of 17.71 ± 2.39 . There was slightly significant increase at the two previous doses after 30 days with

the mean values of 27.11 ± 2.17 ($P < 0.05$) & 30.06 ± 2.59 compared with non- treated rats with the mean value 18.00 ± 2.01 .

Rats received green tea extract alone (antioxidant) group 4 had no effect on enzyme activities after 15 & 30 days. The mean values were 16.23 ± 2.01 & 18.50 ± 2.59 U/L compared to non-treated (control) rats (17.71 ± 2.39 & 18.00 ± 2.01 U/L), respectively. This indicated that green tea (antioxidant) had activities of such enzymes but was less than that received Acrylamide. Group 5 rats which received green tea extract (1.5%) with 7 mg/100g B.W/day Acrylamide for 15 and 30 days showed good effect in decreasing the effect of Acrylamide on damaging cell with mean values 27.20 ± 3.20 & 23.48 ± 1.93 respectively. The rats of group 6 given green tea extract (1.5%) with 14 mg/100g B.W/day Acrylamide respectively for 15 and 30 days also showed good effect in decreasing the effect of Acrylamide on damaging cell with mean values of 32.66 ± 4.11 ($P < 0.05$) & 26.01 ± 2.22 ($P < 0.05$) respectively.

Table 2. Effect of green tea extract on Alanine Aminotransferase (ALT) in rats orally administrated Acrylamide (7 and 14 mg/100g B.W./days for 15&30 day) n=5

Studied groups	ALT U/L	
	15 days	30 days
G1	17.71 ± 2.39	18.00 ± 2.01
G2	23.90 ± 3.34 **	27.11 ± 2.17 *
G3	41.10 ± 2.85 ***	30.06 ± 2.59 **
G4	16.23 ± 2.01	18.50 ± 2.59
G5	27.20 ± 3.20	23.48 ± 1.93
G6	32.66 ± 4.11 *	26.01 ± 2.22 *

N=Number of rats; * Significant at $P < 0.05$; **Significant at $P < 0.01$; *** Significant at $P < 0.001$

Alkaline phosphatase (ALP)

Statistical analysis of data represent in **Table 3**, shows that AA elicited significant increase of alkaline phosphatase (ALP) at the two doses (7, 14 mg/100g B.W. /day) (group2 & group3) for 15 days with the mean values of 178.96 ± 4.10 U/L ($P < 0.05$) and 181.22 ± 3.93 ($P < 0.001$) respectively compared with non- treated (control) rats (group 1) with the mean values of 160.56 ± 4.07 . There was significant increase at the two previous doses after 30 days with the mean values of 185.33 ± 4.09 ($P < 0.05$) & 198.86 ± 4.81 ($P < 0.01$) compared with non- treated rats with the mean value 168.31 ± 4.11 .

Rats received green tea extract only (antioxidant) G 4 had no effect on enzyme activities after 15 & 30 days. The mean values were 158.73 ± 3.24 & 159.89 ± 4.33 compared to non-treated (control) rats (160.56 ± 4.07 & 168.31 ± 4.11), respectively. This indicated that green tea had

activities of such enzymes but was less than that received Acrylamide. Group five rats which received green tea extract (1.5%) with 7 mg/100g B.W/day acrylamide for 15 and 30 days showed good effect in decreasing the effect of acrylamide on damaging cell with mean values 171.11 ± 3.91 & 169.94 ± 4.39 respectively. The rats of group six given green tea extract (1.5%) with 14 mg/100g B.W/day Acrylamide respectively for 15 and 30 days also showed good effect in decreasing the effect of Acrylamide on damaging cell with mean values of 176.12 ± 4.08 & 179.73 ± 3.49 respectively.

Table 3: Effect of green tea extract on Alkaline phosphates (ALP) in rats orally administrated Acrylamide (7 and 14 mg/100g B.W./day for 15&30 days) n=5

Studied groups	ALP U/L	
	15 days	30 days
G1	160.56 ± 4.07	168.31 ± 4.11
G2	178.96 ± 4.10 *	185.33 ± 4.09 *
G3	181.22 ± 3.93 **	198.86 ± 4.81 **
G4	158.73 ± 3.24	159.89 ± 4.33
G5	171.11 ± 3.91	169.94 ± 4.39
G6	176.12 ± 4.08	179.73 ± 3.49

N=Number of rats; * Significant at $P < 0.05$; **Significant at $P < 0.01$; *** Significant at $P < 0.001$

Cholinesterase activity

Statistical analysis of data represent in **Table 4**, showed that Cholinesterase activity declined significantly in rats received acrylamide in both concentrations and time (7, 14 mg/100g B.W. /day for 15&30 days) G2 & G3 with the mean values 492.84 ± 28.17 ($P < 0.01$), 340.65 ± 21.33 ($P < 0.001$), 540.69 ± 24.97 ($P < 0.05$) and 498.31 ± 26.82 , ($P < 0.01$) respectively in comparison with the non treated control rat G1 (631.20 ± 26.01 & 622.55 ± 23.76). However, the values of cholinesterase activity showed continuous decrease when rats treated with green tea alone G4 with the mean values 581.11 ± 22.60 & 518.65 ± 29.13 ($P < 0.05$) or in combination with acrylamide with the mean values 408.67 ± 22.49 ($P < 0.001$), 500.38 ± 22.56 ($P < 0.01$), 321.25 ± 21.91 ($P < 0.01$), and 453.98 ± 27.43 ($P < 0.001$) G5 & G6 respectively.

Rats received green tea extract (antioxidant) only, (group 4), had no effect on enzyme activities after 15 days with the mean values of 581.11 ± 22.60 & but had a significant effect after 30 days by 518.65 ± 29.13 ($P < 0.05$) compared to non- treated (control) rats (631.20 ± 26.01 & 622.55 ± 23.76), respectively. Group 5 which received green tea extract (1.5%) with 7 mg/100g B.W/day Acrylamide for 15 and 30 days showed a highly significant effect in decreasing the effect of Acrylamide on damaging cell with mean 408.67 ± 22.49 ($P < 0.001$) & $500.38 \pm$

22.56 ($P<0.01$) respectively. The rats of group 6 given green tea extract (1.5%) with 14 mg/100g B.W/day Acrylamide respectively for 15 and 30 days also showed highly significant effect in decreasing the effect of Acrylamide on damaging cell with mean values of 321.25 ± 21.91 ($P<0.01$) & 453.98 ± 27.43 ($P<0.001$) respectively.

Table 4. Effect of green tea extract on cholinesterase activity in rats orally administrated Acrylamide (7 and 14 mg/100g B.W. /day for 15&30 day) n=5

Studied groups	Cholinesterase U / L	
	15 days	30 days
G1	631.20±26.01	622.55± 23.76
G2	492.84±28.17 **	540.69±24.97 *
G3	340.65±21.33 ***	498.31±26.82 **
G4	581.11±22.60	518.65±29.13 *
G5	408.67±22.49 ***	500.38± 22.56 **
G6	321.25±21.91 **	453.98±27.43 ***

N=Number of rats; * Significant at $P < 0.05$; **Significant at $P < 0.01$; *** Significant at $P < 0.001$

4. Discussion

Acrylamide (AA) can be formed in certain foods by heating, predominantly from the precursor asparagines. It is a carcinogen in animal experiments. Acrylamide was tested for carcinogenicity in one experiment in rats by oral administration. Acrylamide have significant binding capacity to liver^{4; 6; 25; 26; 27; 28; 29}

The liver performs numerous functions that include but not limited to lipid, carbohydrate and protein metabolism. The liver also has immune logic activity, contributes to digestion, and is essential for detoxification of many endogenous and exogenous compounds.³⁰ In regard to the effect of used acrylamide on serum liver enzyme activity; our data revealed that treated groups displayed significant increase in (AST, ALT and ALP) at the two doses and slightly increase after 30 days. These results agree with Yousef. and El-Demerdash, (2006)³¹. Liver revealed congestion sinusoids with fatty degeneration and necrosis after administration a lethal dose of acrylamide to monkey was reported by Mccollister, (1964)³² AA had a significant capacity to liver Glutathione (reduce GSH)³³. In addition, it induced cellular transformation and increase in the degree of membrane permeability of liver³⁴. The disruption of these membranes may cause the translocation of liver enzyme ALT and AST into the blood, as observed in this study.

Green tea (*Camellia sinensis*) contains high level of polyphenols including catechin, epicatechin, gallic acid, epigallocatechin, epicatechin gallate, and gallic acid gallate^{32; 33}. Polyphenols from green tea are efficient free radical and singlet oxygen scavengers^{34; 35} and green tea extract (GTE) inhibits

lipid peroxidation in vitro systems, in experimental animals, and in humans^{32, 33, 34;34; 35}.

Rats received green tea extract alone (antioxidant) in group 4 had no effect on enzyme activities. While the rats in Group 5 which received green tea extract (1.5%) with 7 mg/100g B.W/day Acrylamide for 15 and 30 days, showed a highly significant effect in decreasing the effect of Acrylamide on damaging cell. This result agreed with the study of Higdon JV, and Frei B (2003)³⁶ which revealed that green tea polyphenols, particularly EGCG(-)epigallocatechin gallate are naturally occurring strong antioxidants. Tea catechins and polyphenols are effective scavengers of reactive oxygen species in vitro and may also function indirectly as antioxidants through their effects on transcription factors and enzyme activities. The fact that catechins are rapidly and extensively metabolized emphasizes the importance of demonstrating their antioxidant activity in vivo. In humans, modest transient increases in plasma antioxidant capacity have been demonstrated following the consumption of tea and green tea catechins. The effects of tea and green tea catechins on biomarkers of oxidative stress, especially oxidative DNA damage, appear very promising in animal models, but data on biomarkers of in vivo oxidative stress in humans are limited.

A recent study showed that the addition of EGCG and other green tea constituents to tissue culture medium generated high levels of hydrogen peroxide (H_2O_2) and it was postulated that this might represent an artefact of cell culture³⁷. Another study showed similar results, although discriminating between different EGCG concentrations, while the presence of cells decreased H_2O_2 concentrations³⁸.

The co-administration of acrylamide together with green tea reduces the effect of acrylamide on the hepatological markers in serum AST&ALT and ALP^{39; 40; 41}. Green tea enhanced antioxidative abilities in liver and protects liver cells and liver cell membrane against acrylamide action. Bu-Abbas, et al (1945) and Ostrwsk (2004)^{35 and 42} showed that green tea reduce the morphological and biochemical alterations induced by hepatic toxicity agents.

Effect of Acrylamide on Cholinesterase and enzyme found in blood serum is synthesis by liver, hydrolyzes acetylcholine. Acetylcholine is a compound synthesized at the nerve endings, which acts in transmitting impulses from nerve to muscles fiber⁴³. Acrylamide is well-known neurotoxic compound that produces central and peripheral distal axonopathy⁴⁴. In the present study, there is a significant decrease in serum cholinesterase concentrations in group 2 and 3 after 15 and 30 days post high dose feeding Acrylamide as compared with

control (Table 4). Regarding the effect of acrylamide on Cholinesterase activity, our results agreed with that recorded by Tietz, (1996); Khanna, (1992) and Shell, (1992)^{43; 45; 46}. Cholinesterase levels inhibition are indicator for possible neurotoxic effect of organic compound (acrylamide)⁴⁷.

Also decrease in concentration of cholinesterase well appear by⁴⁸ they investigate the neurological defect (skeletal muscles weakness) associated with acrylamide intoxication are mediated by impaired neuro – transmission at central and peripheral synapses (decrease in Acetylcholine). Administrated of green tea extrat alone or in combination with AA significantly inhibited cholinesterase levels on the same table Okello *et al.*, 2004⁴⁹ finding suggest that tea infusion contain biologically active principally, perhaps acting synergistically that may be due to the inhibition of acetyl cholinesterase and butyric cholinesterase

Conclusion

Supplementation of rats with antioxidant (green tea) reduces the effect of AA on the hepatogical markers in serum AST & ALT and ALP. Also green tea enhanced antioxidative abilities in liver and protects liver cells membrane against AA action.

Corresponding author

Thanaa A. El- Kholy
Department of Clinical Nutrition, Faculty of Applied Medical Sciences, king Abdul Aziz University, Jeddah, Saudi Arabia
telkholy@kau.edu.sa

References

1. Surdyk, N.; Rosen, J.; Andersson, R., CC. and Aman, P., (2004): Effect of asparagines fructose, and backing conditions on acrylamide cotent in yeast – leavened wheat bread. *Journal of Agriculture and food Chemistry*; 52:2047-2051.
2. Tareke, E.; Rydberg, P. and Karlsson, P. (2002): Analysis of acrylamide, a carcinogen formed in heated foodstuffs. *J.Agric. Food Chem.*, 50:4998-5006.
3. Taubert, D.; Harlfinger, S.; Henkes, L., Berkels, R., and Schomig, E. (2004): Influence of processing parameters on acrylamide formation during frying of potatoes. *Journal of Agricultural and food Chemistry*, 52: 2735.
4. Sumner S. C., Selvaraj, L.; Nauhaus, S.K. and Fennell, T. R. (1997): Urinary metabolites from F344 rats and B6c3F1 mice co administered acrylamide and acrylonitrile for 1 or 5 days, *Chem. Res. Toxicol.*, 10: 1152-1160.
5. (IARC) International Agency for Research on cancer (1994). *Monographs on the Evaluation of Carcinogenic Risks to Humans: Some Industrial Chemicals No. 60*. IARC, Lyon, France.
6. Calleman, C J.; Bergmark, E. and Costa, L. (1990):

Acrylamide is metabolized to glycidamide in the rat: evidence from hemoglobin adducts formation *Chem. Res Toxicol.*, (5): 406-12.

7. Johnson, K.A.; Gorzinski, K. M.; Bodner, R.A.; Campbell, C.H.; Wolf, M.A.; Friedman, R.W. and Mast, (1986): Chronic toxicity and Carcinogenicity study on acrylamide incorporated linking water of Fischer 344 rats, *Toxicol. Appl.Pharmacol.*, 85:164.
8. Ali, S.F.; Hong, J.S., W.E.; Uphouse, L.L. and Bondy, S. C. (1983): Effect of acrylamide on neurotransmitter metabolism and neuropeptide levels in several brain regions and upon circulating hormones. *Arch. Toxicol.*, 52: 35-43.
9. Dobrzynska, I.; Sniecinska, A.; Skrzydlewska, E. and Figaszewski Z.(2004): Green tea modulation of the biochemical and electric properties of rat liver cells that were affected by ethanol and aging. *Cell Mol Biol Lett.*, 9 (4A):709-21.
10. Blasiak J.; Ewa G. Katarzyna, W. and Agnieszka, C. (2004): Genotoxicity of acrylamide in human lymphocytes. *Chemico- Biological Interactions*, 149:137-149.
11. Graham, H.N. (1992): Green tea composition, consumption, and polyphenol chemistry. *Prev. Med.* 21: 334-350. - GMA; Grocery Manufacturers Association (2008): *Acrelamide factors.org/ contact- Us.aspx*.
12. Schmdit, M.; Schmitz, H.J.; Baumgart, A; Guedon, D.; Netsch, M.L.; Kreuter, M.H.; Schmidlin, C.B., and Schrenk, D., (2005): Toxicity of green tea extracts and their constituents in rat hepatocytes in primary culture. *Food and Chemical Toxicology*; Vol.43 Issue (2)307-314 [8 page(s)].
13. Mohamdin, AM.; El-Beshbishy, HA. And EL-Mahdy, MA. (2005): Green tea attenuates cyclosporine A – induced extract oxidative stress in rats. *Pharmacol Res.*, 51 (1):51-7.
14. Jefferty, S.; Lafferty, M.; Kamendulis, Ju; Lee K.; Jiazhong J.E. and Klaunig, J. (2004): Subchronic acrylamide treatment induces a tissue- specific increase in DNA synthesis in the rat *Toxicology Letters*, 154:95-103.
15. AOAC (1995): *Association of official agricultural chemist*, 16ed.P.936. 16. Washington USA.
16. Less, R. (1975): *Aflatoxin Determination and other T.L.C. examination*. Food analysis, 3rd Published by Leonard, H.U.Books, and P.So.P.
17. Horwitz, W. (1980): *Official methods of analysis*. (13th edition) Benjamin Prauklin St., Washington D.C
18. Nabney, J. and Nesbitt, B.F. (1965): spectrophotometric method for determining the aflatoxins. *Analyst* 90:155-160.
19. Koch, F.C and Martin, B.H (1923): *Practical methods in biochemistry* 6th edition. The Williams and Wilkins company, Baltimore .U.S.A.
20. Maity, S.; Vadasirromoni, J.; and Ganguy, D.K. (1998). Role of glutathione in antinuclear effect of hot water extract of black tea. *Jpr.J. Pharmacol.*, 78: 285-92
21. Retman, S. and Fraankel, S. (1957): A calorimetric methods for determination of serum Protein and ferritin by free and attached ribosomes of rat liver. *J. Biol. Chem.*, 244:4308.
22. Roy, A. V. (1970): Rapid methods for alkaline

- phosphates estimation. Clin Chem., 16:431.
23. Tietz, N.W. (1986): Fundamentals of clinical chemistry Edited by N. W., Tietz, Saunders Company, 3rd Ed., Vol. Philadelphia, USA.
 24. Snedecor, C.w. (1969): Statistical methods. 4th Ed., The Iowa state college press, Ames, Iowa.
 25. Dixit, R., Mukhtar, H and Seth, PK.(1980).Binding of acrylamide with Coagulation – S transferases. Chem Biol Internact., 3 : 353 - 359
 26. Dixit, R., Mukhtar, H and Seth, PK. (1981c): Coagulation of Acrylamide with glutathione catalyzed by glutathione-S- transferases of rat liver and brain .Biochem, 130(13);1739-44.
 27. Dixit R.; Seth, PK. And Mukhtar H. (1982): Metabolism of acrylamide into urinary mercapturic acid and cyseine conjugates in rats. Drug Metab Dispos, 10 (2): 196 -197.
 28. Miller, MJ; Carter, DE. And Spices, IG (1982): Pharmacokinetics of acrylamide in Fisher -334 rats. Toxicology and Applied Pharmacology, 63: 36 – 44.
 29. Sumner, S.C.J.; Mac. Neela, J.P. and Fennell, T.R.(1992): Characterization and quantitation of urinary metabolites of (1,2,3C13) Acrylamide in rats and mice using 13C nuclear magnetic resonance spectroscopy. Chem. Res. Toxicol., 5: 81-89.
 30. Susan,E. and May A(1998): The Merck Veterinary manual 8th E.,Nutritional Pupliching, Inc.,Philodelphia, Pennsylvania .
 31. Yousef. M.I., and El-Demerdash, F.M (2006): Acrylamide- induced oxidative stress and biochemical perturbations in rats, Toxicology, 219:133-141.
 32. Mccollister, DD; Oyen F and Rowe V K. (1964.) Toxicology of acrylamide. Toxicol App pharmacol., 6:172-181.
 33. Park, J. L. Kamendulis, M.Friedman, M.A. and Klaunig, J.E. (2002): Acrylamide- induced cellular transformation, Toxicol.Sci. 65:177-183.
 34. Awad, M.E., Abdel-Rahman, M.S., and Hassan, S.A., (1998): Acrylamide toxicity in isolated rat hepatocytes. Toxicol. In Vitro, 12: 699-704.
 35. Bu-Abbas, A., Clifford, M.N., Ioannides, C. and Walker, R. (1995): Stimulation of rat hepatic UDP-glucuronosyl transferase activity following treatment with green tea. Food Chem.Toxicol., 33:27-30.Tietz, 1996.
 36. Higdon JV, and Frei B (2003): Tea catechins and polyphenols: health effects, metabolism, and antioxidant functions. Crit Rev Food Sci Nutr.;43(1):89-143.
 37. Long LH, Clement MV, Halliwell B (2000): Artifacts in cell culture: rapid generation of hydrogen peroxide on addition of (-)-epigallocatechin, (-)-epigallocatechin gallate, (+)-catechin, and quercetin to commonly used cell culture media. Biochem Biophys Res Commun., 273:50-53.
 38. Dashwood WM, Orner GA, Dashwood RH (2002): Inhibition of beta-catenin/Tcf activity by white tea, green tea, and epigallocatechin-3-gallate (EGCG): minor contribution of H(2)O(2) at physiologically relevant EGCG concentrations. Biochem Biophys Res Commun., 296:584-8.
 39. Hasegawa, R; Chujo, T.; Sai-Kato, K.; Umemura, T.; Tanimura, A. and Kurokawa,Y.(1995): Preventive effects of green tea against liver oxidative DNA damage and hepatotoxicity in rats treated with 2-nitropropane. Food Chem.Toxicol. 33:961 -970.
 40. Imai, K., and Nakachi (1995): cross sectional study of effects of drinking green tea on cardiovascular and liver diseases.KBMJ; 310:693-696.
 41. Sai, K.; Kai, S.; Umemura, T.; Tanimura, A.; Hasegawa, R.; Inoue,T. and Kurokawa,Y.(1998): Protective effects of green tea on hepatotoxicity , oxidative DNA damage and cell proliferation in the rat liver induced by repeated oral administration of 2- nitropropane. Food Chem. Toxicol., 36:1043 – 1051.
 42. Ostrwsk J.; Luczaj, W.; Kasackka, I.; Rozanski, A.and Skrzydlewska, E. (2004): Green tea protects against ethanol – induced lipid peroxydation in rat organs. Alcohol., 32:25-32
 43. Tietz, N.W. (1996): Fundamentals of clinical chemistry 4thEd., Vol 1, (Moss, D. W and Hendersson, A. R.) W. B Saunders company, Philadelphia USA.
 44. Costa, L.G (1996): Biomarker Research in Neurotoxicology: The Role of Mechanistic studies to Bridge the Gap between the Laboratory & Epidemiology Investigations Environmental Health Perspectives 104.
 45. Khanna, V. K. Husain, R. and Seth, R.K.(1992): Protein malnourishment a predisposing factor in acrylamide toxicity in pregnant rats . J. toxicol. Environ-Health, 36: 293 -305.
 46. Shell, L.; Rozum,M.; Jortner,B. and Ehrich,M(1992): Neurotoxicity of acrylamide and 2,5 – hexanedione in rats evaluated using afunction abservational battery and pathological examination. Neurotoxicol Tertol., Vol 14: 273 – 83.
 47. Lola R.; Antonia L.; Francisco L. and Fernando S. (2005): Chronic Neuropsychological Sequae of Cholinesterase inhibitors in the absence of structural brain damage: two Cases of acute poisoning. Environ-Health Perspective, 113(6): 762-766.
 48. Barber, D.s., and Lopachin, R.M. (2004): Proteomic analysis of acrylamide protein adducts formation in rate brain synaptosomes. Toxicol. Appl. Pharmacol., 201120 – 36.
 49. Okello, E.J; Sareleve, SU. And Perry E.K.(2004): *In vitro* anti- beta secreatease and dual anticholinestrse activity of camellia sinesis L.(lea) relevant of treatment.J. of phylotherapy Res., 18: 624 – 627.

11/20/2012