

# CONTENTS

259	<b>The Mechanism of 2,4-Dichlorophenoxyacetic Acid Neurotoxicity on Rat Brain Tissue by Using FTIR Spectroscopy</b> Gehan A. Raouf, Safaa Y. Qusti, Awatef M. Ali. and Tahani H. Dakhakhni	1686-1697
260	<b>Noun Phrases in Vafs Dialect</b> Fatemeh Moosavi mirak, Nasrin Safavizadeh	1698-1703
261	<b>Study of Cognitive Functions and Cerebral Blood Flow in Elderly</b> Afaf A. Hemedat, Dalia R. Abdel-Rahman, Mohamed Naguib Abdalla, Ahmed A. El-Naggar and Dina M. Riad	1704-1707
262	<b>An Examination on the Effect of the Performance Audit Implementation on the Improvement of the Productivity of Public Sector Management Systems in Iran (A Case Study in Supreme Audit Court)</b> Sirous Fattahi, Dr. Seyed Ali Vaez , Dr . Ali Hossein Hosseinzadeh	1708-1724
263	<b>Improved shoot organogenesis of <i>Echinacea angustifolia</i> DC treated with ethylene inhibitors</b> Soo Cheon Chae, and Sang Un Park	1725-1728
264	<b>Ab initio study of thermodynamic properties, IR spectra and electrical properties of <math>Cu_4O_3H_2</math> nanosemiconductor</b> Elham Pournamdari , Majid Monajjemian and Karim Zare	1729-1738
265	<b>Analysis of Totemic Cow and its Association with the Fereydoun Family in Ferdowsi's Shahnameh</b> Masoumeh Zandieh, Kheironnesa Mohammadpour and Nahid Sharifi	1739-1747
266	<b>The Comparison of Stressors in the Assessment of Basic Clinical Skills with Traditional Method and OSCE in nursing Students</b> Maryam Bagheri, Malihe Sadeghnezhad Forotgheh , Maryam Shaghayee Fallah	1748-1752
267	<b>Anthropometric assessment in children under 2 year in Torosk, a rural area of Sabzevar, Iran 2004-6</b> Akaberi Arash, Hashemian Masoumeh , Assarroudi Abdolghader, <u>Hasanpour Kazem</u>	1753-1758
268	<b>A New Algorithm for Detecting the Correctness of Merging Operation in Workflow</b> Hodayun Motameni, Somayeh gilani, Fatemeh Zahra naderi and Behnam Barzegar	1759-1768
269	<b>Analysis of hydraulic fracturing length and aperture on the production rate in fractured reservoir</b> Jaber Taheri Shakib, Abdolvahed Ghaderi and Abbas Abbaszadeh Shahri	1769-1777
270	<b>Assessment of relationship between Iron deficiency and preterm labor</b> Nazli Navali	1778-1781
271	<b>A simple model to compute the blood flows through obstructed blood vessels</b> Mohsen Gh Kharaji, Fakhroddin Dadjoo, Y Alirezaei, Ali Falavand, Ameneh Langari	1782-1788
272	<b>Study of the health threatening mercury effective parameters for its removal from the</b>	1789-1791

**aqueous solutions by using activated carbons**

Maryam K. Hafshejani, Farzaneh Khandani, Ramin Heidarpour, Amin Sedighpour, Hamzeh Fuladvand, Roohollah Shokuhifard, Armin Arad

- 273 Assessment of Different Surface Treatments Effect on Surface Roughness of Zirconia and Its Shear Bond Strength to Human Dentin** 1792-1803  
Manal R. Abu-Eittah
- 274 Time-dependent two-dimensional Zakharov-Kuznetsov equation in the electron-positron-ion plasmas** 1804-1813  
Ali H. Bhrawy A.S. Alofi and A.M. Abdelkawy
- 275 Effect of some agricultural treatments on *Beta vulgaris* L. cv. Pleno root** 1814-1819  
Sakr, M. M., O. A. Almaghrabi and S. M. H. Gowayed
- 276 Effective Social factors on Organizational Learning** 1820-1826  
Davood Gharakhani, Amid Pourghafar Maghferati, Mehrdad Tavakolirad
- 277 Derivation of a single reservoir operation rule curve using Genetic Algorithm** 1827-1830  
Haghiabi Amirhamzeh
- 278 The study of the effect of liquidity management on return on assets and return on rights of the share holders of the firms listed on Tehran stock exchange.** 1831-1835  
Alireza Zamanpour, Shahroch Bozorgmehrian
- 279 Results of Multilevel Anterior Cervical Discectomy and Cage Assisted Fusion without Plates** 1836-1845  
Omar Kelany, Ahmed Hashem Amin and Mohamed Gamal

## The Mechanism of 2,4-Dichlorophenoxyacetic Acid Neurotoxicity on Rat Brain Tissue by Using FTIR Spectroscopy

Gehan A. Raouf<sup>1\*</sup>, Safaa Y. Qusti<sup>2</sup>, Awatef M. Ali.<sup>3</sup> and Tahani H. Dakhakhni<sup>4</sup>

<sup>1</sup> Medical Biophysics Lab., King Fahd Medical Research Centre; Biochemistry Dept., King Abdulaziz University, 21551 Jeddah –KSA B.O.Box:42805, Spectroscopy Dep. Physics Div.-National Research, Cairo- Egypt.

<sup>2,4</sup>Biochemistry Dept., Faculty of Science, King Abdulaziz University, Jeddah –KSA

<sup>3</sup>Zoology Dept., Faculty of Science, Alexandria University-Egypt.

[gehan\\_raouf@hotmail.com](mailto:gehan_raouf@hotmail.com) - [jahmed@kau.edu.sa](mailto:jahmed@kau.edu.sa)

**Abstract:** Previous studies demonstrated that the herbicide 2,4-dichlorophenoxyacetic acid (2,4-D), toxicity may be due to cell death by apoptosis. 2,4-D is approved to be associated with many disorders especially neurotoxicity. FTIR spectroscopy and transmission electron microscopy were used to investigate the neurotoxicity induced by LD<sub>50</sub> dose of 2,4-D onto the cerebellum rat brain tissue. In response to 2,4-D stress, there is a significant increase in the intensities as well as bands area of 3463cm<sup>-1</sup>, 3276cm<sup>-1</sup> and 3165cm<sup>-1</sup> bands; the first band corresponds to the changes in the number of lipids hydroperoxyl and to lipid hydroxyl groups formed by oxidation. There are decrease in membrane lipid polarity, increase the disorder and the looseness of lipid chain packing and a significant increase in the formation of carbonyl compounds. Moreover, protein content and secondary structure were significantly influenced upon 2,4-D intoxication. Consistent with the IR results, EM analysis revealed morphological changes in the 2,4-D treated cerebellum tissue including nuclear damage with massive condensation of chromatin, mitochondrial matrix swelling, loss of cristae and rough endoplasmic reticulum dilatation and vesiculation. Thus, 2,4-D influences membrane lipid polarity, fluidity and protein order, in addition to the morphological changes all of which can be considered as apoptosis biomarkers.

[Gehan A. Raouf, Safaa Y. Qusti, Awatef M. Ali. and Tahani H. Dakhakhni. **The Mechanism of 2,4-Dichlorophenoxyacetic Acid Neurotoxicity on Rat Brain Tissue by Using FTIR Spectroscopy** *Life Sci J* 2012;9(4):1686-1697] (ISSN:1097-8135). <http://www.lifesciencesite.com>. 259

**Key words:** Fourier transform infrared spectroscopy (FTIR), Neurotoxicity, Apoptosis, 2,4-Dichlorophenoxyacetic acid (2,4-D), Transmission Electron Microscope (TEM).

### 1. Introduction

Since the early 1990s, it has been argued that many chemicals used for agricultural, industrial or domestic purposes can enter the food chain, and produce a number of disorders in animals and man. <sup>(1)</sup>

2,4-dichlorophenoxyacetic acid (2,4-D) is a selective herbicide, with highest toxicity to broadleaf plants, used around houses, gardens, in agriculture and forestry. <sup>(2)</sup> 2,4-D is easily adsorbed into human from the alimentary tract and skin and excreted in the urine in nearly unchanged form. <sup>(3)</sup>

It was approved for 2,4-D to be associated with neurotoxicity, <sup>(4)</sup> hepatotoxicity, <sup>(5)</sup> immunotoxicity, <sup>(6)</sup> teratogenesis, <sup>(7)</sup> endocrine disruption, <sup>(8)</sup> and renal toxicity. <sup>(9)</sup>

It is also suggested that 2,4-D causes cell apoptosis as a result of changes in membrane potential in mitochondria and initiating of caspase-dependent reactions. <sup>(10)</sup> It is believed that the mechanism of toxicity of many compounds concerns the formation of reactive oxygen species (ROS), including superoxide anion, hydrogen peroxide, superoxide radical and hydroxyl radical.

In this study we have used FTIR spectroscopy to investigate the toxicity induced by 2,4-D onto the

cerebellum rat brain tissue, looking for a double objective:

a- To monitor the neurotoxicity and the oxidative stress induced by 2,4-D intoxication by using FTIR spectroscopy and Transmission Electron Microscope (TEM) in cerebellum rat brain tissue.

b- To prove that FTIR parameters employed in this study can be used as biophysical indicators of toxin-induced cell/or membrane damage as a result of apoptosis.

### 2. Materials and Methods

#### i- Experimental Animals

The experimental work of the present study was conducted at the King Fahd Medical Research Center, Medical Biophysics Laboratory at King Abdulaziz University, Jeddah, Saudi Arabia. This study was carried out using a total number of 15 male albino Wistar rats supplied by the King Fahd Medical Research Center, with a mean initial body weight of 250-350 g. The animals were grouped by randomized design and were housed individually in plastic cages in a room with a relative humidity of 70%, temperature of (24±1°C), and exposed to a light and dark cycle of 12 h duration. The first group (5 rats) is

the control and the second group (10 rats) is the 2,4-D treated group (2,4-D) that received a single oral gavage LD<sub>50</sub> dose of 639mg/kg body weight of 2,4-D were then sacrificed 24hrs after 2,4-D administration. All rats received the same basic diet in pellet form Grain Silos and Flour Mills Organization, Jeddah, Saudi Arabia and water as beverage. Diet and water were supplied *ad-libitum*.

The individual animal body weight was recorded then animals were killed by decapitation and brains were rapidly removed, washed with saline and then divided into two parts in Eppendorf tubes. The first part was immediately immersed in liquid nitrogen and stored at -80 °C in a deep freeze. All samples were lyophilized prior to infrared analysis. For fixation, glutaraldehyde was added to the second part for TEM analysis until assayed.

#### ii- Electron microscopy

The dissected cerebellum was fixed with glutaraldehyde in 0.2 M Phosphate buffer for 5–6 hrs at 48°C. The fixed brains were cut into approximately 1mm cubes. The cubes were post fixed in 2% OsO<sub>4</sub> for 2 hrs at 48 °C and then dehydrated in an ethanol series. The pieces were embedded in EPON/812 taab, cut into 0.5 mm thick sections using ultra microtome (LKB Sweden) and mounted on Nickel grids (300 mm). The sections were double stained with uranyl acetate and lead citrate and then examined by TEM (Philips CM100, Netherlands) and photographed.

#### iii- Infrared spectroscopic measurement

The FTIR spectra from the lyophilized samples were obtained from KBr pellets according to <sup>(11)</sup>. Infrared spectra from three rats represented each group were recorded using a Shimadzu FTIR-8400s spectrophotometer with continuous nitrogen purge. For single rat, the IR spectra were obtained from different KBr disks and then coadded. Typically, 20 scans were signal-averaged for a single spectrum and at spectral resolution of 4 cm<sup>-1</sup>. To minimize the difficulties arising from unavoidable shifts, each spectrum was baseline corrected, normalized as normalization produces a spectrum in which maximum value of absorbance becomes 2 and minimum value 0. Other normalization methods such as normalization to amide I band had also been tested and gave negligible changes in the results. Pellets were scanned at room temperature in the 4000–400 cm<sup>-1</sup> spectral range. Background spectra, which were collected under identical conditions, were subtracted from the sample spectra automatically. After co-adding all IR spectra obtained from each group, each group is now represented by one IR spectrum, the entire spectra were normalized and baseline corrected by using IR solution software. Treating the spectra with Kubelka Munk algorithm was also performed by

using the same software. Deconvolution and the best fits for decomposing the bands in the spectral region of interest were obtained by Gaussian components using Omnic software in order to increase the resolution of the overlapping bands. The parameters studied were proteins and lipids. The absorbance ratios were taken from the raw spectra.

#### Statistical analysis

Different absorbance ratios for specific bands were calculated. An analysis of variance (Mann-Whitney test) was conducted to confirm the results obtained from IR measurements.

### 3. Results

In this study, the neurotoxic effect of pesticide 2,4-D was investigated with FTIR spectroscopy by monitoring different functional groups. Representative infrared spectra of cerebellum rat brain tissue taken from cont. and 2,4-D treated groups are shown in Fig. 1a. The figure shows typical infrared spectra of biological tissues belonging to proteins, lipids carbohydrates and nucleic acids. The main absorption bands together with their proposed band assignments are given in Table 1 according to the literature. <sup>(12)(13)</sup>

Careful examination of the of the IR spectra revealed that there are no differences between the spectra of the groups under investigation apart from slight changes in the band intensities and frequencies shift.

The wide overlapping of bands in the raw spectrum results in a difficulty in band segregation and their assignment, and so using raw spectrum in the interpretation of data may not be totally conclusive as a result of noisy raw data. <sup>(14)</sup> Thus, treating the raw spectrum with Kubelka Munk algorithm, which is used here for illustrative purposes only (Fig. 1b), and/or later peak resolving may be the solution for this issue. <sup>(15)</sup>

Fig.2 shows the curve-fitting analysis, the absorption band intensities, frequencies, half band width (HBW) and area were also given in (Table 2) as the intensity and/or more accurately the area of the absorption bands are considered to be directly related to the concentration of the molecules. <sup>(16)</sup>

Detailed spectral analysis will be discussed here in three distinct frequency ranges, namely 3700-3050cm<sup>-1</sup>, 3050-2800 cm<sup>-1</sup> (C-H stretching region) and 1800-1500 cm<sup>-1</sup> respectively.

#### 1- Analysis of Hydroxyl and Hydroperoxyl Bands

The spectroscopic measurement of peroxides in brain tissue samples is usually used to determine the oxidative stress levels. Peroxide determinations can

be carried out by many different ways such as the  $\nu$ OH band of hydroperoxides located in the 3500-3000  $\text{cm}^{-1}$  region.<sup>(17)</sup> This procedure is reliable for dried samples as in case of the lyophilized brain samples enrolled in this study.

In the raw spectra, the region 3600-3050  $\text{cm}^{-1}$ , which is characterized for O-H and N-H stretching vibrations of lipids and proteins, shows important changes in the intensity and the shape of this broad band.

The band at 3300  $\text{cm}^{-1}$  corresponding to the amide A stretching mode can be associated with N-H stretching and intermolecular O-H molecules. Probable IR bands due to N-H vibrations from amide A can be hidden by the more intense O-H stretching vibrations upon oxidation.<sup>(18)</sup> The intensity of the OH stretching bands (3600  $\text{cm}^{-1}$  - 3100  $\text{cm}^{-1}$ ) reveals the degree of lipid oxidation and the amount of hydroxyl-containing lipid like cholesterol.<sup>(19)</sup>

By using a curve fit algorithm, the peaks for OH from lipids resolved into two major and two minor bands (Fig. 2a). The band intensity at 3467  $\text{cm}^{-1}$  is perceptible to the changes in the number of lipids hydroperoxyl groups formed by oxidation.<sup>(20)</sup> The other band intensities are sensitive to lipid hydroxyl groups formed by oxidation, while the amide B band centered around 3066  $\text{cm}^{-1}$  is an indicator for the protein content in the brain tissue.<sup>(19)</sup> In response to 2,4-D stress, there is a significant increase in the intensities as well as bands area of 3463  $\text{cm}^{-1}$ , 3276  $\text{cm}^{-1}$  and 3165  $\text{cm}^{-1}$  bands while a marked reduction in the area of amide B (around 3068  $\text{cm}^{-1}$ ) band is observed in comparison to the cont. group. In addition, the amide B band centered at 3068.84  $\text{cm}^{-1}$  was shifted to lower frequency (3066.37) upon 2,4-D treatment (Table 2).

These results are also confirmed with the observed decrease in specific protein ratios. Amide A/Amide B, Amide I / $\nu$ s(CH<sub>2</sub>) ratios were calculated and are used here as a spectroscopic quantitative measurements of protein content in rat brain tissue (Table 3). Upon 2,4-D intoxication, the observed decrease were [from 1.975 $\pm$  0.04, 1.385 $\pm$ 0.1 to 1.855 $\pm$  0.07, 1.349 $\pm$  0.1] in Amide A/Amide B ratio and Amide I / $\nu$ s(CH<sub>2</sub>) ratios respectively.

## 2- The region 3050-2800 $\text{cm}^{-1}$ : Symmetric and asymmetric stretching of methyl (CH<sub>3</sub>) and methylene (CH<sub>2</sub>) functional groups

Other strong bands in the spectra of these brain tissues are found to be centered in the 3000-2800  $\text{cm}^{-1}$  region, which corresponds mainly to the CH stretching vibrations of lipids hydrocarbon chains.<sup>(21)</sup>

The characteristic spectral behavior of these bands upon lipid oxidation can be considered as a

different alternative method for peroxide determinations and could be a measurement of the CH stretching bands, which because of oxidation can result in disordering of hydrocarbon lipid chains and subsequent increase of the corresponding half-band widths and/or band area.<sup>(22)</sup>

The spectral behavior of the lipid  $\nu$ CH bands in this region reflects 2,4-D oxidation. The decomposing of this region (Table 2) revealed that, primary oxidation products in the cerebellum treated brain tissue induce significant changes in the physical state of the lipid acyl chains. These changes are presented in the form of band shapes, frequency shifts, half widths, peak heights, and integrated intensity of the decomposed vibrational bands.<sup>(21)</sup> Compared with the untreated brain sample, the stretching bands of CH<sub>2</sub> groups at 2921 and 2866  $\text{cm}^{-1}$  in 2,4-D stressed samples show significant broadening (HBW) towards higher frequency (Table 2).

By contrast, the intensity, HBW and the area of the 2866  $\text{cm}^{-1}$  band relative to that of the 2921  $\text{cm}^{-1}$  band has decreased from control to 2,4-D treated sample. To explore the lipid chain polarity and order due to 2,4-D toxicity, certain lipid intensity ratios were calculated.  $\nu$ s(CH<sub>2</sub>) /  $\nu$ s(CH<sub>3</sub>) ratio is used here as a measurement of environmental polarity as it increases with the polarity of lipid chains environment and  $\nu$ s(CH<sub>2</sub>) /  $\nu$ s(CH<sub>3</sub>) ratio which is correlated with the looseness of lipid chains packing (Table 3). Also, the slight observed band shift towards higher frequency in the stretching CH<sub>2</sub> band centered at 2922.769  $\text{cm}^{-1}$  in control to 2922.899  $\text{cm}^{-1}$  in 2,4-D stressed samples indicates a change in membrane fluidity. Thus, the higher the frequency the higher the membrane fluidity.<sup>(23)</sup>

## 3-The region 1800-1500 $\text{cm}^{-1}$

In response to 2,4-D treatment, the intensity value of the amide I centered at ~1654  $\text{cm}^{-1}$  which is commonly associated with the infrared stretching vibrations of C=O in proteins is dramatically decreased (Fig. 1b). This decrease was consistent with the earlier observed decrease in the amide B band area and HBW around 3066  $\text{cm}^{-1}$  (Table 3).

For further investigation of this region, deconvolution and the best curve-fit for amide I band contour of the tested groups were carried (Fig. 2b). The data presented in (Table 4) summarize the calculated positions, the corresponding secondary structure of proteins and the fractional percentage areas of the amide I component bands from cont. and 2,4-D treated groups.

It is observed from (Table 4), that the area percentage of  $\alpha$ -helix secondary structure is decreased from 21.81% to 18.34%, while the total area

percentage of  $\beta$ -sheet structure increased from 60.05 to 66.87 due to 2,4-D toxicity.

#### 4- Analysis of Carbonyl Bands

The peak shoulder present at  $1735\text{ cm}^{-1}$  can be contributed to the ester  $\text{C}=\text{O}$  stretching of phospholipids<sup>(24)</sup>, not present in DNA and proteins. The esterified band  $\text{C}=\text{O}$  at  $1735\text{ cm}^{-1}$  is strongly associated with lipids so that any shift in the frequency of this band can be directly correlated with alterations in the state of intramolecular hydrogen bonding of the interfacial region of the phospholipids structure with water and/or some functional groups of other molecules.<sup>(25)</sup> An increase in this band intensity in response to 2,4-D toxicity was observed (Table 2).

To examine the weight of formation of carbonyl compounds against lipase action or lipid degradation during lipid oxidation, the  $\nu(\text{C}=\text{O})$  /Amide II ratio was calculated (Table 3). There is a significant increase in this ratio due to 2,4-D intoxication. The decomposing of the band around  $1735\text{ cm}^{-1}$  shows two peaks at  $\sim 1720\text{ cm}^{-1}$  and  $\sim 1741\text{ cm}^{-1}$  (Fig. 2b). The first was decreased in area from 31.87 to 30.968, while an increase in the area around  $1741\text{ cm}^{-1}$  from 28.001 to 32.901 after treatment was detected. Both bands were shifted towards higher frequency in response to 2,4-D toxicity (Table 2).

#### Electron microscopy

To provide further insight to the nature of the neuronal cell death caused by 2,4-D and in order to know if the biochemical changes observed after 2,4-D administration were strong enough to leave an impact on the morphology from control and treated group, we examined the cerebellum tissue for morphological changes by transmission electron microscopy.

At the electron microscopic level of cerebellum sections in cont. group most neurons were found to possess relatively normal cell membranes, round euchromatic nucleus (Fig. 3a) surrounded by contact nuclear envelope, small ovoid or rod shape mitochondria, short parallel rays of rough endoplasmic reticulum with attached ribosomes and secretory granules in normal nucleus – cytoplasmic ratio (Fig. 3b). It is very remarkable to mentioned that mitotic division was noticed (Fig. 3c) as cytokinesis- stage which still have the cytoplasmic connection (Fig. 3d). In 2,4-D treated group, brain cells contain numerous cells undergoing apoptosis and the majority of dying cells are neuron cells. In addition to the most well-known classical apoptosis, which is characterized by early nuclear collapse and massive condensation of chromatin with polymorph-mitochondria that have dense matrices Binukumar *et*

*al.*<sup>(26)</sup> (Fig. 3e), shows late nuclear damage type, which involves massive vacuolization of the cytoplasm with delayed collapse of the nucleus, the cytoplasm being consumed by expansion of the lysosomal system, mitochondrial matrix swelling and loss of mitochondrial cristae with dilatation and vesiculation of rough endoplasmic reticulum (Fig. 3f) the same results were obtained by Kaur *et al.*<sup>(27)</sup> and Sharma *et al.*<sup>(28)</sup>

#### 4. Discussion

The mechanism of toxicity of many compounds concerns the formation of reactive oxygen species (ROS), including superoxide anion, hydroperoxide, superoxide radical and hydroxyl radical. These compounds are capable of reacting with proteins, nucleic acids, lipids and/ or molecules that lead to changes in their structure and finally to cell damage or cell death.<sup>(29)</sup>

Oxidative stress has been proved to occur in response to different doses of pesticides as 2,4-D<sup>(5)</sup> leading to neurochemical changes.<sup>(22)</sup> Therefore, the spectroscopic measurement of peroxides in brain tissue samples is of interest to determine levels of the oxidative stress.

**Table.1:** General assignment of the FTIR spectra of brain tissue in the  $3600\text{--}445\text{ cm}^{-1}$  spectral rang

Wave number ( $\text{cm}^{-1}$ )	Band assignments
3301	Amide A: mainly $\nu(\text{N-H})$ of proteins
3072	Amide B: $\nu(\text{N-H})$ of proteins
3014	Olefinic $\nu(\text{HC=CH})$ : lipids
2956	$\nu_{\text{as}}(\text{CH}_3)$ : mainly lipids
2921	$\nu_{\text{as}}(\text{CH}_2)$ : mainly lipids
2873	$\nu_{\text{s}}(\text{CH}_3)$ : mainly protein
2852	$\nu_{\text{s}}(\text{CH}_2)$ : mainly lipids
1735	Carbonyl $\nu(\text{C=O})$ : lipids
1654	Amide I: $\nu(\text{C=O})$ of proteins
1544	Amide II: $\delta(\text{N-H})$ and $\nu(\text{C-N})$ of proteins
1462	$\delta(\text{CH}_2)$ stretch: mainly lipids
1396	$\nu_{\text{s}}(\text{COO}^-)$ : fatty acids and amino acids
1236	$\nu_{\text{as}}(\text{PO}_4^{2-})$ : mainly phospholipids
1082	$\nu_{\text{s}}(\text{PO}_4^{2-})$ : mainly nucleic acids; $\nu(\text{HO-C-H})$ : carbohydrates
1000-455	Fingerprinting region: mainly nucleic acids

( $\nu$ : stretching vibrations,  $\delta$ : bending vibrations, s: symmetric, as: asymmetric).

**Table 2:** Wave numbers, intensities, HBWs and areas of different IR spectral regions.

Groups	Wave number (cm <sup>-1</sup> )	Intensity	HBW	Area
<b>The region 3600-3050 cm<sup>-1</sup> (Hydroxyl and Hydroperoxyl)</b>				
Cont.	3463.486	3.746	257.786	1027.984
	3276.96	3.437	199.243	728.926
	3165.49	0.752	83.283	66.637
	3068.848	1.583	115.399	194.422
2,4-D	3467.536	4.026	273.577	1172.24
	3272.619	3.367	209.578	751.24
	3157.246	0.806	90.298	77.46
	3066.365	1.586	100.46	169.587
<b>The region 3050-2800 cm<sup>-1</sup> (CH<sub>3</sub>) and (CH<sub>2</sub>)</b>				
Cont.	2962.205	1.506	26.507	42.483
	2922.769	4.047	43.021	185.349
	2858.683	2.174	53.432	123.671
2,4-D	2962.741	1.486	26.948	42.624
	2922.849	3.962	44.627	188.229
	2858.58	2.175	52.553	121.646
<b>The region 1800-1500 cm<sup>-1</sup> (carbonyl bands)</b>				
Cont.	1741.302	1.437	18.307	28.001
	1720.75	1.152	25.993	31.87
2,4-D	1741.52	1.6517	18.7128	32.901
	1722.045	1.2551	23.179	30.968

**Table 3:** IR intensity absorbance ratios with standard deviation as spectroscopic quantitative measurements of protein content and membrane lipid environment in rat brain tissue.

Ratios/Groups	Cont.	2,4-D
Amide A/B	1.9753 ± 0.04	1.8548 ± 0.07*
Amide I /vs(CH <sub>2</sub> )lipids	1.3848 ± 0.1	1.3498 ± 0.1
vs(CH <sub>2</sub> )lipids/ vs(CH <sub>3</sub> )lipids	1.2509 ± 0.04	1.1870 ± 0.06*
vs(CH <sub>2</sub> )lipids/ vs(CH <sub>3</sub> )Lipids	1.9083 ± 0.05	1.8148 ± 0.07*
v(C=O)lipids/Amide II	0.4595 ± 0.03	0.5103 ± 0.02*

Values are means±S.D. For three rats each group. Significance is at  $p < 0.01$ . \* means highly significant.

**Table 4.** Curve fitting analysis expressed as a function of areas of main protein secondary structures and their band assignments for control and 2,4-D intoxicated brain tissues.

Wave number (cm <sup>-1</sup> )	Band assignment	Cont. area % percentage	2,4-D area % percentage
1612-1621	β-turns	13.13	13.12
1634-1639 1641	Parallel unordered structure	18.15	14.77
1650-1657	α-helix	21.81	18.34
1666-1669	β-turns	31.66	28.68
1672-1677	Parallel β-sheets	1.39	7.96
1681-1687	β-sheets	3.22	7.71
1694-1698	Anti-parallel β-sheets	10.65	9.4

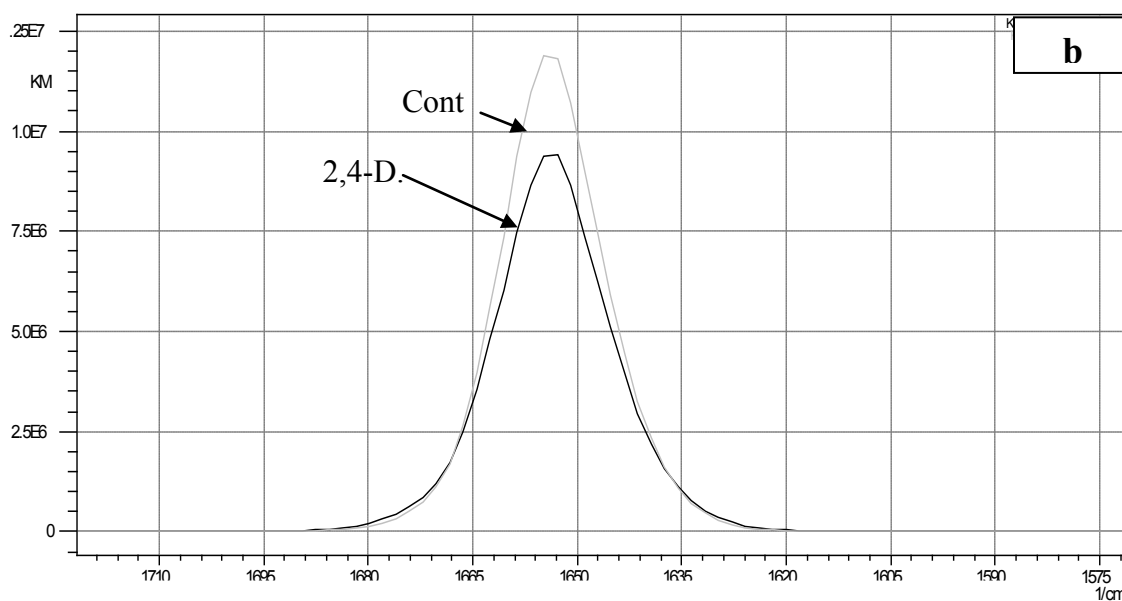
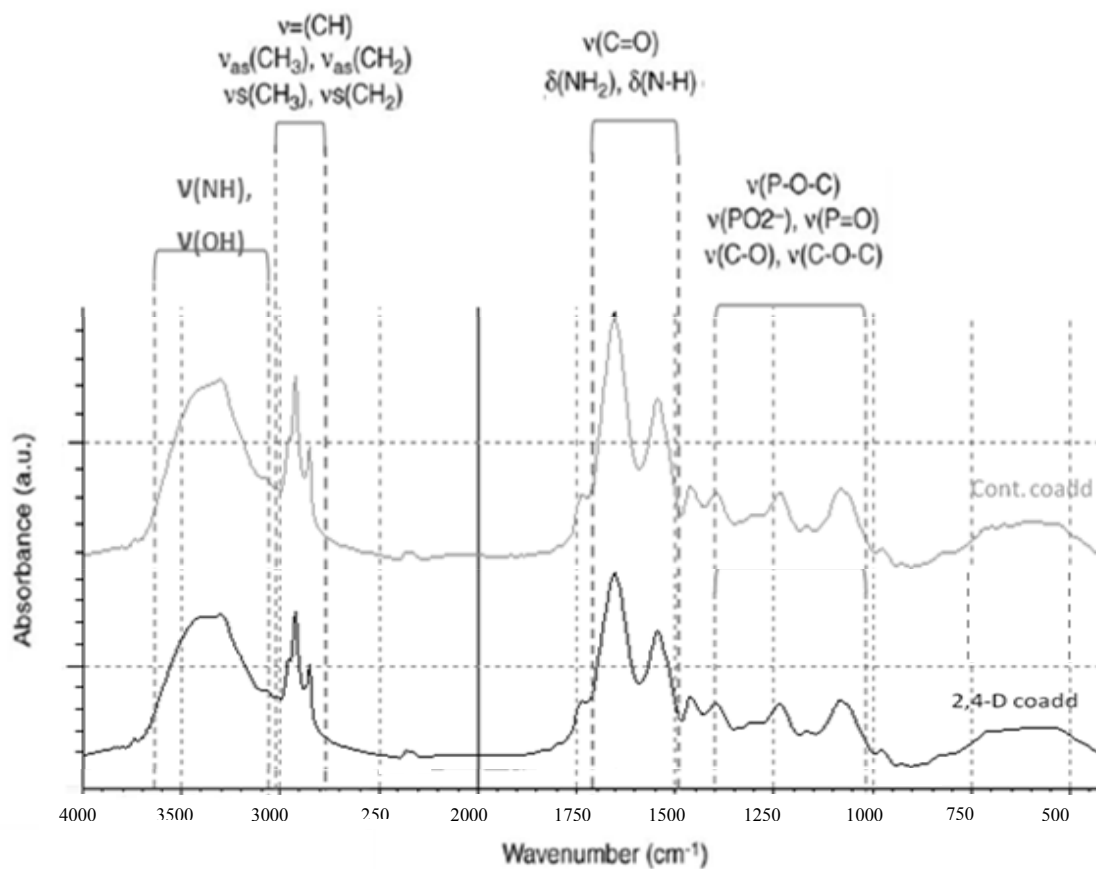

**Fig. 1: (a)** FTIR spectra of cont. and 2,4-D treated rat cerebellum brain tissue. Characteristic functional groups at specific wave numbers are indicated in the figure.

**(b)** Kubelkamunk spectra of brain tissue of cont. and 2,4-D treated group in the 1800-1500 $\text{cm}^{-1}$  IR spectral region.



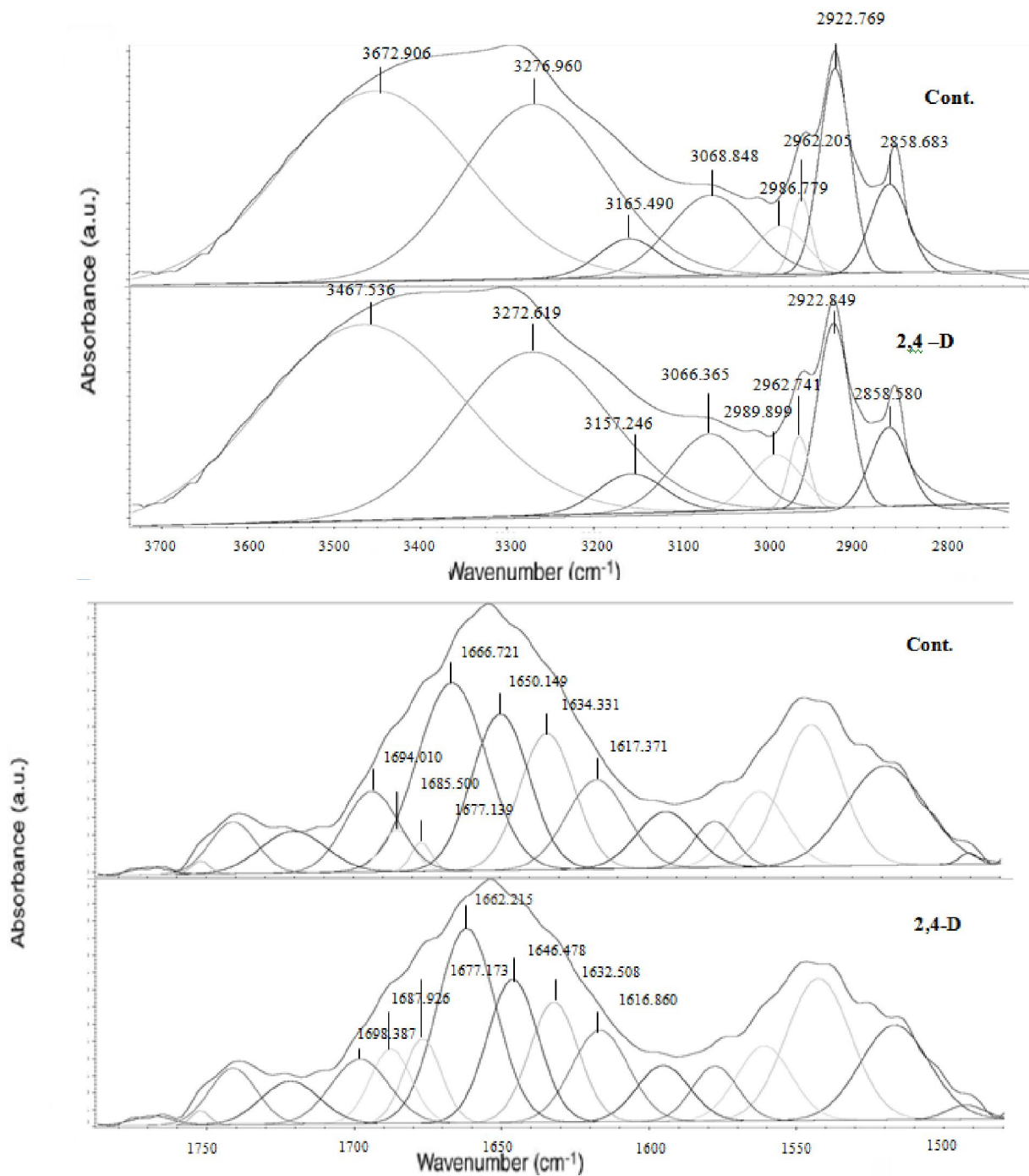

**Fig. 2: (a)** Curve fitting of brain tissues of cont. and 2,4-D group in the FTIR 3700-2700 $\text{cm}^{-1}$  spectral range (O-H, N-H stretching and CH vibrations).  
**(b)** Deconvolution and Curve fitting for the amide I amide band in brain tissue for control and 2,4-D groups.

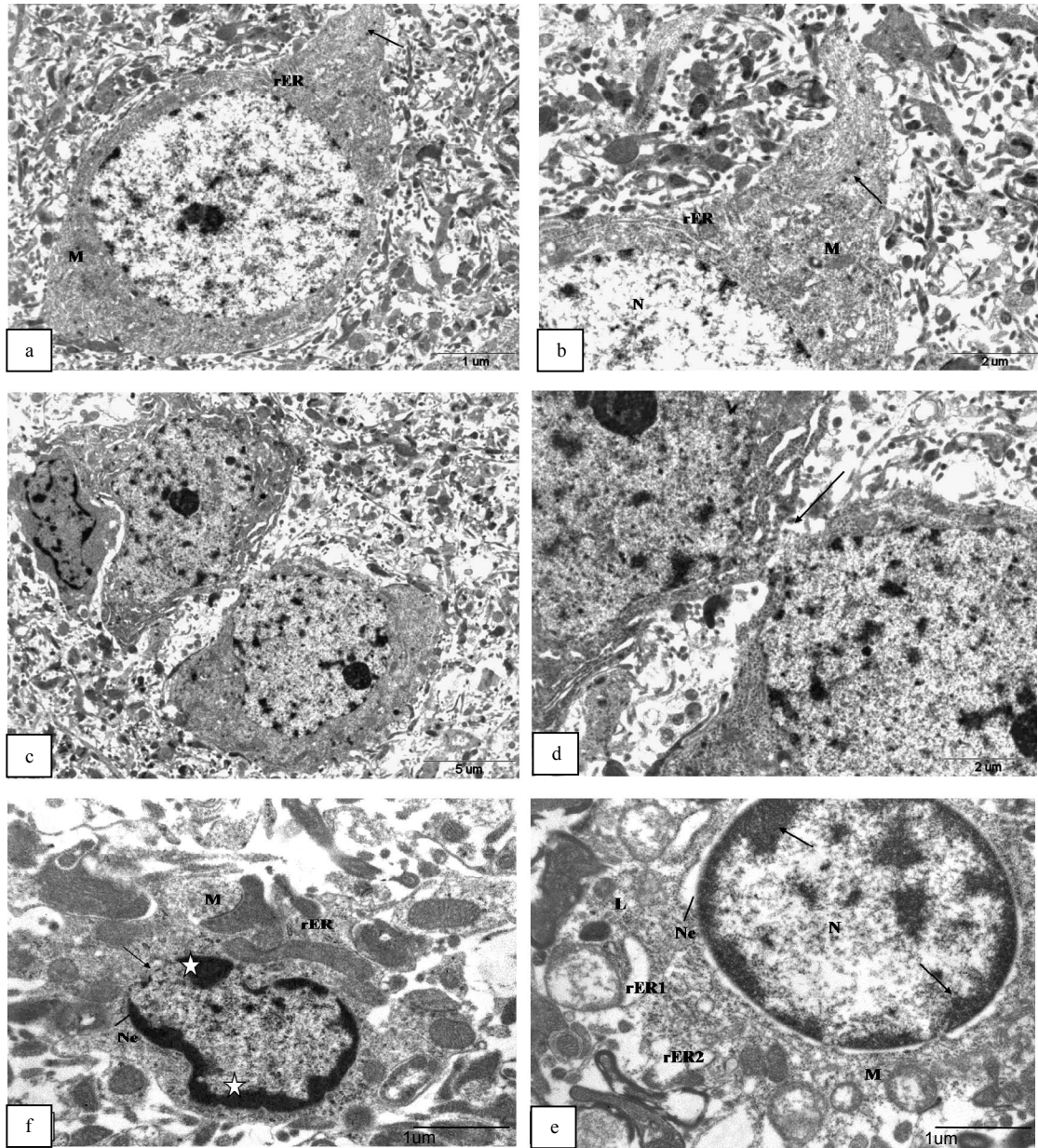

**Figure 3:** Transmission electron micrograph of the control cerebellum of rat brain sacrificed after 24h showing  
**(a)** : Normal appearance of neuron with tree-like dendritic (arrow) have nucleus (N) ,small ovoid mitochondria (M), rough endoplasmic reticulum (rER) in normal nucleus –cytoplasmic ratio (x4600).  
**(b)** Enlarged part of the pervious figure showing: Normal nucleus (N) surrounded by contact nuclear envelope ,small ovoid mitochondria (M), long parallel rays of rough endoplasmic reticulum (rER) with attached ribosomes and secretory granules (arrow) (x7900).  
**(c)** Control cerebellum of rat brain sacrificed after 24h showing mitotic division in cytokinesis stage (x3400).  
**(d)** Enlarged part of the pervious figure showing: Normal neuron cell in cytokinesis stage still have the cytoplasmic connection (arrow) (x7900).  
**(e)** Cerebellum of rat brain sacrificed 24h after 2,4-D treatment showing: apoptotic cell with shrinkage neuron nucleus (N) have chromatin condensation (stars) , wide pores (arrows) and contact nuclear envelope (Ne) . Polymorph-mitochondria (M) with dense matrix and rough endoplasmic reticulum (rER)(x13500).  
**(f)** Another apoptotic cell from same group with round neuron nucleus (N) have chromatin condensation (arrows) and surrounded by dilated nuclear envelope (Ne). Not, swollen mitochondria (M) with loss of cristae, dilated rough endoplasmic reticulum (rER1) or vesiculated (rER2) with detached ribosomes and lysosome (x13500). (Lead citrate & uranyl acetate).

The significant increase in the intensity as well as band area of  $3463\text{cm}^{-1}$ ,  $3276\text{cm}^{-1}$  and  $3165\text{cm}^{-1}$  bands upon 2,4-D intoxication could be attributed to an increase in lipid oxidation as the intensity of the OH stretching bands ( $3600\text{cm}^{-1}$  -  $3100\text{cm}^{-1}$ ) reflects the degree of lipid oxidation and the amount of hydroxyl-containing lipid such as cholesterol.<sup>(19)</sup> Hydrophilic OH groups added to the hydrophobic region of lipid hydrocarbon chains with oxidation would be expected to disrupt Van der Waal's interactions between adjacent hydrocarbon chains, thus disordering the membrane.<sup>(19)</sup> Compared with the untreated brain sample, the stretching bands of  $\text{CH}_2$  groups at  $2921\text{cm}^{-1}$  and  $2866\text{cm}^{-1}$  in 2,4-D stressed samples show significant broadening (HBW) towards higher frequency. This means that, upon oxidation, the lipid chains are more disordered and there is conversion of lipid hydrocarbon chain *trans* rotomers to more *gauche* rotomers, which results in the mentioned band broadening and frequency shift (Table 2). These results agree with Borchman *et al.*<sup>(19)</sup> who stated lower frequencies indicated fewer *gauche* rotomers and higher hydrocarbon chain order. The intensity, HBW and the area of the  $2866\text{cm}^{-1}$  band relative to that of the  $2921\text{cm}^{-1}$  band has decreased on going from control to 2,4-D treated sample, this result is consistent with<sup>(31)</sup>, which can be explained as follows: the band at  $2866\text{cm}^{-1}$  is generated just by symmetric stretching of  $\text{CH}_2$  groups, whereas the  $2921\text{cm}^{-1}$  band is attributed to contributions of asymmetric and symmetric motions of  $\text{CH}_2$  and  $\text{CH}_3$  groups respectively. In addition, the relative intensity of  $2921\text{cm}^{-1}$  band can be influenced by methane C-H stretching absorption near  $2900\text{cm}^{-1}$ <sup>(31)</sup>, which results from oxidation of  $\text{CH}_2$  groups to hydroxymethine groups. It is well known that  $\text{CH}_3$  groups exhibit a minor susceptibility to oxidation than that of  $\text{CH}_2$  groups, since the lipid acyl chains are oriented within the cell membrane so that the methyl groups are located in the hydrophobic interior.<sup>(22)</sup> At the same time, the reduced  $\text{vas}(\text{CH}_2) / \text{vs}(\text{CH}_3)$  intensity ratio in 2,4-D treated brain tissue is also indication of higher lipid acyl chain unsaturation and polarity, which is known to occur with lipid acyl chain peroxidation.<sup>(32)</sup>

Cecilia *et al.*,<sup>(23)</sup> studied the perturbation of membrane dynamics in nerve cells during bilirubin-induced apoptosis by using spin labels and electron paramagnetic resonance spectroscopy analysis of whole cell and isolated mitochondrial membrane. Our results agree with their results and we can say assertively that, by physically interacting with cell membranes, 2,4-D induced decrease in lipid polarity sensed at a superficial level, increased the disorder and the looseness of lipid chain packing and increase the membrane fluidity. The enhanced membrane permeability coincided with an increase in lipid

fluidity and protein mobility and was associated with significant oxidative injury to membrane lipids.<sup>(23)</sup> Tushel & Schwab<sup>(33)</sup> studied the cytotoxic effects of the herbicide 2,4-D in hepatoma cell line HepG2. They suggested that the induction of apoptosis in HepG2 cells by 2,4-D was accompanied by disruption of the mitochondrial membrane potential as verified by staining with the cationic JC-1 probe. Moreover, upon 2,4-D toxicity, the formation of carbonyl compounds against lipase action or lipid degradation during lipid oxidation was significantly increased. As 2,4-D proved to induce apoptosis to nerve cells, apoptosis involves biochemical changes on DNA, protein and lipid, protein synthesis and/or the modification of existing proteins (such as caspases). Lipids are also heavily involved in apoptosis. DNA fragmentation, activation of caspases and externalization of phosphatidylserine are considered to be three biomarkers of apoptosis.<sup>(34)</sup> These results consistent with those found earlier, which suggest that the peaks at  $1745$ (cholesterol and triglycerides ester C=O),  $1720$ (carbonyl C-O stretch), and  $1621\text{cm}^{-1}$ (peptide C=O stretch) are positively correlated with LDL oxidation.<sup>(35)</sup>

These results strongly suggest that membrane phospholipids of brain tissue are attacked by free radical during oxidative stress mediated by 2,4-D treatment, which affect the lipid structure and lipid acyl chains saturation.<sup>(36)</sup> As 2,4-D is capable of binding itself with proteins, protein damage may be the result of direct impact of 2,4-D or its indirect effect, for example by generation of free radicals that results in protein peroxidation.<sup>(10)</sup>

The marked reduction observed in the area of amide B (around  $3068\text{cm}^{-1}$ ) band from  $194.422$  to  $169.587$  in the 2,4-D treated tissues together with the shift to lower frequency from  $3068.848\text{cm}^{-1}$  to  $3066.365\text{cm}^{-1}$  upon 2,4-D treatment is an indicative to a decrease in protein content.<sup>(13)</sup> These results are consistent with the observed significant reduction in the intensity as well as area of amide I bands around  $1654\text{cm}^{-1}$  in the brain spectrum due to 2,4-D intoxication which can be considered as a strong evidence of the decrease in the protein quantity of the system. This decrease is in agreement with the decreased observed in the Amide A/Amide B, Amide I / $\text{vas}(\text{CH}_2)$ lipids ratios together with the observed band shift of the amide B band which is shifted to lower values due to the toxic effect of 2,4-D. This could be a sign of the destructive effect of 2,4-D and could be attributed to a change in the composition of the whole protein pattern.<sup>(37)</sup> Cakmak *et al.*,<sup>(38)</sup> have also observed decreasing intensity in amide A and amide I bands, trend in rainbow trout liver treated with  $17\beta$  estradiol and nonylphenol. They elucidated this decreases in intensities of protein bands to alteration

of the protein synthesis and protein structure due to toxicities. Palaniappan and Vijayasundaram<sup>(13)</sup> also found a significant decrease in the intensity of amide A and amide I bands of the brain tissue of Labeo rohita due to arsenic intoxication, suggesting a decrease in protein quantity of rat brain tissue.

FTIR spectroscopy is one of the major techniques for the determination of protein secondary structures in various tissues.<sup>(39)</sup> After deconvolution and curve fitting to the amide I and amide II bands it was observed that the total area of  $\alpha$ -helix secondary structure is decreased, while the total area of  $\beta$ -sheet structures increased due to the toxic effect of 2,4-D. The decrease in  $\alpha$ -helix structure of the cerebellum brain tissues might be responsible for the increase in  $\beta$ -sheet structure, which was consistent with the mechanism of  $\beta$ -sheet formation.<sup>(13,40)</sup> It is known that the  $\beta$ -sheet structure content in proteins can be formed by thermal-, salt- or solvent-induced aggregation<sup>(41)</sup> as a result of proteins denaturation. The  $\beta$ -sheet structure in 2,4-D intoxicated brain tissues suggests that the increase of the intermolecular hydrogen-bond interactions forms aggregates of higher molecular weight, and then modifies the secondary structure of proteins in brain tissues.<sup>(40)</sup> In apoptotic cells there is a significant intensity decrease in the region between 900-1300  $\text{cm}^{-1}$ , which corresponds to the nucleic acid bands, with respect to viable cells.<sup>(42)</sup> This finding was consistent with our results since there is a marked reduction in this band area upon 2,4-D intoxication (data not shown). It is also agree with the results obtained by Liu and Mantsch<sup>(43)</sup> when they describe a new analytical method, based on infrared (IR) spectroscopy, to estimate the percentage of apoptotic leukemic cells in two different cell lines (CEM and K562), induced with etoposide (VP-16). They detected changes in protein secondary structure, the increase in the overall lipid content and the decrease in the amount of detectable DNA. The above mentioned results which characterize the IR spectral signatures, indicative of apoptosis, were also supported morphologically by the transmission electron microscope analysis.

Cerebellar granule cells showed that 2,4-D induced apoptosis to exposed cells.<sup>(44)</sup> Apoptotic cells were characterized by chromatin margination to nuclear membrane and shrinkage of cell cytoplasm which is consistent with Kaur *et al.*<sup>(27)</sup>. Apoptosis is a mechanism that is regulated by genes and includes engagement of some receptors such as Fas and TNF receptor 1, by their ligands, or by agents that disrupt the integrity of the cell. Some chemotherapeutic drugs, may also cause caspase-dependent as well as caspase-independent cell death mechanisms.<sup>(45)</sup>

The present results showed that the electron microscopic examination of 2,4-D treated rat brain

revealed that mitochondria undergo various morphological changes such as swelling, loss of cristae and cytoplasm shrinkage and chromatin fragmentation signifying apoptotic changes as compared to control ones which exhibited normal and intact mitochondria which agree with Kaur *et al.*<sup>(27)</sup> who found that ultra structural changes shown by electron microscopy examination of rat brain following 2,4-D exposure provided a clear evidence that 2,4-D-induced morphological changes were consistent with apoptotic cell death.<sup>(27)</sup>

It has also been reported that 2,4-D induced neurotoxicity may be due to generation of free radicals.<sup>(30)</sup> When incubating rat cerebellar granule cells with 2,4-D *in vitro*, generation of reactive oxygen species (ROS) and activity of selenium-glutathione peroxidase (Se-GPx) are augmented.<sup>(37)</sup> Furthermore, chlorophenoxy acids structures are related to acetic acid and can form analogues of acetyl-CoA (e.g. 2,4-D-CoA) *in vitro*. Formations of such analogues can disrupt several pathways involving acetyl-CoA, including the synthesis of acetylcholine. Possible formation of choline esters may act as false cholinergic messengers.<sup>(46)</sup>

Oxidative damage occurs in mitochondria more than any other organelles in the cell because the existence of the respiratory chain in the mitochondria leads to the formation of damaging ROS. This oxidative damage may modify mitochondrial proteins, DNA and lipids which leads to mitochondrial bioenergetics failure leading to necrotic or apoptotic cell death.<sup>(47)</sup>

Further, it has been demonstrated that apoptosis and necrosis are connected with structural and functional alterations in mitochondrial membranes exposed to 2,4-D. Chlorophenoxy herbicides can also disrupt cell membrane transport mechanisms by competitively inhibiting and saturating the organic anion transport system in the choroid plexus, which facilitates the removal of toxic anions.<sup>(48)</sup>

## Conclusion

To conclude, by using FTIR and EM morphologic analysis of cerebellum rat brain tissue exposed to 2,4-D, we detected major membrane perturbation. By physically interacting with cell membranes, 2,4-D induced an almost immediate decrease in lipid polarity sensed at a superficial level, increased the disorder and the looseness of lipid chain packing and increase the membrane fluidity. Moreover, a remarkable decrease in protein content and a change in secondary structure were evident. Thus, with addition to the morphological changes, all of which can be considered as apoptosis biomarkers. As apoptosis involves biochemical changes on DNA, protein and lipid in addition to membrane perturbation

features, FTIR spectroscopy proved to be able to observe changes in individual living cells resulting from various agents that may induce apoptosis.

### Acknowledgments

Mr. Zaki Al-Asouli, Dr. Neamat Kotb, Dalal Albaroudi, Nourah Al-Otaibi, Rasha Ahmed, Rula Habbal, Mr. Mohammad Refai and Amal Al- Mustadi.

This research work was supported by King Abdulaziz City for Science and Technology; grant number: AT-125-18

### Corresponding authors

#### Gehan A. Raouf

Medical Biophysics Lab., King Fahd Medical Research Centre; Biochemistry Dept., King Abdulaziz University, 21551 Jeddah –KSA B.O.Box:42805, Spectroscopy Dep. Physics Div.-National Research, Cairo- Egypt.

[gehan\\_raouf@hotmail.com](mailto:gehan_raouf@hotmail.com) - [jahmed@kau.edu.sa](mailto:jahmed@kau.edu.sa)

### References

- Raseir, G., J. Toppari, P. A.S., and J. B. Bourguignon., 2006. Female sexual maturation and reproduction after prepubertal exposure to estrogens and endocrine disrupting chemicals: A review of rodent and human data. *Mol. Cell Endocrinol.* **254-255**: 187–201.
- Garabrant D.H., and M.A. Philbert. 2002. Review of 2,4-dichlorophenoxyacetic acid (2,4-D) epidemiology and toxicology. *Crit. Rev. Toxicol.* , **32**: 233.
- Brand R.M., M. Spalding, and C. Mueller. , 2002. Sunscreens Can Increase Dermal Penetration of 2,4-Dichlorophenoxyacetic Acid. *Clin. Toxicol.* , **40**: 827.
- Bortolozzi, A., A. M. Evangelista de Duffard, F. Daja, R. Duffard, and R. Silveira. 2001. Intracerebral administration of 2,4-dichlorophenoxyacetic acid induces behavioral and neurochemical alterations in the rat brain. *Neurotoxicology.* **22**: 221–232.
- Tayeb, W., A. Nakbi, M. Trabelsi, N. Attia, A. Miled, and M. Hammamia. , 2010. Hepatotoxicity induced by sub-acute exposure of rats to 2,4-dichlorophenoxyacetic acid based herbicide “désormone lourde”. *Journal of Hazardous Materials.* **180**: 225-33.
- Lee, K., V. L. Johnson, and B. R. Blakley. 2001. The effect of exposure to a commercial 2,4-d formulation during gestation on the immune response in cd-1 mice. *Toxicology.* **165**: 39–49.
- Morgan, M. K., P. R. Scheuerman, C. S. Bishop, and R. A. Pyles. , 1996. Teratogenic potential of atrazine and 2,4-d using fetax. *Journal of Toxicology and Environmental Health.* **48**: 58–61.
- Garry, V. F., R. E. Tarone, I. R. Kirsch, J. M. Abdallah, D. P. Lombardi, L. K. Long, B. L. Burroughs, D. B. Barr, and J. S. Kesner. , 2001. Biomarker correlations of urinary 2,4-d levels in forester: Genomic instability and endocrine disruption. *Environmental Health Perspectives.* **109**: 495–500.
- Gomez, L., F. Soler, S. Martinez, A. Gazquez, E. Duran, and V. Roncero. , 1999. 2,4-d treatment in tench (*tinca tinca* l.): Pathological processes on the excretory kidney. *Bulletin of Environmental Contaminants and Toxicology.* **62**: 600–607.
- Bukowska, B. 2006. Toxicity of 2,4-dichlorophenoxyacetic acid – molecular mechanisms. *Polish J. of Environ. Stud.*, **15**: 365-374.
- Raouf, G. A., A. Al-Malki, N. Mansouri, and R. Mahmoudi. , 2011. Preliminary study in diagnosis and early prediction of preeclampsia by using FTIR spectroscopy technique. *Life Science Journal.* **8**: 827-836.
- Akkas, S. B., M. Severcan., O. Yilmaz, and F. Severcan., 2007. Effects of lipoic acid supplementation on rat brain tissue: An ftir spectroscopic and neural network study. *Food Chemistry*, **105**: 1281–1288.
- Palaniappan, P., and V. Vijayasundaram. 2009. The FTIR study of the brain tissue of labeo rohita due to arsenic intoxication. *Microchemical J.* , **91**: 118-124.
- Sasic, S., M. Morimoto, M. Otsuka, and Y. Ozaki. , 2005. Two—dimensional correlation spectroscopy as a tool for analyzing vibrational images. *Vibr. Spec.* **37**: 217–24.
- D’Souza, L., P. Devi, M.P. Shridhar, and G. Naik. , 2008. Use of Fourier Transform Infrared (FTIR) Spectroscopy to Study Cadmium-Induced Changes in Padina Tetrastrum. *Analytical Chemistry Insights.* **3**: 135–143.
- Severcan F., G. Gorgulu, G. T.S., and G. T. , 2005. Rapid monitoring of diabetes-induced lipid peroxidation by fourier transform infrared spectroscopy: Evidence from rat liver microsomal membranes. *Anal. Biochem.* , **339**: 36-40.
- Carmona, P., A. Rodry’guez-Casado, I. Alvarez, I. de Miguel, and A. Toledano. 2008. Ftir microspectroscopic analysis of the effects of certain drugs on oxidative stress and brain protein structure,. *Biopolymers.* **89**: 548-554.
- Crupi, V., D. Majolino, P. Migliardo, M. R. Mondello, M. P. German, and S. Pergolizzi. , 2001. Ft-ir molecular evidence of liver damage by chemical agents. *Vibrational Spectroscopy.* **25**: 213-222.
- Borchman, D., F. Giblin, V. Leverenz, V. Reddy, Lin Li-Ren, M. Yappert, D. Tang, and L. Li. , 2000. Impact of aging and hyperbaric oxygen *in vivo* on guinea pig lens lipids and nuclear light scatter. *Invest Ophthalmol Vis Sci.* , **41**: 3061–3073.
- Van de Voort, F. R., A. A. Ismail, J. Sedman, and G. Emo. , 1994. Monitoring the oxidation of edible oils by fourier transform infrared spectroscopy. *J Am Oil Chem Soc.* , **71**: 243–253.
- Fraile M. V., B. Patrón-Gallardo, G. López-Rodríguez, and C. P. , 1999. Ftir study of multilamellar lipid dispersions containing cholesteryl linoleate and dipalmitoylphosphatidylcholine. *Chem. Phys. Lipids.* **97**: 119-128.
- Rodriguez-Casado J., M. I. Alvarez, E. De Miguel, T. A., and P. Carmona. , 2007. Amphetamine effects on oxidative stress and formation of proteic beta-sheet structures as revealed by ftir microspectroscopy. *Biopolymers.* **86**: 437-446.

23. Cecilia, M. P., S. Susana, E. Rui, A. Pedro, B. Dora, J. José, and G. Moura. , 2002. Perturbation of membrane dynamics in nerve cells as an early event during bilirubin-induced apoptosis. *Journal of Lipid Research*. **43**: 885-894.
24. Diem, M., S. Boydston-White, and L. Chiriboga. , 1999. Infrared spectroscopy of cells and tissues. Shining light onto an unsettled subject. *Appl. Spectrosc.* **53**: 148A-161A.
25. Takahashi, H., S. W. French, and P. T. T. Wong. , 1991. Alterations in hepatic lipids and proteins by chronic ethanol intake: A high pressure fourier transform infrared spectroscopic study on alcoholic liver disease in the rat. *Alcoholism-Clinical and Experimental Research*. **15**: 219-223.
26. Binukumar, B. K., B. Amanjit, K. Ramesh, and D. G. Kiran., 2010. Nigrostriatal neuronal death following chronic dichlorvos exposure: crosstalk between mitochondrial impairments, a synuclein aggregation, oxidative damage and behavioral changes. *Molecular Brain*. **3**: 35-55.
27. Kaur, P., B. Radotra, R. W. Minz, and K. D. Gill., 2007. Impaired mitochondrial energy metabolism and neuronal apoptotic cell death after chronic dichlorvos (OP) exposure in rat brain. *Neurotoxicology*. **28**: 1208-1219.
28. Sharma, Y., S. Bashir, M. Irshad b, T. C. Nagc, and T. D. Dogra. , 2005. Dimethoate-induced effects on antioxidant status of liver and brain of rats following subchronic exposure. *Toxicology*. **215**: 173-181.
29. Mates, J. M. , 2000. Effects of antioxidant enzymes in the molecular control of reactive oxygen species toxicology. *Toxicology*. **153**: 83-104.
30. Bukowska, B., B. Rychlik, A. Krokosz, and J. Michalowicz. , 2008. Phenoxyherbicides induce production of free radicals in human erythrocytes: Oxidation of dichlorofluorescein and dihydrorhodamine by 2,4-d-na and mcpa-na. *Food Chem. Toxicol.* **46**: 359-367.
31. Socrates, G. 2001. Infrared and Raman characteristic groups frequencies. Tables and charts, Chichester: Wiley press.
32. Petibois, C., G. Cazorla, J. R. Poortmans, and G. Déléris. , 2003. Biochemical aspects of overtraining in endurance sports: The metabolism alteration process syndrome. *Sports Medicine*. **33**: 83-94.
33. Tuschl, H. and C. Schwab. , 2003. Cytotoxic effect of the herbicide 2,4-dichlorophenoxyacetic acid in hepg2 cells. *Food and Chemical Toxicology*, **41**: 385-393.
34. Thompson, C. B. 1995. Apoptosis in the pathogenesis and treatment of disease. *Science*. **267**: 1456-1462.
35. Mantsch, H. H. , 2001. Apoptosis-induced structural changes in leukemia cells identified by ir spectroscopy. *J. Mol. Str.* **565-566**: 299-304.
36. Inouyea, M., T. Miob, and K. Suminob. , 1999. Formation of 9-hydroxy linoleic acid as a product of phospholipid peroxidation in diabetic erythrocyte membranes. *Biochem. Biophys. Acta*. **1438**: 204-212.
37. Bongiovanni, B., P. De Lorenzi, A. Ferri, C. Konjuh, M. Rassetto, A. M. Evangelista de Duffard, D. P. Cardinali, and R. Duffard. , 2007. Melatonin decreases the oxidative stress produced by 2,4-dichlorophenoxyacetic acid in rat cerebellar granule cells. *Neurotox Res.* **11**: 93-99.
38. Cakmak G., T. I., and F. Severcan. , 2006. 17b-estradiol induced compositional, structural and functional changes on rainbow trout liver, revealed by ftir spectroscopy: A comparative study with nonylphenol. *Aquatic Toxicology*. **77**: 53-63.
39. Severcan, F., and P. Haris. , 2003. The main unfolding and aggregation of pcs is preceded by the unfolding of a minor structure at lower temperature. *Biopolymers*. **69**: 440-447.
40. Creighton, T. , 1984. Pathways and mechanisms of protein folding. *Adv. Biophys.* **18**: 1-20.
41. Kim, Y., C. A. Rose, Y. Liu, Y. Ozaki, G. Datta, and A. T. Ut. , 1994. Ft-ir and near-infrared ft-raman studies of the secondary structure of insulinotropin in the solid state: Á-helix to â-sheet conversion by phenol and/or high shear force. *J Pharm Sci.* **83**: 1175-1180.
42. Fabio, G., and M. Marta. , 2003. Monitoring of apoptosis of HL60 cells by Fourier-transform infrared spectroscopy. *Biochem. J.* **369**: 239-248.
43. Liu, K. Z., and H. H. Mantsch. , 2001. Apoptosis-induced structural changes in leukaemia cells identified by IR spectroscopy. *J Mol Struct.* **565-566**: 299-344.
44. De Moliner, K. L., A. M. Evangelista de Duffard, E. Soto, R. Duffard, and A. M. Adamo. , 2002. Induction of Apoptosis in Cerebellar Granule Cells by 2,4-Dichlorophenoxyacetic Acid. *Neurochemical Research*. **27**: 1439-1446.
45. Glaser, T., B. Wagenknecht, P. Groscurth, P. H. Krammer, and M. Weller. , 1999. Death ligand/receptor-independent caspase activation mediates drug-induced cytotoxic cell death in human malignant glioma cells. *Oncogene*. **18**: 5044-5053.
46. Bradberry S.M., B.E. Watt, A.T. Proudfoot. and J.A. Vale. , 2000. Mechanism of toxicity, clinical features and management of acute chlorophenoxy herbicide poisoning: a review. *Clin. Toxicology*. **38**: 111-122.
47. Smith, R. A. J., C. M. Porteous, and C. M. Murphy. , 1999. Selective targeting of an antioxidant to mitochondria. *Eur J Biochem*. **263**: 709-16.
48. Kim, C. S., and J. B. Pritchard. 1993. Transport of 2,4,5-trichlorophenoxyacetic acid across the blood-cerebrospinal fluid barrier of the rabbit. *J. Pharmacol. Exp. Ther.* **267**: 751-757.

## Noun Phrases in Vafs Dialect

Fatemeh Moosavi mirak<sup>1</sup>, Nasrin Safavizadeh<sup>2</sup>

<sup>1</sup> Member of Scientific Board, Faculty of Social Sciences, Islamic Azad University, Arak Branch

<sup>2</sup> Member of Scientific Board, Faculty of Social Sciences, Islamic Azad University, Arak Branch

[f-moosavi@iau-arak.ac.ir](mailto:f-moosavi@iau-arak.ac.ir)

**Abstract:** The dialect of Vafs is one of the dialects on the northwest of Iran. Rich, original vocabulary, idioms, phones, verbs and grammar of this dialect characterize this dialect as one of the ring of the chain connecting medial Persian to modern Persian. This paper tries to study the structures and the forms of the "nouns" of this dialect, and to compare some of its words with their counterparts in ancient and modern languages of Iran.

[Fatemeh Moosavi mirak, Nasrin Safavizadeh. **Noun Phrases in Vafs Dialect.** *Life Sci J* 2012;9(4):1698-1703] (ISSN:1097-8135). <http://www.lifesciencesite.com>. 260

**Key words:** Vafs, dialect, language, Noun Phrases, Iranian Languages.

### Introduction

Local languages and dialects are rich sources for studies in the fields of language, literature, sociology, anthropology and history. Due to the development of public education, the widespread presence of mass media, and as the result, people becoming literate, local languages and dialects are replaced with official languages. Ethnic linguistics provides the opportunity for reconstructing the unwritten history based on the existing data. Developing the studies about, and writing and codifying dialects in order to preserve cultural identity and historical heritage, and to clarify the ambiguous points about the ancient languages of Iran and discovering their grammatical and lexical structure, alongside with the culture of people speaking those languages, is the key objective of dialectology, and this study is to serve this objective.

### The Lingual Descent of the Old Language of the Village of Vafs

The region of Vafs, in local dialect "Veous", is one of the sub regions of the city of Arak, in Markazi Province of Iran, which is 5 kilometers from Park to the west, and 16 kilometers from Komijan to the north, located in "Kuh Sefid". "Chehraqaan" /čeræqān/, "Gurchan" /qurčān/ and "Park" /færk/ are among the villages speaking the dialect of this region.

Most linguists believe that the dialect of Vafs is rooted back in the main branch of Indo-European – Indo-Iranian – Northwest Iranian – Central Iranian (Schmitt, 1983, 313). Stillo has stated that "the exact linguistic chain of Vafsi is under question; while it is classified as one of the sub branches of Tatic, particularly southern Tatic, some researchers regard Vafsi as one of the accent of the Central Plateau. Pierre Locoke believes that Vafsi and other dialects of the region of Tafresh have some grammatical features in common with the accent of the Central Plateau. He also thinks that this group has a richer

vocabulary than that of Tatic. Vafsi also has some features close to that of Kurdish (12, Stillo).

Azeri Turkish and modern Persian are also spoken in this village. Azeri-speaking residents of Vafs call this village "Bouws" and call its dialect "tāt dil" (Moqadam, 10, 1949). The dialects related to this accent are Alviri, Vidari, Ashtiani and Rudbari. The residents of Vafs and the three villages of Chehraqaan, Gurchan and Park speak Vafsi.

### Nominal Phrases

Nouns in Vafsi dialect are categorized into "masculine" and "feminine" based on gender, "singular" and "plural" based on count, and "direct" and "indirect", based on the mood. Plural nouns are used in the same for both genders and adjectives have feminine and masculine terminals.

Tables 1 and 2 represent noun and adjective suffixes, categorized based on gender, count and mood.

### Gender

Feminine nouns: feminine nouns in this dialect are divided into two subcategories:

1. Nouns ending to "æ", e.g. kúgæ (cat), čúæ (wood)
2. Nouns ending to "é", e.g. keljé (girl), āhré (mill)

Masculine nouns: these nouns are divided into three subcategories:

1. Nouns ending to a consonant, e.g. zævin (earth), ayr (fire)
2. Nouns ending to diphthongs, e.g. hæssew (account)
3. Nouns ending to vowels, e.g. lā zæ (boy), juānxau (blanket), āmu (uncle), duiā (human), šo (night)

### Adjectives:

Adjectives are of two types in Vafsi dialect:

1. Adjectives which follow the main noun with a particular bonding single word and show the accordance of gender with the noun:

Feminine: mišæ isbiæ (white sheep), æhāmmūæ nāzók (fine giveh (a kind of hand-made shoes))

Masculine: penjæ xunin (bloody hand), bawæ pir (old father)

There is another combination typical to this dialect, in which a single word joins the main noun to

the following adjective. This one is different from persian possessive.

2. Adjectives which precede the noun and do not change based on count or gender, which include adjectives of referral, question, finite ordinal numbers showing physical or abstract situation, adjectives used as curses, etc.: ðhre seyyómi (the third mill), zerí ðhre (the mill on the down), kæzan (which one), hævin (this one), læ:næti lazæ (damn boy)

Table 1: Noun suffixes

Gender	Masculine								Feminine			
	to a consonant		to -a		to -æ		to -u		to-æ		to-é	
Noun ending	Horse		Boy		Dog		Child		Cat		Girl	
Count and mood												
Direct singular	Ø	æsb	Ø	Zawá	Ø	æsbæ	Ø	zarru	Ø	kúg-æ	Ø	kelj-e
Indirect singular	-i	æSb-i	-y	Zawá-y	-y	æSbé-y	Øy	zarru-Ø ,zarru-y	-é	kug-e	-i	kelj-i
Direct plural	-e	æsb-e	-y -e	Zawá- y-e	-e	æsb-i-e	-e	zarrú-e	-é	kúg-e	-e	kelj-e
Indirect plural	-án	æsb- án	-án	Zawa-y	-án	æSbi-án	-án	zarru-án	-án	kug- án	-án	kelj-án

Table 2: Adjective suffixes )mæzæn(Big:

Gender	Masculine		Feminine	
Count and mood				
Direct singular	Ø	mæzæn	-æ	mæzæn-æ
Indirect singular	-i	Mæzæn-i	-é	mæzæn-é
Direct plural	-e	mæzæ-e	-e	mæzæn-e
Indirect plural	-án	Mæzæ-án	-án	mæzæn-án

### Omission and Inversion in Vafsi Dialect and Its Accordance to Other Iranian Languages

As mentioned before: "In rural areas of central and western Iran, and also in Azerbaijan, there are some separate islands of northwest dialects which are the remains of dialect which were once prevalent in a wide area of this region, and have lasted to date ... namely, the dialects of Vafs, Ashtiyani, Tafresh, and the area between Hamedan and Saveh." (Aranski, 1999, 144)

The changes which happen to the speech sounds during the evolution of each language follow a rule, and if languages of the same family follow the same rule, there should be accordance between them, in

terms of their speech sounds. This systematic sound accordance is seen between all Iranian languages. The differences between the speech sounds which has separated northwest Iranian accents from southwest Iranian accent since ancient times, is distinctly seen in Iranian languages." (Aranski, 2000, 331)

To show the relationship between Vafsi and ancient and medial languages of Iran, the historical process of some words left from these times is presented here.

\* The accordance between "z" from northwest and "d" from southwest, which reflects the difference between "z" in Avestaian and "d" in Ancient Persian, or "z" in Parti and "d" in median Persian.

English	Avestaian	Parti	Median Persian	Southwest	Northwest	Ashtiyani	Amerehi	Kurdish	Vafsi
Groom	zāmātar	zumā	dāmāt	tat.dumbor	tal.zomo	zāmā	zumā	zāmā	<b>Zāvva</b>
Know	zān	zān	dān	tat.dunstan	tal.zənə	zānān	bazu	zān	<b>zānān</b>
Heart	zərəd	zird	dil	taj.dil	gu.ziL	del	dil	zil	<b>Del</b>

\* Vafsi and the central dialects, in addition to having a relationship with northwest languages, are close to southwest languages too: the reflection of "ur" in Avestaian and "ur" in ancient Persian, in the form of "hr" and "si" in southwest and medial Persian accents, and also the reflection "j" in ancient Persian and "z" in Parti and medial Persian, in northwest and southwest accents:



English	Avestaiaian	Parti	Median Persian	Southwest	Northwest	Ashtiyani	Amerehi	Kurdish	Vafsi
Three	θri	hrē	se	taj.se	tal.hai	se	se	se	<b>Se</b>
Boy	puθrā	puhr	pus	taj.pisar	las.pur	pūr	pur	pur	<b>Lāzā</b>
Woman	janay	zan	zan	tat.zan	tal.žen	zenni	zena	žin	<b>Zene</b>
Hit	jan	žan	zan	taj.zan	tal.žae	-	-	kotain	<b>Ajjané</b> (میزند)

\* The accordance in referral pronouns which are rooted in the referral pronoun of ancient Iranian of (hauv):

English	Avestaiaian	Parti	Median Persian	Southwest	Northwest	Ashtiyani	Amerehi	Kurdish	Vafsi
This	ima	im	ēn	taj.in	tal.em	yān	yo	ya	<b>In</b>
That	ahmāi	hō	ān	taj.on	tal.āv	ān	enovv	āw	<b>ān</b>

\* There are some differences in the vocabulary of the current languages of the west of Iran, which are rooted in the accordance of "važ" in northwest language (Parti) with "gōβ" in southwest language (medial Persian). There root "wāč" does not exist in southwest accents. The Institute of Linguistics has derived the word "vak" from a Persian root, while Persian has not kept this word during its historical process. Northwest languages and Kurdish has kept "ž", e.g. "bež" which is rooted in "vāž", or the word "zæn" which is made with "ž" in all dialects of the northwest of Iran, and is pronounced as "z" in Persian, or in the verb "arvazom" (I make) which leads Vafsi far from Tati and makes it closer to the central dialect.

English	Avestaiaian	Parti	Median Persian	Southwest	Northwest	Ashtiyani	Amerehi	Kurdish	Vafsi
Say	mrav	vāž	goβ	taj.gūy	tal.vote	vottan	boeā	vāž	<b>Vāttan</b>

\* A comparison between some words in Avestaiaian and Vafsi

	wind	door	I	hand	male	mountain	brother	arm	water
Avestaiaian	vāta	dvar	azem	zasta	nar	gairi	brātar	bāzu	āp
<b>Vafsi</b>	<b>vā</b>	<b>bar</b>	<b>az</b>	<b>dast</b>	<b>nerē</b>	<b>ku</b>	<b>berā</b>	<b>bāzu</b>	<b>Auw</b>

\* A comparison between some words in the languages of the east of Iran and the west of Iran

English	Eastern Iranian	Western Iranian	Vafsi
partridge	as.kāf	tat.zerej/zāš	<b>Kōuk</b>
cow	as.yog	tat.gou	<b>Gā</b>
dog	as.kudz	tal.səpa	<b>Asba</b>
fish	as.kāf	taj.mohi	<b>Muhi</b>
ear	as.yos	tat.guš	<b>Gūš</b>
eye	išk.com	tal.čaš	<b>čē</b>
four	af.curpar	taj.čahar	<b>čahār</b>
five	af.pindzə	kr.penj	<b>penj</b>
seven	as.aud	tat.hāft/kr.haft	<b>Haft</b>
leather	af.cermən	kr.č'arm	<b>čarm</b>
To be	vx.vit	tal.be/kr.bu	<b>Biyan</b>
brother	as.ārvād	tal.boa/kr.bērā	<b>Bērā</b>

### Some Examples of the inversion of consonants in Vafsi

#### Inversion of "x" to "h"

Persian	xurd kardan	xis xurdan	xešt	āhur
Vafsi	hurđ kardan	his hurđan	hešt	āhura

\* The inversion of "x" before "t" and "f" before "t" into "t" can be seen in some dialect of Iran, especially in verb declensions. Also, in some Vafsi words "x" is omitted.

Persian	mextan	sāxtan	suxtan	furuxtān	gorixtan	poxtan	toxm	talx	surx	kulux
Vafsi	mettan	sāttan	suttan	ruttan	verittan	pettan	tum	tal	sur	Kulu

\* one of the main features of Vafsi, as compared to other dialect in Persian, is using "v" or "vv" instead of "m" in old Iranian, which is one of the three features "McKenzie" introduced for the languages which are related to Kurdish:

Persian	mān (possessive pronoun)	xamir	vabā	namad	šumā	zamin	āsemān	gandom	deim	kamān
Vafsi	vān	haviz	vāvvā	neva	suvān	zavin	āsuvān	gendov	div	Kavān

\* Also, the inversion of "f", "l" and "g" into "x", and the inversion of "k" into "x" under the impact of "t", can be observed in some words in this dialect. Historically, all these processes are rooted back in Old Iranian. At synchronic level, "xt" is inverted into "z", which is called "palatalization", and is one of the requisite features of Indo-Iranian languages and one of the most important keys to identify a language as related to Iranian languages.

This can be seen through an example: in the word "čitāb" (book) in Turkish (Azeri), "k" is inverted into "č", hence, it can be concluded that the residents of this region were previously speaking Iranian. "č" of Ancient Iranian has been inverted into "ž" or "z" in medial era. Languages having "z" should belong to the southwest. In Vafsi, either there has been a second inversion under the impact of Persian, in which the "ž" from the northwest has been Persianized into "z", e.g. tājeme<tāzem (tāxtan: ride), or there might have been an intra-lingual inversion, since it is more difficult to pronounce "j" as compared to "z".

saxt	doxtar	yaqe	xāle	fešar
sākta>sāxt	daukta>doxta	yāxa	lālla	Xošar

\* Also, the inversion of "g" to "š", "g" to "v", "š" and "s" to "č", "č" to "z", and "j" to "y" or "vi"

jušāndan / jo	zardčube	gorg	angošt	give	miraft
višāndan / yav	zardzuvā	varg	angest	šive	basse>ače

\* The inversion of "b" to "v" or "f", "f" to "v", "k" to "g", and "j" to "z", from Persian into Vafsi

sargije	tiq	qalbār	kalāq	banafš	hefdah	sebil	barf	abr	bare
sargize	tik	kalbā	gālaya	banuš	hevdah	sefil	farfa	avr	Varah

\* Some examples of the omission of (f, d, v, h, k, i, γ), and also the replacement of sounds in Vafsi

tubre	gofl	dalv	xāk	šaftālu	dūd	gāv	dahān	divār	čerāg
torba	golf	dol	xā	eštālu	dū	gā	dān	duār	čerā

One of the most important confirmed theories about Indo-European linguistics is the theory of "Wave promotion". Basically, Iranian languages are formed in a wave form. As seen in the parameters mentioned above, Vafsi has borrowed items from many languages, and it cannot be defined which sub-language it belongs to for sure; however, based on the wave theory and the form of the promotion of this dialect over a geographical district, it can be seen that Vafsi has been promoted to Ashtiyan, then to Hamedan toward the north (there should have been some dialect to connect Vafsi to Taleshi, however, Turkish has separated them), and then towards Arak, Isfahan, Yazd, etc, and as it has been promoted towards south, it has changed into another language (Persian) and has lost its (Maadi) features (two geographical districts have been defined as related to this promotion: the triangle of Rey- Isfahan-Hamedan = The Great Maad, and the district of Azerbaijan and the north = The Small Maad). This process can be

historically explained: at the era of Old Iran and the immigration of Partis from Khorasan, Maadi dialect begins to form in north and promotes from Azerbaijan and Tabriz, which is the central area speaking this dialect, towards Hamedan. There it changes into Hamedani dialect, and from there, it promotes towards Isfahan, while being subjected to more changes due to the wave promotion, and it changes into the Yazdi dialect, and from there it is promoted further to change into Persian. As Iranian immigrated to different places and were blended with Partis, a diversity starts to grow inside the languages of Maads. In Ancient Persian which is the oldest form of Persian, there are some adoptions from Maadi, e.g. there should have been (bodorg = big), which is (bozorg<), or (demestān<zemestān). These chains are broken during the time, Persian rejects some dialects, and one Iranian dialect omits another.

Nowadays, the social class component of language has dominated other components, and all

dialects are at the danger of being changed into the standard language used in mass media, which makes it hard to reconstruct languages.

### Economic Resources and Language

Languages reflect social processes. We always tend to emphasize on the motives with recognized roles in our lives and in satisfying our basic needs. This rule is called "selective attention" which holds true for languages too. "Those thing of no particular importance for the members of a particular society, may have no specific names or be classified under a general name. However, basic issues may have not only one name, but several names, in order to show the delicate differences between them that the people speaking that language understand and feel the need for them to be separated. These linguistic classifications are one of the main issues emphasized by lingo-anthropologists. They call a group of related issues in a language or the terms of a particular subject, such as relationship, diseases, working tools, animals, plants, etc., "Connotative Territory". The connotative structure of a society can be tracked down through studying connotative territories. This connotative structure not only includes common interests of a society, but also shows how these interests have structured the mental framework of the people of that society (Bates, 456).

By studying connotative fields of Vafsi, various words related to farming tools reveal that this language community has a long history of farming behind. Different words for "wheat" in different phases of growth, different uses of a plant in growing phases, different names for mills and its parts, names for different plants alongside with their healing and medical properties, different storage rooms for different products which were of great importance for the survival of these people, different tamed and wild animals used for farming and plowing, the names of pest and insect which killed pests, sowing and harvesting methods, the veneration of birth, growth and harvest seasons, lingual taboos related to farming, beliefs, sayings, songs with this economy as their central themes, etc, all can only be seen in the memories of old men and women and their nostalgic tales.

### Conclusion

Some phonetic specifications of Vafsi dialect and the reasons to relate this dialect to the languages of ancient and medial Iran are as following:

1. Vafsi nouns are of the two genders of masculine and feminine, two counts of singular and plural, and two moods of direct and indirect. Plural forms are the same for the two genders, and the bases

of adjectives are differentiated into masculine and feminine (Stilo, 223).

2. There is often a particle after a noun, e.g. "čāla da" (in a hole), "s daēlē" (in his heart)

3. Closing the last syllable of the words in "a" and "e", while in modern Persian they are closed in consonants, e.g. "detta" (daughter)

4. The inversion of "f" followed by a "t" into "t", mostly in verbs, e.g. " rettan" (pour), "ruttan" (sell)

5. The inversion of "m" in ancient Persian into "v" and "vv" ("m" at the beginning of a word is usually maintained the same).

6. There are two symbols for tenses: "at" for continuous tenses and "ba" for non-continuous tenses

7. The addition of "s" to the nouns, as for the third person pronoun hidden in the verb in Modern Persian, e.g. "āgeles darda"

8. The inversion of "x" followed by a "t" into "t", mostly in verbs, e.g. " rettan" (pour), "ruttan" (sell)

9. Using aspirate sounds of "h " and "?" both in originally Arabic words and Persian words, e.g. āhra, hoqqa, ħaris, s? ūn, ? sb (Kia, 1956).

10. One of the main aspects of Vafsi grammar is the signs and the moods of objects and subject and their accordance pattern, particularly in past tenses. In Stilo's idea, is some minor changes in auxiliary ergative old languages in order to have more complex uses in modern languages. This kind of change in transitive-accusative past tenses can show that Vafsi has lost its ability to differentiate between subject and object (as for Persian) and is in its way towards causative-nominative for all tenses.

Being ergative is one of the main features of ancient languages, like African and Indian languages. This feature is seen in also in the languages of Raji, Khor and Biabanak, and Kurdish. This feature confirms the grammatical relationship between Vafsi and ancient languages. Ergative structure of this language, particular verb prefixes and suffixes, etc, shows its relationship with other Indo-European languages.

11. Sound system accordance between Vafsi and the languages of the northwest of Iran proves this dialect to be the chain connecting modern Persian to medial Persian, Parti, ancient Persian, and at last, to Avestaian.

12. The structure of some words, possessives and genitives, and particles show the relationship between this dialect and Maadi and Avestaian languages.

13. Some primitive handmade tools, potteries, and buildings made in the architecture style of Achaemenid have been discovered in this area, and regarding that Vafs is close to Ecbatana (the capital

of Achaemenids), this is now regarded more probable that Vafs had once been one of the key cities of Achaemenids.

14. By studying old plays, beliefs and sayings of these people, it is revealed how old this culture is, and that this culture has been passed from Aryan ancestors through generations.

15. The etymology of some words of this language confirms that this tribe have had a community life in old eras.

#### References

1. Oranski, "The Introduction to Persian Lexicology", Trans. Keshavarz, 2000.
2. Oranski, "The languages of Iran", Trans. Sadiqi, Tehran: Soxan, 1999.
3. Bates, Daniel. "Cultural Anthropology", Trans. Solasi. Tehran: Scientific, 2006.
4. Barikloo, Hossein-Ali, "Natural, Economic and Human Geography of Vafs", Thesis, 1994.
5. Xalaf-e-Tabrizi, Muhammad-Hussein, "Burhan Qati", Tehran, Amir-Kabir, 1983.
6. Wikipedia
7. Dehgan, Ibrahim. "History of Arak", 1963.
8. "The dictionary of Iran Geography", Geographic Section of the Army, 1949.
9. Kia, "Iranika", 1956.
10. Moein, Muhammad, "Persian Dictionary", Tehran, Amir-Kabir, 1963.
11. Aflakian Magazine, Vafs, 1991.
12. Moqadam, Muhammad, "The Dialect of Vafs, Ashtyian and Tafresh", Irankadeh magazine, No.3, 1949.
13. Moosavi-Mirak, Fatemeh, "Comparative-Historic Linguistics of Vafs", Faculty of Oriental Studies, the State University of Armenia, 2006.
14. Moosavi-Mirak, Fatemeh, "Ethnic Anthropology of Vafs", 2005.
15. Szemerényi, Oswald, "Introduction to Indo-European linguistics", 1990.
16. Stilo, Donald, "Vafsi folk tales": Wiesbaden, 2004.
17. Schmitt, Rüdiger. "compendium linguarum Iranicarum": Wiesbaden, 1989.
18. Hofman karl ... "Hand buch der orientalistik": L eiden-köln, 1958.

/tag/ Taleshi

/taj/: Tajiki

/kr/: Kurdish

/gur/: Gurani

/las/: Lasgerdi

/vx/: Vaxani

>: After a word shows its evolution and next developed form

<: After a word shows its root.

-: On the vowels on which the accent falls

\_: separates the syllables of a world

/: represents "and", "or"

=: represents equivalence and phonetic equivalence

ε =?

ح =h

ġ = γ

10/6/2012

#### Abbreviations:

/as/: Asi

/af/: Afqani

/išk/: Ishkashmi

/tat/: Tati

## Study of Cognitive Functions and Cerebral Blood Flow in Elderly

Afaf A. Hemeda, Dalia R. Abdel-Rahman, Mohamed Naguib Abdalla, Ahmed A. El-Naggar and Dina M. Riad

Internal Medicine Department, Faculty of Medicine, Cairo University, Cairo, Egypt  
[mnwif@gmail.com](mailto:mnwif@gmail.com)

**Abstract: Background and Aim:** Little information is available about cognitive functions and changes in cerebral blood flow in elderly people with or without cognitive dysfunction, despite the great influence of this problem on patient, family and society. Our study aimed at evaluating the cerebral blood flow (CBF) in elderly patient with cognitive dysfunction, either primary (Alzheimer Dementia), or secondary (vascular Dementia). **Methods:** assessment of the cognitive function and CBF of a group of 20 patients aged > 65 years old, 10 patients with vascular dementia while the other 10 patients with Alzheimer dementia and the results compared to a group of healthy volunteers. **Results:** all patients had significantly decreased Mini Mental State Examination (MMSE), Set test scores compared to that of healthy volunteers while there is significant difference regarding the Geriatric Depression Scale (GDS). Patients with vascular dementia had significantly diminished CBF compared to the healthy volunteers which doesn't go for those with Alzheimer dementia. There is significant positive relationship between MMSE scores and CBF in patients with vascular dementia ( $r=0.77$ ,  $p\text{-value}=0.009$ ). Patients with vascular dementia had significantly high percent of hypertension and diabetes than do Alzheimer group. **Conclusion:** Brain ischemia was suggested to be the main factor responsible for decline of cognitive functions. The role of cerebral ischemia in Alzheimer dementia was insignificant. Cardiovascular risk factors are more related to vascular dementia. [Afaf A. Hemeda, Dalia R. Abdel-Rahman, Mohamed Naguib Abdalla, Ahmed A. El-Naggar and Dina M. Riad. **Study of Cognitive Functions and Cerebral Blood Flow in Elderly.** *Life Sci J* 2012;9(4):1704-1707] (ISSN:1097-8135). <http://www.lifesciencesite.com>. 261

**Keywords:** MMSE, CBF, Set test, vascular dementia, Alzheimer dementia

### 1. Introduction

Mental dysfunction usually leads to impairment in the quality of life, increase dependence, social and financial burden and caregiver stress, it is most of the time more hazardous than the original co-morbidity.<sup>1</sup> So, early detection, intervention and prevention can help to relieve both personal and community burden of this problem.

The main objective of the present study is to evaluate cerebral blood flow (CBF) in elderly patient with cognitive dysfunction, either primary (Alzheimer Dementia), or secondary (vascular Dementia).

### 2. Patients and methods:

After approval of the institutional ethical committee 10 healthy volunteers (group I) and 20 patients aged  $\geq 65$  years old attending to Kasr Al-Aini outpatient clinic were included in our study, patients with end organ disease, anemia or endocrinal disease (other than DM) were excluded from our study. The studied group of patients were categorized into two groups, 10 patients with vascular dementia (group II), and 10 patients with Alzheimer dementia (group III). All the studied groups were subjected to Assessment of daily living activities, evaluation of psychic status using geriatric depression scale, detailed clinical examination, biological tests, and assessment of cognitive functions by MMSE, Set test. Non-contrast

enhanced computed tomography (CT scan) of the brain, Duplex ultrasonography using HDI-5000 Doppler machine with high frequency transducer 7-10 MHz of extracranial internal carotid artery and vertebral artery was performed to measure cerebral blood flow using timed average velocity and diameter of vessels studied.

### Interpretation of MMSE:

A total maximal score on the MMSE is 30 points. A score of less than 24 points is suggestive of dementia. Using a cutoff of 24 points, the MMSE had a sensitivity of 87% and a specificity of 82% in a large population based sample<sup>2</sup>

However, the test is not sensitive for mild dementia, and scores may be influenced by education, as well as language, motor, and visual impairments<sup>3</sup>

### Interpretation of Set test:

The Set test is referred to also as the category Fluency test, is particularly helpful in assessing patients with low formal education levels that the MMSE cannot reliably be used to test.

To administer the Set test, the older person is asked to name as many items as they can in each focus Sets are categories. The four sets are (fruits, animals, colors and towns). The test examines a number of cognitive domains including language, executive functions and memory. The test best score

is 10 in each set, for a maximum score of 40. A Set test score less than 15 is considered abnormal.<sup>4</sup>

### Statistical analysis:

Statistical analysis was done using Minitab, version 16. Descriptive statistics were expressed as mean  $\pm$  standard deviation for quantitative variables and frequency  $\pm$  percent for qualitative variables. The Student's t-test and Mann-Whitney test were used to compare between the quantitative variable while the chi-square test was used to compare between the qualitative variable in the study group. *P*-value was considered significant if less than 0.05.

### 3. Results:

Characteristics of participants and their laboratory data are represented in table (1). The results of our study showed that there is no statistically significant difference between the three studied groups regarding the mean triglycerides (TG) levels or the percent of ischemic heart disease patients, while the vascular dementia group showed a statistically significant increase in the percent of hypertensive and diabetic patients than do other studied groups, while patients of Alzheimer dementia group have statistically significant elevated levels of total cholesterol than do patients of other groups.

By assessing the cognitive function for all studied groups, it was reported that patients of both vascular and Alzheimer dementia groups have significantly decreased mean MMSE scores than do those of the control group, the same goes for mean set test scores and mean MMSE + Set test scores, while there is no statistically significant difference between the studied groups regarding the mean GDS. Regarding the mean total cerebral blood flow it was reported that patients of Vascular dementia group have significantly decreased levels than that of the control group and this doesn't go with patients of Alzheimer dementia group.

There is a statistically significant positive relationship detected between MMSE and CBF in vascular dementia group with  $r = 0.77$  and  $p$ -value = 0.009, while this relationship becomes statistically insignificant weak negative relationship in Alzheimer dementia group ( $r = -0.09$  and  $p$ -value = 0.8). Also a statistically significant positive relationship detected between the mean CBF levels and the scores of set test + MMSE test in vascular dementia group with  $r=0.83$  and  $p$ -value=0.003.

Regarding the mean serum blood glucose levels, it showed a statistically insignificant negative relationship with the mean MMSE scores with  $r = -0.37$  and  $p$ -value = 0.29 in vascular dementia group, while this relationship becomes statistically insignificant positive with  $r=0.31$  and  $p$ -value=0.39 in

Alzheimer dementia group. It doesn't show any statistically significant relationship with the mean CBF levels in both vascular and Alzheimer dementia groups.

Comparison of laboratory findings, cognitive functions, cerebral blood flow, imaging findings of three groups

### 4. Discussion:

Cerebral blood flow (CBF), is the blood supply to the brain in a given time<sup>4</sup>. In our studied group it was reported that Mean total CBF in vascular dementia group was significantly lower than that of healthy volunteers group. This finding supports the idea that dementia in those patients is explained by loss of part of brain tissue, either single large part or multiple small parts. On the other hand the mean total CBF in Alzheimer group was insignificantly different from that of the healthy volunteers group and this comes in concordance with the suggestion that the role of ischemia in the development of Alzheimer's disease is not an important etiological factor. Also we found no major vessel disease in Alzheimer group with controversy to vascular dementia which shows diminution of CBF and major vessels affection in most of patients. This doesn't go with what was concluded with other studies<sup>5-6</sup>

In our study having a considerable percent of patients with hypertension, diabetes mellitus and ischemic heart disease in patients with vascular ischemia suggests that cardiovascular risk factors played an important role in development of vascular dementia where it is known that patients with small vessel and large artery disease (SLAD) had poorer cognitive and functional outcomes when compared to patients without SLAD<sup>7</sup>. While having significantly higher values of serum cholesterol in patients with Alzheimer dementia suggest that the high cholesterol level was the only cardiovascular risk factor in Alzheimer dementia group, which doesn't go with other studies<sup>8</sup>. Other studies had studied the relationship between vascular comorbidity and Alzheimer dementia, where many individuals with Alzheimer dementia, especially those beyond 85 years of age, show significant vascular comorbidity, to the extent that they are more accurately characterized as having mixed vascular- Alzheimer dementia.<sup>9</sup> In one large autopsy series, 'pure' vascular dementia was seen in 9.4% of 900 individuals with dementia, but in only 2.9% of patients with the clinical diagnosis of probable or possible Alzheimer dementia.<sup>11</sup> Vascular disease has also been reported to accelerate atrophy and result in white matter abnormalities, asymptomatic infarct, inflammation and reduced glucose metabolism, cerebral blood flow and vascular density.<sup>12</sup> While other studies reported

that determining the neurobehavioral and neuroimaging correlates of ischemic brain lesions occurring in the context of significant Alzheimer dementia alterations can be a very difficult task, and the usefulness of the traditional strict differentiation between Alzheimer dementia and vascular dementia has been challenged.<sup>14</sup> Even though a mixed etiology is likely to be more common than either pure Alzheimer dementia or vascular dementia among older patients, there are no current clinical criteria for ante-mortem diagnosis of mixed dementia.<sup>11</sup> Pathological changes have been associated with not only dementia of the vascular type but also Alzheimer disease.<sup>15-16</sup> In conclusion: Tissue infarction was suggested to be the main factor responsible for

decline of cognitive functions in vascular group. The role of cerebral ischemia in Alzheimer dementia group was mostly insignificant. Cardiovascular risk factors were more related in vascular dementia group than Alzheimer dementia and this support the idea that correction of cerebrovascular risk factors is essential to prevent secondary dementia in these groups of patients. Further large scale study is recommended to combine both duplex ultrasound to measure CBF in major cerebral vessels and SPECT to evaluate micro vascular disease and neuron metabolism, as this will be more informative about effective CBF. Data obtained can be analyzed in comparison to MRI angiography that is considered an accurate tool for CBF measurement.

**Table (1): laboratory findings, cognitive functions, cerebral blood flow, imaging findings of three groups:**

	Group I	Group II	Group III
Age Mean±SD	67.8±3.85	71.2±6.58	71.4±5.02
Min/Max	65-77	65-85	65-79
Sex Male/Female	8/2	4/6	4/6
HTN	0 (0%)	7 (70%)	2 (20%)
DM	0 (0%)	6 (60%)	1 (10%)
IHD	0 (0%)	4 (40%)	1 (10%)
HB (gm %)	13.54 ± 1.51	12.77 ± 1.90	12.23 ± 1.6
GLU(mg/dl)	89.4 ± 13.18	147.5 ± 74.96	95.4 ± 20.24
AST (IU/dl)	24.9 ± 7.49	29.7 ± 17.15	29.2 ± 14.85
ALT(IU/dl)	31.8 ± 20.25	19.16 ± 11.08	24.9 ± 14.91
BIL-T(mg/dl)	0.709 ± 0.29	0.56 ± 0.38	0.592 ± 0.33
GGT(U/L)	63.4 ± 24.80	32.9 ± 33.27	26 ± 10.27
TP(g/dl)	7.35 ± 0.68	7.09 ± 1.33	6.63 ± 0.50
ALB(g/dl)	4.05 ± 0.26	3.34 ± 0.77	3.49 ± 0.41
ALP(U/L)	81.5 ± 19.52	75.1 ± 15.01	86.1 ± 31.34
UREA(mg/dl)	35.3 ± 6.67	46.9 ± 18.28	51.4 ± 30.39
CRE(mg/dl)	1.04 ± 0.23	1.038 ± 0.32	1.005 ± 0.22
Total CHOL(mg/dl)	179.6 ± 33.07	168.7 ± 58.03	235.8 ± 72.74
TG(mg/dl)	145.7 ± 39.92	95.4 ± 36.62	96 ± 26.35
LDH	249.4 ± 48.10	290 ± 142.63	342.3 ± 162.6
CA(mg/dl)	8.81 ± 0.4	8.22 ± 0.85	8.9 ± 0.75
PHOS(mg/dl)	3.78 ± 0.53	3.76 ± 0.55	3.54 ± 0.55
Na(meq/L)	139.1 ± 3.84	136.7 ± 4.42	141.7 ± 4.14
K(meq/L)	4.28 ± 0.49	4.25 ± 0.57	4.29 ± 0.62
<b>Assessment of cognitive functions</b>			
MMSE	26.6 ± 3.66	9.6 ± 4.55	10.1 ± 2.47
Geriatric Depression Scale	11.9 ± 10.42	11.6 ± 9.77	9.5 ± 5.91
Set test	39.4 ± 0.97	9.2 ± 6.18	12.2 ± 1.99
MMSE+ Set test	66 ± 4.52	18.8 ± 9.78	22.3 ± 3.62
<b>Assessment of cerebral blood flow</b>			
RT ICA(ml/min)	255.05 ± 39.36	263.06 ± 117.79	---
LT ICA(ml/min)	199.48 ± 46.10	176.196 ± 145.03	---
Total internal carotid flow(ml/min)	454.53 ± 79.08	439.26 ± 123.48	---
LT VA(ml/min)	83.81 ± 33.22	69.766 ± 50.04	---
RT VA(ml/min)	88.59 ± 34.95	52.606 ± 24.29	---
Total vertebral flow(ml/min)	172.40 ± 63.17	122.37 ± 64.97	---
Total CBF(ml/min)	628.83 ± 87.3	520.88 ± 132.22	579.17 ± 72.84
<b>CT brain findings:</b>			
CT Brain showing Infarction	0	10 (100%)	0
CT Brain with involuntional Changes	0	0	6 (60%)
Normal CT	10(100%)	0	4(40)

**Table (2): Comparison of the clinical and investigational techniques in studied groups:**

	Group I	Group II	Group III	p-value	
				Group I vs. II	Group I vs. III
HTN	0 (0%)	7 (70%)	2 (20%)	0.003	0.474
DM	0 (0%)	6 (60%)	1 (10%)	0.011	1
IHD	0 (0%)	4 (40%)	1 (10%)	0.087	1
Total CHOL(mg/dl)	179.6 ± 33.07	168.7 ± 58.03	235.8 ± 72.74	0.336	0.008
TG(mg/dl)	145.7 ± 39.92	95.4 ± 36.62	96 ± 26.35	0.78	0.89
<b>Assessment of cognitive functions</b>					
MMSE	26.6 ± 3.66	9.6 ± 4.55	10.1 ± 2.47	0.000	0.000
Geriatric Depression Scale	11.9 ± 10.42	11.6 ± 9.77	9.5 ± 5.91	0.94	0.53
Set test	39.4 ± 0.97	9.2 ± 6.18	12.2 ± 1.99	0.000	0.000
MMSE+ Set test	66 ± 4.52	18.8 ± 9.78	22.3 ± 3.62	0.000	0.000
<b>Assessment of cerebral blood flow</b>					
Total CBF(ml/min)	628.83 ± 87.3	520.88 ± 132.22	579.17 ± 72.84	0.047	0.185

**References**

- Laura N.G., David L.R., Louis D. B., *et al.* (2005): Caregiver Appraisals of Functional Dependence in Individuals with Dementia and Associated Caregiver Upset, Psychometric Properties of a New Scale and Response Patterns by Caregiver and Care Recipient Characteristics. *J of Aging and Health* ; vol. 17 no. 2 :148-171
- Crum RM., Anthony JC., Bassett SS., *et al.* (1993): Population-based norms for the Mini-Mental State Examination by age and educational level. *JAMA*; 269:2386.
- Freidl W., Schmidt R., Strongegger WJ., *et al.* (1996): Mini-Mental State Examination: Influence of sociodemographic, environmental and behavioral factors and vascular risk factors. *J Clin Epidemiol*; 49:73.
- Richard J.H.(2007): A case approach; *Primary care geriatrics 5<sup>th</sup> edition*, p 925
- Tolias C. and Sgouros S. (2006): "Initial Evaluation and Management of CNS Injury." *Emedicine.com*. Accessed January 4, (2007). *A Pediatric Vade-Mecum*, 14th Edition. Arnold, London, pp. 169-173.
- Peter B., Satoshi M., Christine H., *et al.* (1997) : Regional Blood Flow Abnormality. *J Nuclear Medicine*: Vol. 38 No. 7:1095-1101
- Schreiber S. J., Doepf F., Spruth E., *et al.* (2004): Ultrasonographic measurement of cerebral blood flow, cerebral circulation time and cerebral blood volume in vascular and Alzheimer's dementia. *Journal of Neurology*. Vol 252, (10): 1171-1177.
- Man BL, Fu YP, Wong A, Chan YY, Lam W, Hui AC, Leung WH, Mok V, Wong KS. Cognitive and functional impairments in ischemic stroke patients with concurrent small vessel and large artery disease. *Clin Neurol Neurosurg*. 2011;113(8):612-6.
- J. A. Luchsinger, C. Reitz, L. S. Honig, M. X. Tang, Steven Shea, R. Mayeux. Aggregation of vascular risk factors and risk of incident Alzheimer disease. *Neurology* J.10.1212/01.wnl.0000172914.08967.dc *Neurology* August 23, 2005 vol. 65 no. 4 545-551
- Langa KM., Foster NL., Larson EB., *et al* (2004): Mixed dementia: emerging concepts and therapeutic implications. *JAMA*; 292: 2901-2908
- Jellinger KA. (2002): The pathology of ischemic-vascular dementia: an update. *J Neurol Sci*; 203-204: 153-157.
- Nilsson PM. (2008): Early vascular aging (EVA): consequences and prevention. *Vasc Health Risk Manag*; 4:547-552.
- Gold G., Giannakopoulos P., and Bouras C. (1998): Re-evaluating the role of vascular changes in the differential diagnosis of Alzheimer's disease and vascular dementia. *Eur Neurol*; 40: 121-129
- O'Brien JT., Erkinjuntti T., Reisberg B., *et al.* (2003): Vascular cognitive impairment. *Lancet Neurol*; 2: 89-98
- Rockwood K., Macknight C., Wentzel C., *et al.* (2000): The diagnosis of "mixed" dementia in the Consortium for the Investigation of Vascular Impairment of Cognition (CIVIC). *Ann N Y Acad Sci*, 903:522-528.
- Jellinger KA. (2006): Clinicopathological analysis of dementia disorders in the elderly—an update. *J Alzheimers Dis*; 9:61-70

10/5/2012



## An Examination on the Effect of the Performance Audit Implementation on the Improvement of the Productivity of Public Sector Management Systems in Iran (A Case Study in Supreme Audit Court)

Sirous Fattahi<sup>1</sup>, Dr. Seyed Ali Vaez<sup>2</sup>, Dr. Ali Hossein Hosseinzadeh<sup>3</sup>

<sup>1</sup>Persian Gulf International Educational Branch-Islamic Azad University- Khorramshahr-Iran

<sup>2</sup>Assistant Professor of Accounting, Persian Gulf International Educational Branch -Shahid Chamran

<sup>3</sup>Assistant Professor of Accounting, Persian Gulf International Educational Branch -Shahid Chamran University.Ahvaz. Iran

[Email address : alihossien@yahoo.com](mailto:alihossien@yahoo.com)

**Abstract:** This study examines the impact of performance audit implementation on the improvement of efficiency of the public sector management systems. In terms of research plan, it is a survey and survey tools in this study are two five-choice (Likert) researcher-made questionnaires which are identified to audit performance and productivity, both with high reliability and validity. Regarding the temporal scope, the research was conducted in the summer of 2012, and the spatial scope of the study is the Supreme Audit Court of Iran in all the provinces. The required sample size (357) was determined using Cochran's formula (which represents the population as much as possible). The t-student test and SPSS software were used to test research's three hypotheses. Given that the data obtained by questionnaires is qualitative information, non-parametric tests (Pearson correlation coefficient) are also used and to test the research hypotheses, multiple regression and binomial test are used. Thus, to prove the hypotheses, the options including "very high", "high" and "somewhat" are used as criterion. All other statistics used in this research include Z-test; statistics (T), (F) and (R), regression and path analysis equations. The results showed that: 1) performance audit may cause to improve management systems, 2) improvement of management systems enhances the productivity and, finally 3) the performance audit will enhance management systems productivity.

[Sirous Fattahi, Seyed Ali Vaez, Ali Hossein Hosseinzadeh. **An Examination on the Effect of the Performance Audit Implementation on the Improvement of the Productivity of Public Sector Management Systems in Iran (A Case Study in Supreme Audit Court)** *Life Sci J* 2012;9(4):1708-1724] (ISSN:1097-8135). <http://www.lifesciencesite.com>. 262

**Keywords:** Performance Audit, Management Systems Productivity, Supreme Audit Court, Economic Advantage, Efficiency, Effectiveness.

### Introduction

Today, due to the decreasing resources and increasing population and needs, productivity has attracted the attention of scientists, as an effective leverage in management and leadership of the community. Meanwhile, Islam, as the last divine religion which claims to offer a full and comprehensive plan required by contemporary human has presented exquisite and unique tips to Muslims through Holy Quran verses and infallible Imams' biography about the productivity of proper implementation of the right thing i.e. a combination of efficiency (output-input ratio) and effectiveness (comparing results with goals) with a cultural viewpoint, based on the comprehensive productivity system with an emphasis on the central role of human at both individual and social levels, so that they would think about it firstly and in the next step, would apply the lessons of productivity (Ahmadzadeh, 2010). The importance of the concept of productivity in our country have been neglected for various reasons including lack of a proper culture and attitude towards productivity in the society, and despite some measures taken such as establishment of National Iranian

Productivity Organization as well as some emphasis on productivity improvement in the Third Development Plan, there is still too much to get into a favorable situation, and essential and effective steps should be taken in this respect (Etemadi et al., 2009). Our country is no exception, in the development of which the concept of productivity has the greatest role.

On the other hand, with the economic globalization and evolution of various industries, managers have been engaged in achieving higher efficiency, so that they require some data beyond historical financial data for their organization to survive. Therefore, assessment of the current conditions through controlling and considering the approaches to achieve the goals of the organization and to be in harmony with the environment via innovation, identifying the improvement opportunities and remove the shortcomings of the internal control system to use the advancement opportunities based on the criteria including effectiveness, efficiency and economic advantage for managers are the basic need and a key to the organization's survival (Samsami, 2007). The organizations need a continuous improvement of their performance to survive and

develop in today's competitive world. In this regard, it is useful to use management control systems and latest technologies which help its development. The fundamental prerequisite to establish performance audit system in the organization is the need for this type of audit; actually admitting that all the problems of the organization cannot be solved altogether by the establishment of performance auditing unit in management control system (as an arm of management information), but it requires spending much more time and costs (Absalan, 2007).

Thus, this paper is trying to discuss various approaches and strategies to increase such productivity through implementing performance audit while referring the main concepts of management systems productivity. Now, the following question is raised: "Is the performance audit implementation effective on productivity indices and improvement of productivity of public sector management systems?"

To answer this question and considering the importance of the subject and given that no comprehensive research has been conducted in this regard in the country, this study aims to examine the effect of performance audit implementation on the improvement of productivity of public sector management systems.

## **1 - Introduction and Statement of the Problem (Subject)**

### **1-1 - Concepts and principles of Efficient Management Systems**

Many senior and middle managers believe that it is so hard to find any employee or worker who is able to do everything! Managers always argue that employees are lazy and expect the highest salary for their minimal amount of work. The number of organizations that have a low level of productivity is not very low and the impact of this harsh reality affects directly the net production of a country. The employees in such an organization believe that organizational loyalty between them is not very high; disregarding its origination, this is one of the most important factors in reducing productivity in any organization (Karegar and Faraj Poor, 2009).

However, contrary to what many managers and supervisors believe, the workers should not be blamed with such haste. Although manpower plays a major role in increasing or decreasing the productivity of any organization, it is not the only factor affecting the productivity. It seems like you consider your weakness and lethargy as an indicative of your cold. Low productivity of manpower suggests to the existence of inefficient management systems. For example, if a shoemaking machine has a poor design; it will produce low-quality shoes, even if skilled workers and good leather are used. The use of poor leather in a good machine will also lead to the production of low-

quality shoes. Thus, it should be noted that manpower is not the only factor affecting the productivity. In this particular example, the proper management can help improving the productivity. If we generalize this example to the organizations, we will see that the manpower plays the role of an input into a production system that can turn into good employees under the leadership of managers. Edward Deming, the renowned professor of quality management, believes that 85 percent of problems in any organization refer to its management levels and the staff is responsible only for the rest 15% of problems. Although there may be some debates and controversies in these figures, it is evident that the most issues and problems of the organizations are related to the shortcomings of the systems which, in most cases, decline due to administrative reasons (Howardell, 2003).

The analysis of productivity improvement can be performed at micro activity and levels or in macro structure and levels of the organization; in brief, it can be said that to improve the efficiency at micro levels, working methods should be defined and improved considering the inputs, output goals, nature and philosophy of work as well as remarkable cultural tips. In the structural analysis, the optimal accessible points should be focused based on the macro goals and objectives of the organization. Inputs such as business strategy of the organization, management philosophy and the organizational culture are all among the factors determining and affecting the productivity of the organization which cannot be easily measured. Thus, different schools are developed in management science which are all trying to improve the productivity of the organization including methods such as Management by Objectives (MBO), Total Quality Management (TQM), Business Process Reengineering (BPR), Activity-based Management (ABM), Management by Project (MBP), Team-based Management (TBM), etc. Unfortunately, there is no universally accepted model for improving the productivity of the organization and the discussions presented are the only guidelines, the effective implementation of which is strongly influenced by inherent nature of the organizations and the individuals' commitment to preserve and apply them (Howardell, 2003).

### **1-2 - Concepts, Definitions and Principles of Performance Audit**

In today's world, leading managers always try to gain the required confidence through close monitoring and objective evaluation of their own and others' tasks in order to be strong and dominant against the incoming problems, and to do their own works properly and timely. Thus, they should never hesitate to use services of experts and the specialists from outside their organization to identify problems and

provide solutions to achieve more increasing successes using such services. The Performance audit and its related services are among tools that are developed aiming to help managers for better guidance and leadership of economic units and to run enterprises through evaluating the effectiveness, efficiency and economic advantage in the enterprises and presenting practical suggestions, and it includes qualitative assessment of the tools possessed by the management (Hosseinzadeh, 2008).

In recent decades, evaluation and auditing systems in public and private sectors in most industrialized countries have been referred to as Operational Auditing, Performance Audit, Management Audit, Program Audit or Comprehensive Audit. These audits in the public sector in the past have focused on the achievement of objectives, law enforcement, implementation of regulations, policies, procedures as well as receiving and consuming budget. While, in recent years, improvement of management performance, increase of productivity in this sector and reduction of the costs of the lost opportunities is emphasized. It should be noted that the term 'performance audit' is used in public sector. This term is always used in the Government Auditing Standards and its use in Iran has been approved by steering committee of performance audit of Supreme Audit Court (Rahimian, 2011).

In case we consider the auditing as a systematic process in impartial collection and evaluation of the evidence and documents related to financial events and activities to determine their degree of compliance with predetermined criteria and to report the results to the stakeholders, Supreme Audit Institutions can play an effective role in promoting transparency and accountability level. Government auditing in Iran is performed by independent auditors of Supreme Audit Court with specified jurisdictions and authorities. Supreme Audit Court of Iran, as a supreme institution of financial supervision in the country in a very high position, resulting from the principles 54 and 55 of the constitution, monitors continuously how to use credit and the related results across the country. The Supreme Audit Court is a guarantor for the accountability of different managers to the rules and regulations via public prosecutor office, and in this regard, the triple powers<sup>1</sup> and all the governmental organizations, which somehow use the national budget, are obligated to be accountable to it. In addition, the results obtained from investigations of the auditors of Supreme Audit Court are annually prepared in the form of clear budget settlement

reports, and are presented to Islamic Parliament and are published to notify the public. The Supreme Audit Court plays its role through continuous presence in executive agencies including public companies and the assessment of their activities and plans in form of performance audit; so that it would play its role in applying internal controls and improving their operations by monitoring the establishment and implementation of the systems used by the executive agencies and leads economic system of the country at micro levels and the organization itself by presenting their viewpoints to the respective agencies.

### **1-3- The Necessity to Implement Performance Audit for Improving the Management Systems Productivity**

Management is defined as the knowledge of using resources effectively and efficiently to achieve organizational goals and such resources usually include capital, manpower and all other resources provided to the organization. A manager should plan, organize and control the organization's operation to achieve maximum benefits. In today's world, responsible and leading managers are always trying to ensure accurate supervision and objective evaluation of their own tasks in order to stay strong and dominant against the incoming issues and to do properly and timely their works. Therefore, they should never hesitate to use services provided by the experts and specialists from outside their organization to identify problems and provide solutions to achieve an increasing successes using these services (Auditor Management Journal, 2009). Reduction of resource, increased operating costs, the growing organizational size and complexities are among challenges that the organizations are facing in recent decades that made managers to evaluate and improve the efficiency and effectiveness of organizations. One of the ways to improve effectiveness and efficiency is the performance audit implementation (Drucker, 1975; Henke, 1972).

The increasing development of human and the changes thereto have led to a significant growth in all areas for which audit profession is no exception and has been always developed as influenced by human societies. On the other hand, the importance of the agencies and organizations has challenged audit profession greatly and this major challenge has led to fundamental changes in the audit profession in the world to meet the needs of managers, politicians and representatives of people. This major challenge and subsequently, the need to overcome it, have resulted in an emergence of a new type of audit called performance audit. This type of audit has considered all financial and operational aspects and improves the productivity of resources management.

<sup>1</sup> The Legislative, the Executive and the Judiciary

The Performance Audit is a tool provided to managers for identifying problems and removing straits with no censorious and critical view and it is not aimed to criticize the current operation, but is going to review the operation through cooperating with management and staff and to develop a plan for improving the operation. Thus, the performance audit should be considered as a review plan to make the operations economic and efficient in order to have increasing results (Reid, 2005). Operational audit is one of the techniques that could help managers by evaluating the effectiveness, efficiency and economic advantage of operations of the organization or the company and offering suggestions to improve operations in today's variable business environment.

In recent years, the focus and scope of many audits in public and private sectors has undergone changes and since financial statements alone cannot meet the informational needs of management, the managers in these two sectors are looking for collecting more information in order to assess and judge the quality of operations and operational improvements. As a result of creation of such backgrounds, the need for performance auditing techniques to assess the effectiveness, efficiency and economy of operations has increased dramatically. Investigating the reasons for increasing demand to receive performance auditing services shows that two following subjects have provided a proper ground to implement such audit:

- Leading the managers to pay more attention to the observance of economic advantage, efficiency and effectiveness in economic units;

- Promoting the independent auditors' experience in identifying and finding the existing realities in financial auditing, management consulting and providing necessary guidelines to the managers (Nokhbe Fallah, 2005). The study will attempt to measure the productivity of management resources in public sectors, while measuring the impact of performance audit on its improvement in order to provide required grounds for further implementation of audits and to improve productivity of management resources and consequently, the country's economic growth and prosperity.

#### **1-4- The Indicators of Efficient Management Systems**

The establishment of productivity improvement management cycle causes the productivity to improve as a continuous process and the productivity path to be specified and necessary preparations to be conducted. Productivity movement is the prerequisite to the organization development and will result in institutionalization of the improvement in different organizational systems (Soltani, 2011). Trust building in the work place and human relationship between the

manager and employees by providing detailed information about the organizational operations to the staff, reviewing personnel problems, holding friendly meetings and providing the proper organizational atmosphere along with supporting the staff while respecting the dignity and status of the management, helps the manager achieve productivity and fulfill the organizational goals (Wikipedia Encyclopedia<sup>2</sup>).

Hersey and Blanchard (1988) argue that the task of manager or leader of the organization is important, because it is interacted with its all surrounding environmental variables. The managers should have outstanding features and apply appropriate procedures according to the situation of the organization by relying on the results and the conducted studies on management issues, and also provide the ground to achieve the organizational goals by creating a favorable organizational environment. French (1986) considers the organizational survival and achievement to be dependent on the managers' attention to the factors of external environment, internal environment (organizational) and outputs (results). These factors affect each other. For example, the organization management (the internal factor) affects the legal principles of employment (an external factor) through strengthening and supporting educational programs. Now, the most important indicators of efficient management systems are presented in this study as follows:

#### **1-4-1- Implementation of Performance Management System and Outcome-based Salary Payment**

Manny (2002) believes that review and analysis of information emphasize that performance evaluation systems motivate employees' management to improve productivity. Meanwhile, merit-based payment increases the effect of employees' motivation. The other alternatives of motivators also affect the employees' occupational performance. Through improving the organizational atmosphere and creating empathy between employees and alignment between goals of the employees and the organization, performance management strives to increase the productivity of manpower and subsequently, the productivity of the entire organization by leading the employee in achieving the organizational goals by strengthening the optimal performance and eliminating poor performance using incentive payment methods (Karegar, 2010). With a comprehensive viewpoint to the organization's productivity performance, the performance management always presents a clear view of the productivity of the

---

<sup>2</sup> <http://fa.wikipedia.ir>

organization. When process and performance of the organization are managed, its productivity and optimization will be ensured. In general, the establishment of performance management in the following aspects will help to improve the productivity management cycle (Soltani, 2011): Provides reform and improvement in the manpower; - Unifies personal goals and the organizational productivity objectives; - Provides the ground for the structure reform in productivity; - The process of proper problem finding in productivity dominates the organizations; - Creates motivation through distinguishing inefficient people from efficient people; - Create synergy in the organizational productivity; - Presents new beliefs about the organizational productivity.

#### **1-4-2- Establishment of a System of Suggestions**

The suggestions system consists of two words of system meaning a set of interconnected components which have interactive impression and effect and strive for a common goal and the concept of suggestion which is any new thought and idea which can create a positive change, improve a method, increase quality, reduce costs and enhance the staff morale. Suggestion system is a technique applying which, the staff's thought and idea can be used to identify problems and resolve them so that the employees at all levels would be involved in management. Improvement of mental health, flexibility, risk-taking and effectiveness against the demands of intra-organizational and extra-organizational customers, creativity and practicing the staff's internal talents, process improvement through suggestion system, improvement of work environment conditions, increase of customer satisfaction, increase of the organizational belonging sense, aligning individual goals with organizational goals, developing and strengthening the relationship between employees and management, informing the organization's senior manager of the employees' capabilities and optimal use of it, improving the information circulation and information systems, strengthening organizational commitment and ultimately increase of productivity. The main aim of implementing this system is to improve workflow and value human personality and dignity of staff and ultimately, increase productivity in the organization. In most industrialized countries, suggestion system has been implemented for more than six decades to improve the quality, reduce waste and increased the productivity. Using creativity of employees and their reasoning and mental involvement and participation in solving problems in work place and the organization through suggestion system, some innovations can be achieved in the organization and the continuous improvement which is another principle presented in productivity can be

obtained and new ways will be constantly obtained to increase productivity through innovating (Saleh Olia and Dehestani, Biti).

#### **1-4-2-1- Establishment of an Idea-creating Suggestion System**

This indicator reflects the ideas and suggestions that help the employees' mental talents to improve the organizational productivity.

#### **1-4-2-2- Establishment of an Entrepreneurial Suggestion System**

Entrepreneurial suggestions are how to perform issues by receiving constructive suggestions to improve the task productivity. These suggestions are somehow effective and show how to perform tasks through innovating. It also includes creation of new jobs, according to the assigned tasks and authorities.

#### **1-4-3- Implementation of Total Quality Management "Tqm" (Collective participation of the organization to achieve goals)**

Participatory management is the dominant paradigm of modern management that is based on the cooperation of staff and the manager to achieve the organizational goals in a friendly environment full of understanding. The staff's views and plans lead to the greater efficiency of the organizational operations through savings, innovation in the issues and management improvement (Karegar and Faraj Poor, 2009). The system (tqm) is an efficient structure, and that is because in total quality management, it is the responsibility of senior managers of the organization to improve quality and productivity rather than only a specific unit of the organization. TQM does not only refer to the product and has a comprehensive view towards the organization and product and includes all activities, processes and detailed work (Soltani, 2011).

In change process, the active involvement of all employees to create a favorable atmosphere and attitudes to work is important to improve productivity. Participation not only helps an organization to change; but also it has a deep educational impact. Rad et al. (2003) claim that participation in works is the key factor in productivity. Also, cooperation theory is to describe the relationship between participation, and improvement of performance and productivity. In addition, Brown (1999) states that participation increases the employees' productivity when it is used as a factor for motivating employees and they can also monitor the colleagues' work, which is a type of management. He also notes that all group incentive plans indicate the participation of staff in management and control. Several studies and experiments demonstrate that the quality and style of leadership have a great effect on production rate, efficiency, and satisfaction and morale of the employees. Meanwhile, one of the principles that are directly related to manpower development, as mentioned above, is to

make employees participate in affairs by the managers (Nasrallah Pour, 2005).

Applying participation generally brings enormous benefits for the organization, which is entirely to increase productivity; these benefits briefly include (Karegar and Faraj Poor, 2009): - Participation will lead to more effective decisions in the environment; - It challenges ingenuity and creativity of all the employees; - Strengths human respect, social dignity and status, motivation and common mutual interests between management and personnel; - Stimulates and encourages the employees to take responsibility; - Improves people's morale and teamwork; - Prepares people to easily accept the changes that should be made in the organization, if necessary, and not to allow any problem to occur in such cases.

#### **1-4-4- Establishment of Management Governance System and Control of Management over the Issues, etc.**

This index is a manifestation of management systems that affects productivity, so that the more consistent is the governance system of an organization, subsequently, the better and more efficient and effective control it will have over the affairs. However, it should not be forgotten that the purpose is not lack of organizational participation and doing all issues and focusing on all of them in the management department, but it is to establish a suitable systems for management controls in the organization.

#### **1-4-5- Implementation and Deployment of Successful Planning-Based Management System**

An effective and efficient management always uses the application of strategic planning system in conducting affairs so that the process of conducting affairs would be specified in accordance with the predetermined plan and goals would be manifested and the path to achieve the objectives would be clarified. Therefore, this indicator plays an essential role in the effectiveness and efficiency.

#### **1-4-6- Establishment of Planning Stability**

Although a coherent planning system is essential to improve the organizational productivity, the organization will not have the required productivity as long as these planning have not been actualized. This indicator is complementary to the previous indicator, so that by implementing and stabilizing planning, productivity management will improve in long time.

#### **1-4-7- Establishment of Effective and Efficient Management Information Systems**

Information systems include systems that facilitate the organizational management decisions and accelerate their process. These systems must have the necessary efficiency and effectiveness as well as comprehensiveness to show all aspects of an

organization. Such efficient and effective systems help managers achieve goals more immediately and enhance the organizational productivity.

## **2- Review of the Literature**

### **2-1- Efficient Management Systems**

Ross (1977) considers the organizational productivity as a of resources, management of subordinates and management tasks and believes that leading staff to use their talents and abilities more and more results in a higher level of the organizational productivity and thus, job satisfaction. In addition, human resources management and management actions regarding job design, enrichment and prosperity, job rotation and change affects the productivity level of employees.

In their research, Ellis and Dick (2003) concluded that in organizations that in the organizations that work as groups and their managers employ participatory leadership method, productivity will be improved. Orin's research (1991) on service industries of America Colorado also shows that productivity level and job satisfaction of the industry staff will increase by implementing participatory decision making techniques (Habibi, 2004).

In a cross-sectional study conducted in the first half of 2009, Mostafa Allah Verdi et al. (2009) showed that observing the factors related to the management style and method with the average score (4.41), is found to be the most important factor affecting manpower productivity. The factors related to the individual, culture, organizational structure, reward systems, training courses, and factors related to the physical environment of the organization were at the next levels of importance.

In the successful implementation of a program to improve the productivity of the manpower in the health sector, the role of management and its style in the administration of affairs should not be ignored. Similar to the results in this study, Tavari et al. (2008) showed in their study that managerial factors were at first priority in influencing the productivity of the workforce.

In the comprehensive model of management, the factors affecting the productivity of manpower designed by Alvani and Ahmadi (2002), leadership style was one of the eight factors which were essential in improving the productivity of manpower. In his study, Abili (2009) distinguished the factors related to the leadership type and management attitude from the organizational factors related to the productivity of middle managers.

Soltani (2011) have claimed that establishment of a productivity improvement management cycle requires serious intent and operational mechanisms should be designed and used in this regard. Before designing these mechanisms, pathology of the

organizational productivity status causes the operational mechanisms to be designed in accordance with the organizational requirements and experienced practical solutions such as can institutionalization of productivity in thought, institutionalization of savings, designing efficient structures, manpower development, designing productivity research system and deployment of performance management can be used for improving productivity in the organizations.

Another study is also conducted on the organizational productivity and its influencing factors and it has been concluded that factors such as continuous professional education of managers and employees, improving motivation among employees to work better and more, developing appropriate areas for innovation and creativity of managers and employees, establishing a proper performance-based payment system and establishing a system of punishment and reward and conscience work and social discipline, development of activity methods and systems that have a critical role are among the factors affecting the organizational productivity (Mirkamali and Mirsanai, 2001).

Saleh Olia and Dehestani (Bita) concluded that productivity improvement is possible through suggestion system by providing infrastructure principles of productivity topic, which is the clever use of resources and continuous improvement. In this regard, an example one of the suggestions presented in suggestion system of Yazd Gas Company was investigated and the role of suggestion system was shown in total quality management (TQM) with the effect of this system on all principles, which is customer orientation of collective participation and continuous improvement.

Vaziri et al. (2009) conducted a study titled as "identifying and prioritizing the factors affecting the manpower productivity (Case Study: Employees of Hormozgan Department of Education) using ranking techniques (MADM) through descriptive-survey methodology and library-field data collection tool. The results obtained from applying the (MADM) techniques such as TOPSIS and AHP suggests that among the mentioned factors, the structural/managerial factors (non-discrimination and observance of the organizational justice, participatory management and establishment of appropriate suggestion system and proper performance-based payment system) are respectively the most effective components in increasing manpower productivity among employees of Hormozgan Department of Education.

Dr. Hasan Asadi et al. (2004) showed that there is a significant relationship between creativity, risk-taking, leadership, support, integrity and solidarity, control, identity and reward system and productivity

of managers of Physical Education and Department of Education throughout the country. The study results showed that there is a significant relationship between organizational culture and productivity of managers and confidence level (99%).

Dr. Davoud Soleimani (2004) argued that low performance and productivity of some organizations is due to the organizational managers and leaders' lack of understanding of the cultural context of the existing society and the dominant organizational culture and not to meet the needs of employees and lack of the organizational democracy and collective participation as well as the organizational leadership which is influenced by self-fascination and mania.

The only way to eliminate redundancies for having an efficient and high quality system in production is continuous improvement though participation of all employees in the implementation of. This fact is clearly revealed in the descriptions of Robinson and Schroeder (2004) (Batman Ghelich, 2009).

The study of Habibi (2004) showed that there is a significant positive relationship between suggestion system, job satisfaction as well as staff motivation in the staff field of the organization of inspection and supervision of prices and goods distribution and services.

Nasrallah Pour (2005) claims that participation in works is the key factor in productivity. Cooperation theory also shows the relationship between participation and productivity.

The results of the study conducted by Taheri (1999) show that professional education, motivation improvement, creating appropriate context for initiative and creativity, establishment of proper performance-based payment system and system of punishment and reward, conscience work and social discipline, evolution of systems and methods and strengthening governance and domination of the organization's policies on issues are among the factors affecting man power productivity.

In his study, Yousefi (1387) states that one of the factors which has a significant effect on improving manpower productivity is the improvement of the dominant relationships between management and employees and using proper and scientific leadership style as well as the manager's attention to the employees' problems and life are among the components affecting the increase of productivity.

In their research, Ellis and Dick (2003) concluded that applying participatory leadership style for teamwork will improve productivity.

Reviewing the conducted studies, Becker and Gerhart (1996) claim that the decisions associated with the human resources management, such as autonomous work teams, job rotation, quality control

circles, suggestion systems, system of managing complaints by improving the efficiency of the organization resulting in reduction of costs or increase of revenues of the organization, will enhance the organizational performance.

Lock (1999) showed that there is a positive relationship between management practices, productivity, job satisfaction and organizational commitment of employees and the managers' behavior is the key to productivity. The results of another study suggest that leadership and management methods have a significant effect on the manpower productivity. (Bain, 1988)

Results of the study of Wright (1990) and Pastore et al. (1995) suggest that support and establishment of a constructive relationship between managers and subordinates have the greatest impact on increasing the employees' productivity. Roger (1996) also conducted another study in this field. The results suggest that leadership, teamwork, participation and the correlation among the team members and managers, will significantly improve productivity.

Kudyba (2003) has also conducted a research on the factors affecting the improvement of productivity of the studied staff. The results of this study show that the employees' skills can be improved with proper training, guidance and involving, and will lead to the increase of the organizational efficiency.

According to the research conducted by Kunar Lee (1996) on 20 managers and 97 employees at a hospital in America, the statistics show that there is a positive relationship between management practices and productivity, job satisfaction and the organizational commitment of staff. These studies also showed that there is a significant relationship between the managers' behavior as the key to productivity and the employees' satisfaction with the organizational commitment (Lock et al, 1999).

## **2-2- Performance Audit**

In his MS thesis (Industrial Engineering, Islamic Azad University, Najaf Abad), Ahmad Dehghan Nayeri (2005) examined the interaction of value engineering and performance audit in productivity of constructional projects. In this study, the effect of value engineering implementation was examined in facilitating the implementation of performance audit and reversely as guarantor of the implementation of value engineering suggestions and the opinions of advisors, contractors, and experts etc. were collected while preparing hypotheses and questionnaire and after approving the hypotheses (the interaction of value engineering and performance audit in productivity of constructional projects), eventually presented solutions for better value management and cost reduction.

In another study conducted by Mohsen Jafari (2002-2003) titled as "examination of the implementing barriers of operational audit in the insurance industry (property insurance) the results revealed that non-documented nature of management control system and lack of appropriate experimental models in the field of operational audit at confidence level of 95% were identified as the implementing barriers of operational audit.

In his MS thesis, Mansoor Shah Mohammadi (1998) has reviewed "the barriers and problems on the implementation of operational audit in Iran". In this study, the researcher has examined the barriers and problems from two different aspects. The first hypothesis has examined the executives' lack of awareness of the benefits of operational audit and the second hypothesis has reviewed unfamiliarity of college graduates with operational audit. In the end, it has been concluded that operational audit is not well known in Iran and there is no adequate training in this area.

In his MS thesis (Tehran University, School of Management), Alireza KhodaKarami (2001) has examined the role of performance audit in motivating managers. In addition, since performance audit is a process consisted of components, indicators, benchmarks and etc., there are principally other purposes for this research, including the examination of whether each of components and benefits of performance auditing such as presenting suggestions to improve the operations and identifying opportunities, capabilities and improvement strategies can be involved in motivating managers or not, which were confirmed by hypotheses testing.

Palyt (2003) examined operational auditing procedures in five top audit institutions in Finland, France, Netherlands, Switzerland and the United Kingdom. The purpose of this study was to describe the strategic and important choices of five top institutions. This researcher focused on the applied methods, practical standards, operational auditor's skills, and operational auditing reporting. He found that the operational auditor's role is not only beyond observance of internal and external laws and regulations, but it often has aspects of management consulting for progress of issues (Dahanayaki, 2007).

A research was conducted by Jooypa (2010) titled as "pathology of performance audit implementation by the Supreme Audit Court and presenting suggestions to improve it. He considers the following factors to be barriers to performance audit implementation by the Supreme Audit Court in order of importance. These factors include lack of adequate and necessary training and skills for Supreme Audit Court auditors, inadequate budgeting system, lack of appropriate indicators for evaluating the performance



of executive agencies, non-clarification of executives in responding to Supreme Audit Court auditors, inadequate system for collecting and maintaining financial and operational statistics and data and lack of legal authority (in the law of the Supreme Audit Court) to implement performance audit.

### 3 - Research Hypotheses

According to the history and exploratory studies, the main questions of this research can be outlined as follows:

- ❖ Performance audit leads to economical, efficient and effective use of management systems.
- ❖ The economical, efficient and effective use of management systems will enhance productivity.
- ❖ Performance audit will enhance productivity of management systems.

### 4- Research Methodology

The subject of this study has been selected titled as “the examination of the impact of performance audit implementation on improving the productivity of public sector management systems. This research intends to partly present theoretical foundations related to the performance audit and productivity of management systems and then to discuss the factors that can improve productivity of public sector management systems through proper implementation of performance audit. In this study, in order to understand the views of experts, questionnaires have been used as data collection tool.

#### 4-1- Data Collection Method

This study is descriptive-analytical in terms of deduction and is survey in terms of research plan. Survey tool in this study is questionnaire. In addition, the study is deductive-inductive in terms of methodology. In other words, research hypotheses are formed based on inductive reasoning and data is collected deductively. To confirm or reject the hypotheses, the data is collected from the selected samples using questionnaires and then, rejection or confirmation of hypotheses will be tested after analyzing the obtained data.

On the other hand, the study is correlational. This method tries to review the amount of changes made by one or more factors in one or more other factors (Khalatbari, 2008). In this study, the researcher has selected some of the predictor variables without manipulating variables, and has investigated their relationship with the criterion variable and has tried to determine what relationship these predictor variables have with the criterion variable. Therefore, in this study where the researcher has examined the relationship between performance audit components and management systems productivity, the selected method is suitable.

This research is applied in terms of purpose, and is case-study in terms of the type of examination. In

data collection for theoretical studies and research background, library method has been used through articles, books, magazines and valid websites. To collect data related to confirmation or rejection of hypothesis testing, field method using the researcher-made five-option questionnaire (Likert) was applied. After distributing the five-option questionnaire among members of the population and getting answers from the subjects, the obtained data was classified, summarized and their validity was analyzed. Then, these data were analyzed analytically and the results were compared with results from previous studies.

#### 4-2- Scope of Research

- ❖ Temporally, the scope of research is related to the time of obtaining and collecting data (summer 2012).
- ❖ Spatially, the scope of research is Supreme Audit Court of Iran in capitals and the provinces.
- ❖ Thematically, the scope of study is to examine the impact of performance audit implementation on improving the productivity of public sector management systems.

### 5- Population and Statistical Samples

#### 5-1- The statistical population of the study:

The study population includes all managers, assistants, auditors, experts at the Supreme Audit Court of (31) provinces and headquarters of Supreme Audit Court equal to (2000) subjects which will be sampled by the intended number through the method that will be explained. The population consisted of the individuals whose profession is audit, inspection and supervision and their academic disciplines are accounting, economics, law, construction, engineering (IT), etc. and are constantly in contact with laws and regulations, governmental financial reporting, and professional standards and criteria etc. Also, Supreme Audit Court has been selected as the population for the following reasons:

- As the regulatory arm of the Islamic Parliament, Supreme Audit Court directly deals with financial and operational affairs of public sectors and is ware of condition of executive agencies.

- Performance audit was first implemented by Supreme Audit Court as one of the new audits and has become more practical day by day, so that now, most of the performance audit reports during the last years have been implemented or are being implemented. Thus, it has more familiarity and expertise in state auditing issues (especially performance audit) compared to other organs.

- Research topics are developing in the Supreme Audit Court under the supervision of Department of Education more easily and specialized and approved by the Committee of Standards and Guidelines. Therefore, technical and scientific

capability of research scientific-research level of such studies is highly potential.

- The vast majority of scientific studies and research in Supreme Audit Court are conducted nationally which is due to the organization's supports at macro level and distributing the required information and in some cases, even presenting it to the intended scholar. However, this is possible only for auditors and other stakeholders of this Court.

**5-2- Research Samples**

**5-2-1- Sampling method and sample size determination:** in this study, multi-stage cluster sampling and random sampling have been used and to collect data from the study population, the sampling is performed using Cochran formula (Ventling Team, 1997). In this study, different subsections have been

specified and in each stage, the intended sample was selected using Morgan-Krjy table. Obviously, at each section, the number of people was determined in proportion to the number of employees. Also, to determine sample size, since the analysis of small sample groups may result in unstable values and is likely to give misleading results, sample size was determined relatively large to be 357 subjects through regular random sampling. Therefore, to calculate the number of samples required which also represent the population as much as possible, the Cochran formula (equation 1) was used as follows:

**Equation (1)-Cochran Formula**

Confidence level

$$N = \frac{Nt^2pq}{D^2(n-t)}$$

N= Population, N= Sample size, p= trait, q- Statistics of lack of trait

d= Significant error 5%  
t = 1 /96 Confidence level of 95%

**5-2-2 - Descriptive specifications of sample:** 329 out of 357 selected subjects were auditors and 28 subjects were experts etc., (310) of whom were males and 47 were females. 10 subjects had associate degree, (251) subjects had a bachelor's degree, 91 subjects had master's degree, and (5) subjects had a PhD degree. Their average work experience was (15) years and they were in the range of (1) to (30) years of work experience.

**6- Data Collection and Measurement Tools, Validity and Reliability of Tools**

The data collection tools in this study was the researcher-made closed questionnaire to prepare which authentic standard questionnaires are used whose questions and options have been used according to the research hypotheses and objectives. In this research, to investigate and analyze the study variables which were discussed in the literature review and ultimately to measure components and indicators of performance audit and management systems productivity, two questionnaires were prepared one of which was related to performance audit and the other one was related to productivity of public sector management resources. A total of 357 questionnaires were distributed among auditors of Supreme Audit Court. After approval of reliability and validity of the questionnaire, it was provided to the samples. Likert scale has been used to measure data (Ganji, 2001). That is, qualitative traits will be converted into quantitative traits so that statistical analysis would be conducted based on the quantitative traits. To convert qualitative traits into quantitative traits, first, numerical values as shown in (table 1) are applied for each of the options of the questionnaire. After collecting the questionnaires, scores of each questionnaire will be calculated. Then, statistical analysis will be conducted and research results will be obtained.

**Table (1): the Numerical Value of Questionnaire Options**

Questionnaire Name	Question No.	Very Low	Low	Somewhat	High	Very High
The effect of performance audit on improving management systems (B-1)	19 to 26	1	2	3	4	5
The impact management systems improvement on total productivity (B-2)	19 to 26	1	2	3	4	5

**7. Data Analysis**

After data collection, data were analyzed using SPSS software version. 18. That is, the data were initially coded and inserted into the software. Then, they were analyzed in three parts of data using descriptive and inferential statistical methods. That is, initially, in the first and second parts, tables of frequency distribution and percentage frequency, and mean and variance were used to describe the samples' views about questions. This was performed in two significance levels of (sig=0 to sig =.05) of p-value. Then, in the third part, the research hypotheses were tested

based on the results of reviewing questions using heuristic statistics and ANOVA as well as multiple-regression and path analysis. Excel software was also used for drawing graphs.

### 7-1 - Descriptive Data Analysis

To investigate the research questions, descriptive statistics is used to design statistical frequency distribution tables (tables and charts showing the distribution frequency in the intended population) and to estimate central indices, arithmetic mean, measures of dispersion, standard deviation (SD) etc. Descriptive statistics, including mean, median, maximum, minimum and standard deviation of the data are calculated and presented in table (2). These values present only an overall schematic view of the distribution of research data. Descriptive indicators represent mean, variance and standard deviation of age and work experience and frequency and percentage frequency of male and female and their educational levels as well as frequency and percentage frequency of the options of each question that people have answered. This section has described demographic characteristics using tables. Tables are considered the most important tools to assess and measure data of a human-social study. The ultimate goal of the tables is to make the studied fact quantitative and measurable, and to provide an accurate picture of it as much as possible.

**Table 2: Frequency Distribution of Respondents in Terms of Central Indices**

Central Index	Gender	Age	Marital	Literacy	Side	History	Employment
N Valid	349	352	342	354	329	347	344
Missing	8	5	15	3	28	10	13
Median	1.00	2.00	2.00	3.00	3.00	3.00	4.00
Mode	1	2	2	3	3	3	4

### 7-2- Heuristic Data Analysis

#### 7-2-1- Research Hypotheses Testing

##### 7-2-1-1- Hypothesis (1)

**There is a significant relationship between performance audit implementation and the improvement and development of public sector management systems.**

The independent variable of performance audit implementation at a planned distance and the dependent variable of efficient management systems of public sectors are measured at the distance. Thus, Pearson statistical technique has been used to test this hypothesis. Statistical hypotheses are written as follows: the null hypothesis  $H_0: P=0$  and hypothesis one  $H_1: P>0$

In the null hypothesis, we assume that there is no relationship between performance audit implementation and efficient management systems of public sectors, and the opposite hypothesis suggests a relationship.

**Table (3): Testing Hypothesis One (1)**

Significance Level	Pearson coefficient	Standard deviation	Mean	Variable
0.000	0.61	0.655	3.69	Performance Audit Implementation
		0.666	3.91	Management Systems Improvement

**Table (3-1): Descriptive Statistics**

	Mean	Std. Deviation	N
Performance Audit	3.69	0.655	357
Management systems	3.91	0.666	357

**Table (3-2): Correlations**

Variables	Correlation	Performance Audit	Management systems
Performance Audit	Pearson Correlation	1	0.610 **
	Sig. (2-tailed)		0.000
	N	357	357
Management systems	Pearson Correlation	0.610 **	1

	Sig. (2-tailed)	0.000	
	N	357	357

Table (3-3): Model Summary

Model	R	R Square	Adjusted R Square	Std. Error of the Estimate
1	.901 <sup>a</sup>	0.813	0.812	0.307

Table (3-4): ANOVA<sup>b</sup>

Model		Sum of Squares	df	Mean Square	F	Sig.
1	Regression	144.627	1	144.627	1538.761	.000 <sup>A</sup>
	Residual	33.366	355	0.094		
	Total	177.993	356			

Table (3-5): Coefficients<sup>a</sup>

Model		Unstandardized Coefficients		Standardized Coefficients	t	Sig.
		B	Std. Error	Beta		
1	(Constant)	0.129	0.093		1.393	0.165
	Performance Audit	0.972	0.025	0.901	39.227	0.000

In the above tables, Pearson statistical technique is used for testing the significance of the relationship between performance audit implementation and the improvement of public sector management systems. As shown in the table results, the average rate of the performance audit implementation is (3.69) and the average improvement of public sector management systems is (3.91). Pearson coefficient has become ( $r=0.61$ ), which shows the high correlation between the two variables. The coefficient is positive and directly correlated; it means that the improvement of public sector management systems increases by increasing the performance audit implementation. Given that significance level ( $\text{sig}=0.000$ ) is smaller than 0.05, this relationship will be confirmed with 99% confidence. Thus, null hypothesis will not be confirmed. In addition, according to the tables (3 and 3-1 to 5), the path equation to confirm this hypothesis is as follows:

**Equation (2:) Testing Hypothesis (1)**

$$\alpha_{3V3} \text{ (Index of management systems improvement)} = .129 + .972 \times (\text{Performance Audit}) + .118$$

Figure 1: Path Analysis Testing of Hypothesis (1):

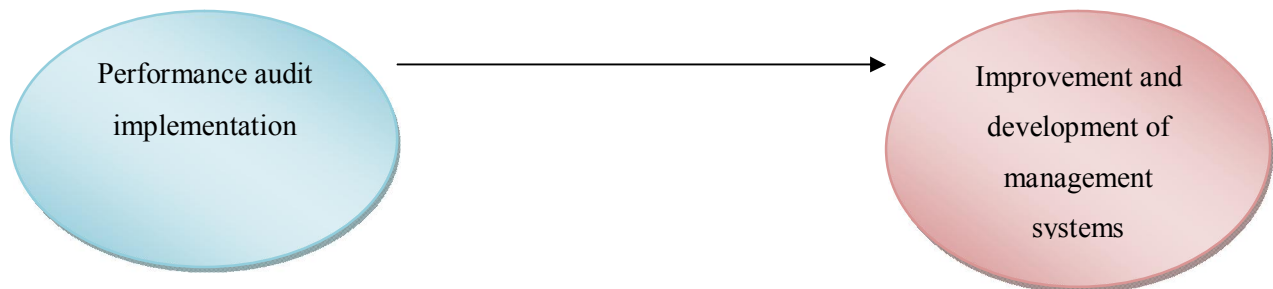
**7-2-1-1- Hypothesis (2)**

**There is a significant relationship between improvement, deployment, design and development of efficient management systems and the productivity of public sectors.**

The independent variable of improvement, development, design and deployment of efficient management systems at a planned distance and the dependent variable of productivity of public sectors are measured at the distance. Thus, Pearson statistical technique has been used to test this hypothesis. Statistical hypotheses are written as follows: the null hypothesis  $H_0: P=0$  and hypothesis one  $H_1: P>0$

In the null hypothesis, we assume that there is no relationship between the improvement, development, design and deployment of efficient management systems and productivity of public sectors, and the opposite hypothesis suggests a relationship.

**Table (4): Testing Hypothesis (2)**

Variable	Mean	Standard Deviation	Pearson Coefficient	Correlation	Significance Level
Improvement, development, design and implementation of management systems	3.71	0.707	0.61		0.000
Productivity of public sectors	3.9	0.567			

According to the above tables, Pearson statistical technique is used for testing the significance of the relationship between improvement, deployment, design and development of efficient management systems and the productivity of public sectors. As shown in the table results, the average rate of improvement, deployment, design and development of efficient management systems is (3.71) and the average productivity of public sectors is (3.9). Pearson coefficient has become ( $r= 0.61$ ), which shows the high correlation between the two variables. The coefficient is positive and directly correlated; it means that the productivity of public sectors increases by increasing the rate of improvement, deployment, design and development of efficient management systems. Given that significance level ( $sig=0.000$ ) is smaller than 0.05, this relationship will be confirmed with 99% confidence. Thus, null hypothesis will not be confirmed.

**Figure 2: Path Analysis Testing of Hypothesis (2):**

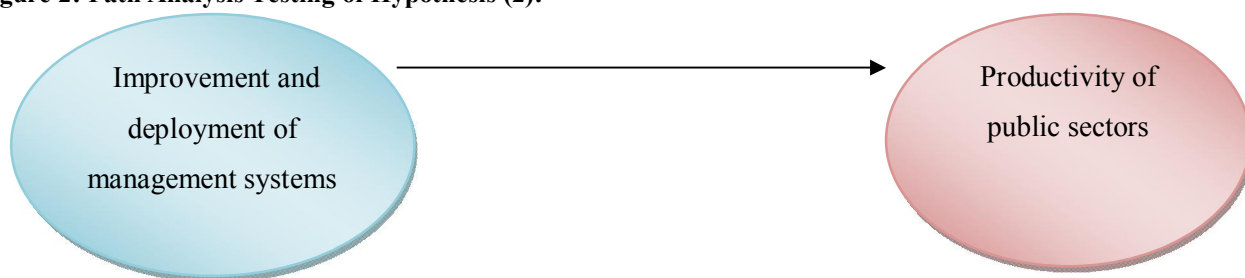

**7-2-1-3 - Hypothesis (3) - Research Subject**

**There is a significant relationship between performance audit implementation and the improvement of the productivity of public sector management systems.**

The independent variable of performance audit at a planned distance and the dependent variable of productivity of public sector management systems are measured at the distance. Thus, path analysis technique has been used as described in the following table:

**Table (5) Path Analysis of Hypothesis (3):**

Variable name	Direct Effect	Indirect Effect	Total Effect
The Performance audit implementation- productivity of management systems	---	0.17 * 0.901	0.1531

**Figure 3: Path Analysis Testing of Hypothesis (3):**

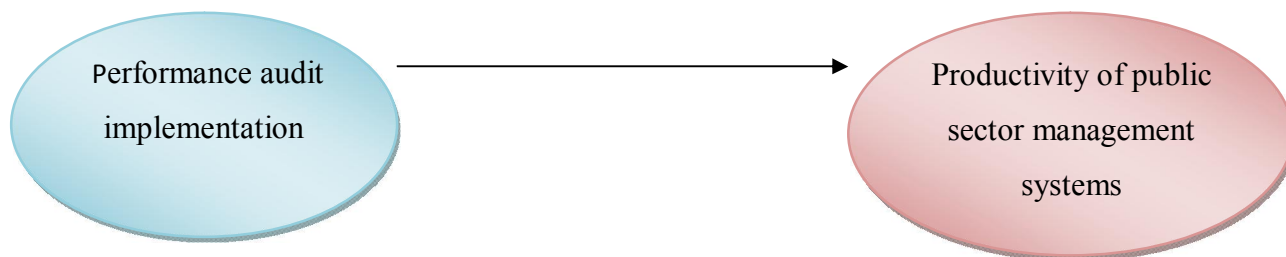

According to the data in table (5), after estimating direct and indirect effects of independent variables on productivity of management systems, according to all direct and indirect causal paths, the variable of performance audit implementation had an increasing impact on the productivity of public sector management systems. It means that wherever performance audit implementation has improved, the productivity of public sector management systems has also increased.

### 8- Conclusion

According to the results of the hypotheses 1 to 3, the following items are applicable: 1) Performance audit implementation improves public sector management systems. 2) Improvement and development of management systems improves productivity of the public sectors. 3) Performance audit implementation improves productivity of the public sector management systems.

### 9- Recommendations

According to the results of this study, the following recommendations are presented:

1. Great efforts should be put by supervisory agencies, particularly Supreme Audit Court, to show the results of the performance audit implementation to public sector managers.
2. It is recommended that the indicators, variables and the results of this study should be presented to the performance auditors and the government practitioners as a general model so that the ground would be provided for further improvements of productivity using these results.

### 10 – Research Limitations

In the implementation of research, considering its national aspect and extension across the country, the following items are the limitations which can be presented:

1. In the implementation of research, considering the lack of global standard questionnaire in both field of productivity and performance auditing, great time and effort were spent in identifying especially the indicators of productivity that led the research to be performed slowly.
2. Given that this research was conducted at the national level, the process of collection of questionnaires was slow and difficult and resulted in high costs.

### 11 - Future Researches

1. It is recommended that in the future researches, ranking of the effect of implementing various audits (financial, compliance, performance, or operational) on productivity should be considered.
2. It is recommended that in the future researches, the quality of performance audit and its relationship with auditor's specifications should be considered by researchers.
3. It is recommended that in the future research, the effect of performance audit implementation on the improvement of responsiveness of the public sectors should be considered.

### Persian Resources

1. Ahmad Zadeh, Mustafa. (2010). "Asr Sura; Charter of Quran productivity." *Journal of Qur'anic Studies*, 16th Year, No. 62-63, Summer and Fall 2010, pp.: 315-343.
2. Asad, Mohammad Reza; Hamidi, Mehrzad and Asadi, Hasan. (2002), "The relationship between (TQM) and its effectiveness in the headquarters of the country's sports organizations." *Journal of Physical Education (Journal of Motion)*, No. 14, winter 2002. pp.: 151-166.

3. Assadi, Hasan. & Rahavi, Roza. (2004). "The relationship between organizational culture and productivity of physical education managers of Departments of education across the country." *Journal of motion* No. 20, pp.: 23-34.
4. Etemadi, Hossein & Mehrabi koushki, Ali. & Ganji, Hamid Reza. (2009). "Examination of the relationship between the manpower productivity and stock returns of companies in Tehran Stock Exchange." *Management Landscape*, No. 33, winter 2009, pp.: 85-103.
5. Absalan, Leila. (2007). "Examination of the obstacles to the process of performance audit implementation in public state agencies." MS Thesis, Islamic Azad University, Arak.
6. Jafari, Mohsen. (2003). "Examination of the performance audit administrative barriers in the insurance industry (property insurance)." Islamic Azad University, Tehran.
7. Jooypa, Hasan. (2010). "pathology of performance audit implementation by the Supreme Audit Court and presenting suggestions to improve it." *Journal of Auditing Knowledge*, New Edition, 10<sup>th</sup> Year, No. 2, Fall 2010, pp.: 109-128.
8. Habibi, Lily. (2004). "review and analysis of the relationship between participatory management

- system (with emphasis on suggestion system) and the effectiveness of the inspection and supervision organization staff." MS thesis, Faculty of Management, Tehran University.
9. Hosseinzadeh, Molouk, (2008). "Performance Audit" Tadbir Monthly, 19th Year, No. 194.
  10. KhodaKarami, Alireza. (2001). "Study of the role of performance audit on managers' motivation".
  11. Khalatbari, Javad. (2008); "research statistics and methodology". Tehran, Pardazesh Publications.
  12. Dehghan Nayeri, Ahmad. (2005). "Examination of the interaction of value engineering and performance audit in productivity of constructional projects"
  13. Rahimian, Nezamedin. (2011); "Operational Auditing or performance audit." Auditing Organization, Auditor quarterly, 13<sup>th</sup> Year, No. 52, pp.: 68-69.
  14. Soltani, Iraj. (2011); "Process and solutions to use productivity management cycle in the organization." Molding Magazine, No. 64, pp.: 32-36.
  15. Soleimani, Davoud. (2004). "Quality of working life and its relationship with performance and productivity of organizations." Journal of Management Knowledge. No. 61.
  16. Shah Mohammadi, Mansour. (1998). "Examination of the barriers and problems on the implementation of operational audit in Iran." MS thesis, University of Allameh Tabatabai.
  17. Saleh Olia, Mohamed and Dehestani, Fahimeh. (Bita). "Review of the role of suggestion system in total quality management and its impact on the efficiency of the organization." Journal of Ravesh, 19th Year, No. 124.
  18. Samsami, Khodadad, Ehsan. (2007). "Examination of the barriers to performance audit implementation for management of the country's ministries." Master Thesis, Islamic Azad University of Qazvin.
  19. Taheri, Shahnam. (1999). "Productivity and its Analysis in the Organizations." Tehran, Hestan Publications.
  20. Karegar, Gholamrza, and Faraj Poor, Batoul. (2009), How to increase productivity in an organization. Bimonthly of Police Human Development, 6<sup>th</sup> Year, No. 23, June and July 2009. pp.: 45-78.
  21. Karegar, Gholamrza, and Faraj Poor, Batoul. (2009), How to increase productivity in an organization. Bimonthly of Police Human Development, 6<sup>th</sup> Year, No. 23, June and July 2009. pp.: 45-78.
  22. Karegar, Gholamrza, (2010). "Manpower optimization, a strategy for sustainable development of the organization: an analytical study of the causes and solutions." Police Human Development Bimonthly, 6<sup>th</sup> Year, No. 27, February and March 2009, pp.: 67-85.
  23. Ganji, Hamzeh. (2001); "Social psychology". Savalanfasl Publications, Iran (translated).
  24. Audit Encyclopedia Management. (2009); "Performance and operational auditing." Auditor Journal, No. 4, summer 1996, pp.: 31-59.
  25. Nokhbe Fallah, Afshin. (2005). "Performance and operational auditing." Tadbir Magazine, No. 165.
  26. Nasrallah Pour, Mojtaba. (2005). "Examination of the factors affecting the manpower productivity." Tadbir Magazine, No. 157.
  27. Vaziri, Soror Azam, and Mansouri, Hussein and Adiban Ahmed. (2009). "Identification and prioritization of the factors affecting the manpower productivity using MADM techniques (Case Study: employees of Hormozgan Department of Education)." Education Journal, No. 100. pp.: 135-159.
  28. Ventling Team. (Bita). "Planning for Effective Teaching." Translated by Chizari Muhammad. (1997). Tehran, Tarbiat Modarres University Press.
  29. Allahverdi, Mostafi and Farah Abadi, Mohammad Ehsan and Sajjad, Hanieh Sadat. (2009). "Prioritizing the factors affecting the manpower productivity from the viewpoint of middle managers of Isfahan University of Medical Sciences." Hospital Quarterly, 9<sup>th</sup> Year, No. 3 and 4, fall and winter 2010, No. 35, pp.: 75-85.
  30. Yousefi, Reza. (2008). "Growth of productivity in Pars Switch Company and its comparison with the fourth Development Plan." Seventh International Conference on Quality and Productivity in the Power Industry, Tehran, 19 June.
  31. ----- (-). "The first step to achieve excellence in quality and productivity." Translated by Isar Batman Ghelich, Asre-Keifiat Quarterly; No. 15, winter 2009. pp.: 65-72.

#### Latin Resources:

32. Abili KH, Jahed H. "Determining Related Organizational Factors to Productivity of Middle Managers". Journal of Psychology & Training Sciences: Vol. 1, No. 39, 2009.
33. Alvani M, Ahmadi P. Design of Total Pattern of Affecting Factors on the Manpower Productivity. Journal of Modares, Vol. 5 No. 1, 2002.

- 
34. Bain/ D. (1988). *The Productivity Precipitation/* New York/ Me Graw- Hill Book Company.
  35. Becker, B., Gerhart, B., "The Impact of Human Resource Management on the Organizational Performance: "Progress and Prospects", *Academy of Management Journal*, Vol. 39, No. 4, 1996, PP. 779–801.
  36. Dahanayake, Sunil J. (2007). "Value for Money Audit Function: The Conceptual Framework and Past Research Review". *The Chartered Accountant, the Institute of Chartered Accountant of Sri Lanka*.
  37. Drucker, M. (1975). *The Importance of Internal Auditing for Higher Educational Administration. The Internal Auditor*, 32(4), pp. 57-63.
  38. Ellis/ S./ Dick/ P. (2003). *Introduction to Organizational Behavior*. Mc- Graw Hill.
  39. French, W. L. (1986). *Human resources management*, Houghton –Mifflin Company.
  40. Henke, E.O. (1972). *Performance Evaluation for Non-profit Organizations. The Journal of Accountancy*, 133(6), pp. 51-2.
  41. Hersey,P, & Blanchard,K. (1988).*Management of organizational behavior*, PHI.
  42. Howardell, Doug (2003), "How to improve productivity-seven skills of a highly productive workforce", [teacagroup.com](http://teacagroup.com).
  43. Kudyba/ Stephan. (2003). *Knowledge management: The art of enhancing productivity and innovation by the manpower in your organization*. Published in *DM Review/ April*.
  44. Lock, J.C. (1999). *Leadership Behaviors*. <http://media.wiley.com>
  45. Lock, Jennifer and foong, chiok (1999). *Leadership Behaviors*, [http://media.wiley.com/assets/462/98/bus\\_lc\\_ib\\_foong.pdf](http://media.wiley.com/assets/462/98/bus_lc_ib_foong.pdf)
  46. Mirkamali, M., & Mirsanaye, Zh. (2001). *Investigating productivity and providing model to estimate it in training organizations, Management of Education and training*, No, 28 (In Persian).
  47. Pastore/ D.Inglis/ S & Danychuk/ K. (1995). *Understanding retention factors in coaching and athletic management: differences by gender/ positions geographic location. Journal of Sport Management/ Vol. 20/ No. 4/ PP: 427-441*.
  48. Reid, Milke , 2005, *Performance auditing of integrated Marketing Communication (IMC), actions and Outcomes , Journal of Advertising , 34.4*
  49. Roger/ M. (1996). *Pulling Through with Productivity/ Transportation and Distribution/ 36/ 9. Seonghee / C. / Harton. (2006). Measuring the impact of human resource management practices on hospitality firm's Performance. International Hospitality Management/ Elsevier Ltd*.
  50. Ross, Joel. E. *Managing Productivity*. Reston publishing Company, 1977.
  51. Tavari M, Sokhakeian M, Mirnejad SA. *Identification & Prioritize the Factors Affecting the Productivity of the Manpower with MADM Technique. Journal of Industry Management, Vol.1, No. 1, 2008*.
  52. Wright. P. M. (1990). *Operationalization of Goal difficulty as a moderator of goal difficulty: Performance Relationship. Journal of Applied Psychology/ 75/ PP: 227-234*.

10/15/2012



## Improved shoot organogenesis of *Echinacea angustifolia* DC treated with ethylene inhibitors

Soo Cheon Chae<sup>1</sup>, and Sang Un Park<sup>2,\*</sup>

<sup>1</sup>Department of Horticultural Science, College of Industrial Sciences, Kongju National University, 1 Daehoe-ri, Yesan-kun, Chungnam, 340-720, Korea

<sup>2</sup>Department of Crop Science, Chungnam National University, 99 Daehangno, Yuseong-Gu, Daejeon, 305-764, Korea

[supark@cnu.ac.kr](mailto:supark@cnu.ac.kr)

**Abstract:** With the goal of achieving better shoot organogenesis and plant regeneration in *Echinacea angustifolia*, we conducted an experiment to investigate the effect of ethylene inhibitors, including silver nitrate (AgNO<sub>3</sub>), aminoethoxyvinylglycine (AVG), and cobalt chloride (CoCl<sub>2</sub>). Leaf explants were cultured in initial shoot-regeneration media supplemented with different concentrations of AgNO<sub>3</sub>, AVG, and CoCl<sub>2</sub>. The addition of ethylene inhibitors improved regeneration frequency, giving a greater number of shoots per explant, and longer shoots. Shoot growth increased with increasing concentrations of ethylene inhibitors, except for CoCl<sub>2</sub>. The best shoot growth was found when AgNO<sub>3</sub> (10 mg/L) was incorporated in the medium. AVG (10 mg/L) produced the second greatest number of shoots. Treatment with CoCl<sub>2</sub> did not result in good shoot organogenesis in *E. angustifolia*. This study suggests that ethylene inhibitors, particularly AgNO<sub>3</sub>, could be used in a micropropagation and plant transformation protocol for regeneration of *E. angustifolia*.

[Chae SC, Park SU. **Improved shoot organogenesis of *Echinacea angustifolia* DC treated with ethylene inhibitors.** *Life Sci J* 2012;9(4):1725-1728] (ISSN:1097-8135). <http://www.lifesciencesite.com>. 263

**Keywords:** *Echinacea angustifolia* DC, ethylene inhibitors, plant regeneration, shoot organogenesis

### 1. Introduction

*Echinacea* species, members of the Asteraceae family, are among the most popular medicinal plants in North America and Europe (Pepping, 1999; Percival, 2000). *E. angustifolia* DC has been used by Native Americans of the Great Plains to treat a wide range of ailments, from venomous bites and stings, to infectious or inflammatory conditions such as cold and flu, toothaches, cough, sore eyes, and rheumatism (Kindscher, 1989; Barnes et al., 2005). Plant regeneration through successful shoot organogenesis generally requires correct establishment of media components, selection of a suitable explant, and control of the physical environment (Brown and Thorpe, 1986; Thorpe, 1990).

An important factor in the physical environment of plant tissue culture is ethylene. Ethylene (C<sub>2</sub>H<sub>4</sub>), a gaseous plant hormone, plays an important role in plant growth and development (Yang and Hoffman 1984). In plant tissue culture, ethylene can affect callus growth, shoot organogenesis, and somatic embryogenesis (Biddington, 1992; Huang et al. 2001; Jha et al., 2007; Chatfield and Raizada, 2008). While ethylene has certain positive effects on callus culture and root growth, this hormone largely functions to inhibit growth of the shoot.

Hence, for enhancing shoot regeneration, ethylene inhibitors are added to plant media to prevent the negative effects of the hormone (Chae et al., 2012; Park et al., 2012). The effects of ethylene

inhibitors, including aminoethoxyvinylglycine (AVG), cobalt chloride (CoCl<sub>2</sub>), benzyl isothiocyanate (BITC), aminocarboxy propionic acid, 1-methylcyclopropene (1-MCP), polyamines, silver nitrate (AgNO<sub>3</sub>), 3,4,5-trichlorophenol, and salicylic acid (2-hydroxy benzoic acid), on promoting shoot organogenesis in several plant species has been reviewed by Kumar et al. (1998). Regeneration of *E. angustifolia* via organogenesis or somatic embryogenesis from different explants has been previously reported (Harbage, 2001; Lakshmanan et al., 2002; Lucchesini et al., 2009).

In this paper, we report the establishment of an improved method for plant regeneration from stem explants of *E. angustifolia*. We examined for the first time the influence of ethylene inhibitors (AgNO<sub>3</sub>, AVG, and CoCl<sub>2</sub>) on shoot organogenesis of *E. angustifolia*.

### 2. Material and Methods

#### Plant material and culture medium

Seeds of *E. angustifolia* were purchased from Otto Richter and Sons Limited (Goodwood, Canada) and stored at 4°C. The seeds were surface-sterilized with 70% (v/v) ethanol for 30 s and 2% (v/v) sodium hypochlorite solution for 10 min, then rinsed three times in sterilized water. Ten seeds were placed on 25 mL of agar-solidified culture medium in Petri dishes (100 × 15 mm). The basal medium consisted of salts and Murashige and Skoog (MS) vitamins (Murashige and Skoog, 1962), solidified with 0.7%

(w/v) agar. The medium was adjusted to pH 5.8 before adding agar, and then sterilized by autoclaving at 121°C for 20 min. The seeds were germinated in a growth chamber at 25°C under standard, cool-white fluorescent tubes with a flux rate of 35  $\mu\text{mol s}^{-1} \text{m}^{-2}$  and a 16-h photoperiod.

### In vitro Shoot organogenesis

Stems of *E. angustifolia* were taken from plants grown in vitro, and were cut aseptically at the ends into sections of approximately 0.7 cm. Explants were placed on the medium in Petri dishes (100 × 25 mm). Each Petri dish contained approximately 25 mL of basal medium enhanced with 30 g/L sucrose, 7 g/L Phytagar, and 2 mg/L 6-benzylaminopurine (BAP), and seven explants were cultured in each dish. The pH of the medium was adjusted as for the germination medium, and the medium was sterilized using the same procedure. For improvement of shoot regeneration, the medium was optimized by testing the effect of different concentrations (0, 1, 5, 10, and 20 mg/L) of each ethylene inhibitor. Cultures were maintained at 25 ± 1 °C in a growth chamber with a 16-h photoperiod under standard, cool-white fluorescent tubes (35  $\mu\text{mol s}^{-1} \text{m}^{-2}$ ) for 6 weeks.

### Rooting of Regenerated Shoots

Regenerated shoots (~1.5 cm in length) were transferred to 1/2 MS medium in a Magenta box. The medium was solidified with 8 g/L plant agar and 50 mL was placed in each culture vessel. Four shoots were cultured in each culture vessel. Regenerated shoots were incubated at 25 ± 1 °C in a growth chamber with a 16-h photoperiod under standard cool white fluorescent tubes (35  $\mu\text{mol s}^{-1} \text{m}^{-2}$ ) for 5 weeks. After 5 weeks, the rooted plants were washed with water to remove agar, transferred to pots containing autoclaved vermiculite, and covered with polyethylene bags for 1 week to maintain high humidity. The plants were then transferred to soil and maintained in a growth chamber with a 16-h photoperiod and a day/night temperature of 18/20 °C for 2 weeks. These hardened plants were then transferred to the greenhouse.

### 3. Results and Discussion

Previously, a protocol was established for in vitro shoot organogenesis of *E. angustifolia* (Kim et al., 2010). However, shoot regeneration efficiency using this protocol was not satisfactory. For better shoot regeneration, we investigated the effect of ethylene inhibitors on the efficiency of shoot organogenesis in *E. angustifolia*. Application of AgNO<sub>3</sub>, AVG, and CoCl<sub>2</sub> improved regeneration frequency, giving higher numbers of shoots per explant and greater shoot length (Table 1). Shoot

growth increased with increasing concentrations of both AgNO<sub>3</sub> and AVG up to 10 mg/L, and declined with concentrations greater than 10 mg/L. The opposite phenomenon was observed in the application of CoCl<sub>2</sub>, where growth was inhibited with increased concentration. The greatest shoot growth was found when the generation medium (MS media with BAP at 2 mg/L) was supplemented with 10 mg/L AgNO<sub>3</sub>, achieving 89% regeneration frequency with the largest number of shoots (4.5) and the longest shoots (1.9 cm) in each explant (Table 1). Treatment with AgNO<sub>3</sub> produced 45% more shoots per explant, and 58% longer shoots compared to the control. Regeneration frequency was also 17% higher using AgNO<sub>3</sub> at 10 mg/L compared to the control. AVG (10 mg/L) produced the second greatest number of shoots, resulting in 39% more and 50% longer shoots compared to the control. Treatment with CoCl<sub>2</sub> did not result in good shoot organogenesis in *E. angustifolia*.

Ethylene is a gaseous plant hormone that influences plant growth and development (Yang and Hoffman, 1984). The silver ion (Ag<sup>+</sup>) inhibits ethylene action by substituting for Cu<sup>+</sup> at the active site of the ethylene receptor (Beyer, 1979), and cobaltous ions (Co<sup>2+</sup>) are known to inhibit ethylene synthesis (Lau and Yang, 1976).

Addition of AgNO<sub>3</sub> and AVG to the culture media has been shown to greatly improve in vitro plant regeneration of both dicot and monocot species. The use of silver thiosulphate (STS) and AVG increased the percentage of adventitious shoot regeneration from apricot leaf explants (Burgos and Albuquerque, 2003). Addition of AgNO<sub>3</sub> and AVG to culture media markedly enhanced the regeneration frequency and number of shoots obtained per explant in pomegranate (*Punica granatum* L.) (Naik and Chand, 2003). Addition of AgNO<sub>3</sub> to a callus induction medium was highly effective for shoot regeneration in three genotypes of rapeseed (*Brassica napus* L.) (Akasaka-Kennedy et al., 2005).

An efficient protocol for plant regeneration is essential to the practice of genetic engineering for plant improvement. In this study, we developed an improved method for regeneration of *E. angustifolia* using the ethylene inhibitors AgNO<sub>3</sub>, AVG, and CoCl<sub>2</sub>. These results will facilitate research on the genetic enhancement of *E. angustifolia*.

### Corresponding author:

Dr. Sang Un Park

Department of Crop Science, Chungnam National University, 79 Daehangno, Yuseong-Gu, Daejeon, 305-764, Korea

E-mail: supark@cnu.ac.kr

**Table 1.** Effect of different concentrations of ethylene inhibitors on shoot regeneration in *Echinacea angustifolia* after 6 weeks of culture on regeneration medium (Murashige and Skoog medium with 2.0 mg/L BAP).

Ethylene inhibitors*	Regeneration frequency**	Number of shoots per explant**	Shoot length <sup>a</sup>	
(mg L <sup>-1</sup> )	(%)		(cm)	
Control	0	72	3.1 ± 0.2	1.2 ± 0.1
AgNO <sub>3</sub>	1	75	3.3 ± 0.2	1.5 ± 0.1
	5	81	3.9 ± 0.2	1.7 ± 0.2
	10	89	4.5 ± 0.3	1.9 ± 0.2
	20	63	2.6 ± 0.1	1.0 ± 0.0
AVG	1	74	3.5 ± 0.3	1.3 ± 0.1
	5	79	3.8 ± 0.3	1.6 ± 0.2
	10	87	4.3 ± 0.4	1.8 ± 0.2
CoCl <sub>2</sub>	20	72	2.9 ± 0.1	1.1 ± 0.1
	1	74	3.4 ± 0.2	1.3 ± 0.2
	5	72	3.0 ± 0.2	1.3 ± 0.1
	10	65	2.7 ± 0.2	1.0 ± 0.0
	20	58	1.9 ± 0.1	0.7 ± 0.0

\* Basal medium consisted of Murashige and Skoog salts and vitamins, 30 g/L sucrose, and 2 mg/L BAP, solidified with 7 g/L Phytagar.

\*\* From 100 leaf explants tested.

<sup>a</sup> Values represent the mean ± standard deviation of 50 shoots

## References

1. Pepping J. Echinacea. Am J Health Syst Pharm. 1999;56:121-122.
2. Percival SS. Use of echinacea in medicine. Biochem Pharmacol. 2000;60:155-158.
3. Kindscher, K. Ethnobotany of purple coneflower (*Echinacea angustifolia*, Asteraceae) and other *Echinacea* species. Econ Bot. 1989;43:4498-507.
4. Barnes J, Anderson LA, Gibbons S, Phillipson JD. Echinacea species (*Echinacea angustifolia* (DC.) Hell., *Echinacea pallida* (Nutt.) Nutt., *Echinacea purpurea* (L.) Moench): a review of their chemistry, pharmacology and clinical properties. J Pharm Pharmacol. 2005;57: 929-954.
5. Brown DC, Thorpe TA. Plant regeneration by organogenesis. In: Vasil I.K. (ed) Cell Culture and Somatic Cell Genetics of Plants, Academic Press, New York, 1986;pp 49-65.
6. Thorpe TA. The current status of plant tissue culture. In: Bhojwani S.S. (ed) Plant tissue culture: Applications and limitations, Elsevier, Amsterdam, 1990;pp 1-33.
7. Yang SF, Hoffman NE. Ethylene biosynthesis and its regulation in higher plants. Ann. Rev. Plant Physiol. 1984;35:155-189.
8. Biddington N. The influence of ethylene in plant tissue culture. Plant growth regulation 1992;11(2):173-187.
9. Huang XL, Li XJ, Li Y, Huang LZ. The effect of AOA on ethylene and polyamine metabolism during early phases of somatic embryogenesis in *Medicago sativa*. Physiol Plant. 2001;113:424-429.
10. Jha AK, Dahleen LS, Suttle JC. Ethylene influences green plant regeneration from barley callus. Plant Cell Rep. 2007;26:285-290.
11. Chatfield SP, Raizada MN. Ethylene and shoot regeneration: hookless1 modulates de novo shoot organogenesis in *Arabidopsis thaliana*. Plant Cell Rep. 2008;27:655-666.
12. Chae SC, Kim HH, Park SU. Ethylene Inhibitors Enhance Shoot Organogenesis of Gloxinia (*Sinningia speciosa*). The Scientific World Journal. 2012, Article ID 859381
13. Park EH, Bae H, Park WT, Kim YB, Chae SC, Park SU. Improved shoot organogenesis of gloxinia (*Sinningia speciosa*) using silver nitrate and putrescine treatment. Plant Omics. 2012;5: 6-9.
14. Kumar PP, Lakshmanan P, Thorpe TA. Regulation of morphogenesis in plant tissue culture by ethylene. In Vitro Cell Dev Biol. 1998;34:94-103
15. Harbage JF. Micropropagation of *Echinacea angustifolia*, *E. pallida* and *E. purpurea* from stem and seed explants, HortScience 2001;36:360-364.

16. Lakshmanan P, Danesh M, Taji. Production of four commercially cultivated Echinacea species by different methods of *in vitro* regeneration, J. Hortic. Sci. Biotechnol. 2002;77:158-163.
17. Lucchesini M, Bertoli A, Mensuali-Sodi A, Pistelli A. Establishment of *in vitro* tissue cultures from *Echinacea angustifolia* D.C. adult plants for the production of phytochemical compounds. Scientia Horticulturae. 2009;122: 484-490.
18. Murashige T, Skoog F. A revised medium for rapid growth and bioassays with tobacco tissue cultures. Physiol. Plant. 1962;15:473-497.
19. Kim JS, Lee SY, Eom SH, Park SU. Improved shoot organogenesis and plant regeneration of *Echinacea angustifolia* DC. Journal of Medicinal Plants Research 2010;4:587-591.
20. Beyer EM. Effect of silver ion, carbon dioxide, and oxygen on ethylene action and metabolism. Plant Physiol. 1979;63:169-173.
21. Lau O, Yang SF. Inhibition of ethylene production by cobaltous ion. Plant Physiol. 1976;58: 114-117
22. Burgos L, Alburquerque N. Ethylene inhibitors and low kanamycin concentrations improve adventitious regeneration from apricot leaves. Plant Cell Rep. 2003;21:1167-1174.
23. Naik SK, Chand PK. Silver nitrate and aminoethoxyvinylglycine promote *in vitro* adventitious shoot regeneration of pomegranate (*Punica granatum* L.). J Plant Physiol. 2003;160:423-430.
24. Akasaka-Kennedy Y, Yoshida H, Takahata Y. Efficient plant regeneration from leaves of rapeseed (*Brassica napus* L.): the influence of AgNO<sub>3</sub> and genotype. Plant cell reports 2005;24:649-654.

9/6/2012

## Ab initio study of thermodynamic properties, IR spectra and electrical properties of $\text{Cu}_4\text{O}_3\text{H}_2$ nanosemiconductor

Elham Pournamdari<sup>1\*</sup>, Majid Monajjemi<sup>2</sup> and Karim Zare<sup>3</sup>

<sup>1</sup>Ph.D. Student, Department of Chemistry, Science and Research Branch, Islamic Azad University, Tehran, Iran

<sup>2</sup> Department of Chemistry, Science and Research Branch, Islamic Azad University, Tehran, Iran

<sup>3</sup> Department of Chemistry, Science and Research Branch, Islamic Azad University, Tehran, Iran

\*Corresponding author: epournamdar@yahoo.com

**Abstract.** Cupric oxide is a p-type semiconductor has received a considerable attention due to their interesting properties, such as high-temperature superconductors, optical switch and anode electrodes for batteries. In this theoretical study thermodynamic properties and hyperfine spectroscopic parameters of this novel compound are carried out within a density functional methods (B3LYP, B1LYP and B3P86) employing 6-31G+ (d) basis set. All calculations were performed using GAUSSIAN 98 packages of program. Thermodynamic properties of  $\text{Cu}_4\text{O}_3\text{H}_2$  nanocluster as well as IR data and spectra were obtained. In addition we are carrying out more detailed studies of the electronic and chemical properties of this compound such as HOMO and LUMO energies which have been used to explicate data regarding charge transfer within the molecule. HOMO and LUMO gap revealed that  $\text{Cu}_4\text{O}_3\text{H}_2$  has obvious delocalization, making it have good stability, high voltage differences and its semiconductors property. [Elham Pournamdari, Majid Monajjemi and Karim Zare. **Ab initio study of thermodynamic properties, IR spectra and electrical properties of  $\text{Cu}_4\text{O}_3\text{H}_2$  nanosemiconductor.** Life Sci J 2012;9(4):1729-1738] (ISSN:1097-8135). <http://www.lifesciencesite.com>. 264

**Keywords:** Ab initio, HOMO and LUMO, IR spectra, nanosemiconductor, Thermodynamic property, hyperfine spectroscopic parameters.

### 1 Introduction

Copper oxide ( $\text{CuO}$ ) is p-type narrow band gap semiconductor substances which have inimitable physical properties and great potential for various photonic and electronic applications that need superconductivity, colossal magnetoresistivity, and piezoelectricity.  $\text{CuO}$  has widespread usage in lithium–copper oxide electrochemical cells, magnetic storage media, gas sensor, solar energy transformations, etc. Due to unique physical and electronic properties, [1–4]  $\text{CuO}$  Nanoscale materials have received a great significant attention in recent years both experimentally and theoretically as long as some new characteristics have been explored for them which are different from the bulk materials. For example, UV–visible absorption spectrum studies reveal that  $\text{CuO}$  band gap in bulk ( $E_g = 1.85$  eV) is much smaller than that in nanoparticles  $\text{CuO}$  ( $E_g = 2.18$  eV) [5]. Therefore, different morphologies with and without using surfactants or templates have been gained for the  $\text{CuO}$ , such as nanorods [6], nanowires [7, 8], nanowhiskers [9], nanoplatelets [10–12], nanoribbons [13, 14], feather-like [15], urchin-like

[16, 17], and plates-like [18].  $\text{CuO}$  has been prepared by different synthetic methods such as hydrothermal [19–23], hydrothermal reduction [24], simple solution [25, 26], simple hydrolysis [27], self-catalytic mechanism [28], solvothermal [29] microwave heating using ionic liquids [30] and microwave irradiation [31]. However studies about  $\text{CuO}$  nanosemiconductor are still limited and it has been a serious problem to obtain single crystals of  $\text{CuO}$  suitable for quantitative infrared studies. Therefore theoretical investigation on these systems has been extensively used. In this theoretical research Vibrational studies as well as NBO analysis combined with ab initio and we have been reported an ab initio-based numerical method of obtaining infrared spectroscopic data for  $\text{Cu}_4\text{O}_3\text{H}_2$  molecules that allows calculation of complete IR data, IR spectra and thermodynamic properties of this system. In the present paper, by using quantum methods the structure, stability, and electrical dipole moments of  $\text{Cu}_4\text{O}_3\text{H}_2$  molecules have been investigated.

### 2 Calculation method

DFT calculations were done using the B3LYP, B1LYP and B3P86 functionals for studying

thermodynamic properties, IR data and NBO analysis. The first job for the computational work was to reveal the optimized geometry of the compound. Molecular structure of  $\text{Cu}_4\text{O}_3\text{H}_2$  was optimized using B3LYP model with 6-31G (d) basis set. The B3LYP density functional model indicates good performance on electron affinities, vibrational frequencies, bond energies and geometries of inorganic compounds [32]. It is well known that in the quantum chemical literature the hybrid B3LYP [33, 34] method based on Becke's three parameter functional of density functional theory (DFT) yields a good description of harmonic vibrational wavenumbers for small and medium sized molecules [35]. Another factor which causes to choose the DFT methods is their capability to reproduce geometries and dipole moments of these molecules with quite high accuracy. All calculations were performed using the Gaussian 98 program package. The optimized geometric Structure of  $\text{Cu}_4\text{O}_3\text{H}_2$  with Cs symmetry is shown in Fig.1.

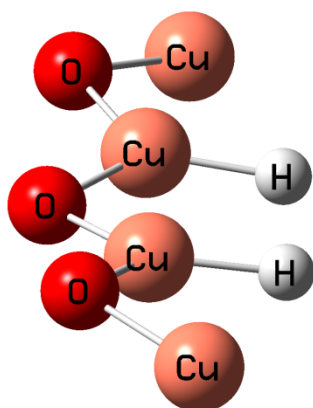

**Figure1** Geometry optimized (6-31G+ (d)) structures for  $\text{Cu}_4\text{O}_3\text{H}_2$  nanosemiconductor.

### 3 Results and Discussion

#### 3.1 Thermodynamic properties

The energies and thermo chemical parameters can give valuable information about structures and relative stabilities of these systems. The relative stability, relative energy  $\Delta(\Delta E)$ , enthalpy  $\Delta(\Delta H)$ , Gibbs free energy  $\Delta(\Delta G)$  and entropies (S) of  $\text{Cu}_4\text{O}_3\text{H}_2$  nanosemiconductor are computed in DFT methods using B3LYP, B1LYP and B3P86 levels of theory and comparison of these different levels with 6-31G (d) basis set are listed in table 1. Since the Gibbs free energy controlling the structure stability by analyzing the data from Table 1, we have found that Gibbs free energy  $\Delta(\Delta G)$  in B3P86 method is more negative than those of the other two methods. The entire trend observed for enthalpy  $\Delta(\Delta H)$  and thermal energy  $\Delta(\Delta E)$  which can be seen in Table 1 and fig. 1 though B3P86 shows the best results for  $\text{Cu}_4\text{O}_3\text{H}_2$  systems among these methods for this structure stability at the point of thermodynamic properties. This effect is probably due to the large dipole moments of the Cu-O bonds, which preferentially enhance the structures stability. These results suggest that for a given increase of the dipole moment there is certain degree of stabilization.

**Table1** Relative thermodynamic data for  $\text{Cu}_4\text{O}_3\text{H}_2$  system in kcal/mol and antropy in cal/mol.kelvin

Basis set		6-31G+(d)			
Method	E(scf)	$\Delta(\Delta E)$	$\Delta(\Delta H)$	$\Delta(\Delta G)$	S
B3LYP	3.01	-1874.67	-1881.25	-1883.32	109.06
B1LYP	3.23	-2021.45	-2021.45	-2020.40	119.50
B3P86	0.00	0.00	0.00	0.00	116.00

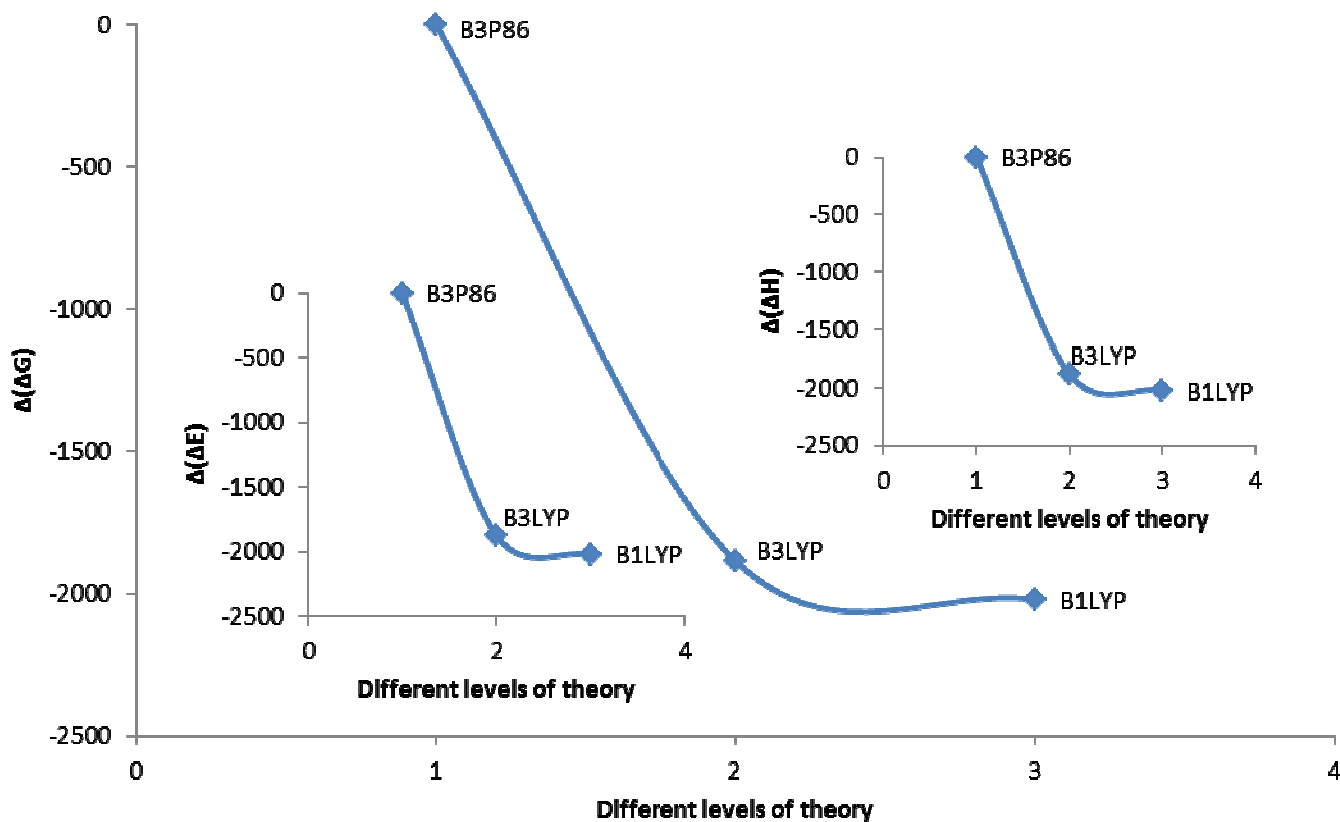

**Figure 2** Different levels of theory as a function of  $\Delta(\Delta G)$ ,  $\Delta(\Delta H)$ ,  $\Delta(\Delta E)$  in kcal/mol in  $\text{Cu}_4\text{O}_3\text{H}_2$  structure.

### 3.2 IR spectroscopy

Vibrational spectroscopy (infrared spectroscopy) has been recognized as an important tool for the characterization and understanding of molecular structures and dynamics for a long time [36]. DFT method yield very accurate infrared spectra of inorganic molecules in terms of band positions, band shapes, and band intensities [37, 38]. Absorption intensities and vibrational spectra serve as “fingerprints” to identify a known molecule, or determine the geometry of one that has not been defined before. Infrared measurements are generally complemented with theoretical calculations. These are usually carried out using quantum chemistry calculations where equilibrium conformations of lowest energies are calculated. In this work, geometry optimizations are implemented, and vibrational analyses are subsequently done for this structure. There have been efforts to carry out a detailed analysis of the vibrations based on vibrational spectroscopy data for  $\text{Cu}_4\text{O}_3\text{H}_2$  molecules [8]. The studied compound

consists of 9 atoms, and so it has 21 normal vibrational modes. The numerical harmonic vibrational analysis was done for the optimized geometry, the absence of negative frequencies emphasizing that this structure correspond to real minimum which emphasized structural stability. We describe DFT numerical method of obtaining infrared spectroscopic data of  $\text{Cu}_4\text{O}_3\text{H}_2$  molecules that allows calculation of complete sets of Vibrational modes, frequency and IR intensity which are calculated with B3LYP, B1LYP and B3P86 methods using 6-31G (d) basis sets that are represented in table 2 and comparison between them can be seen and IR spectrum of this nanocluster shown in figure 3, 4 and 5 for B3LYP, B1LYP and B3P86 methods of density functional theory (DFT), respectively. In each of three IR spectrums which are calculated with DFT methods 2 sharp frequency modes with high intensities could be observed. As can be seen in table 2 the maximum intensity in B3LYP levels of theory is at frequencies of  $542.16\text{ cm}^{-1}$  with 367.94 intensities,

for B1LYP is at frequencies of  $548.89 \text{ cm}^{-1}$  with 469.71 intensities and for B3P86 levels of theory is at frequencies of  $540.55 \text{ cm}^{-1}$  with 362.87 intensities which are shown that there is a slightly increase in intensity for B1LYP methods in comparison of B3LYP and B3P86 levels of theory. These three frequencies are the strongest signals in  $\text{Cu}_4\text{O}_3\text{H}_2$  molecules. Obviously, the low intensity mode for B3LYP levels of theory is at  $142.88 \text{ cm}^{-1}$  with 0.05 intensities, for B1LYP levels of theory is at frequencies of  $150.56 \text{ cm}^{-1}$  with 0.30 intensities

and for B3P86 levels of theory is at frequencies of  $158.91 \text{ cm}^{-1}$  with 0.42 intensities in spectrum of  $\text{Cu}_4\text{O}_3\text{H}_2$  molecules is the A' mode in all three levels of theory. B3P86 method has largest blue shift in comparison of B3LYP and B1LYP levels of theory which implies different applications of this novel nanosemiconductor molecule. The present spectroscopic analysis shows that all DFT methods have nearly identical spectral characteristics and they are in good agreement with each other's.



Table 1 Vibrational mode, harmonic frequency ( $\text{cm}^{-1}$ ) and IR intensity (KM/Mole) with B3LYP, B1LYP and B3P86 with 6-31G+ (d) basis set.

Basis set	6-31G(d)							
	B3LYP	IR intensity	B1LYP	B3P86				
Vibrational modes	Frequency		Vibrational modes	Frequency	IR intensity	Vibrational modes	Frequency	IR intensity
A'	755.54	5.14	A'	717.76	3.38	A'	762.75	4.43
A"	542.16	367.94	A"	548.89	469.71	A"	540.55	362.87
A'	87.33	12.04	A'	26.3211	1.55	A'	24.35	0.71
A'	26.77	1.43	A"	37.08	4.05	A"	6.15	7.53
A'	54.75	3.49	A'	57.28	3.49	A'	65.25	2.26
A'	63.27	2.47	A'	65.22	1.879	A'	67.89	1.85
A"	71.61	7.03	A"	69.85	7.62	A"	76.59	8.30
A'	81.62	97.37	A'	82.62	5.29	A'	99.08	7.38
A"	97.37	2.68	A"	103.51	3.37	A"	106.38	2.50
A"	122.07	0.50	A"	145.16	3.03	A"	145.84	3.17
A'	142.88	0.05	A'	150.56	0.30	A'	158.91	0.42
A"	191.70	2.34	A"	209.11	5.87	A"	211.30	4.80
A'	226.08	23.25	A'	250.92	27.51	A'	256.14	22.94
A'	400.14	38.53	A'	401.12	38.10	A'	398.31	38.69
A"	443.21	14.01	A"	444.81	14.10	A"	439.90	15.19
A'	473.34	5.08	A'	475.38	5.384	A'	468.35	5.36
A"	588.18	271.16	A"	592.21	311.19	A"	579.53	275.06
A'	598.45	4.04	A'	603.19	4.30	A'	590.24	4.31
A"	648.66	232.31	A"	653.90	235.90	A"	640.46	219.23
A'	1893.12	19.60	A'	1892.95	23.79	A'	1886.80	17.45
A"	1894.64	9.48	A"	1893.15	12.72	A"	1889.94	10.92

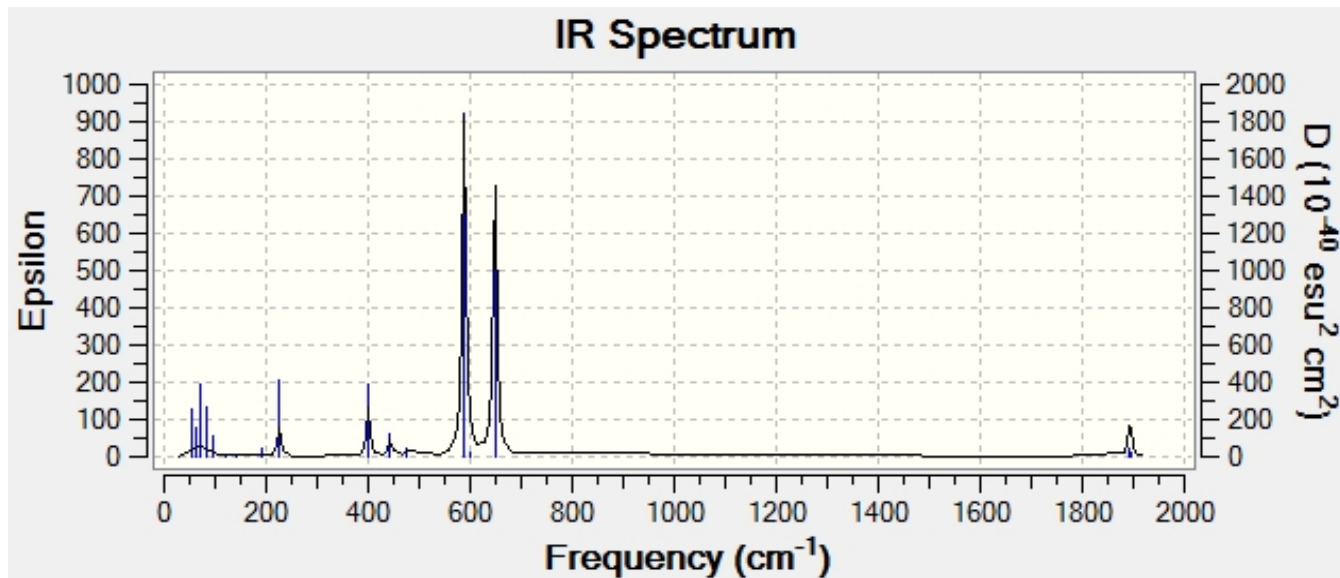

Figure 3 IR spectrum of  $\text{Cu}_4\text{O}_3\text{H}_2$  system obtained from B3LYP/6-31G+ (d) methods.

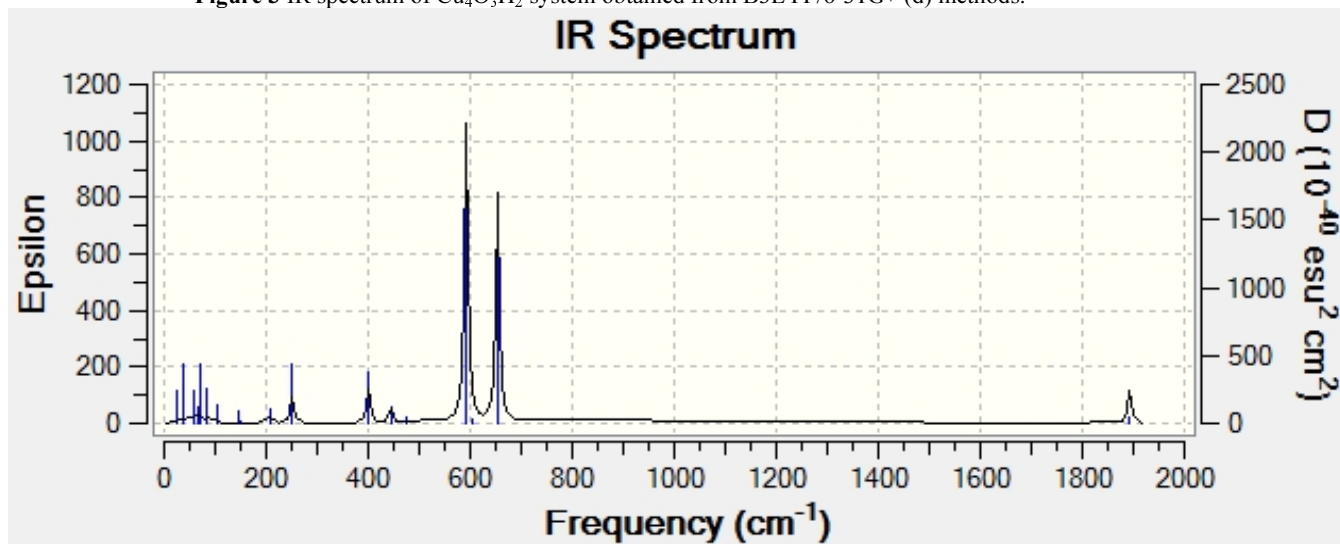

Figure 4 IR spectrum of  $\text{Cu}_4\text{O}_3\text{H}_2$  system obtained from B1LYP/6-31G+ (d) methods.

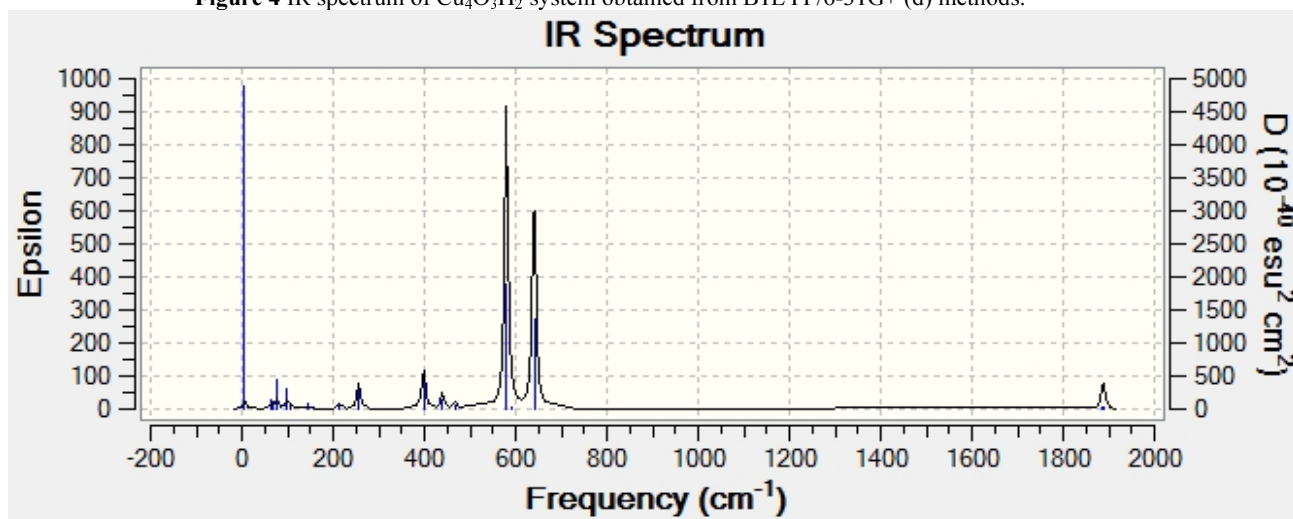

Figure 5 IR spectrum of  $\text{Cu}_4\text{O}_3\text{H}_2$  system obtained from B3P86/6-31G+ (d) methods.

### 3.3 HOMO-LUMO Gap of the System

The HOMO-LUMO band gap is a gap between the LUMO (the lowest unoccupied molecular orbital) and HOMO (the highest occupied molecular orbital). The large LUMO-HOMO gap is often concerned as a molecule stability condition [39]. Both (LUMO) and (HOMO) are the main orbital accompanied in chemical reaction. The HOMO energy describes the ability of electron giving, LUMO describes the ability of electron accepting, and the gap between them describes the molecular chemical stability [40]. A critical parameter in determining molecular electrical transport property is the energy gap between the highest occupied and

the lowest unoccupied molecular orbitals, because it shows a measure of electron conductivity. Table 2 represented the band gap and dipole moment of  $\text{Cu}_4\text{O}_3\text{H}_2$  molecule which are calculated in B3LYP, B1LYP and B3P86 levels of DFT theory. According to table 2 the obtained result for B3LYP levels of theory are in good agreement with reported experimental values [5]. Moreover, it could be observed that between B3LYP, B1LYP and B3P86 the largest band gap energy calculated for B3P86 levels of theory which caused the blue shift for  $\text{Cu}_4\text{O}_3\text{H}_2$  nanosemiconductors molecule and the highest stability for this structure.

**Table 2.** Band gap in eV and dipole moment in Debye for  $\text{Cu}_4\text{O}_3\text{H}_2$  molecule at different levels of theory with 6/31G+ (d) basis set.

Basis set	6-31G+(d)	
Method	band gap (HOMO-LUMO) (eV)	Dipole moment (Debye)
B3LYP	2.28	8.67
B1LYP	2.76	8.85
B3P86	2.32	8.82

### 3.4 Hyperfine spectroscopic parameters

Total atomic charge, electric potential, total atomic spin densities and voltage difference (a.u) at B3LYP, B1LYP, LSDA, B3P86 and B3PW91 levels of theory have been done and the results have been performed in table 3. As can be seen from table 3 and figure 6, Cu atoms has positive and oxygen has negative charge and the same trend have been found for all these levels of theory and all of them are in agreement with each other. Figure 7 represented Voltage of each atom versus atomic charge of  $\text{Cu}_4\text{O}_3\text{H}_2$  molecule. Moreover, Voltage difference of this novel structure for each bond has been reported and maximum and minimum picks have been observed for all these levels of theory which performed that also they shows similar trend. The consequence exhibited electrical current go through all the atoms in the structure and the effluvium is not invariable and steady which emphasized the applications of this structure as a semiconductor.

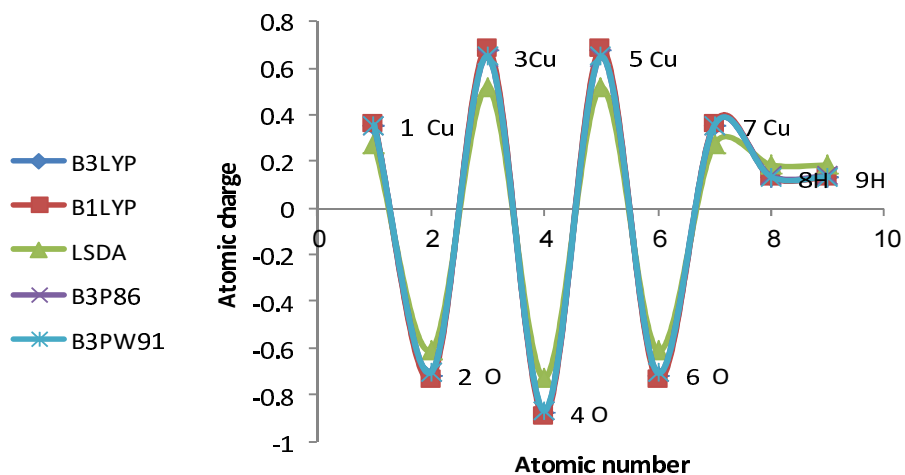

**Figure 6** Atomic charges (a.u) of  $\text{Cu}_4\text{O}_3\text{H}_2$  system as a function of atomic number at different levels of theory with 6-31G+ (d) basis set.

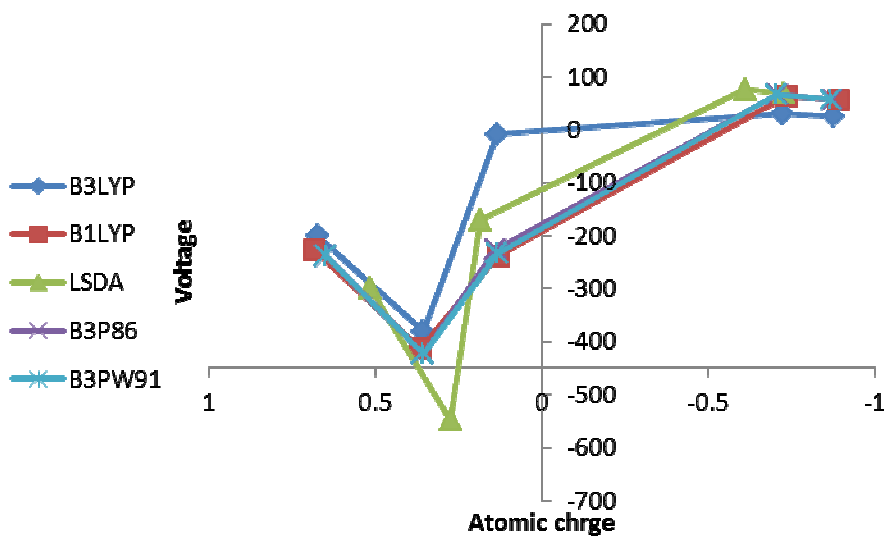

**Figure 7** Voltage of  $\text{Cu}_4\text{O}_3\text{H}_2$  systems as a function of atomic charge at different levels of theory with 6-31G+ (d) basis set.

**Table 3.** Total atomic charge (a. u), Electrical potential (a. u), total atomic spin densities and voltage difference (a. u) of Cu<sub>4</sub>O<sub>3</sub>H<sub>2</sub> molecule with EPR=6/31G+d at different levels of DFT theory.

Method	Total atomic charges	Electric potential	EPR=6-31G+d			Total atomic spin densities	Total atomic charges	Electric potential	LSDA			
			$ \Delta V = V_2 - V_1 $	Total atomic spin densities	Total atomic charges				$ \Delta V = V_2 - V_1 $	Total atomic spin densities		
1 Cu	0.36	-135.23	410.97	3.58	0.36	-150.76	477.12	3.58	0.27	-150.68	625.72	1.89
2 O	-0.72	-22.33	→	3.51	-0.74	-46.87	→	3.51	-0.61	-46.80	→	1.87
3 Cu	0.67	-135.21	226.41	1.83	0.69	-154.78	281.81	1.83	0.52	-154.71	368.38	1.35
4 O	-0.88	-22.35	→	1.31	-0.89	-50.00	→	1.31	-0.73	-49.91	→	1.14
5 Cu	0.67	-135.21	231.85	1.83	0.69	-154.78	289.61	1.83	0.52	-154.71	376.52	1.35
6 O	-0.72	-22.33	→	3.51	-0.74	-46.87	→	3.51	-0.61	-46.80	→	1.87
7 Cu	0.36	-135.23	372.45	3.58	0.36	-150.76	175.92	3.58	0.27	-150.68	379.23	1.89
8 H	0.13	-1.02	→	1.87	0.13	-31.35	→	1.87	0.18	-31.32	→	1.37
9 H	0.13	-1.02	372.45	1.87	0.13	-31.35	175.92	1.87	0.18	-31.32	379.23	1.37
<b>Method</b>		<b>B3LYP</b> →				<b>B3LYP</b> →				<b>LSDA</b> →		
1 Cu	0.36	-150.76	489.28	3.58	0.36	-150.76	489.60	1.89	-	-	-	-
2 O	-0.71	-46.86	→	3.51	-0.71	-46.86	→	1.87	-	-	-	-
3 Cu	0.65	-154.79	296.07	1.83	0.65	-154.79	295.62	1.35	-	-	-	-
4 O	-0.87	-49.99	→	1.31	-0.87	-49.99	→	1.14	-	-	-	-
5 Cu	0.65	-154.79	305.03	1.83	0.65	-154.79	304.42	1.35	-	-	-	-
6 O	-0.71	-46.86	→	3.51	-0.71	-46.86	→	1.87	-	-	-	-
7 Cu	0.36	-150.76	196.72	3.58	0.36	-150.76	188.68	1.89	-	-	-	-
8 H	0.14	-31.35	→	1.87	0.13	-31.35	→	1.37	-	-	-	-
9 H	0.14	-31.35	196.72	1.87	0.13	-31.35	188.68	1.37	-	-	-	-

## Conclusion

In this paper we have been calculated thermodynamic properties, HOMO- LUMO gap which have shown molecular electrical transport property, dipole moment, vibrational frequencies, IR intensities and IR spectra of  $\text{Cu}_4\text{O}_3\text{H}_2$  molecule with B3LYP, B1LYP and B3P86 levels of DFT theory and comparison between them have been done. The obtained results confirmed that these levels are in good agreement with each other's and implies this novel structure as a new semiconductor system. Comparison between theoretical and experimental result [5] indicant hybrid functional theory are capable of performing reliable molecular properties.

## References

- [1] P. Poizot, S. Laruelle, S. Grugeon, L. Dupont, J.M. Taracón, Nano-sized transition-metal oxides as negative-electrode materials for lithium-ion batteries, *Nature*, 407,496-499, (2000)
- [2] X.P. Gao, J.L. Bao, G.L. Pan, H.Y. Zhu, P.X. Huang, F. Wu, D.Y. Song, Preparation and Electrochemical Performance of Polycrystalline and Single Crystalline CuO Nanorods as Anode Materials for Li Ion Battery, *J. Phys. Chem. B* 108(18), 5547-5551 (2004).
- [3] R.V. Kumar, Y. Diamant, A. Gedanken, Chem. Mater, Sonochemical synthesis and characterization of nanometer-size transition metal oxides from metal acetates, *J. Phys. Chem. B* 105(20), 2301-2305(2001).
- [4] T. Maruyama, *Sol. Energy Mater. Sol. Cells* 56 (1998) 85.
- [5] Yu Dongliang, Ge Chuannan and Du Youwei, Preparation and characterization of CuO nanowire arrays, *J. Semiconductors* Vol. 30, No. 7 072003-1, 2009.
- [6] W.-T. Yao, S.-H. Yu, Y. Zhou, J. Jiang, Q.-S. Wu, L. Zhang, *J. Phys. Chem. B* 109 (2005) 14011.
- [7] Y.-K. Su, C.-M. Shen, H.-T. Yang, H.-L. Li, H.-J. Gao, *Trans. Nonferrous Met. Soc. China* 17,783-786 (2007).
- [8] J.T. Chen, F. Zhang, J. Wang, G.A. Zhang, B.B. Miao, X.Y. Fan, D. Yan, P.X. Yan, *J. Alloys Compd.* 454, 268-273 (2008).
- [9] Y. Qu, X. Li, G. Chen, H. Zhang, Y. Chen, synthesis of Cu<sub>2</sub>O nano-whiskers by a novel wet-chemical route, *J. Mater. Lett.* 62, 886-888 (2008).
- [10] Y. Liu, Y. Chu, M. Li, L. Li, L. Dong, *J. Mater. Chem.* 16, 192-198 (2006).
- [11] M. Vaseem, A. Umar, Y.B. Hahn, D.H. Kim, K.S. Lee, J.S. Jang, *Catalysis Commun.* 10 (2008) 11.
- [12] D.P. Volanti, D. Keyson, L.S. Cavalcante, A.Z. Simões, M.R. Joya, E. Longo, J.A. Varela, P.S. Pizani, A.G. Souza, *J. Alloys Compd.* 459 (2008) 537.
- [13] C.L. Zhu, C.N. Chen, L.Y. Hao, Y. Hu, Z.Y. Chen, *J. Cryst. Growth* 263 (2004) 473.
- [14] X. Gou, G. Wang, J. Yang, J. Park, D. Wexler, *J. Mater. Chem.* 18 (2008) 965-969.
- [15] H. Zhang, M. Zhang, *Mater. Chem. Phys.* 108 (2008) 184.
- [16] M. Vaseem, A. Umar, S.H. Kim, A. Al-Hajry, Y.B. Hahn, Growth and structural properties of urchin-like CuO structures composed of thin CuO nanosheets prepared by simple solution process *Mater. Lett.* 62, 1659-1662 (2008).
- [17] D. Keyson, D.P. Volanti, L.S. Cavalcante, A.Z. Simões, J.A. Varela, E. Longo, *Mater. Res. Bull.* 43 (2008) 771.
- [18] Y. Li, J. Liang, Z. Tao, J. Chen, *Mater. Res. Bull.* 43 (2008) 2380.
- [19] F. Teng, W. Yao, Y. Zheng, Y. Ma, Y. Teng, T. Xu, S. Liang, Y. Zhu, *Sens. Synthesis of flower-like CuO nanostructures as a sensitive sensor for catalysis Actuators B: Chem.* 134, 761-768 (2008).
- [20] Z.-Z. Chen, E.-W. Shi, Y.-Q. Zheng, W.-J. Li, B. Xiao, J.-Y. Zhuang, *J. Cryst. Growth* 249 (2003) 294.
- [21] H. Zhang, S. Li, X. Ma, D. Yang, *Mater. Res. Bull.* 43 (2008) 1291.
- [22] M. Zhang, X. Xu, M. Zhang, Hydrothermal synthesis of sheaf-like CuO via ionic liquids *Mater. Lett.* 62, 385-388, (2008).
- [23] M.-G. Ma, Y.-J. Zhu, Hydrothermal synthesis of cuprous oxide microstructures assembled from needles *J. Alloys Compd.*, 455, L15-L18 (2008).
- [24] X. Zhang, G. Wang, X. Liu, H. Wu, *Mater. Chem. Phys.* 112 (2008) 726.
- [25] L. Yu, G. Zhang, Y. Wu, X. Bai, D. Guo, *J. Cryst. Growth* 310 (2008) 3125.
- [26] S.F. Zheng, J.S. Hu, L.S. Zhong, W.G. Song, L.J. Wan, Y.G. Guo, Introducing Dual Functional CNT Networks into CuO Nanomicrospheres toward Superior Electrode Materials for Lithium-Ion Batteries, *Chem. Mater.* 20, 3617-3622 (2008).
- [27] J. Zhu, H. Bi, Y. Wang, X. Wang, X. Yang, L. Lu, Synthesis of flower-like CuO nanostructures via a simple hydrolysis route, *Mater. Lett.* 6, 5236-5238 (2007).
- [28] C.T. Hsieh, J.M. Chen, H.H. Lin, H.C. Shih, *Appl. Phys. Lett.* 82, 3316-3318 (2003).
- [29] X.-L. Tang, L. Ren, L.-N. Sun, W.-G. Tian, M.-H. Cao, C.-W. Hu, *Chem. Res. Chinese U* 22 (2006) 547.
- [30] X. Xu, M. Zhang, J. Feng, M. Zhang, *Mater. Lett.* 62, 2787-2790 (2008).
- [31] H. Wang, J.Z. Xu, J.-J. Zhu, H.-Y. Chen, Preparation of CuO nanoparticles by microwave irradiation, *J. Cryst. Growth* 244, 88-94 (2002).
- [32] Check C.E., Faust T.O., Bailey J.M., Wright B.J., Gilbert T.M., Sunderlin L.S., Addition of polarization and diffuse functions to the LanL2dz basis set for P-block elements, *Journal of Physical Chemistry A*, 105 (34), 8111-8116 (2001).
- [33] Becke AD *J Chem Phys* 98:5648(1993)
- [34] Lee C, Yang W, Parr RG, *Phys Rev B* 37:785-789, (1988).
- [35] Rauhut G, Pulay P, Transferable Scaling Factors for Density Functional Derived Vibrational Force Fields, *J Phys Chem* 99:3093-3100, (1995).
- [36] D. C. Marinica, G. Gre'goire, C. Desfranc'ois, J. P. Schermann, D. Borgis and M. P. Gaigeot, Ab initio molecular dynamics of protonated dialanine and comparison to infrared multiphoton dissociation experiments, *J. Phys. Chem. A* 2006, 110, 8802-8810.
- [37] Gaigeot, M.-P.; Sprik, M, Ab initio molecular dynamics computation of the infrared spectrum of aqueous uracil, *J. Phys. Chem. B*, 107, 10344-10358 (2003).
- [38] Gaigeot, M.-P. Vuilleumier, R.; Sprik, M.; Borgis, D, *Infrared spectroscopy of N-methyl-acetamide revisited by ab initio molecular dynamics simulations*, *J. Chem. Theor. Comput.* 2005, 1, 772.
- [39] M. Monajjemi, V. S. Lee, M. Khaleghian, B. Honarparvar, and F. Mollaamin
- [40] Fukui K, Role of Frontier Orbitals in Chemical-Reactions, *Science*, 218,747-754(1982).

10/23/2012

**Analysis of Totemic Cow and its Association with the Fereydoun Family in Ferdowsi's Shahnameh**Masoumeh Zandie<sup>1</sup>, Kheironnesa Mohammadpour<sup>2\*</sup> and Nahid Sharifi<sup>3</sup><sup>1</sup> Department of Persian Literature, Payame-Nour University, Iran  
E-mail: Zandieh436@gmail.com<sup>2</sup> Department of Persian Literature, Payame-Nour University, Iran  
E-mail: nmohamadpour@yahoo.com<sup>3</sup> Department of English Literature, Payame-Nour University, Iran  
\*Corresponding author: nmohamadpour@yahoo.com

**Abstract:** The origin and source of national epics are old oral tales that are conveyed to the future generations and also are recorded in epic works. Hence, these works reflect the thoughts, ideas, and rituals of the nation they belong. Moreover, since totem and totemism is an old ritual that dates back to the distant past of most of the nations, it is reflected in the form of epic. This paper particularly deals with the manifestation and embodiment of totemic cow in the Shahnameh and its association with Fereydoun's Family.

[Masoumeh Zandie, Kheironnesa Mohammadpour and Nahid Sharifi. **Analysis of Totemic Cow and its Association with the Fereydoun Family in Ferdowsi's Shahnameh.** *Life Sci J* 2012;9(4):1739-1747] (ISSN:1097-8135).  
<http://www.lifesciencesite.com>. 265

**Keywords:** Totemism, Totem, the Shahnameh, Fereydoun, Cow

**Introduction**

Totem and totemism is discussed in books on the history of religions (including *A History of the World's Religions* by John Boyer Noss). Claude Levi Strauss, the French intellectual, wrote a book titled *Le Totemisme aujourd'hui* (Totemism, 1963). Of course, the works of this great scientist are difficult to understand due to his ignoring the ability and understanding of different classes of the society that are the audience of such topics. In addition, Sigmund Freud's *Totem and Taboo* (1918) also studies the traces of totemism in the fields of psychology and anthropology with regard to the habits, customs, and beliefs of Arab and Jewish Semitic families and tribes and many different tribes in ancient Africa, America, and Europe. Mircea Eliade and Carl Gustav Jung discussed totem and totemism in their many works and theorized about these matters as well. Among Iranian scholars, Dr. Mehrdad Bahar and Muhammad Jafar Yahaqi have also occasionally referred to family totems of some of the mythical figures of the Shahnameh.

This research is conducted by the library method and the results are presented in a descriptive-analytic way. Therefore, after discussing totem and its origin and providing the related definitions and characteristics, totemic cow and its manifestation in the story of Fereydoun in the Shahnameh is studied.

The word *Totem* is derived from the language of Indian tribes because these tribes considered animals as their ancestors and the exclusive god of their tribes and thus cherished their god and refused to eat it (Qarashi, 2001: 70). "In fact, worshiping and honoring animals and plants in some old nations have led to the creation of totemism." (Qadyani, 1995: 31) It should also be

mentioned that "In mythology, god is often embodied in the form of a certain animal" (Freud, 1976: 302).

Based on the definition of totem, "in totemism, all the tribesmen respect and put belief in some animals and plants and consider the spirit of that particular animal as their special protector. Totem refers to an honored object. For the totem was an animal of which they were afraid because of its power and rigor. Similarly, anthropologists also use the word Totemism for the worship of objects. The primitive tribes considered their totems as their godfather. Sometimes the tribal people tattoo the sign of their totem on their bodies because they think the attributes of the totem is transferred to them. Therefore, tribesmen considered themselves and also the totem worshiped by their tribes as humans. They sometimes appear in the form of their particular totem..." (Samadi, 1988: 13, 14).

Therefore, in general it can be said that: "Totem is first of all the ancestors of a group, and also a guardian and benefactor spirit that sends his messages through revelation. Furthermore, though it is dangerous to other people, it knows it offspring and does not harm them." (Freud, 1976: 7)

Felicien Challaye believes that "in most communities, the child inherits the name of the totem from his mother" (Challaye, 1976:12). However, according to Freud "totem is inherited from both parents" (Freud, 1976: 7). Furthermore, "totem is a slogan that is considered as the sign of the lineage of a group. Sometimes they draw this slogan on the ground, or on a shield, a tent or a house. The sign of totem is usually tattooed on man's body...Totemic images are more scared than the totems themselves. The sanctity of totem and its images is transferred to human beings. The reason for the sanctity of the person is that primitive

mankind believed that while he is literally human, he is also an animal and sometimes a part of the totem and thus he derives its name as well. Therefore, similarity of the names brings about similarity of natures...” (Challaye, 1976: 12).

In 1900, Ronak divided the laws of totemic religion into 12 general verdicts. The summary of these verdicts is as follows:

- Killing and eating some types of animals is forbidden. Human beings raise these types of animals and take care of them.
- Sudden death of an animal requires mourning. The body of the dead animal shall be buried with the respect similar to the burial of human beings.
- In some cases, only a special part of the body of the animal is not consumed.
- If there is a necessity for killing a religiously illegal animal, people will apologize to the animal and try to mitigate the negative results of killing it by taking different measures and procedures.
- When an animal is sacrificed based on the regulations, a formal ceremony will be held for him.
- In some formal occasions, during religious rituals people wear the skin of some of the animals. Peoples that still follow totemism use the skin of their totem for these ends.
- Tribes and people name themselves after the name of totemic animals.
- For many tribes the images of animals denote certain signs by which they decorate their weapons. Men draw animal figures on their bodies and tattoo the figures in order to print them permanently.
- According to their beliefs, if the totemic animal is dangerous and dreadful, it will not harm the members of the tribe that is named after it.
- The totemic animal will support and protect the tribesmen.
- The totemic animal informs the tribe of the future events and guides them as well.
- Members of a totemist tribe often feel kinship with the totemic animal (Freud, 1976: 137-139).

According to all the sources and works that have discussed this topic, one of the principal rules of totemism is the prohibition of killing the totemic animal (Palmer, 2006: 39).

Totemism or at least its impacts can be observed in the history of ancient Iran. In accord with Iranian narratives, Kai Khosrow and Ardeshir were fostered by a female dog and a goat, respectively. Achaemenid was also raised by an eagle (Azadegan, 1993:71). Even some examples of plant totemism can be found in Iranian mythology: some dynasties were thought to have kinship with some types of plants. That is to say, a special plant (tree or bush) was considered as the ancestor of a dynasty. Mandrake is a mythical plant that is considered as a typical example of plant totems.

When death came up to Keyumars, he fell on his left side and his semen fell to the ground. The semen was then purged and purified by the sunlight. After forty years, Mashya and Mashyana grew out of Keyumars' semen and formed a plant named rhubarb. At the beginning, Mashya and Mashyana were so twisted together that their arms were hung around their shoulders and their bodies were stuck together. Then spirit was blown into them and they took the form of human beings (Yahaqi, 1996:393). Mehrdad Bahar believes that rhubarb had been the tribal totem of primitive Iranians (Bahar, 2002: 29).

Therefore it can be concluded that traces of totemism can be seen in Iranian culture. Now we are going to see to what extent this ritual is manifested in the Shahnameh, which is a precious historical document that clarifies important historical and pre-historical events and the life of primitive Iranians.

### Cow

In Indo-European languages the word *Geo* refers to earth, life, and existence. Various Persian words of today such as *Gaav* (cow; Persian: گاو), *Giah* (plant; Persian: گیاه), *Gan* (Persian: گان), *Gian* (Persian: گیان), *Jaan* (life; Persian: جان), *Geyhan* (universe; Persian: گیهان) and *Jahan* (world; Persian: جهان) are derived from this word (Qarashi, 2001: 22). Even the root of the word Keyumars, which was originally an Avestan name (Gayyamartan; mortal live) and then a Pahlavi name (Gayomart), is derived from this word (Yahaqi, 1996: 122). In addition, “in the Avesta the word Gav/Gava (Persian: گاو) is the nickname of Sogdiana. In the first Fargard and Nadidad the name of Sogdiana is mentioned along the names of 16 countries created by Ahura Mazda (God). Charles-Joseph de Harlez<sup>1</sup> believes that Geo was the capital of Sogdiana. In any case, this word had been a sacred and ritual nickname meaning development, blessing, and life (Qarashi, 2001: 138, 139). In the ancient India the name Gotar (i.e., superior cow) had been a popular name (Qarashi, 2001: 95). According to this book, this word has other meanings in Sanskrit. One of its meanings is “militant”, which is of course written as *Gavista*, a part of which contains the word Gav (i.e., cow) (Qarashi, 2001: 211).

In ancient pre-Zoroastrian Iran, the moon (who illuminates the dark night) was always worshiped, because the Aryans residing in this land believed in many gods and worshiped elements of nature. According to the oldest potteries that are discovered, antelope, stag, and rabbit are three animals that belong to the moon. After awhile, the cow was considered by Iranians as the symbol of the moon (Samadi, 1988: 20, 21). Later, as the importance of the sun increased, cow and hog (that belonged to the moon) were known to be

<sup>1</sup> Belgian orientalist and translator of Avesta.



the animals of the sun. Phyllis Ackerman<sup>1</sup> considers the following rule as the characteristic of some civilizations (including totemic civilizations): the dominant owns the beaten (totems) (Samadi, 1988: 21).

While having its general meaning in the Avesta, this word appears as a common noun that refers to the livestock. In Zoroastrian culture the word cow is still used to refer to a class of animals including bufflehead (Persian: گاو میش), hog (Persian: گاوگراز), and grampus (Persian: گاو ماهی). In modern Persian language, the word sheep (Persian: گوسفند) that refers to both ewe and ox had been originally *Geospand* (meaning sacred cow). Cow is an extremely respectable animal in Mazdaism. They seek help from the guardian angel of the cow and refer to the fourteenth day of the month as Gooshrooz. Maybe this is the reason for the prohibition of sacrificing cows in religious rituals mentioned in the Gathas (Yahaqi, 1996: 360).

In the ancient Iranian mythology there is another type of cow that is named Ovagdat. This sort of animal carries the seed of the quadruped and even some useful plants. This species is similar to the Iranian mythical tree that carries the seed of all the plants<sup>2</sup>. Ovagdat or Evakdat means unique. In the primordial time this type of cow had been the only creature on earth. Similarly, Keyumars, the first human, was also made from the soil afterwards. Ovgadat is sickened by Satan (Ahriman) and dies. Upon the death of Ovagdat fifty five types of medicinal plants grow out of its corpse and different animals grow out of his semen. The myth associated with this animal later was incorporated into Mithraism. However the cow in Mithraism is an evil animal. Another type of cow, which protected the border between Iran and Turan, is also seen in the stories. This cow is also killed by Kavous (Yahaqi, 1996: 360). In the selections of Zadsparam a relation can be seen between cow and water. During the day Satan sees the unique cow, which is a white and bright animal shining as the moon, near the Amu River. He wants to harm the animal but since the cow is near the water the animal is protected by the power of water because according to the mythology water is the best protector of every sacred animal against Satan (Qarashi, 2001: 211). Here a threesome relationship can be observed: the interrelation between the moon, water, and cow (Amuzgar, 1997: 32).

In Iranian ancient mythology the moon is as valuable as the sun. In Zoroastrian culture the moon is worshiped three times a month. Even Bundahishn introduces the moon as the protector of the semen of the quadruped and animals. Iranians believed that the moon had a

carrousel that was pulled by a cow that was made of light, two golden horns, and ten silver feet (Yahaqi, 1996: 385).

So far we have realized that the three of them are holy. It is not only in ancient Iran that water is considered as a holy element, because many ancient cultures value and respect it. These three creatures are similar in that they all vitalize and enliven. In some stories the cow (which means existence and life) and the water (which is the origin of creation) are considered as the principals of life. The moon is also the generator of rain and the seed of the living.

The Shahnameh does not mention the unique cow that is created before (or at the same time as) Keyumars (the first earthly human). Even it does not introduce Keyumars as the first human being; rather, it considers him as the first king of the world. Hence, we will not continue this discussion. Now we are going to study the manifestation of the cow in Shanameh.

This animal is mostly seen in the story about Fereydoun. However, "some of the legendary heroes that are described in the Avesta and some newer holy Zoroastrian text books probably belong to the pre-Zoroastrian era. In the pre-Zoroastrian Persia people who spoke Indian and Persian (that related through their language) were still considered a single group of people. With the advancement of the Zoroastrianism prophet and spread of this religion in Iran some of the pre-Zoroastrian notions and traditions were incorporated into the Avesta and especially in the Yashts<sup>3</sup>. Zam Yasht (the nineteenth Yasht) gives a full description of the heroes. All of the heroes also appear in the Shanameh that was written more than two thousand years after the Avesta." (Curtis, 1997: 26, 27).

Fereydoun is one of the heroes whose battle with Zahhak has been widely reflected in Iranian myths and the Shahnameh. From now on we will talk about Fereydoun and the relation between this hero and cow.

## Fereydoun and His Family

### Aubteen (Abtin)

"The father Fereydoun (the sixth Pishdadi king) is often known as Aubteen. However, in Pahlavi textbooks such as Bundahishan, Asbuyan, and Asbyan the names Aspyan and Athfyan are used to refer to the family of Fereydoun. Based on all the available stories it can be concluded that the family name of the ancestors of Fereydoun had been Athfyan. This word is another form of the word Aubteen...In the Islamic textbooks (such as Tarikh al-Taban<sup>4</sup>, etc.) this name is written as Athfyan and in the Shahnameh (and other Persian textbooks) it is

<sup>1</sup> The author of "Some Problems of Early Iconography".

<sup>2</sup> According to ancient stories it is a tree named Harvisp that carries the seed of all the plants and hosts the nest of simurgh.

<sup>3</sup> A collection of twenty-one hymns in Younger Avestan.

<sup>4</sup> The History of the Prophets and Kings.

written as Aubteen. It seems that the latter word is another form of the word Autbeen.” (Yahaqi, 1996: 31) According to the author of “*The Rituals and Legends of Ancient Iran and China*”<sup>1</sup> the name of Fereydoun’s father was Aspin-Tora (Kouyaji, 1974: 181). In the Avesta it is written as Athwya (or Aspyan). Tora is a cow named Hozvaresh, whose Arabic name is Thor. Tora was the adjective that was attached to the name of Fereydoun’s father (Yahaqi, 1974: 31).

### Fereydoun and Iranian Stories

Pahlavi form of the name Fereydoun is Faritun. In Avestan language it is known as Thraetaona, which is derived from the word Threatch (meaning the third person). Fereydoun is called by this name maybe because he was the younger than his two brothers<sup>2</sup>. In the Shahnameh, his brothers are called Kianush and Birmaya (Kazzazi, 2000:294, 295). Based on another account this name was written as Trita-Aptya, which means the third child of water (Bahar, 2002: 474). Hence, this word is related to the named of his father (Aubteen), because the word Aubteen consists of two parts: Aub (meaning water) and teen.

According to another account “as far as the time and place value network is involved, in the late Stone Age (from the Bronze Age to the beginning of the Iron Age) proper nouns and names of places were introduced into Indo-European languages. These names were proportionate to the culture and vision of the societies of that time. Fereydoun is an Aryan mythical hero, who is named Thraetaona (meaning three times more powerful) in the Avesta. His main weapon was a trident using which he killed a three-headed dragon. One must feel himself completely in that situation in order to be able to conceive the purpose of the usage of this number (3) in all those names. (Qarashi, 2001: 8).

According to Jalaladdin Kazzazi, later on the word “Thar” (the first part of the name) was turned into the word “Far” in Pahlavi and Persian languages (Afterwards it formed the names Faritun and Fereydoun). Furthermore, Avestan adjectives that were used to describe him included Venisaputharo Athbyanoesh and Visororya Thraetaona which meant Athfyan dynasty and powerful dynasty of Fereydoun, respectively. Another Avestan adjective used to describe him was Janthe Azhnish Dahakay (the killer of Zahhak’s snake) (Kazzazi, 2000: 295).

According to Ali-Akbar Dehkhoda, Fereydoun is one of the greatest fictional figures of Iranian stories narrated

by Indian-Iranian tribes and also a Pishdadi king who was one of the offsprings of Tahmuras Diveband (Dehkhoda, 1998, vol 1: 17140).

Tabari and Biruni have mentioned the names of Fereydoun’s ancestor together with the word cow (Persian: گاو). In addition, based on Darmesteter’s account the reason for using the word cow was that Fereydoun’s family members were all farmers. In Bundahishn, Aspyan and Athfyan (i.e., Autbeen) is used to refer to the Fereydoun family, and Porgav (a person who owns many cows) is used to refer to his father (Safa, 1973: 465).

Not only were all of the Fereydoun’s ancestors named cow, but also he had a cow (either a cow or a bull) named Purmaya or Birmayoun who raised him. There is no trace of the existence of this cow in the Avestan and Pahlavi works. Moreover, there is also a relation between the name of this cow, the name of Fereydoun’s name in Pahlavi books (Porgav), and the name of his brother in the Shahnameh (Birmayeh).

According to the Shahnameh, Fereydoun was raised in a meadow and was nourished by Birmayoun<sup>3</sup>. In Bundahishn it is described as follows:

It is also said that Fereydoun’s splendor got stuck in the straws of Fraxkard Ocean and Dargah<sup>4</sup> went there and unleashed a cow on that land by the use of magic. He reaped straws for one year and fed the cow. Therefore the splendor was transferred to the cow. He milked the cow and fed his three sons (Vamoun, Shoun, Changrangha or Yand) and thus the splendor was transferred to Faranak (and not to the sons) (Sarkhosh, 2010: 123). Therefore, the royal splendor was transferred from the straws to the cow and from the cow to Faranak (the mother of Fereydoun). Hence, the splendor is not transferred to Fereydoun via his father because it was transferred to him via his mother (Sarkhosh, 2010: 124).

In the Shahnameh, Fereydoun says the following words about the cow:

My sire was fortune's favourite,  
But still Zahhak seized on him in Iran  
And slew him cruelly, so I have set  
My face against Zahhak's throne in revenge.  
He slew the cow Birmaya too - my nurse,  
A very gem of beauty. What could he,  
That villain, gain by slaughtering that dumb beast?  
Now I am ready and I purpose war. (Ferdowsi, vol 1, Zahhak, 323-325<sup>5</sup>)

“Based on the Iranian stories, Fereydoun is closely associated with health and medicine. His armor is

<sup>1</sup> A book written by Jahangir Kourji Kouyaji.

<sup>2</sup> He had two brothers, both of noble birth and older than himself, Hight Kaianush and prosperous Purmaya. (Ferdowsi/ Vol. 1/ Zahhak/ 255 and 256) (translated by Warner, Atkinson, and Zimmerman)

<sup>3</sup> See Ferdowsi, vol 1, Zahhak, 106-131.

<sup>4</sup> Faranak’s father according to ancient stories.

<sup>5</sup> Translated into English by Warner, Atkinson, and Zimmerman.

Bahrami and he owns a charm and divine splendor (Varj<sup>1</sup>) such that according to a legend in the fifth Yasht of the Avesta Fereydoun turned a lieutenant into a carcass, who was flying for three days. He is also praised for treating illnesses, nightmares, and hallucinations using Faravahar." (Rastgar Fasayi, 2000: 194, 195). "In Farvardin Yasht Fereydoun is able to cure some sorts of diseases and resist scabies, fever, and snake poison. Therefore, Fereydoun is praised as a warrior and healer." (Curtis, 1997: 29). According to Mehrdad Bahahr, his treatment method can tell about the primary structure of Indo-European tribes in which the chieftain is the magician and champion of the tribe as well. In the case of Fereydoun, he is a champion, king and a magician as well because when his children return from their honeymoon, he turns himself into a dragon by the use of magic (Bahar, 2002: 227 and 228).

Kouyaji draws similarities between Fereydoun and Zahhak and Marduk<sup>2</sup> and Tiamat<sup>3</sup>. He considers Marduk and Fereydoun as two bulls. On the other hand, Fereydoun, who wants to revenge the death of his nurse (Birmaya), can be considered as a bull or champion because he has an ox-headed mace and a bull as his brother (Birmayoun). His father is also known as a cow. His Derafsh Kaviani (i.e., royal standard) is also very similar to a cow. Marduk is also a capon castrated bull or even a bull god. In fact, Marduk and Assur (the Babylonian god) are the same. Assur had also a standard that displayed the image of the head of a bull with erected horns. In fact, the bull had been his standard. In addition, both of them defeat a dragon. Fereydoun kills the three-headed dragon and Marduk kills Tiamat (who captures the seas) (Kouyaji, 1974: 180, 181).

The author of "From another Species" believes that Fereydoun is related to the sun on one hand and to the water on the other hand. He argues that the first part of the word Aubteen is composed of the word Aub (meaning water), and thus considers it as a proof of his claim (Kazzazi, 1989: 54). Once again the relationship between water and cow is stressed. In fact, it can be said that dragon is the symbol of drought and famine against which the cow rises. The cow turns itself to the rain and protects the world against this evil power.

#### **Derafsh Kaviani**

<sup>1</sup> Dekhoda, 1998, vol 15, p 23156.

<sup>2</sup> Marduk was the greatest God (the God of the gods) of Babylonia in the ancient times and the killer of Tiamat (Ma'sumi, 2008: 73).

<sup>3</sup> Tiamat was an anarchist dragon and symbol of sea and saltwater. It was killed by Marduk. After its death the creatures are created out of his body members (Ma'sumi, 2008: 85 and 192).

The word Derafsh (meaning standard; Persian: درفش) is spelled the same in Pahlavi language. Another form of the word is Derakhsh which derives from Derakhshidan (shining; Persian: درخشیدن). Maybe the Derafsh Kaviani (Kaveh's flag) is named so because of the shining jewels, which were added to it by Fereydoun (Kazzazi, 2000: 355). Other forms of this word include Kabian, Kafian, Kavan, and Gavan Derafsh, Kaveh's flag, and Fereydoun's standard (Yahaqi, 1996: 192).

According to the literature, the Pahlavi equivalent of the word Derafsh is Alam (standard; Persian: علم) because whenever they opened the standard it would illuminate the world by its shining jewels. This standard was in Iran's treasury by the end of the Sassanid era (kingship of the last Yazdgerd), but in the Battle of al-Qadisiyyah it was captured by the Muslims. The Muslims took the standard to Umar ibn al-Khattab. Umar had the jewels removed from the standard and its cloth burned. The Hom Yasht, refers to a standard named "Gav Derafsh" (bull-like standard). Some researchers call it the Derafsh Kiavni, but the Gav Derafsh had been flag used by the Assyrian. Other researchers argue that the royal standard (Derafsh Kaviani) derives its name from the word Kouy or Kavian (meaning King), which is used as an adjective that is equivalent to the word royal. Hence, Derafsh Kaviani means royal standard or flag (Yahaqi, 1996: 192).

However, in the book titled "Iran History of Flag" the Derafsh Kaviani is introduced as a national standard which was different from the royal standard. If the king could not participate in a battle, he would send the royal standard (which represented victory and triumph) to the battle.

It was an honor to keep the standard. Hence, the military commander chosen for this task could also have the golden timpani, elephant, and shoes as the accessories required for accomplishing this task (Nayer Nouri, 1965: 18-20).

In some sections of the Shahnameh references are given to the royal standard. Based on the descriptions provided in the Shahnameh, the royal standard is not the same as the Derafsh Kaviani. For example:

There is a turquoise throne blue as the Nile,  
A flag charged with a yellow sun, the stall'  
Crowned with a golden moon, the case of purple.  
Who is the man thus stationed in the centre? "  
Hajfr replied: "The Shah, and at his gate  
Are elephants and lions." (Ferdowsi, vol 2, Sohrab, 547-549<sup>4</sup>).

These lines are in the form of a question-answer dialogue between Sohrab and Hajir. In this battle Kaveh's flag was hung to the doors of the stable and

<sup>4</sup> Translated into English by Warner, Atkinson, and Zimmerman.

Rustam's tent but Rustam's flag was in the form of a dragon:

As to yon green enclosure  
In front whereof are stationed many troops,  
While in the midst a splendid throne is set  
With Kawa's flag before it. On the throne  
A paladin is seated, one that hath  
The Grace, the neck, and shoulders of a hero,  
And seated thus is higher by a head  
Than any of the people standing near. (Ferdowsi, vol 2, Sohrab, 558-560<sup>1</sup>).

There is a dragon, look! upon his standard,  
And on the staff-top is a golden lion. (Ferdowsi, vol 2, Sohrab, 566<sup>2</sup>).

In other parts of the Shahnameh, where another commander is in charge of keeping the standard, the king has his own standard:

"Iranian soldiers prepared themselves for the war, except for Tus, the son of Nodar, who had a timpani and a golden shoe and carried the Derafsh Kaviani. (Ferdowsi, vol 3, Siavush, 3580 and 3581).

Therefore, this standard is not the same as the royal standard; rather, it is the national standard and the first standard that made by Kaveh by forging leather. Perhaps this nominal complication is caused by the shape of the word Kaveh (Persian: کاور), which is similar to the word King.

On the other hand, as it was mentioned earlier, the similarities between Fereydoun and Marduk (both of whom defeat a dragon), the fact that Marduk owns a cow-like flag, and the fact that the Derafsh Kaviani is named Gavan Derafsh<sup>3</sup> (flag of cows) in Dekhoda's Dictionary and Encyclopedia of Mythology and Fictional References, suggest that the Derafsh Kaviani had been also a cow-like flag that belonged to the Fereydoun family. Fereydoun used this flag and an ox-headed mace to fight Zahhak.

## Kaveh

<sup>1</sup> Translated into English by Warner, Atkinson, and Zimmerman.

<sup>2</sup> Translated into English by Warner, Atkinson, and Zimmerman.

<sup>3</sup> See Dekhoda, 1998, vol 7, p. 10633; and Yahaqi, 1996, p. 192.

According to Moein Encyclopedia, Kaveh is the name of one of the famous mythical athletic families of Iran. Moreover, the name of some of the figures of this family (such as Kaveh, and his two sons Karen and Kobad) is mentioned in the Shahnameh (Moein, 1996: 1542).

The Pahlavi equivalent of Kaveh is Kavag, which is definitely related to the words Kouy and Kay (king) (Kazzazi, 2000: 302). In some Islamic textbooks (such as the translation of Tarikh al-Taban) this word is written as Kabi (Yahaqi, 1996: 346).

"The story of Kaveh is not mentioned in the Avesta. Even in works written in Pahlavi no trace of this story can be found. However, the existence of a story about Kaveh in the Sassanid era cannot be denied. Arthur Christensen wrote a treatise in Danish. In his work, he tries to demonstrate that the Avesta and Zoroastrian religious books do not include a myth about Kaveh and thus the myth of this mythological character belongs to the Sassanid era. The story of Kaveh is an imitation of another ancient myth which helps to define the Derafsh Kaviani (meaning Kaveh's flag). However, Derafsh Kaviani is actually defined as the Royal Standard." (Dekhoda, 1998, vol 12: 18122)

Hence, assuming that both Kaveh and Derafsh Kaviani belong to the Sassanid era, the Derafsh Kaviani can be considered as the royal standard of that time. Nevertheless, this point cannot be discussed in this paper. Based on some evidence it seems, however, that the king's standard and the royal standard had other usages and that there was a difference between these flags and Kaviani's flag. This flag is manifested differently in the Shahnameh. In other words, it belongs to the family of Fereydoun, whose symbol is cow. In addition, Kouyaji associates cow-like flag with Assur<sup>4</sup>. He also draws other similarities between Marduk and Fereydoun. The Kaviani flag mentioned in the Shahnameh (especially in the story about Fereydoun) is the symbol of Fereydoun and his revolt against the three-headed dragon (Zahhak).

On the other hand, Fereydoun had an ox-headed mace<sup>5</sup> made before rising against Zahhak because he wanted to crush Zahhak's head with it. This mace is also the symbol and representative of cow. Of course, this mace did not only belong to Fereydoun because other dragon killers (such as Garshab) had also such a mace. Therefore it can be concluded that cow and dragon has been in a long-time war that may date back to the pre-historic era and the days of creation.

## Fereydoun and the Shahnameh

<sup>4</sup> Assur is a Babylonian god whose counterpart is Marduk.

<sup>5</sup> He drew an image on the earth that was similar to the head of a bull.

The story of Fereydoun in the Shahnameh begins when one night Zakhak dreams of three warriors after a thousand years of tyranny. One of the warriors (the third and the youngest one) approaches him with an ox-headed mace and puts a leashes him and takes him to Mount Damavand. After his dream is interpreted Zakhak realizes that a person named Fereydoun will be born who will overthrow him. Finally:

Years passed away, calamity approached  
The dragon-king, the blessed Faridun  
Was born, the fashion of the world was changed.  
Of cypress height he shone forth with the Grace  
Of kings of kings which crst Jamshid possessed,  
Was like the sun, as needful as the rain  
To earth and fit as knowledge to the mind  
Revolving heaven loved him tenderly.  
Then lived the cow Birmaya, chief of kine,  
Born with a coat all bright and peacock-hued.  
The wise, the archmages, and astrologers  
Collected round her; none had seen or heard  
Of such a cow before. (Ferdowsi, vol 1, Zakhak, 106-113<sup>1</sup>)

As the Shahnameh suggests Fereydoun and the cow are the same. The cow is unique and beautiful like a colorful peak-cock.

Meanwhile Fereydoun's father is captured by Zakhak's courtiers and his brain is given as a food to his snakes. Fereydoun's mother, Faranak, takes her child to the meadow where Birmaya lives. The guardian of the cow and the meadow accepts Fereydoun and feeds him for three years with the milk of the cow<sup>2</sup>.

The cow becomes famous and thus upon revelation Faranak takes Fereydoun from the meadow to the border of India, where Mount Alburz stand. He gives Fereydoun to a religious man living in that mountain. Zakhak kills Birmaya, and according to the myths and narratives, Fereydoun swears to Birmaya's blood to kill Zakhak.

He came and slew the noble, tender nurse  
That could not speak to thee. (Ferdowsi, vol 1, Zakhak, 170<sup>3</sup>)

This cow is Fereydoun's nurse and maybe murder of this cow is the reason for Zakhak's gloomy fate. Zakhak prepares a testimony in order to exonerate himself. He orders everybody to testify that he is innocent. At this point Kaveh the blacksmith rises and asks Zakhak to free his youngest son, who is captured by Zakhak's guards. Zakhak inevitably frees his son. However, Kaveh refuses to testify that Zakhak is innocent, tears the testimony, and leaves the court. He summons the people and puts the leather that he used to put around his

foot on a spear and goes to Fereydoun. Fereydoun also adds a star to the leather, decorates it with silk, and calls it the Derafsh Kaviani. Then, he creates his famous ox-headed mace<sup>4</sup> and goes to fight Zakhak<sup>5</sup>.

Murder of a dragon by a hero is a frequent theme and motif that is seen in many cultures. Iranian culture does also include many examples of this motif. This mythical manifestation form also been repeatedly manifested in the Shahnameh. The heavenly hero always defeats the dragon in a hard battle. This can be considered as the symbol of the victory of divine forces over evil forces.

"Murder of dragons in mythology is a religious and ritual act, which is generally associated with cosmologic events and beliefs about creation and recreation of the world. According to this type of mythology a triumphant God that has a sun-like or fire-like face fights an evil demon (who captures the seas) with a snake- or dragon-like body and defeats it. Therefore, the seas are freed and the evil spirits and heavenly spirits live in peace. (Yahaqi, 1996:189).

The following lines from the Shahnameh can partly demonstrate the point:

With head raised o'er the sun he girt his loins  
For vengeance for his father, and set forth  
Upon the day Khurdad right joyfully  
With favouring stars and splendid auguries. (Ferdowsi, vol 1, Zakhak, 269, 270<sup>6</sup>)

And:

Now Faridun, when twice eight years had passed,  
Sought out his mother on the plain and said:  
"Disclose thy secret, say who is my father,  
What is my lineage, whom shall I declare  
Myself in public? Let me have the truth." (Ferdowsi, vol 1, Zakhak, 149-151<sup>7</sup>)

It also mentions Mount Alburz in the following lines:

The realm is mine, your fortune's star  
Is bright, for me alone did God send forth  
From Mount Alburz by Grace, and for your sakes,  
To set the world free from the Dragon's bane. (Ferdowsi, vol 1, Zakhak, 449-450<sup>8</sup>)

Regardless of the above lines Fereydoun is sometimes introduced as a fire worshiper (Yahaqi, 1996: 331).

<sup>1</sup> Translated by Warner, Atkinson, and Zimmerman.

<sup>2</sup> See Ferdowsi, vol 1, Zakhak, 106-131.

<sup>3</sup> Translated by Warner, Atkinson, and Zimmerman.

<sup>4</sup> They took the work in hand, and having wrought. (Ferdowsi, vol 1, Zakhak, 263 and 264).

<sup>5</sup> See Ferdowsi, vol 1, Zakhak, 183-245.

<sup>6</sup> Translated by Warner, Atkinson, and Zimmerman.

<sup>7</sup> Translated by Warner, Atkinson, and Zimmerman.

<sup>8</sup> Translated by Warner, Atkinson, and Zimmerman.

However, the above lines refer to Fereydoun's uprising on the day Khurdad. The day Khurdad was the sixth day of the month. This day was also in charge of nursing the waters (Yahaqi, 1996:104). We discussed the relation between cow and water earlier. It was also mentioned that the moon, water, and cow are interrelated, while cow is does belong to the moon. Later, the sun overcomes the moon and the essential characteristics of the moon are transferred to the sun.

Maybe this is when Fereydoun overcomes the sun. On the other hand, since he was 16 years old he climbs down Mount Alburz and asks his mother about his background. Perhaps this reflects another relationship between day Khurdad and the sun, because the sixteenth day of each month is named the day of Mitra/Mehr or the Sun. Moreover, according to the mythology the sun lives behind the Mount Alburz, and Fereydoun also climbs down this mount and revolts against Zahhak.

In short, based on the contents of the Shahnameh, the dragon-killer Fereydoun who is associated with cow is related to either the sun or the moon.

## Conclusion

One of the principals of totemic religions is that the people and tribes name themselves after the name of their totemic animal. As it was shown, the nicknames of all the ancestors of Fereydoun were names combined with the word cow. In addition, based on the contents of the Shahnameh and the available stories, cow was Fereydoun's nurse. This is associated with one of the principals of totemism according to which the totem (Fereydoun's nurse in this case) protects and supports its tribesmen. On the other hand, since this cow is murdered by Zahhak Fereydoun (that has the sign of cow) revolts against Zahhak (that has the sign of dargon). This is because killing a totem is taboo and Zahhak is punished for killinh the totem.

Another principal of totemism was that tribes use the images of animals as pictures representative of themselves. Fereydoun also had an ox-headed mace made to use it in his fight against Zahhak. In this war, the mace of Fereydoun is the symbol of the Athfyan family.

As it was mentioned, splendor is transferred to Fereydoun via his mother (Faranak). This is also suggestive of another important principal of totemism.

On the other hand, according to some of the scholars there are similarities between Fereydoun and Marduk (the Assyrian god who defeats the Tiamat). Marduk, like Fereydoun, was associated with cow because he also uses a standard charged with a cow in his battle against the dragon-like Tiamat. Therefore, Fereydoun's Kaviani Derafsh is also charged with the image of a cow. He also uses this standard to defeat a dragon (Zahhak).

Another recurring motif in these stories is their reference to number three: Fereydoun is the third son of the Athfyan family; he also has three son; and he has trident (a three-headed mace. Number three is also

associated with the moon because moon has three phases: first it is in the form of crescent, then we have the full moon, and at the end of the month it disappears. All this narratives are representative of a religion which values cow. It even suggests that the Athfyan family and Fereydoun were worshiper of the cow.

Cow was somehow the totem and symbol of Fereydoun and his family. In the Shahnameh, ge uses it in various ways in his fights against the dragons.

## Bibliography

1. Azadegan, Jamshid. 1993. *Primitive Religions: A Study of Totemism*. First edition, Mirath Melal Publications.
2. Amuzgar, Zhaleh. 1997. *Iran Mythical History*. Second edition. SAMT Publications.
3. Bahar, Mehrdad. 2002. *A Study of Iranian Mythology*. Fourth edition. Tehran. Agah Publications.
4. Palmer, Michael. 2006. *Freud, Jung, and Religion*. Translated by Muhammaf Dehganpour and Qolamreza Mahmudi. Tehran. Roshd.
5. Dehkhoda, Ali-Akbar. 1998. *Dehkhoda's Dictionary*. Assembled under the supervision of Muhammad Moein and Seyyed Jafar Shahidi. Volume 7,11,12,15. Second edition. Tehran, Dehkhoda's Dictionary Institute.
6. Rastergar Fasayi, Masnour. 2000. *Dragon in Iranian Mythology*. First edition. Tehran. Tus Publications.
7. Sarkhosh, Faeqeh. 2010. *The Myth of Earth and Heaven: Earth and Heaven in Iranian Thought*. First edition. Tehran. Tarfand.
8. Challaye, Felicien. 1976. *A Brief History of Great Religions*. Translated by Manuchehr Khodayar Muhebbi. Second edition. Tehran. Tahuri Library.
9. Safa, Zabiullah. 1973. *Epic Storytelling in Iran (from the oldest times to the fourteenth century)*. Third edition. Tehran. Amir Kabir Publications.
10. Samadi, Mehrangiz. 1988. *Moon and Iran (from the oldest times to the emergence of Islam)*. First edition. Scientific and Cultural Publications Company.
11. Ferdowsi Tusi, Abolqasem. *The Shahnameh*. Passages were extracted from the Moscow edition by Saeed Hamidian. Fifth edition. Tehran. Qatreh Publications.
12. Freud, Sigmund. 1976. *Totem and Taboo*. Translated by Muhammad Ali Khanji. Second edition. Tehran. Tahuri Library.
13. Qadiani, Abbas. 1995. *The History of Religions in Iran*. First edition. Tehran. Anis Publications.
14. Qarashi, Amanallah. 2001. *Water and Mountain in Indian-Iranian Myths*. Tehran. Hermes Publications.
15. Curtis, Vesta Sarkhosh. 1997. *Iranian Myths*. Translated by Abbas Mokhber. Second edition. Tehran. Markaz Publications.

16. Kazzazi, Jallaladin. 2000. *A Letter from the Ancient Times (revision of Shahname Ferdowsi and a report on it)*. Volume one. Tehran. SAMT Publications.
17. Kazzazi, Jallaladin. 1989. *From another Species (a study of Iranian culture)*. First edition. Tehran. Franklin Publications.
18. Ma'sumi, Qolamreza. 2008. *An Introduction to Ancient Myths and Religions of the World*. Second edition. Tehran. Surah Mehr Publication Company.
19. Moein, Muhammad. 1996. *Persian Culture*. Ninth edition. Tehran. Amir Kabir Publications.
20. Nayyer Nouri, Hamid. 1965. *The History of Iran's Flag and the Lion and Sun Sign*. Published by the Institute of Social Studies.
21. Yahaqi, Muhammad Jaffar. 1996. *Encyclopedia of Myths and Fictional References in Persian Literature*. Second edition. Tehran. Soroush Publications.

11/6/2012

## The Comparison of Stressors in the Assessment of Basic Clinical Skills with Traditional Method and OSCE in nursing Students

Maryam Bagheri<sup>1</sup>, Malihe Sadeghnezhad Forotgheh<sup>2</sup>, Maryam Shaghayee Fallah<sup>3</sup>

<sup>1</sup>Department of medical-surgical nursing, school of nursing and midwifery, Mashhad University of Medical Sciences, Mashhad, Iran

<sup>2</sup>Department of nursing, Islamic Azad University of Medical Sciences, Mashhad, Iran

<sup>3</sup>Department of Operating room & Anesthesia Nursing, school of nursing and midwifery, Mashhad University of Medical Sciences, Mashhad, Iran

[shaghaem@mums.ac.ir](mailto:shaghaem@mums.ac.ir)

**Abstract:** Evaluation of clinical competency of nursing students in the achieved skills and judgment in this case, is one of the important matters of clinical education. Using the right method of evaluation plays a considerable role in getting the appropriate result and making the right judgment. The purpose of the present study is comparing stressors in basic clinical skills Evaluation with traditional and OSCE methods in nursing students. This is A comparative description study. Sampling was done through census. 25 students of the second term nursing whose practical course of fundamental of Nursing and skills evaluation had been done by traditional method and they had passed last term, were assessed at the end of second term through OSCE test. After taking the OSCE, the students filled the researcher made questionnaire with the purpose of examining their opinions, about stressors in both methods. The comparison of the result of the survey shows that the rate of stress while doing the techniques, stress of time limitation, confusion during the test, complication of the test method and encouraging students to active participation in learning in OSCE method was meaningfully more than the traditional method and the traditional evaluation was not considered as an encouraging method for active learning and fair and accurate evaluation of clinical skills of students. OSCE is recommended as one of the most appropriate methods in evaluation students' clinical skills because of assessing students fairly and equally and encouraging them to active learning although there was stress before and at the moment of doing the techniques. Also the program of familiarizing students with this method of evaluation during the term and some corrections in its performance seem necessary.

[Bagheri M, Sadeghnezhad Forotgheh M, Shaghayee Fallah M. **The Comparison of Stressors in the Assessment of Basic Clinical Skills with Traditional Method and OSCE in nursing Students.** *Life Sci J* 2012;9(4):1748-1752] (ISSN:1097-8135). <http://www.lifesciencesite.com>. 266

**Keywords:** Clinical evaluation; OSCE; Stress; Nursing Students

### 1. Introduction

Clinical education is one of the important and basic principles in nursing education which is accepted by all programmers and managers of educational programs of this field as the main part of nursing education. During this process the student achieves clinical experiences beside the patient while facing problems in the hospital (Moatari et al. 2007, Chehrzad et al. 2004).

Because of these assessing students' clinical competency of the achieved skills is one of the most difficult tasks of faculty members and health program educator (Noohi et al. 2008, Walsh 2009). According to the fact that evaluation is judgment process about the effectiveness of the individual's educational experiences through appropriate measurement, the method of doing it could improve the quality of teaching, learning, and training (Chehrzad et al. 2004). The results of studies show that evaluation methods in most clinical courses, besides not matching the educational goals are not effective enough in assessing clinical skills and performances

of students and although clinical skills and practice play the main roles in training different groups of medicine, the success of trainees of these fields depends on what they memorize to some extent (Noohi et al. 2008, Casey et al. 2009). During the past 40 years gradual evolution in different methods of clinical evaluation and the appearance of structured objective clinical evaluation as a method of assessing clinical competency in medical education is one of them. At present, this method has attracted considerable attention because of high level of reliability, credit and objectivity, content validity of the achieved skills, fairness, creating motivation for learning, and instructors' and students' satisfaction (Chehrzad et al. 2004, Rushforth 2007, Walsh 2009, Furlong et al. 2005, Selim et al. 2012). Different studies have confirmed that OSCE is a fair and objective method in assessing clinical skills (Nicol & Freeth 1998, Huang et al. 2007). According to this fact that the course of nursing skills and principles is one of the basic courses in clinical education of nursing students and learning techniques



before starting clinical training are of prime importance and students' satisfaction rate with the evaluation method can be effective in creating motivation in their learning, the present study was conducted and planned with the purpose of comparing stressors in two methods of clinical skills evaluation (traditional and OSCE) on second term nursing students of Mashhad Nursing and Midwifery School.

## 2. Material and Methods

This study was a comparative description which was conducted in Nursing and Midwifery School of Mashhad. Sampling was done through census. 25 students of the second term of nursing whose assessment of practical course of fundamental of nursing skills was done through traditional method in the first term and had passed the test, were assessed in the second term for the end-course evaluation of the practical course of Nursing Skills and Principles through OSCE method. The method of conducting the traditional method in the first term was as follows; students chose one of the trained techniques in the first term through random and performed it while the instructor observed. It is worth mentioning that as all the techniques were not equally complex, the time of performing it changed according to previous background of the student in the instructor's mind, the complexity of the technique, and etc. OSCE was performed as the assessment method of the trained skills in the second term which was as follows; first after determining the number and kind of station based on the trained techniques and available facilities (four ten-minute station of wound dressing, venous injection, Bladder catheterization and preparing medications), the examiner's and student's instructions and also the checklist of each station were provided. Then settings of the station were planned. All the students did the techniques equally and at the same time and were assessed by the observer on the basis of the checklist. After the conduction of the exam, the researcher-made questionnaire was filled by the students for studying and comparing the stressors. This questionnaire was studied by some nursing professors and its content validity was confirmed, and its reliability was also confirmed through test-retest method ( $r=0.75$ ).

## 3. Results

Out of 25 participants 92% ( $n=23$ ) were females and the rest were males. The average age of the students was 21 and most of the participants (72%) lived in Mashhad. The results of analysis the questionnaires of comparing the stressors in the two methods of traditional and OSCE were as follows; in

OSCE students were more stressed than the traditional method. Also in OSCE because of more number of stations than the traditional methods students were more stressed. Most of the students considered time limitation as one of the important factors in producing stress in OSCE method. But at the same time they mentioned that OSCE method provides equal conditions for assessing all the students while in traditional method, as the tested technique is chosen through random, chance is also involved, and according to the differences in the complexity and necessary efficiency for performing each technique the students expressed that this method does not provide equal conditions for assessing all the students. Most of the students considered OSCE more accurate than traditional method for assessing learning and skills of the students but expressed that it is more complicated than the traditional method. Encouraging students to active participation in learning is another advantage of OSCE, which was mentioned by most of the students. The comparison of the results of surveyed shows that the rate of stress while performing the techniques, stress originated from time limitation, confusion while taking the exam, complexity of the method of the exam, and encouraging the students to active participation in learning in OSCE method were significantly more than the traditional method (table 1). Although there is more stress in different aspects of OSCE, it seems that students are more satisfied with their achieved score in the traditional method. Also in another part of the questionnaire students' opinions about different specifications and station of OSCE were examined.

## 4. Discussions

Conducting an accurate and fair method of assessment which is appropriate with the expected clinical skills has always been concerned since the past (Nicol & Freeth 1998).

This study showed that totally the advantages and disadvantages of OSCE compared with the traditional method of assessing nursing students' clinical skills in students' opinion are as follows; OSCE is a more accurate, fairer, and more effective method in creating learning motivation for students but it is more complex and stressful than the traditional method. Time limitation is another negative specification of OSCE which causes a lot of stress among students.

Many et al (2007) studied medical students' satisfaction with OSCE method. The cases they studied included satisfaction rate with the content, atmosphere, performance method, environment, the effect of exam method on improving clinical skills, instructors' feedback at the time of exam, and total

**Table 1: The Comparison of view point of students about effects two clinical evaluation methods**

Frequency	Osce			Traditional			t	sig
	High	Low	None	High	Low	None		
Calmness before exam	44	28	28	12	56	32	-1.142	0.226
Stress while performing the techniques	72	28	0	16	60	24	-4.101	0.001
Stress for exam	64	32	4	40	44	16	-1.239	0.228
Stress from time limitation	72	24	4	12	32	56	-5.477	0.000
Confusion while taking the exam	56	36	8	16	28	56	-2.524	0.02
Accurate measurement of learning& skill	52	32	16	16	48	36	-1.865	0.076
Easy performing the techniques	44	36	20	28	36	36	-0.839	0.411
complexity of the method of the exam	32	44	24	32	32	36	-0.176	0.862
encouraging the students to active participation in learning	52	28	20	12	44	44	-2.160	0.042
Satisfaction of number of exam	52	44	4	20	52	28	-2.017	0.047

satisfaction of students with OSCE. The result of the survey showed that the majority of students were satisfied and expressed that its effect on improving clinical skills was pleasing (Huang et al. 2007).

In the present study most of the students expressed that OSCE, although being complex is an appropriate method of assessing clinical skills. The results of Abir et al.'s study (2012) with the purpose of studying the validity and reliability of OSCE in assessing nursing students' skills showed that students considered OSCE as a very positive experience but at the same time stressful. Also in this study it has been mentioned that OSCE is a valid and reliable method for examining clinical skills of nursing students and is more accurate than the traditional method which matches the results of the present study (Casey et al. 2009). Smith et al. (2012) compared different methods of assessing midwifery students' clinical skills, the results expressed that none of the assessment methods of clinical skills can provide complete information about the students' skills but OSCE method can be used as a very valuable method for assessing clinical competency of medical science students because of appropriate reliability in comparison to methods such as worksheet, clinical observance, and etc.(Smith et al. 2012). This result confirms credit and high accuracy of OSCE in assessing clinical skills of students which is confirmed by the current study as well.

In Marion et al.'s study (2009) as been mentioned that in contrast with various positive specifications of OSCE, for better usage of this method in assessing clinical skills of nursing students, it is essential that this method is used besides other

methods of assessment so that more accurate and favorable results will be found for judgment (Mitchell et al. 2009).

In Braznan et al.'s study ((2006), the effect of using OSCE on the self-confidence of nursing students and their point of view toward clinical practice was studied. The results showed that the students who got higher scores in OSCE assessment method had more self-confidence for doing clinical practice. But most of the students considered OSCE a stressful method for assessment. Specially students pointed the stress before the exam. Also they mentioned it was a meaningful and fairer method among methods of assessing clinical skills ( Brosnan et al. 2006).

In the present study, students mentioned that they were more stressed before the exam in this method than the traditional method. It seems that unfamiliarity of students with OSCE has caused this stress which may be decreased by the repetition of using this method.

Also assessment through OSCE because of objectivity and practical application of the necessary techniques increases the self-confidence in using the techniques while doing clinical work of course .Although OSCE method is the most accurate and valuable method in assessing the clinical skills of medical sciences student but it should be remembered that this method is very expensive and this is one of the disadvantages of OSCE in some institutes which is an obstacle for its application (Palese et al. 2012).

Nolti et al (2011) studied 58 nursing students' opinions that were assessed by OSCE. The researchers had wanted the students to express the

best and worst characteristics of this exam. The results were as follows: the best specifications included the student being aware of the examiner's exact expectations, the student has the chance to express all aspects of his ability in performing a technique, and the student feels that everything is provided for him to express his knowledge. The worst parts included: stress and anxiety of the student before the exam. Other negative experiences mentioned by the students were not being able to control their feelings while taken the exam and express their knowledge, time limitation of the exam, and the type of behavior of the examiner, these were considered as the most important stressors (Nulty et al. 2011).

In the current study, time limitation and being stressed before the exam were the cases expressed as negative specifications by most of the students.

One of the other positive specifications of OSCE is its positive effect on medical sciences students' learning, in a way that John et al's study in 2002 have shown that the students who are assessed by OSCE besides being in a more favorable status clinical competency are more skilled in examining the needs of patients. In fact OSCE is one of the factors which can decrease the distance between theory and practice which is one of the oldest problems in medical sciences education (Walters & Adams 2002).

Of other effects of OSCE, the positive effect on communication skills of nursing students which is of prime importance for identifying and managing patients' needs can be mentioned. The results of Martin and Theodor's study in 2002 expressed that using OSCE can improve interpersonal relationships of nursing students (Anderson & Stickley 2002). This result matches the represent study's result which is OSCE causes more favorable social relationships with classmates.

## 5. Conclusion

According to the results of the present study and reviewing the related studied, it can be said that with better planning in performing OSCE and familiarizing the students with the conditions and limitations of OSCE through practice during the term, stressors could be decreased logically. OSCE can be used as an appropriate method in evaluation basic nursing clinical skills because of various positive specifications such as; accuracy and fairness, encouraging students to active learning and increasing clinical competency and self-confidence of students for clinical practice. Therefore for improving the quality of holding this exam in faculties, people in charge had better care more about holding, providing space and enough facilities.

## Acknowledgements:

Finally the authors would like to express their gratitude to the director of the department and members of skill lab and students for all their support.

## Corresponding Author:

Maryam Shaghaee Fallah  
Department of nursing  
School of nursing and midwifery  
Mashhad University of Medical Sciences, Mashhad, Iran  
Email: shaghaeem@mums.ac.ir

## References

1. allahdadian M, Salehi Sh, Hasanzahraie H, Farahmand H. Proposing Appropriate National Standards for Nursing and Midwifery Education Derived from International Standards: a Case Study, Master of Science in Nursing and Midwifery. Iranian Journal of Medical Education 2008; vol:8; no :1; 15-20[In Persian]
2. Anderson M, Stickley T. Finding reality: the use of objective structured clinical examination (OSCE) in the assessment of mental health nursing student's interpersonal skills. Nurse Education in Practice 2002; 2: 160-168
3. Brosnan M, Evans W, Brosnan E, Brown G. Implementing objective structured clinical skills evaluation (OSCE) in nurse registration programmes in a centre in Ireland: An utilization focused evaluation. Nurse Education Today 2006; 26(2): 115-22
4. Casey PM, Goepfert AR, Espey EL, Hammoud MM, Kaczmarczyk JM, Katz NT, Neutens JJ, Nuthalapaty FS, Peskin EPetra M, etal. To the point: reviews in medical education — the Objective Structured Clinical Examination. American Journal Obstetric Gynecology. 2009; 200(1): 25-34
5. Chehrzad MM, Shafie Pour SZ, Mirzaei M, Kazem Nejad E. Comparison between two methods: Objective structured clinical evaluation (OSCE) and traditional on nursing students' satisfaction. Journal of Medical Faculty Guilan University of Medical Sciences. Summer 2004; 13(50):8-13 [in Persian]
6. Furlong E, Fox P, Lavin M, Collins R. Oncology nursing students' views of a modified OSCE. European Journal of Oncology Nursing (2005) 9, 351-359
7. Huang YS, Liu M, Huang CH, Liu KM. Implementation of an OSCE at Kaohsiung Medical University. Kaohsiung J Med Sci. 2007 Apr; 23(4):161-9
8. Mitchell M L,. Henderson A, Groves M, Dalton M, Nulty D. The objective structured clinical

- examination (OSCE): Optimizing its value in the undergraduate nursing curriculum. *Nurse Education Today* 2009;29(4): 398-404
9. Moatari M, Abdelah Zargar SH, Mousavinasab M, Zare N, Beygi Marvdasht P. Reliability and validity of osce in evaluation clinical skills of nursing students. *Pajouhesh Dar Pezeshki*. Spring 2007; 31(1):55-59[In Persian]
  10. Motamed N, Kashani Z, Safar MJ, Alian SH, Khademloo M, Eslamiyan R. Prescription writing ability of interns for common illnesses. *Journal of Mazandaran University of Medical Sciences-Sari Medical School* 2004. 16(51):101-110[in Persian]
  11. Nicol M, Freeth D. Assessment of clinical skills: a new approach to an old problem. *Nurse Education Today* 1998; 18(8): 601-609
  11. Noohi E, Motesadi M, Haghdoost A. Clinical Teachers' Viewpoints towards Objective Structured Clinical Examination. *Iranian Journal of Medical Education* 2008;vol:8; no :1; 15-20[In Persian]
  12. Nulty D, Mitchell M.L, Leffrey C.A, and Henderson A, Groves M. Best Practice Guidelines for use of OSCEs: Maximising value for student learning. *Nurse Education Today* 2011; 31:145-151
  13. Palese A, Bulfone G, Venturato E, Urli N, Bulfone T, Zanini A, Fabris S, Tomietto M, Comisso I, Tosolini C, Zuliani S, Dante A. The cost of the objective structured clinical examination on an Italian nursing bachelor's degree course. *Nurse Education Today* 2012; 32(4): 422-426
  14. Rasoulia M. Taghva A. Panaghi' L. Zahiroddin A. Salehi M. Ghalebani M. Qualitative Assessment of the First Objective Structured Clinical Examination (OSCE) in Psychiatry in Iran. *Journal of Psychiatry and Clinical Psychology*.2007;13(1):12-16[in persian]
  15. Rushforth H E. Objective Structured Clinical Examination: Review Of Literature And Implication For Nursing Education. *Nurse education today* 2007; 27:481-490
  16. Selim A, Ramadan F, El-Gueneidy M, Gaafer M. Using Objective Structured Clinical Examination (OSCE) in undergraduate psychiatric nursing education: Is it reliable and valid?. *Nurse Education Today* 32 (2012) 283–288
  17. Smith V, Muldoon K, Biesty L. The Objective Structured Clinical Examination (OSCE) as a strategy for assessing clinical competence in midwifery education in Ireland: A critical review. *Nurse Education in Practice* 2012; 12(5): 242-247
  18. Walsh m, bailey hill P, koren I. Objective Structure Evaluation of Clinical Competence: An Integrative Review. *Journal of advanced nursing* 2009; 65(8):1584-1595
  19. Walters J, Adams J. A child health nursing objective structured clinical examination (OSCE). *Nurse Education in Practice* 2002; 2: 224–229

10/5/2012

**Anthropometric assessment in children under 2 year in Torosk, a rural area of Sabzevar, Iran 2004-6**Akaberi Arash<sup>1</sup>, Hashemian Masoumeh<sup>2</sup>, Assarroudi Abdolghader<sup>2</sup>, Hasanpour Kazem<sup>2\*</sup><sup>1-</sup> Faculty member of Biostatistics, North Khorasan University of Medical Sciences, Bojnurd, Iran<sup>2-</sup> Faculty members, Sabzevar University of Medical Sciences, Sabzevar, Iran\* **Corresponding Author;** Sabzevar University of Medical Sciences, Sabzevar, Iran, Telfax: +985714446070

Email: drhasanpour@yahoo.com

**Abstract: Introduction:** Growth and development is one of the most complicated and significant issues in man's life. Growth monitoring is one of the main sources of information in diagnosing growth disorder and malnutrition in children. The present study was made to study the status of anthropometric indices in under two-year children in Torosk village, Sabzevar, Iran. **Method:** This cross-sectional study was done in 2007. The data of height, weight and head circumference of the children less than 24 months in 2004, 2005 and 2006 were collected through health files. The economic and social status of the families of these children was also evaluated. The statuses of growth of these children were compared with third, fifth and nine-seventh growth standard NCHS percentile. Growth percentile was calculated with SPSS 15 software and the diagrams were drawn by Excel software. **Results:** 135 children were studied in this research, (47.4% girls and 52.6% boys). Most parents were in low levels of education and none had academic education. The economic status of the studied families was low. 19.2% of newborn and 53.3% infants were below the third weight for age curve. 7.7% of newborn and 13.3% of infants were below third percentile of height standard. But head circumference did not exceed 8% in nobody. As the age of these children increased, the weight and height percentiles went farther from their corresponding standard percentiles. This was more evident beyond 12 months of age. **Conclusion:** The status of weight and height of under- two year children compared with NCHS standard is inappropriate and gets worse in 12 months of age and after that.

[Akaberi Arash, Hashemian Masoumeh, Assarroudi Abdolghader, Hasanpour Kazem. **Anthropometric assessment in children under 2 year in Torosk, a rural area of Sabzevar, Iran 2004-6.** *Life Sci J* 2012;9(4):1753-1758] (ISSN:1097-8135). <http://www.lifesciencesite.com>. 267

**Keywords:** Children, Growth Pattern, Anthropometrics

**Introduction**

Growth and development is among the most complicated and significant issues of the man's life. These two separate and at the same time related issues are the indicators of a living being's progress in both quality and quantity aspects (1). Growth assessment is one of the most important information sources in diagnosing growth disorder and malnutrition in children (2). Generally by the word growth, we mean quantity changes that cause increase in size in all dimensions of the infant. These changes are usually measured by centimeter and inch (for height) kilogram or pounds (for weight) (3).

General speaking, growth and development are influenced by two genetic and environmental factors. Genetic factors like ethnic specifications are fixed but environmental factors like nutrition, diseases infection and toxication can be controlled (4). Several studies on human biology have indicated that environmental factors specially the quantity and quality conditions of nutrition have the most influence on physical growth (4). Therefore the role of nutrition is the most significant among the environmental factors. Malnutrition accompanied with infectious diseases is the cause of death of seven million kids under 5 years old in developing countries every

year(4). On time diagnosis of growth disorder followed by on time prevention and treatment will be effective.

Failure to thrive or FTT refers to the growth below expected based on weight, height and head circumference(5). In another definition, FTT refers to the weight lower than the third percentile on growth standard curve or weight lower than 80% of average weight to height(5, 6). Children growth disorder is one of nutritional health issues in Iran. It is a multidimensional problem caused by organic and non-organic or both(7). National Center of Health Statistics (NCHS) announced that 226 million children in the world do not enjoy a favored growth. It is also estimated that about 67 million children have a low weight/height ratio and the weight of about 183 million children is not suitable for their age and the risk of death in low weight children is 2 to 8 times more than the children who have a normal weight for their age (8). The national studies made in recent years show that FTT in urban and rural children under 5 years old is still high. 15.4% of the children under 5 years old suffer from nutritional shortness (nutritional short stature), 10.9% are in moderate and severe low weight and 4.9% are thin(7). The results of a study published under title the status of children nutrition in

the country shows that the children in Iran have a favorable growth from the time of birth up to their five months .however 80% of them face drop in growth after that(7).

The most common method of measuring children' growth is measuring anthropometric indices(9). Today in most parts of the world assessing physical growth and health is done through simple indices like height and weight(10).

The main source of evaluating growth is growth curves; the majority of them are taken from indices of modern countries like United States (For instance NCHS) or WHO(11). Since such indices may not reflect racial, social and economic differences, using local and regional growth curves are recommended(2).

Therefore by considering the importance of continuous evaluation of growth as a quantitative variable and also, being flexible growth pattern during time and based on the report of the health network on the number children's unsuitable growth who live in Torosk village, the present study aimed to evaluate the quality and children's pattern of growth with age of up to two years in Torosk village in 2004-2006.

## Method

This cross-sectional study was done in 2007. The data was gathered from statistics gathered from all health files of the children. The data gathered from the files contained demographic data of mothers including age, marriage age, education and job as well as the baby's gender, his or her place in the family ,height, weight and head circumference from the birth up to 24 months of age. It should be noted that these children have referred to health center up to 24 months of age.

The criteria for being studied: The children whose age were less than 24 months in years 2004, 2005 and 2006 and have lived in the village during this period . The criteria for leaving the study included evident anomalies, newborn growth disorders and digestive diseases. The method of gathering data of weight, height and head circumference inserted in the children health files were recorded and measured as

100 gr. was used for measuring weight and the children had the least clothes without shoes. The box was used for measuring height and a normal tape was used for measuring head circumference. The employee working in Torosk health center was not changed within the last 10 years before the study started and all the measurements were done by the same person during this period. The economic status of the children' families as well as the food materials available in their homes were also evaluated in the study. The basis for comparing the children growth in this study was NCHS standard. The third, fifth and 97<sup>th</sup> percentiles of growth (height, weight and head circumference) of the children were compared with their counterpart NCHS standard. The height and weight diagrams were drawn for these percentiles. Moreover, the diagram of the ratio of children below third percentiles of standard NCHS was also drawn. The data for growth (Height, weight and head circumference) for each month of their life from the date of birth up to 24 months of age were included in the study. The descriptive indices and growth percentiles of these children were analyzed by SPSS15 and growth diagrams were drawn by EXCEL software.

## Result

135 children were studied in the study including 64 girls (47.4%) and 71 boys (52.6%) 54 children (40%) were the first child of their families and 43 children (31.9%) were the second child and 16 children (11.9%) were the third child and only 16.3% were the fourth child or more. Mother's average age was  $29.71 \pm 6.56$  and fathers average age was  $31.69 \pm 7.80$ . 21 of mothers (15.6%) were illiterate, 105 (77.7%) had elementary education and only 8.2% had junior high school studies or higher. 18 of the fathers (13.4%) were illiterate, 78.4% had elementary education and 8.2% had junior high school studies or upper. None of parents had academic education. 133 mothers (98.5%) were housewives and only two were economically active. 85 of fathers (63%) were farmers, 12 fathers (8.9%) were livestock breeder and 27.6% were busy in other jobs. The economic statuses of the studied

**Table 1. Frequency Distribution and percentage of children below Third percentile of NCHS Growth standarad**

	Below third standard percentile of Weight	Below third standard percentile of height	Below third standard percentile of Head circumference
At birth	10(19.2)*	4(7.7)	4(7.7)
One-month children	4(7.7)	3(5.8)	3(5.8)
Six-month children	5(9.8)	8(15.7)	2(3.9)
Ninth-month children	16(32.7)	8(16.3)	2(4.1)
Twelve-month children	24(53.3)	6(13.3)	1(2.2)
Eighteenth-month children	22(64.7)	7(20.6)	2(6.3)
Twenty-four-month children	10(43.5)	6(26.1)	1(5.9)

\* number (percent)

follows. Seca scale made in Germany with accuracy of

families were poor and

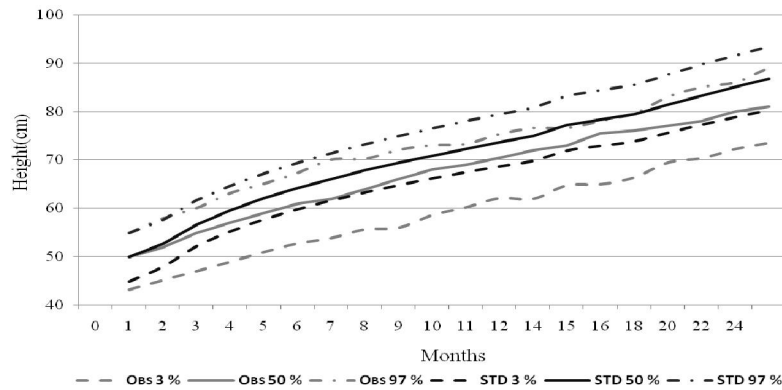

**Diagram 1) The diagram of 3<sup>rd</sup>, 50<sup>th</sup> and 97<sup>th</sup> percentiles of boys' height (cm) in the first two years of age compared with NCHS standard percentiles.**

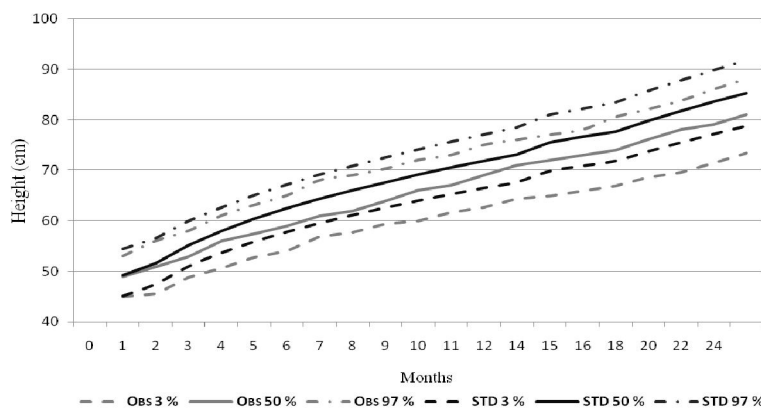

**Diagram 2) The diagram of 3<sup>rd</sup>, 50<sup>th</sup> and 97<sup>th</sup> percentiles of girls' height (cm) in the first two years of age compared with**

they normally faced inadequacy of foodstuffs. Housewives spent a short time of the year in other parts for cultivation, or harvesting agricultural crops or livestock breeding and granted their little children to their disabled or less able grandparents or their adolescent sisters and brothers or sometimes to their neighbors.

The results of studying children at the time of birth during 2004 to 2006 showed that 19.2% of the children (girls and boys) were below third NCHS standard percentile and weight. This ratio was (7.7%) in height and head circumference and had a better condition compared to weight Table 1. The ratio of children with the weight below third percentile of weight standard was higher in older ages as it was 53.3% in 12 month-children and 62% in 18-month children. Generally speaking height had a better condition compared to weight and corresponding percentages in the ages under study were lower. However these percentages which are expected to be near 3% are much higher and got higher in upper ages as the children reached 24 of months. In investigating the variable of head circumference and comparing it with third standard NCHS percentile a more suitable

condition in weight and height variables and the percentages were so much approximate to 3% (Table 1).

In investigating boys' height percentiles it was found that in any of the percentiles height at birth is very close to standard percentile while as the age increases the distance of these percentiles goes farther than their corresponding percentile and the status of growth in this index gets worse. The third percentile has gone farther from standard values than two percentiles of 50<sup>th</sup> and 97<sup>th</sup>. (Diagram 1) Investigating girls' percentiles the same condition was seen (Diagram 2). Investigating the diagram of children' weight showed similar diagrams for girls and boys as the 3<sup>rd</sup>, 50<sup>th</sup> and 97<sup>th</sup> were very close to their corresponding NCHS standard percentiles. But the weight percentiles go far away from their corresponding percentiles. This event is much more evident in the ages above 12 months as it can be seen that in 15 months of age and more the children' weight 97<sup>th</sup> percentile drops down to below 50<sup>th</sup> percentiles and this is the same for boys and girls (Diagram 3&4).

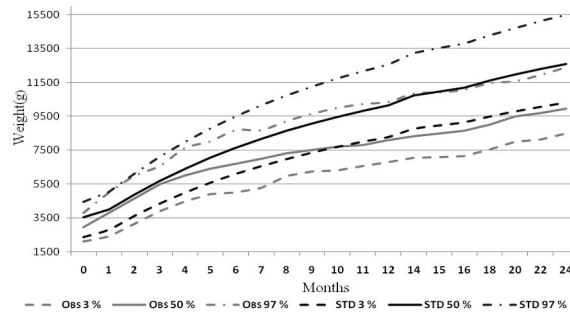

**Diagram 3)** The diagram of 3rd, 50th and 79th percentiles of boys’ weight (gr) in the first two years of age compared with NCHS standard percentiles.

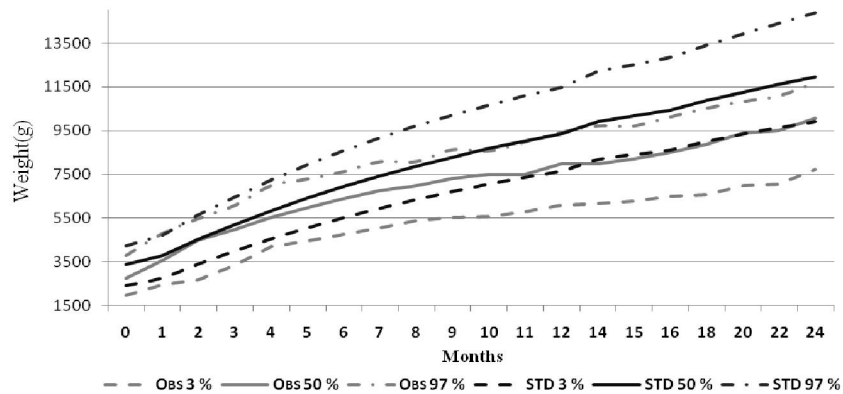

**Diagram 4)** The diagram of 3rd, 50th and 79th percentiles of girls’ weight (gr) in the first two years of age compared with NCHS standard percentiles

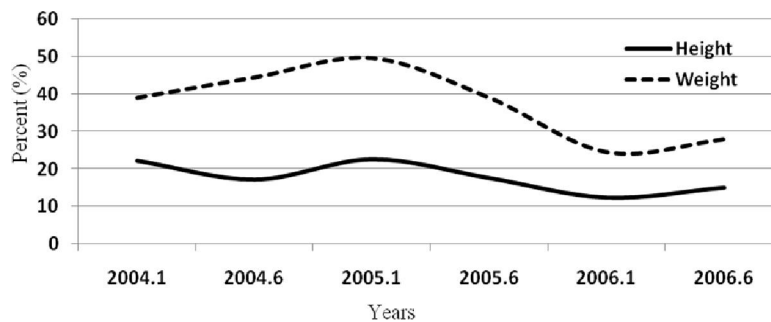

**Diagram 5)** The proportion ratio of children below NCHS standard percentiles in 2004 to 2006.

Studying general condition of height and weight during three years of study shows a sinus process in the status of the children. That is, the ratio of children below third percentile of growth in the first months of the year 2006 increased in weight and this increase reached to its highest level in the first months of 2005 and then decreased up to the ending months of the year 2006 and some growth can be seen in children below third percentile of weight. Studying children below third percentile of height also shows ups and downs similar to weight. The most ratio of the children below third percentile in height is in the early months of the

year 2005 and then decreases. Generally, the status of height based on the ratio of children below third percentile of age and weight is much better than the status of their weight (Diagram5).

**Discussion**

The findings show that 19.2% of the newborn, 7.7% in the first month, 9.8% in six month, 32.7% in 9 months, 53.3% in 12 month, 64.7% in 18 month and finally 43.5% in 24 month had a weight below third standard NCHS percentile .This generally shows the worsening condition of weight gaining of



the children as their age increased specially after adding additive food to the infant's diet. Considering the severe poor economic condition of the region under study and parents' low level of education (none had academic education) and also children being kept by disabled or less-able people (disabled grandparents or adolescent sisters and brothers) or neighbors because their parents' inevitable migration, can be considered as probable reasons for this severe drop in growth. In the studies made by Hop *et al* on Vietnamese children (12) Yong *et al.* in Hon Kong (13) and Katto *et al.* In Japan (14) the delay in children's weight gaining stated from 6 to 12 month and continued up to 24 months of age. In the study made by Ferira *et al* made in 2006 on Brazilian rural children, all children below six months of age had a weight proportional with their age but 15.45% of children between 6 to 12 months of age and 20% of 12-24 months of age had an inadequate weight against their age (15) some studies have shown that the weight or even height of urban children was higher compared to rural children. This can be due to reasons such as higher level of literacy, easier access to health and treatment services, easier access to complements and other required materials and things like that. In the study made by Engvin *et al.* in Vietnam, the weight of urban girls and boys between 3 months of age up to 12 months were 3.4 to 4.1% respectively and 7.2 to 10.5 % higher than rural boys and girls. The height of urban newborn was a little higher than rural newborn (16). In the study made by Ghamkhar *et al* made in Ahvaz none of the newborn children had a weight below third standard percentile but in their six months of age 0.8% of the boys and 1.8% of the girls, in 12 months of age, 1.7% of the boys and 4.1% of the girls, in 18 months of age, 10.8% of the boys and 2.2% of the girls and finally in 22 months of age 0.8 % of the boys and 7.4% of the girls had a weight below third percentile of standard(1). This is consistent with the results gained by this study from severe drop in growth from the age additive nutrition starts. However, the drop in weight gaining in their study was lower than the present study which can be due to reasons like the urbanization of community being studied, parents' different levels of education, (In the said study 45% of the studied mothers had secondary or academic education) In the study made by Hajian *et al.*, (2) made in rural regions of Babol, the range of weight under third standard percentile in children between 1 to 24 months of age was at least 0.55 and at most 4.3% which is sharply different from the present study. The reasons previously mentioned such as low economic condition of the region being studied and parents' low level of education can explain this difference.

The findings of the study showed that 7.7% of the newborn, 5.8% in first month of age, 15.7% in six

months of age, 16.3% in their 18 months of age and 26.1% in 24 months of age had a height below third NCHS standard percentile. Obviously, the least difference of weight with third standard percentile is at birth. Then gradually the inappropriate growth in height increases. In Ferira *et al* short stature compared to age did not exist in children below six months of age. But in ages between 6 to 12 months, it was 30.8% and in 12 to 24 months of age it was 20.8% (15). In the study made by Lorenko *et al.* made on urban Brazilian children in Amazon region, 19% of the children at birth to 5 months of age and 8.5% of the children in 12-23 months of age had short stature compared to their age but the children between 6 to 12 months of age had a height fit for their age(17). Since in the said studies, the height parameters are considered in relation to age, it is not possible to have a suitable comparison with the community being studied in the present study made according to NCHS standard percentiles. In another study made by Kangsim *et al* on Chilean children, only 3% of one-year old children had a height lower than fifth standard percentile(18). This is highly different from the present study. In the study made by Ghamkhar *et al* the number of children below third standard percentile in height evidently increased with increase in age. As 2.2% of the newborn boys and 1.2% newborn girls and in six months of age 1.7% of the boys and 10% of the girls, in 18 months of age, 4.7% of the boys and 13.5% of the girls had a height below third NCHS standard percentile(6). Showing a drop in height growth similar to the present study. However, this drop is sharper in the present study which can be due to reasons like financial affordability, level of education and different weight and head circumference at the time of birth. The study findings indicate a better condition of the children being studied from size and growth of head circumference as 7.7% of the newborn children had a circumference below third standard percentile. This amount reached 5.8%, 3.9%, 4.1%, 2.2% and 6.35 in first, six, 9, 12 and 18 months of age. In the study made by Bolurian *et al* made on children below one year of age in Sabzevar, the head circumference of 14% of the children was below NCHS third standard(19). In the study made by Namakin *et al* on children 1-24 months of age in Brigand, the head circumference percentile of the children being studied conformed to NCHS percentiles (20).

## References

1. Ghamkhar M., Mohammadi M., Ansarimoghadam A., A Survey of Anthropometric Indices Children under 2 years old in Ahvaz city 1382, Journal of Medical Sciences, 2008, vol (7), 2, 188-195[Persian]
2. Hajian K, Sajjadi P, Âlipour A, Habibian N, A

- study on the growth of children from birth up to the age of two years in rural communities of Babol, 1998, J Mazandaran Univ Med Sci 2002, 12(34): 57-69[Persian]
3. Nursing College (Children Group) of Shahid Beheshti University. Child in patient. Tehran: Noor Danesh. 2000, [Persian]
  4. Omidi A., Mahjub H., The Growth Trend of 0–6 Years Children in Hamadan City , Iran, Scientific Journal of Hamadan University of Medical Sciences & Health Services, 2003, 10(2), 46-54[Persian]
  5. Panahi H., Pediatrics value points, Boshra publication, Tehran, 1996[Persian]
  6. Rajabi MT, Rajabi MR, Nelson Essentials of Pediatrics 2002, Tehran, Andishe Rafee Press, 2004 [Persian]
  7. Barak M, Azari Namin L, Abasgolizadeh N, Mirzarahimi M, Sedigh A. Failure to thrive risk factors among children in Namin - Ardebil. J Ardebil Med Sci Univ 2004; 3(10): 18-26. (Persian)
  8. Omidi A., Mahjoub H., The growth trend of 0-6 years children in Hamadan city, Iran,
  9. Scientific Journal of Hamadan University of Medical Sciences & Health Services, 2003, Vol. 10, No. 28 [Persian]
  10. Nakhshab M, Nasiri H, A study on the prevalence rate of malnutrition and it's effective factors in children under two years in sari township 1999-2000, J Mazandaran Univ Med Sci 2002, 12(34): 47-58[Persian]
  11. Taheri F, Fesharaki Nia A, Saadat Joo SAR, Determining the weight and height in 7-12 years old children in Birjand and its comparison with NCHS standard, Journal of Birjand University of Medical Sciences, Vol. 7, No. 12, 33-37[Persian]
  12. Vali Zadeh M, Sohbati Loo F, Mousavi Nasab N , A Survey of Anthropometric Indices [Weight, Height, and Body Mass Index (BMI)] in Secondary School Girls of Zanjan 2004-2005, Journal of Zanjan University of Medical Sciences & Health Services, Vol. 13, No. 52, 30-36[Persian]
  13. Hop LT, Gross R, Giay T, Schultink W, Thuan BT, Sastroamidjojo S. Longitudinal observation of growth of Vietnamese children in Hanoi, Vietnam from birth to 10 years of age. Eur J Clin Nutr, 1997; 51(3):164-71.
  14. Leung SS, Chan SM, Lui S, Lee WT, Davies DP. Growth and nutrition of Hong Kong children aged 0-7 years. Journal of Pediatrics Child Health. 2000;36 (1):56-65.
  15. Kato N, Takaishi M. A longitudinal study of the physical growth of Japanese children. Ann Hum Biol, 1999;26(4):353-63.
  16. Ferreira AA, Welch JR, Santos RV, Gugelmin SA, Coimbra CE. Nutritional status and growth of indigenous Xavante children, Central Brazil. Nutrition Journal, 2012; 11:3
  17. Nguyen HT, Eriksson B, Nguyen LT, Nguyen CT, Petzold M, Bondjers G, et al. Physical growth during the first year of life. A longitudinal study in rural and urban areas of Hanoi, Vietnam. BMC Pediatrics 2012, 12:26.
  18. Lourenço BH, Villamor E, Augusto RA, Cardoso MA. Determinants of linear growth from infancy to school-aged years: a population-based follow-up study in urban Amazonian children. BMC Public Health, 2012;12:265
  19. Kang Sim DE, Cappiello M, Castillo M, Lozoff B, Martinez S, Blanco E, et al. Postnatal Growth Patterns in a Chilean Cohort: The Role of SES and Family Environment. International Journal of Pediatrics, 2012; Article ID 354060, 8 pages
  20. Bolourian Z, Koushki A, Akaberi A, Baghbani M, Baghani M. Study of the Anthropometric Indexes in Children of up to One Year in Sabzevar, Iran in Comparison with NCHS in 2005, Quarterly Journal of Sabzevar University of Medical Sciences, 2008; 14 (4) :231-237[Persian]
  21. Namakin K, Saadat Joo SAR, The comparison of growth charts in 1-24 months old children of Birjand with NCHS reference nomograms, Journal of Birjand University of Medical Sciences, 2002, Vol. 9, No. 14, 5-9[Persian]

10/5/2012

## A New Algorithm for Detecting the Correctness of Merging Operation in Workflow

<sup>1</sup>Homayun Motameni, <sup>2</sup>Somayeh gilani, <sup>2</sup>Fatemeh Zahra naderi and <sup>3</sup>Behnam Barzegar\*

<sup>1</sup>Department of Computer Engineering, Sari Branch, Islamic Azad University, Sari, Iran

<sup>2</sup>Science and Research branch, Islamic Azad university of Mazandaran, Iran

<sup>3</sup>Department of Computer Engineering, Nowshahr Branch, Islamic Azad University, Nowshahr, Iran

\*Corresponding author: Behnam Barzegar

E-mail: [behnam.barzegar@yahoo.com](mailto:behnam.barzegar@yahoo.com) or [barzegar@iauns.ac.ir](mailto:barzegar@iauns.ac.ir)

**Abstract:** Business process in organization are defined as set of connected operations which have determined start and end, definitive purpose and created certain additive value for organization. Thus, modeling business process and developing it has significant importance on changing organization structure and turning them into the successful one. As Petri Nets are strong modeling tool and have graphical and formal base, we model workflow using Petri Nets. Furthermore, in this paper, we discuss workflows merging and offer a method for merging business process. This leads to decrease in cost and time in large organizations. However, if merge be correct, as there is no official investigation about correctness of merging operation, thus in this paper we aim to present an algorithm using vicinity matrix in order to determine correctness of merging operation.

[Homayun Motameni, Somayeh gilani, Fatemeh Zahra naderi and Behnam Barzegar. **A New Algorithm for Detecting the Correctness of Merging Operation in Workflow.** *Life Sci J* 2012;9(4):1759-1768] (ISSN:1097-8135). <http://www.lifesciencesite.com>. 268

**Keywords:** Workflow, Merging, Petri Net, Workflow.

### 1. Introduction

Processes are set of integration operations which follow definitive and unique purposes and provide facilities for organizations. In recent years, modeling business process and developing it has become one of important strategies for changing organization structures and turning them into the successful organizations with high competition potential.

Business process is set of horizontal processes which are joined to perform various basic actions through them output of related organizations are made. In fact, a business process is net of active connections and well-defined buffers and superior communication which use resources for turning inputs into outputs in order to satisfy customer demands and get their agreement.

A comprehensive approach in direction of business process should record a business process, provide required tools for identifying bottlenecks and bind points and analyzing them, and finally improve business process based on determined purposes. Successful modeling business process depends on choosing appropriate technique for analyzing workflow.

In this paper, we use Petri Nets as a modeling tool, because it displays a process in graphical and formal method and allow us to analyze with more details.

For agile business operation, modern corporations must make frequent business process changes as well as organizational changes through merges and acquisitions. For example, in 2001, Hewlett-Packard Company and Compad Computer Corporation were

merged. The company merged offers set of production and services in IT industry and saved cost using merging operation has estimated 2.5 billion dollars in year [6]. Important problems have created for large companies through merging. One of these problems is recognizing correctness of merging operation, cause if merging be incorrect, not only leads to decrease in cost and time, but also increase them. Thus, in this paper we aim to present new algorithm for recognizing correctness of merging operation. Idea of this algorithm has derived from vicinity matrix, due to having mathematical basic, is easy implementations and understandable. We could evaluate correctness of operation before perform merging operation using this algorithm and save in cost and time. As this is new trend, many of merging operations don't save cost and time, and even increase them.

The organization of this paper as follows:

In section 2 we present related works. In section 3 we introduce basic workflow concepts. Then, in section 4 we state mapping workflow concepts onto Petri Nets. In section 5 we will discuss merging workflow and merging methods. In section 6 we analyze merging operation and present an algorithm for recognizing correctness of merging operation. And finally in section 7 we will conclude our text.

### 2. Related works

Successful modeling business process depends on available appropriate modeling method for analyzing workflow process. There are many analyzing methods, such as workflow diagram, dataflow

diagram, the integrated definitions of function modeling, the extendible markup language (XML), Petri Nets, object-oriented methods, which are used.

In [1] workflow has implemented with UML activity diagram, also investigate the expressiveness and the adequacy of activity diagrams for workflow specification, by systematically evaluating their ability to capture a collection of workflow patterns.

In [7], BPMN introduced as new standard which has developed for modeling business process. This process has formulated in consensus of BPMI Notation working group members, which include main part of business process modeling society. BPMN has several advantages than UML: first, BPMN presents technique for modeling process current which is closer to underused method for business process modeling. Second, UML has steady and complete mathematical foundation which has designed for executive business language, while UML doesn't have this advantage.

As business on Internet needs that business partners exchange information about their business processes in an automated manner, thus authors in [2] has proposed the design for an exchangeable routing language (XLR) using XML syntax. XML (extendible markup language) is a means for trading partners to exchange business data, electronically. Also, XML could support describe workflow process schemas, which through it we could analyze correctness and performance of workflows described in XRL.

As Petri Nets are an established tool for modeling and analyzing processes. One the one hand, they can be used as a design language for the specification of complex workflows. Also, Petri Nets theory provides powerful analysis techniques which can be used to verify the correctness of workflow procedures.

In [3] a last has implemented workflow concepts using Petri Nets.

In [4] workflow modeling methods such as Petri Nets, WFMC, UML, ANSI and EPC have compared based on criteria such as formal basis, executability, ease visualization, etc. their Study showed that Petri Nets satisfied most of the criteria, and were therefore desirable.

### 3. Basic workflow concepts

Figure 1 shows that a workflow has three dimensions: (1) the case dimension, (2) the process dimension and (3) the resource dimension. Workflows are case-based, i.e. every piece of work is executed for a specific case. A case is the thing which needs to be processed by following the process definition. Examples of cases are a mortgage, an insurance claim, a tax declaration, an order, or a request for information. Each case has a unique identity and a limited lifetime [3].

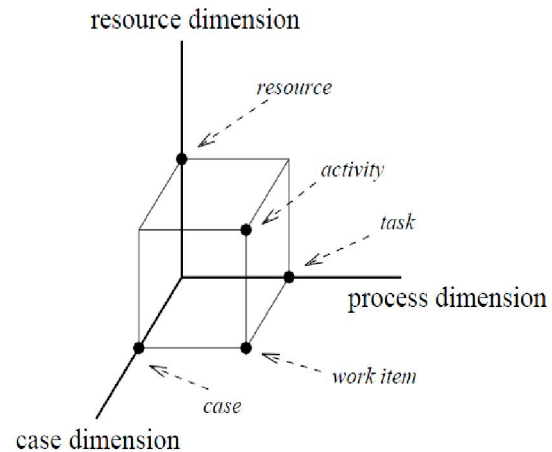

Figure 1: A three dimensional view of a workflow

In the process dimension, it is specified which tasks need to be executed and in what order. A task is a logical unit or a generic piece of a work.

In the resource dimension, the resources are grouped into roles and organizational units.

We can visualize a workflow as a number of dots in the three dimensional view shown in figure1. Each dot represents either a workitem (case+resource) or an activity (case+task+resource).

Since Petri Nets are a process modeling technique and the application is restricted to the first two dimensions, in this paper we focus on the first two dimensions.

### 4. Mapping workflow concepts onto Petri Nets

In this section, first we introduce Petri Nets and then using it we present a definition for workflow net. Next, we illustrate workflow modeling using Petri Nets with an example.

Petri Net is a mathematical method for modeling and evaluating software productions, which first was introduced by Carl Adam Petri in 1962. Petri Net offers obvious and precious concepts and understandable graphical notations and many analytical techniques. Petri Nets are based on graphs. In fact, idea of graphs caused that Adam Petri achieved to Petri Nets models.

All constructs in a Petri Net can be demonstrated mathematically and furthermore, the formallism can illustrate cases by use of tokens that move through the net (Petereson, 1981). The use of these tokens therefore makes the net executable and very well adapted to simulation (Reisig, 1985). Now, we offer a formal definition for Petri Nets.

**Definition (1) Petri Net:** Petri Net structure have consisted five components of  $C = (P, T, I, O, M_0)$  where:

- P denotes finite set of places;
- T denotes finite set of transitions;
- I denotes set of input functions for net transitions;
- O denotes set of output functions for net transitions; and
- $M_0$  denotes initial state of net which determine number of tokens in places. Graphical notations consist three components for business process and now is a formal model for workflow (Van 1998, Dar Adlst [4]).

**Definition (2) Petri Net:** a Petri Net is a triple  $(P, T, F)$ :

- P is a finite set of places,
- T is a finite set of transitions ( $P \cap T = \emptyset$ )
- $F \subseteq (P \times T) \cup (T \times P)$  is a set of arcs (flow relation)

A place p is called an input place of a transition t if there exists a directed arc from p to t. Place p is called an output place of transition t if there exists a directed arc from t to p. We use  $\bullet t$  ( $t\bullet$ ) to denote the set of input (output) places for a transition t. The notation  $\bullet p$  ( $p\bullet$ ) have similar meanings. [3, 5]

**Definition (3) workflow net (wf-net):** a Petri Net  $P = (P, T, F)$  is a wf-net (workflow net) if and only if:

- i. PN has two special places: i and o. place i is a source place:  $\bullet i = \emptyset$ . Place o is a sink place:  $o\bullet = \emptyset$ .
- ii. If we add a transition  $t^*$  to PN which connects place o with i (i.e.  $\bullet t^* = \{o\}$  and  $t^*\bullet = \{i\}$ ), then the resulting Petri Net is strongly connected [3, 5].

A Petri Net which models a workflow process definition is called a workflow net (WF-net) [3, 5].

**4.1. modeling workflow with Petri Net**

Tasks are modeled by transitions, conditions are modeled by places, and cases are modeled by tokens [3]. for example in figure 2 [3] models complaint handling process.

An incoming complaint is recorded, then the client and the department affected are contacted (can be done in parallel), afterwards, the data are gathered and a decision is taken either (1) a compensation payment is made, or (2) a letter is sent. Finally, the complaint is filed.

**4.2. Routing of cases**

Describes the lifecycle of a case, i.e., which tasks need to be performed and in which order. we have four types of routing:

- Sequential
- Parallel
- Conditional
- Iteration

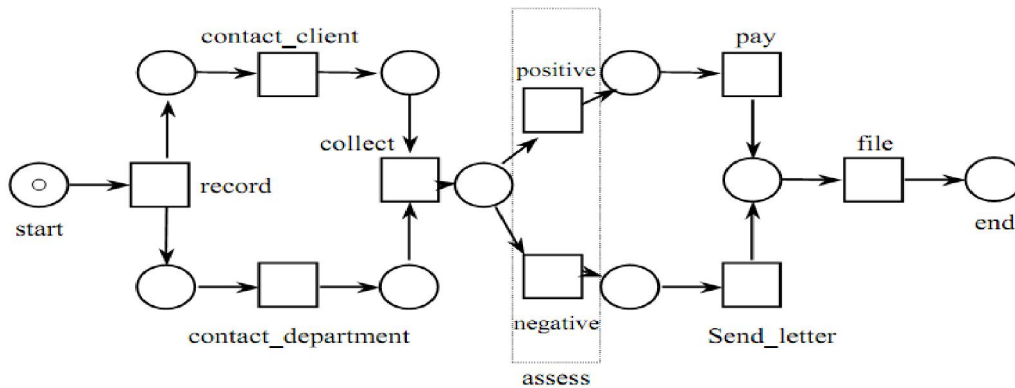

Figure2: modeling complaint handling as a Petri Net

**4.2.1. Sequential routing**

Sequential routing is used to deal with causal relationships between tasks. Consider two tasks A and B .if task B is executed after the completion of task A, then A and B are executed sequentially [3].

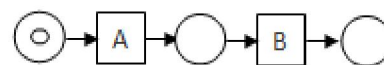

Figure 3: Sequential routing

**4.2.2. Parallel routing**

Parallel routing is used in situations where the order of execution is less strict. For example, two tasks B and C need to be executed but the order of execution is arbitrary. To model such a parallel routing, two building blocks are used: (1) the AND-split and (2) the AND-join [3].

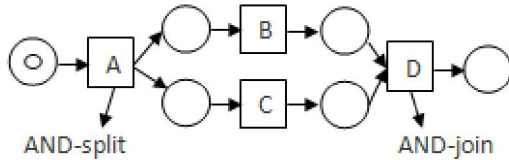

Figure 4: Parallel routing

**4.2.3. Conditional routing**

To model a choice between two or more alternatives we use two building blocks: (1) the OR-split and (2) the OR-join. Figure 5 [3] shows the situation where task A is followed by either task B or task C, i.e., a choice is made between B and C.

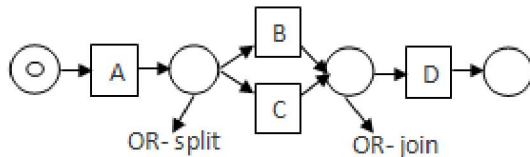

Figure 5: conditional routing

**4.2.4. Iteration routing**

In the figure 6[3] task B is executed one or more times.

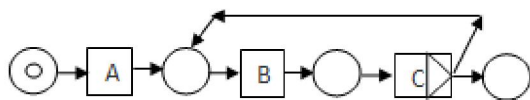

Figure 6: Iteration routing

**5. Workflow merging**

In this section, we introduce workflow merging concepts and type of merging methods.

**5.1. Concepts of workflow merge**

We define workflow merge as the process of combining one workflow schema into another and removing redundant steps but keeping all necessary ones [6].

**Definition (4) Workflow Merge.** When a WF-net  $PN' = (P', T', F')$  is combined with another WF-net

$PN = (P, T, F)$ , we call the process a workflow merge, if and only if:

- (i) The result is a new WF-net  $PN'' = (P'', T'', F'')$
- (ii)  $T'' \subseteq T \cup T'$
- (iii)  $P'' \subseteq P \cup P' \cup P_m$  (where  $P_m$  are new merge points)
- (iv)  $F'' \subseteq F \cup F' \cup (T'' \times P_m) \cup (P_m \times T'')$

We call the merge function as  $Merge(PN, PN')$ , and we call  $PN$  the primary WF-net and  $PN'$  the secondary WF-net.

According to condition (ii), the merged workflow should not involve any new tasks that are not in the merging workflows; condition (iii) ensures that only result merge points can include new conditions; condition (iv) states that dependencies in the merging workflows should be compliant with the ones in merged workflows [6].

**Definition (5) Merge Point.** When a primary WF-net,  $PN' = (P', T', F')$ , is merged with a secondary WF-net,  $PN = (P, T, F)$ , and the merged workflow is a WF-net,  $PN'' = (P'', T'', F'')$  a place node such as  $p \in PN$ ,  $p' \in PN'$  or  $p_m \in PN''$  is called a merge point, if and only if:

- (i) If  $p \in PN \cap PN''$ ,  $\exists t$  such that  $t \in (\cdot p \cup p \cdot) \wedge t \in PN'$ , or
- (ii) If  $p' \in PN' \cap PN''$ ,  $\exists t$  such that  $t \in (\cdot p' \cup p' \cdot) \wedge t \in PN$ , or
- (iii)  $p_m \in PN \cup PN'$

The place nodes where two merging workflows, say  $wf1$  and  $wf2$ , are connected are called merge points. Merge points are always in pairs and they are noted as  $(p/p')$  which means that  $p'$  from  $wf2$  will merge with  $p$  from  $wf1$  [6].

For example, Fig. 7[6] depicts a merge function  $Merge(PN, PN')$ , and the merged workflow is  $PN''$ . Because, in a Petri Net, two place nodes (such as  $p2$  and  $p0'$ ) cannot be connected directly without a transition node in between.

By eliminating redundant nodes ( $p2$ ) and auxiliary node ( $tx$ ) we can reduce  $PN''$  into  $PN'''$ . This is a workflow simplification step. We will explain it in next section.

**5.2. Type of workflow merging**

Whereas workflows have basic process patterns, such as sequential, parallel, conditional, and iterative. In basic merge situations, we assume that two merging workflows contain a single pattern in the merged workflow and two pairs of merge points: A pair of beginning merge points and a pair of ending merge points. within this condition we define sequential, parallel, conditional, and iterative workflow in. In more complex situations, a merged workflow may

contain multiple merge points. However, a complex merge can be represented by combining simple merge patterns.

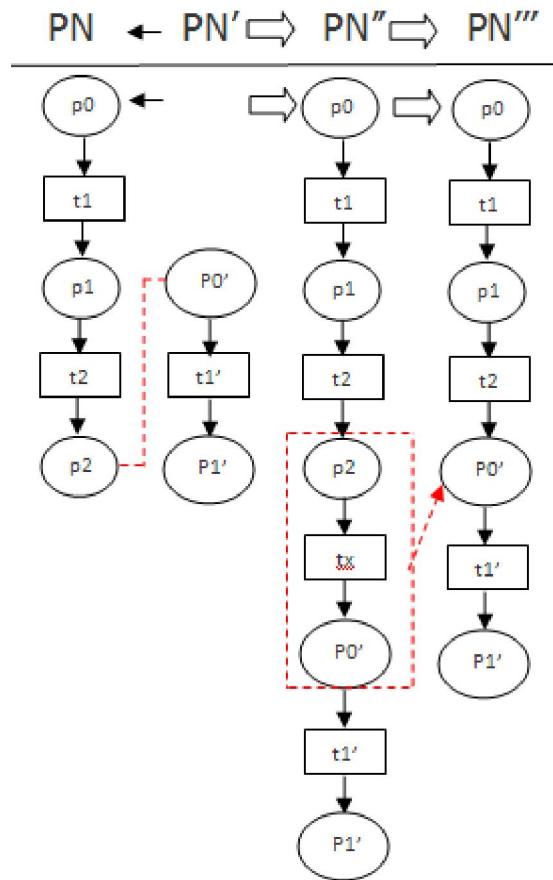

Fig.7. Workflow merge example.

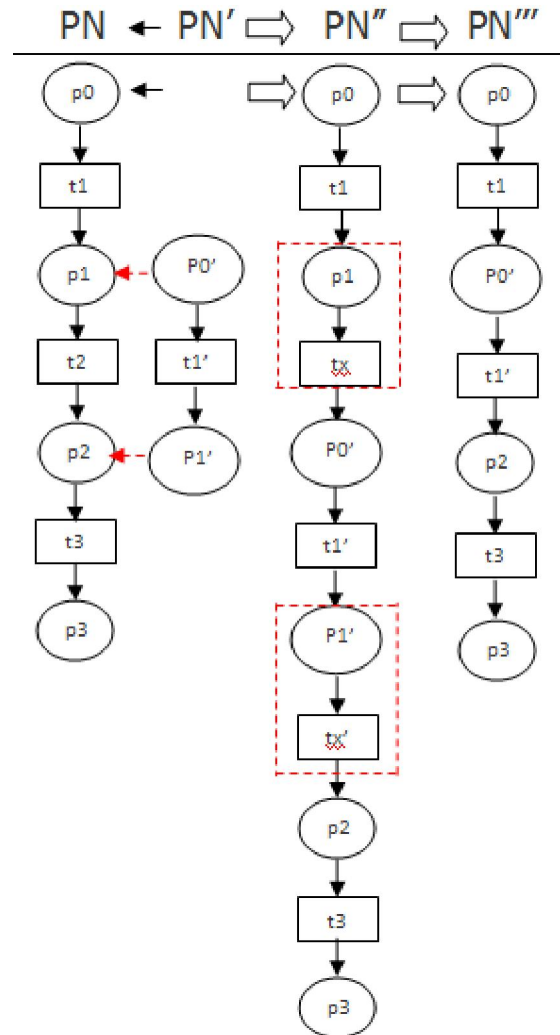

Fig.8.Replacement Merge.

**Definition (6) Sequential merge.** When two workflows, PN and PN', merge at merge points (p1/p1', p2/p2'), if p1 is replaced by p1' and p2 by p2', it is a sequential merge. The tasks or steps of PN between p1 and p2 are replaced by the steps in PN' between p1' and p2'. In general, no new place nodes are created in a sequential merge [6].

There are two types of sequential merges:

1. Replacement merge
2. Insertion merge.

Fig. 8[6] shows a replacement—Merge\_Seq (PN, PN', p1, p0', p2, p1')

where t2 is replaced by t1'. Fig. 9[6] shows an insertion—Merge\_Seq (PN, PN', p1, p0', p1, p1')

where, in the primary workflow, place p1 is both the start place and the end place.

A sequential merge involves two steps: initial merge and simplification.

In the first step, the merging workflows are combined through two pairs of auxiliary-node sets at the merging points. In Fig. 8, an auxiliary node, tx, is connected to the merge point, p1, while another auxiliary node tx' is connected to p2. As discussed above, the auxiliary transition nodes are required to connect two place nodes in a Petri net. Between the auxiliary node is the merge region of PN'. The use of the auxiliary nodes in the merge guarantees a sequential relation between the merging workflows.

To simplify and make the workflow nets concise, we need to eliminate the redundant nodes and auxiliary transitions.

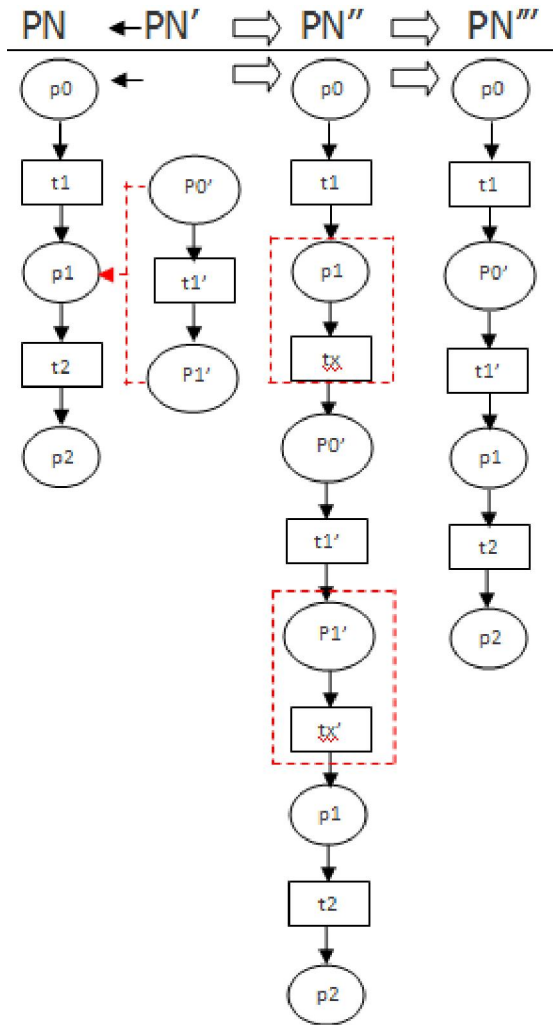

Fig. 9. Insertion Merge.

In both Figs. 8 and 9, PN'' represents the result of the initial merge and PN''' is the result after simplification. It is easy to see that PN'' and PN''' are equivalent. However, because the auxiliary nodes are not essential in the final merge result, we provide an algorithm that obtains the merged workflow without involving any auxiliary nodes.

**Algorithm (1) Merge\_Seq[6].**

Algorithm Merge\_Seq(PN,PN',p1,p1',p2,p2')

1. Remove p1, the arcs after p1, and the arcs before p1'.
2. Connect \*p1 to p1' (i.e., connect the input transitions of p1 to p1' with new arcs).
3. Remove \*p2, arcs before p2, and arcs after p2'.
4. Connect \*p2' to p2 (i.e., connect all input transitions of place p2' to the place p2 with new arcs).

5. The process that contains p1' and p2 is the merged workflow.

**Definition (7) Parallel Merge.** When two workflows PN and PN' merge at merge points (p1/p1', p2/p2'), if, after the merge, p1 and p1' construct an AND-split and p2 and p2' construct an AND-join, it is a parallel merge, i.e., PN and PN' have been connected at points p1/p1' and p2/p2', in parallel. In general, no new place nodes are created in a parallel merge.

**Algorithm (2) Merge\_Par[6].**

Algorithm Merge\_Par(PN, PN', p1, p1', p2, p2')

1. Remove the arcs before p1' and connect \*p1 to p1'.
2. Remove the arcs after p2' and connect p2' to p2\*.

Parallel merges are used when the causal order between the merging workflows is not relevant. Fig. 10 [6] illustrates a parallel merge where the order of tasks t2 and t2' is not relevant.

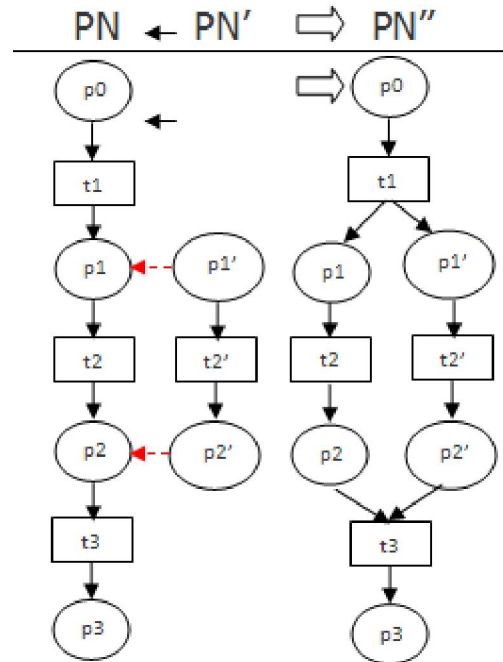

Fig.10.Parallel Merge.

**Definition (8) Conditional Merge.** When two workflows PN and PN' merge at merge points (p1/p1', p2/p2'), if p1 and p1' construct an OR-split and p2 and p2' construct an OR-join, it is a conditional merge, i.e., PN and PN' have been connected at points p1/p1' and p2/p2' with additional conditions. A new place called a condition place will be created in a conditional merge [6].



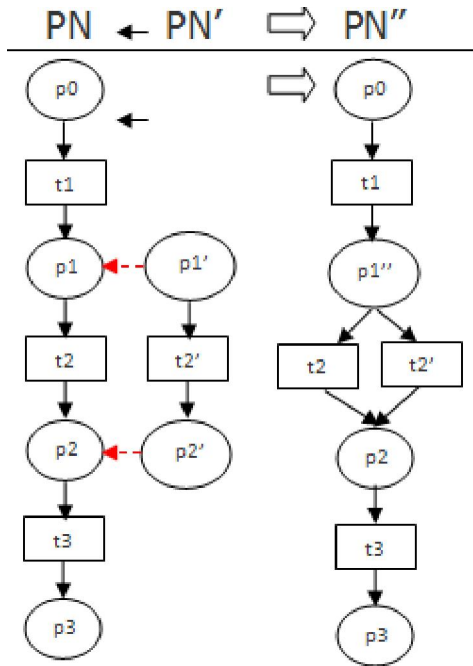

Fig. 11. Conditional merge.

Fig. 11[6] is an example of a conditional merge,  $\text{Merge\_Cond}(\text{PN}, \text{PN}', p1, p1', p2, p2', C)$ . In the merged workflow,  $p1$  and  $p1'$  are merged into a new place called  $p1''$  that contains conditions for choosing between tasks  $t2$  and  $t2'$ . Because the transitions after place  $p2'$  are not included in the result, the conditions in  $p2'$  are useless in the merged workflow. Therefore, the merge point of the secondary merging workflow is removed.

**Algorithm (3) Merge\_Cond[6].**

Algorithm  $\text{MergeCond}(\text{PN}, \text{PN}', p1, p1', p2, p2', C)$

1. Remove the arcs before  $p1'$ , and connect  $p1''$  to  $p1'$ .
2. Remove the arcs after  $p2'$ , and connect  $p2'$  to  $p2$ .
3. Modify the conditions in  $p1$  according to new choice conditions  $C$  and  $p1'$ .

**Definition (9) Iterative Merge.** When two workflows  $\text{PN}$  and  $\text{PN}'$  merge at merge points  $(p1/p2', p2/p1')$ , if  $p1$  and  $p2'$  construct an OR-join and  $p2$  and  $p1'$  construct an OR-split, it is an iterative merge, i.e.,  $\text{PN}$  and  $\text{PN}'$  have been connected at point  $p1/p2'$  and  $p2/p1'$  with additional conditions. A new place will be created in an iterative merge [6].

**Algorithm (4) Merge\_Iterative[6].**

Algorithm  $\text{Merge_Iterative}(\text{PN}, \text{PN}', p1, p2', p2, p1', C)$

1. Remove the arcs before  $p1'$ , and connect  $p2$  to  $p1''$ .
2. Remove the arcs after  $p2'$ , and connect  $p2'$  to  $p1$ .

3. Modify the conditions in  $p2$  according to the new choice conditions  $C$  and original conditions in  $p2$ .

Fig. 12[6] is an example of iterative merge,  $\text{Merge\_Iterative}(\text{PN}, \text{PN}', p1, p2', p2, p1', C)$ . In the merged workflow,  $p2''$  is a new place that contains conditions for choosing between tasks  $t3$  and  $t4$ .

**Definition (10) Complex Merge.** When two workflows  $\text{PN}$  and  $\text{PN}'$  merge at more than two pairs of merge points, it is called a complex merge. A complex merge may involve multiple merge patterns [6].

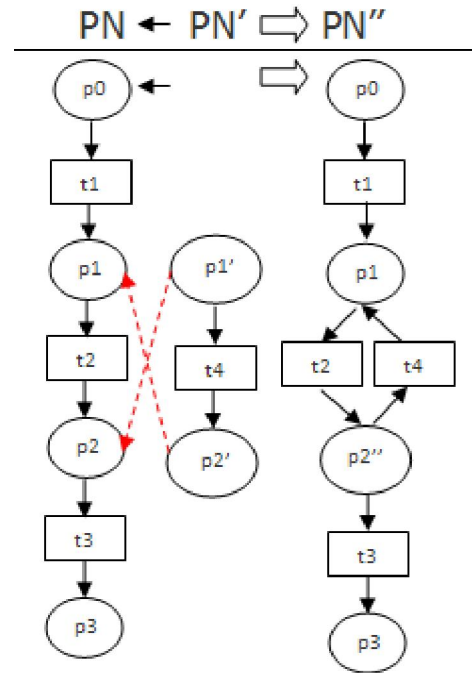

Fig. 12. Iterative Merge.

**6. Workflow Merge Analysis**

Above we discussed various types of functions or operations for merging two workflows. However, without properly chosen merge points and merge functions, two merging workflows cannot yield a sound result, even a syntactically sound one.

Fig. 13[6],  $\text{Merge\_Seq}(\text{PN}, \text{PN}', p4, p6', p7, p1')$ , gives an example of an unsound merged workflow because node  $p5$ , after the merge, becomes dangling, and the whole workflow,  $\text{PN}''$ , is ill structured.

If a workflow merge yields a correct result, we call it a sound merge. On the other hand, in some situations, two workflows cannot be merged correctly, and we call such merges unsound. Fig. 13 shows an unsound merge.

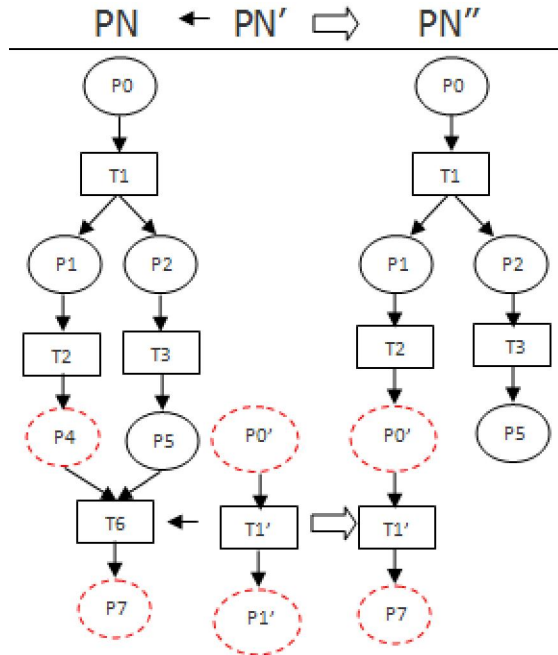

Fig.13. An unsound merged workflow.

**Definition (11) Merge Region.** When two workflows PN and PN' are merged at merge points (p1/p1', p2/p2'), by the operation merge (PN, PN', p1, p1', p2, p2'), the sub-process between p1 and p2 (or between p1' and p2') is called a merge region. The merge region for a merging workflow, say PN (or PN'), can be obtained through the following algorithm:

1. Remove \*p1 and p2\* (or \*p1' and p2'\*).
2. The sub-process that contains merge points p1 and p2 (or p1' and p2') is the merge region for the merging workflow PN (or PN').

**Theorem.** If the merge regions of two merging workflows are structured WF-nets, the merged workflow constructed with sequential, parallel, conditional, and iterative merge functions is structured too [6].

By choosing a proper merge point, we can change an unsound merge to a sound one. In Fig. 14, Merge\_Seq(PN, PN', p3, p1', p5, p2') results in PN'', which is not well-structured. If we change a merge point of PN from p5 to p4—thus, Merge\_Seq(PN, PN', p3, p1', p4, p2'), the new result PN''' is well-structured and sound.

**Algorithm (5): Merging Correctness Detection.** Merging Correctness Detection Algorithm (PN, PN', p1, p1', p2, p2')

1.  $t = *p1$  ;
2.  $t' = p2*$  ;

3.  $t'' = *p1'$  ;
4.  $t''' = p2'*$  ;
5. n1 = number of output arcs t;
6. n2 = number of input arcs t';
7. n3 = number of output arcs t'';
8. n4 = number of input arcs t''';
9. if (n1≠n2) then incorrect merge;
10. else if (n3≠n4) then unsound merge;
11. else correct merge;

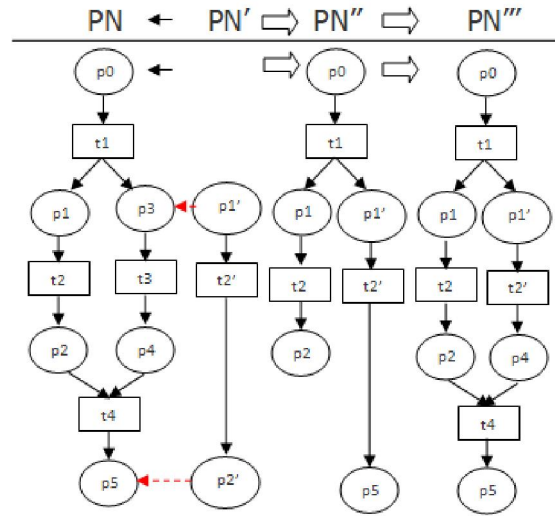

Fig. 14. Example of choosing a proper merge point.

In this algorithm, with considering number of output transition arcs before merge start point and number of input transition arcs after merge end point in each merge workflow, we could find out that whether our merge region is well-structured or not, and if it leads to sound merge or not.

For example consider figure14. In PN workflow, number of output transition arcs before merge start point (t1) is equal 2, whereas number of input transition arcs after merge end point is equal zero (there is no transition). Thus, merge region is not well-structured. Now if merge region is changed to (P3/P4), as you can see, because number of output transition arcs before merge start point (t1) is equal to the number of input transition arcs (t4), therefore selected merge region well-structured and would be sound result merge (PN''').

For convenience it could be used vicinity matrix, such that for highlighting output arc from each transition we could create a vicinity matrix, in which rows indicate transitions and columns show places. If there is an arc from one transition to a place,

corresponding element in vicinity matrix is equal one and otherwise is zero. Last column (SO) indicates sum of output arcs from each transition. Similar to above technique, we create a vicinity matrix for determining number of input arcs towards inside of each transition. If there is an arc from one place to an transition, corresponding element in vicinity matrix is equal one and otherwise is zero. Also, last column (SI) denotes sum of number of input arcs towards inside of each transition. For example consider figure15 shows vicinity matrix PN for figure 14. As SO value in t1 transition equal to SI value in t4 transition, then PN''' merge is correct.

	P <sub>0</sub>	P <sub>1</sub>	P <sub>2</sub>	P <sub>3</sub>	P <sub>4</sub>	P <sub>5</sub>	SO
T1	0	1	0	1	0	0	2
T2	0	0	1	0	0	0	1
T3	0	0	0	0	1	0	1
T4	0	0	0	0	0	1	1

Outer edges from transitions

	P <sub>0</sub>	P <sub>1</sub>	P <sub>2</sub>	P <sub>3</sub>	P <sub>4</sub>	P <sub>5</sub>	SI
T1	1	0	0	0	0	0	1
T2	0	1	0	0	0	0	1
T3	0	0	0	1	0	0	1
T4	0	0	1	0	1	1	2

Inner edges to transitions

Fig.15.vicinity matrix.

As another example, we explain sample of sound merge in hotel management system in figure 16.

Suppose that workflow of room delivery in at a hotel is such that a customer receive his key room in return for paying stay cost. Here we have two workflows for paying stay cost. In first workflow, customer has his travel expenditures with himself and pay cost of his room directly. In second workflow, customer has credit card for the security reasons and as there is no ATM system in the hotel, customer has to receive money from an outside ATM and then deliver it to hotelier and receive his key room. After opinion sampling from hotel customers, hotel managers found out that for those customers who highly care about security problems create new workflow, by which instead of receiving money from an outdoor ATM, place an ATM in the inside of hotel through it payments directly deposit to hotel account.

In figure 16 we illustrate example of replacement workflow merge, in which merge points should be selected correctly. If our merge be as:

Merge\_Seq(PN, PN', "statement payment", "statement payment", "statement has paid", "statement has paid")

Merge is sound, since "statement delivery" transition has two outputs and "key room delivery" has two inputs. According to the algorithm these two are equal and so merge is sound.

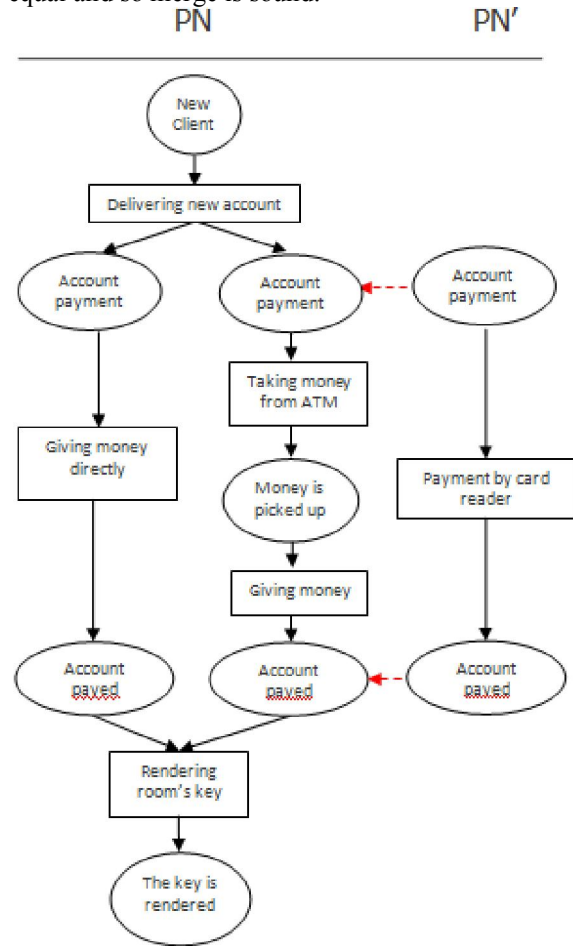

Fig.16.Example of sound merge in hotel management system.

### 7. Conclusion

In this paper we used Petri Net for modeling workflow, because: (1) a workflow process specified in terms of a Petri Net has a clear and precise definition; (2) Petri Net are a graphical language. As a result, it could be learned easily and intuitively; (3) Petri Net support all the primitives needed to model a workflow process; (4) Petri Net has rigid mathematical basic; (5) Petri Nets have marked using many analyzing techniques. These techniques can be

used to prove properties (safety properties, invariance properties, deadlock and etc). (6) Petri Net provide an independent framework for modeling and analyzing processes. Moreover, we discussed about workflow merge and all types of merge methods, which lead to decreases in cost, time and increase in throughput of huge organizations in the case that merge operation be sound. Merge operation would be sound if two selected merge region be well-structured. Merge points are effective in determining being well-structure of merge region, so by selecting suitable merge points created merge region would be well-structured and thus our merge is sound.

#### References

- [1] M. Dumas, A.H.M.t. Hofstede, "UML activity diagrams as a workflow specification language", International Conference on the Unified Modeling Language (UML), springer Verlage,Toronto, Canada, 2001.
- [2] W.M.P.v.d. Aalst, A. Kumar, "XML based schema definition for support of inter-organizational workflow", Information systems Research 14 (1) (2003) 23-47.
- [3] W.M.P.v.d. Aalst, "The application of Petri nets to workflow management", Journal of Circuits, Systems and Computers 8(1) (1998) 21-66.
- [4] A. Dussart,B.A. Aubert, M. Patry, "An evaluation of interorganizational workflow modeling formalisms", Journal of Database Management 15 (2) (2004) 74-104.
- [5] Dongsheng Liu , Jianmin Wang, Stephen C.F.Chan, Jianguang Sun, Li Zhang, "Modeling workflow processes with colored Petri nets", computers in Industry 49(2002) 267-281.
- [6] Shuang Sun, Akhil Kumar, John Yen, "Merging workflows: A new perspective on connecting business processes", Decision Support Systems 42 (2006) 844- 858.
- [7] Reza samizadeh ,marzieh Chapardar , "Standard introduced BPMN. The modeling of business processes"

8/15/2012

## Analysis of hydraulic fracturing length and aperture on the production rate in fractured reservoir

Jaber Taheri Shakib<sup>1</sup>, Abdolvahed Ghaderi<sup>2</sup> and Abbas Abbaszadeh Shahri<sup>3</sup>

<sup>1</sup>Department of Petroleum Engineering, Shahid Bahonar University of Kerman, Iran

<sup>2</sup>Department of Petroleum Engineering, Science and Research Branch, Islamic Azad University, Tehran, Iran

<sup>3</sup>Assistant Professor, Department of Geophysics, Islamic Azad University, Hamedan Branch, Hamedan, Iran

\*Corresponding author: Abbas Abbaszadeh Shahri

E-mail: a\_abbaszadeh@iauh.ac.ir; abbas4646@yahoo.com; Jaber\_Taherishakib@Yahoo.Com.

**Abstract:** Hydraulic fracturing operations are used mainly where the reservoir rock near the well is damaged or reservoirs with low permeability. In the fractured reservoir where the reservoir contains fractures and tracks, in order to connect them to each other, the rate of production should be increased. In this study, a hydraulic fracturing operation in fractured reservoir is investigated. 10 wells for this study with a different distribution of natural fractures are evaluated. Hydraulic fracturing operation in the wells with different length and aperture opening can be applied in any case; the impact of each of these two parameters can be evaluated on production. As we will see in reservoir with a low natural fracture, hydraulic fracture length should be having more and in reservoir with high density from natural fractures, hydraulic fracture height has an important role on the production rate.

[Jaber Taheri Shakib, Abdolvahed Ghaderi and Abbas Abbaszadeh Shahri. **Analysis of hydraulic fracturing in fractured reservoir: interaction between hydraulic fracture and natural fractures.** *Life Sci J* 2012;9(4):1769-1777] (ISSN:1097-8135). <http://www.lifesciencesite.com>. 269

**Keywords:** Hydraulic Fracture, Length, Opening, Natural Fracture, Production Rate.

### Introduction

From the point of oil and gas engineering and exploitation of hydrocarbon reservoirs, increased productivity in the wells, especially in wells with low permeability or damaged wells is one of the main goals. Different ways to increase productivity of wells has been presented that can improve the performance of wells. The most important methods of improving productivity of wells, effect on the reservoir rock physics which is trying to improve the physical structure of reservoir rocks. Among the most important of these methods can be used to create artificial fractures in the reservoir rock. One common method to motivate the wells is creating artificial fractures and Proper use of this method can improve the permeability of reservoir rocks and thus can play an effective role in improving productivity of the wells. In hydraulic fracture, fractures from the wall are created to make the wells producing oil or gas.

The problem of crack deviation at natural cracks or faults has been widely investigated numerically (Zhang and Jeffrey 2006, 2008; Thiercelin and Makkhyu 2007). There are several numerical techniques that are proposed to model such complicated process, some of them are based on finite element method ( Zhang and Ghassemi , 2010), others are based on combining analytical and numerical methods (Weng et al. 2011). However, a comprehensive analysis of how different parameters influence the fracture behavior has not been fully investigated to date. An understanding of the main physical criteria during the interaction of a hydraulic

fracture with pre-existing discontinuities plays an important role in prediction of the propagation scenario (D. A. Chuprakov et al., 2010). Hydraulic fracture length and height are parameters that affect the operation of hydraulic fracturing. In reservoirs with different natural fracture from point of fractures density and their makeup which hydraulic fracture with which features be applied to be the best possible operating efficiency, it will be very important and efficient, as far as the economic discussion of the operations are heavily influenced. Therefore, these two parameters are essential to successful operation of hydraulic fracture. In this study, two parameters in 10-well hydraulic fracture length and height indifferent natural crack density is studied. In each well, Hydraulic fracture with different length and height can be applied and the flow rate is checked at every stage of production. Here it is trying to influence the length and height of hydraulic fracture at fractured reservoir analysis and impact of each on the operations will be discussed.

### Direction of hydraulic fracture

In terms of rock mechanics to create an artificial fracture in the rock can be expressed as: Each type of stone formation in general the amount of power (strength), which depends on rock structure, compaction of the cement stone. Forces that tend to hold the stones together are include Stress on the rocks and strength of stones. When the well is filled with fluid and the pressure of the fluid is left on the surface fluid pressure in the reservoir rock increased.

Hydraulic pressure should be applied equally in all directions. If the pressure is increased to the extent that the force of this pressure is created, impose any additional amount of pressure causes the rock fractures and gaps to be created. The extent of fractures with respect to the fluid pressure that is caused by fluid injection can be controlled. When a stone is placed

under pressure the broken line is formed together with the main stress maximum principle maximum stress and minimum main stress is perpendicular. With the information from the field, the main stress distributions around the every 10 wells are studied and direction of forming the hydraulic fracture is given in Figure 1.

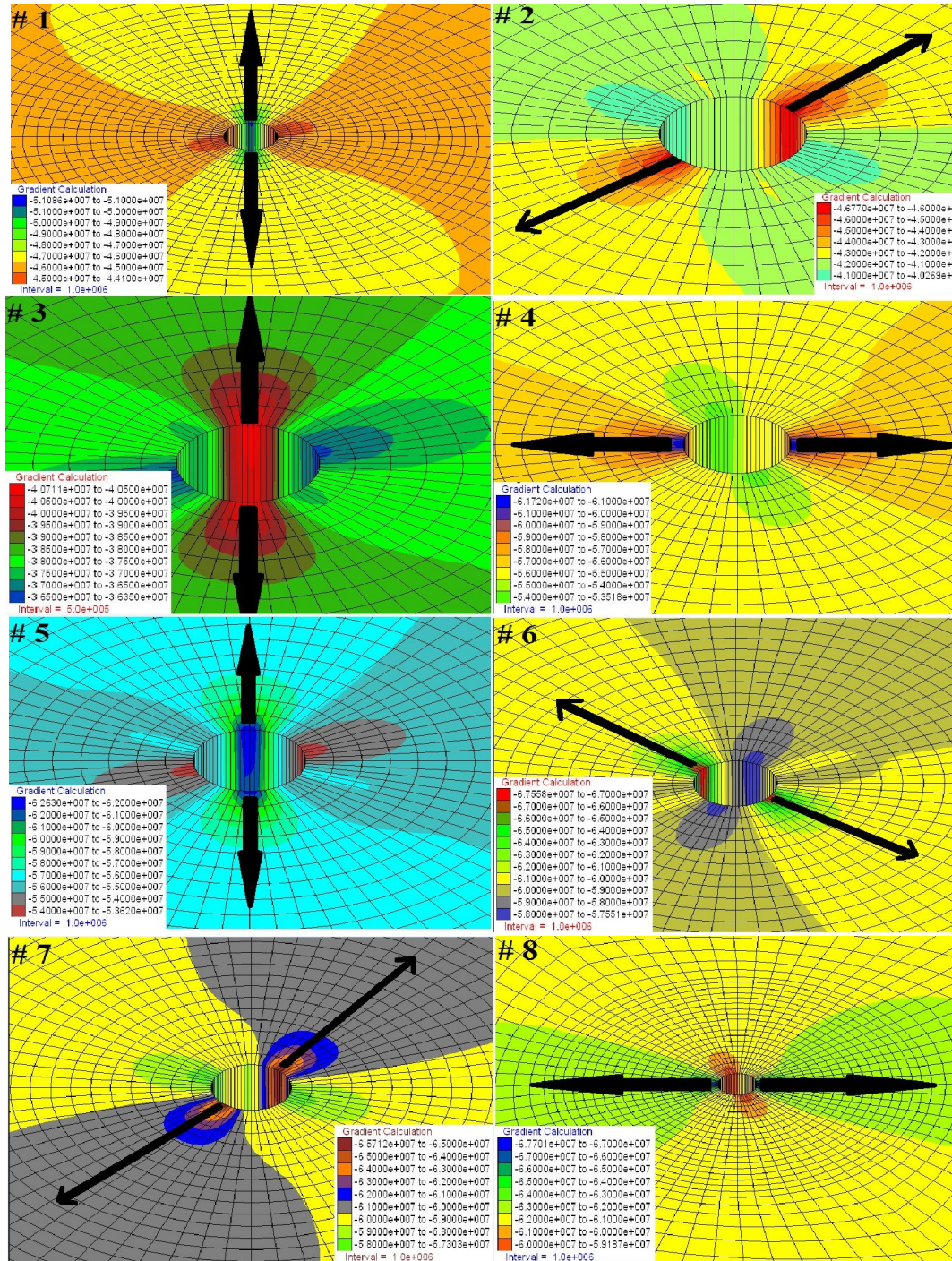

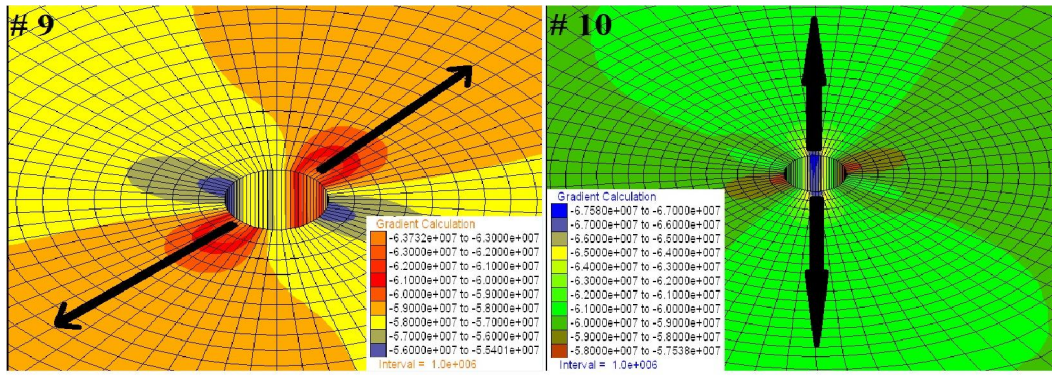
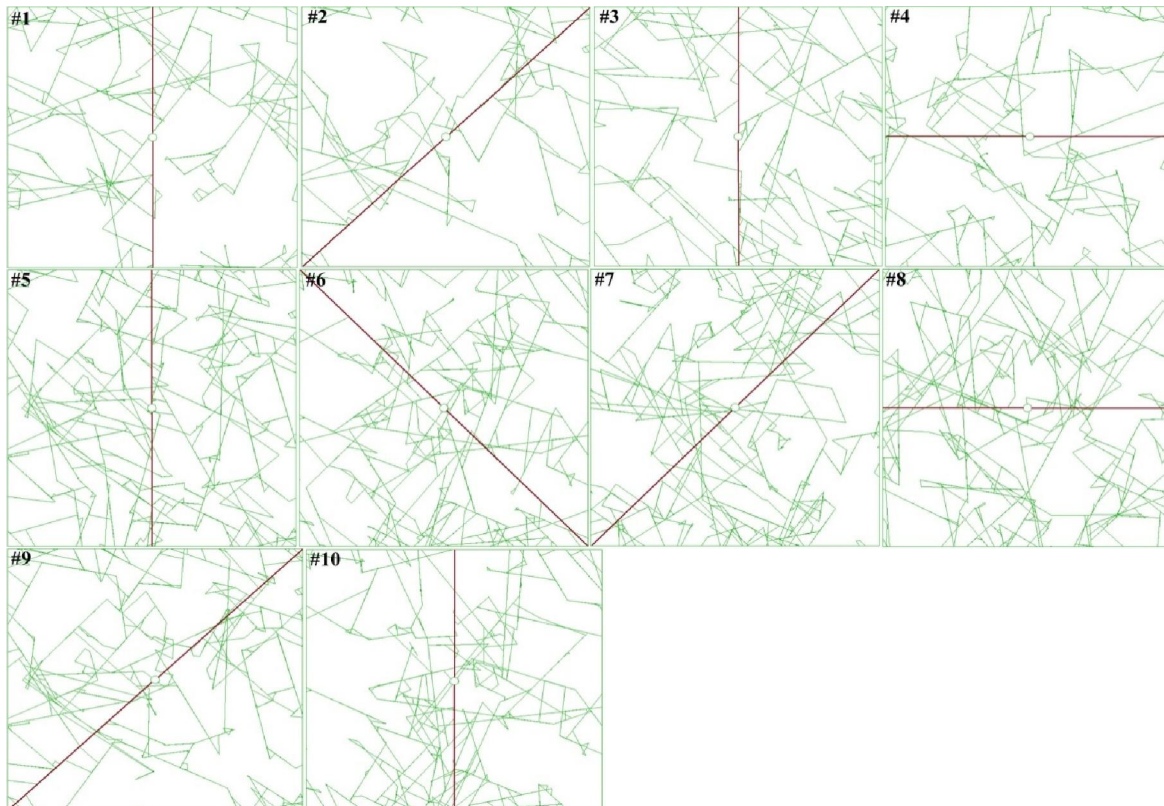

**Figure1.** Direction of forming the hydraulic fracture base on distribution of main stress around the wells

**Model description**

Block size for all wells in a block is 20 \* 20 m that the Well is located in the middle of the block. With data from cores and logs Status of natural fractures around the wells are simulated with a distinct element code. The main point is that in this simulation only fractures that are connected at least with a more natural fracture is shown. In other words, if a natural fracture is not connected to any other fracture, it is not shown. After determining the direction of the hydraulic fracture, hydraulic fracturing operation with different length and opening is done in each well. All 10 wells in the

study, fractures length of 2 meters started and in each stage, 2 meters long will be added to hydraulic fractures that block size is equal to the crack length reaches 20 meters. But height or aperture of hydraulic fracture in each well is almost a different choice. Schematic of the applied hydraulic fracture length of 20 meters in each well and Statuses of natural fracture around each hole can be seen in Figure 2. On the wall of well a group of nodes are defined to measure the flow of production. In this model it is assumed the flow source is only natural fracture of reservoir.



**Figure 2.** Natural fractures position around the wells and hydraulic fracture operation with 20 m long in wells

Analysis Results

Well #1, the hydraulic fracture is located in an area that high concentration of natural fracture are exist, but on other side we can see a few number of natural fractures. Since production is only from natural fractures that are connected to gather and finally connect to well, In this case the result is almost the most productive part of the fractures will be more connected to the wells that this matter can be seen in figure 3. In well #2, in some parts that near the well there is a small number of natural fractures but well away from the wall gradually becomes greater number of fractures. So, hydraulic fracture with low length and high height cannot increase the production. Better words, when the hydraulic fracture length is reduced in such an environment, the fracture created by adding height cannot affect, but when the length of hydraulic fracture will increase that reach to such an environment with high density, In this case add height can affect the production severely which is shown in figure 4. Hydraulic fracturing operation in well #3 will apply in direction that the distribution of natural fractures are same, and a few number of natural fractures disconnected by hydraulic fracture and connected to well. Production flow chart at well No. 3 when hydraulic fracture applied is given in Figure 5. As can be seen when the hydraulic fracture equal to 2, 4 and 6 meters, the production in different aperture is the same. If the area that these lengths of

hydraulic fractures are located there considered carefully, Can be seen that the hydraulic fracture is located in a region almost intact virgin and increased to 6 meters in length practically does not interrupt the natural fracture. With increasing length of hydraulic fracture more normal fracture will connect to well. If the chart is accurate, this conclusion can reached that the length can play an important role. And production shows more sensitivity to length and after opening approximately 200 micrometers, with increased production of this parameter is almost constant.

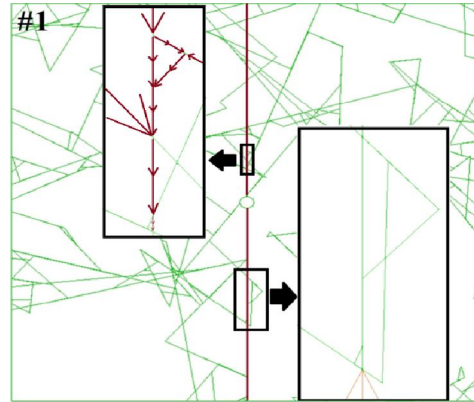

Figure 3. Current status between the natural fractures that connected to hydraulic fracture in the areas of reservoir in well #1

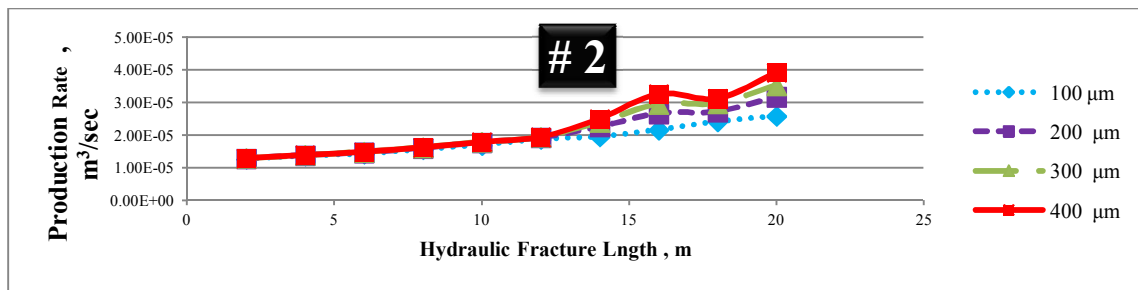

Figure4. Production flow rate in hydraulic fracture with different length and height in well #2

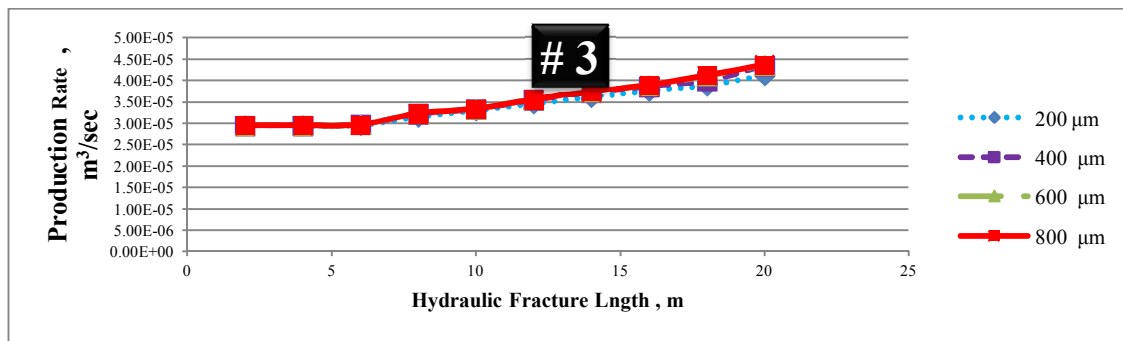

Figure5. Flow chart of production with different length and height of the hydraulic fracture in well #3

Well #4 is established in the same situation, that mean the direction of hydraulic

fracture in some area of reservoir will extended that a few number of natural fracture connected to that



reservoir, therefore the length should be increased and so that because of that with increasing of natural fracture then hydraulic fracture reach the best results.

In well #5 we have the different situation, because this well is located in reservoir with many natural fractures. In such a situation by increasing the

length of hydraulic fracture more natural fractures can connect to the well. Flow diagram of production of these wells (Figure 6) also shows this significant point that with increases of length and hydraulic fracture aperture production is also increase.

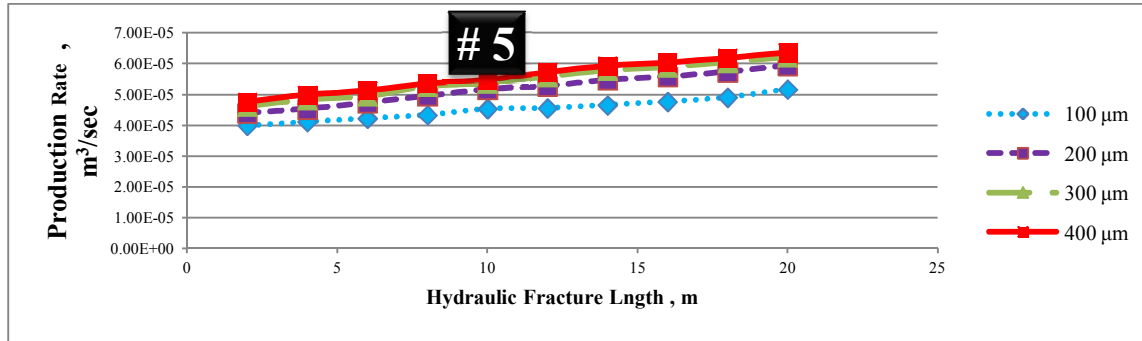

**Figure 6.** Flow diagram of production varies with the length and height of hydraulic fracture in wells #5

In well #6 the density of natural fractures near the wells are numerous and in more distant areas is less. Figure 7 shows the Flow chart of the production in well #6 with applies of hydraulic fracture. In the hydraulic fracture with length of 4 m, because of no natural fracture related to hydraulic fracture thus Production is equal to the length of 2 m. When hydraulic fractures in the reservoir is extended Reach up to 12 meters long, effectively increasing the height of the fracture so that should not impact on production levels and is often ineffective. Expected with increasing of length due to more relationship natural fracture and hydraulic fractures the production should increases and this increase will be more with adding more apertures, but this is not. Perhaps it could be justified so that the hydraulic fracture with length of 12 m that are near the wells connect to well and on other hand these fractures are related to each other, is only part of its fluid exchange to Hydraulic fracture and other parts exchange in their fractures and may be in communication with nearby wells increase the production by themselves not by hydraulic fracture. Figure 8 shows that this phenomenon better. When the hydraulic fracture length exceeds 12 meters again increasing of aperture shows its influence and will affect the production. This effect can probably find a connection to the natural fractures in intervals that are located far away from well with hydraulic fractures.

In well #7 we have the same condition. In this well when the hydraulic fracture of fractures related to the well passes, in other mean, reaching

over 12 meters long and when is connected to other natural fracture will have more effect on production. As can be seen in Figure 9, along with hydraulic fracture to 16, 18 and 20 meters and the aperture effect will be more. This is because the fracture in the non-connected and more wells are connected through a hydraulic fracture.

Wells 8 and 9 as wells 3 and 4 have similar condition however those more natural fractures are around this well and hydraulic fracture which expands in main direction makes more cuts. Thus both the length and the aperture can be effective in on this two production wells. In well no 8 when hydraulic fracture is near the well that full of natural fracture and also increase of height for fracture had no effect on production (figure10). But the point here is that it should be noted that when the hydraulic fracture is connected to high-density area (Higher than 12 meters in length) Add the fracture height, strongly enhances the production. In fact, because of relation between natural hydraulic fracture and natural fracture, adding height to the hydraulic fracture by high capacity of this natural fractures that are connected be compensated. Flow diagram of well no 9 express this fact that if the hydraulic fracture in order that expands, communicate with a large number of natural fractures, by Increase of hydraulic fracture length, height can be increased (Figure 11). When the gap length can be increased in such an environment, the increase in the production flow sensitivity is higher than the hydraulic fracture aperture.

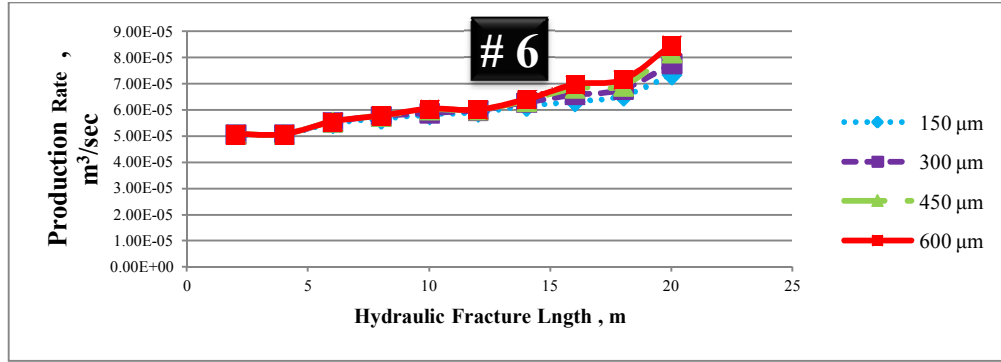

Figure7. Flow chart of production varies with the length and height of hydraulic fracture in well #6

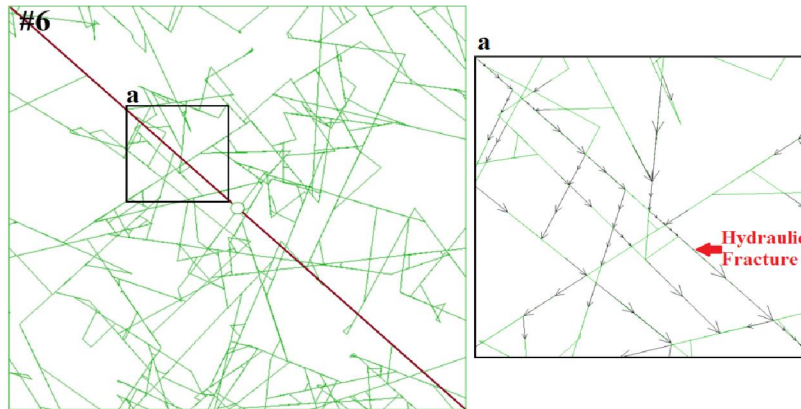

Figure 8. The status of flow between the natural fractures near the wells associated with hydraulic fractures in well #6

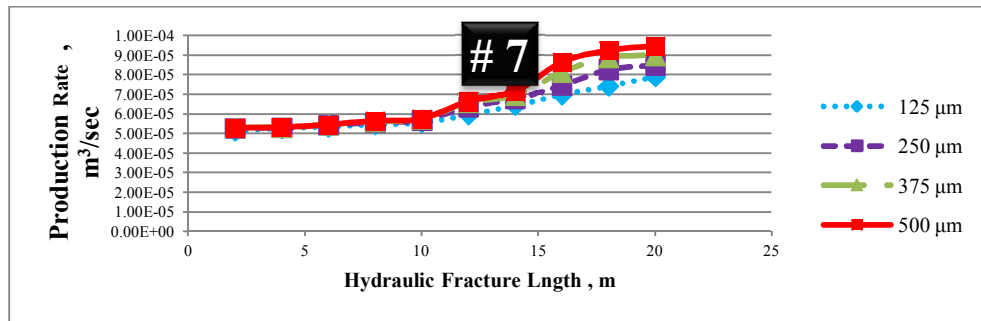

Figure9. Flow diagram of production varies with the length and height in hydraulic fracture of well #7

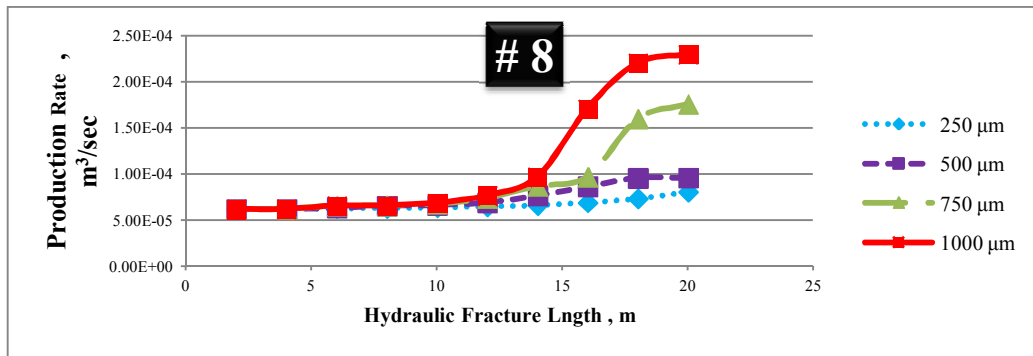

Figure10. Flow diagram of production varies with the length and height of hydraulic fracture in well #8

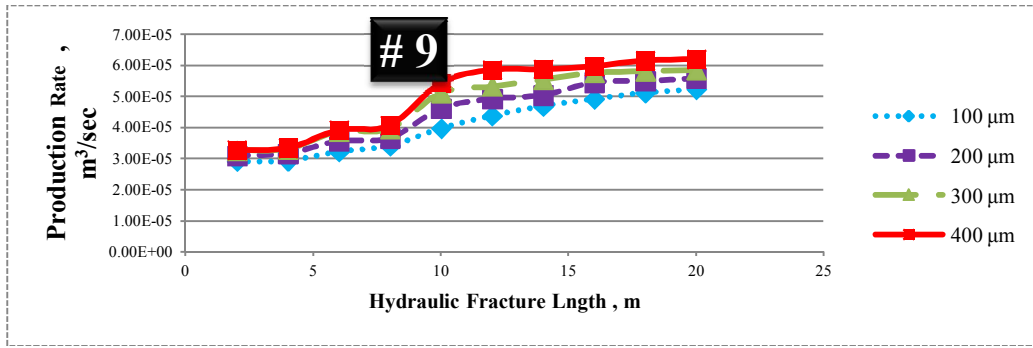

Figure11. Flow diagram of production varies with the length and height of hydraulic fracture in well #9

A hydraulic fracturing operation in the well #10 is such that the distribution of natural fractures in the both sides different. Flow diagram of the production of this well is given in Figure 12. When the hydraulic fracture connects to a large number of natural fractures that are far from the well, both length and aperture have effect on the production. During the 10-meter to the higher length, hydraulic fracture connection to the natural fractures become more production also increased due to increase of aperture and length. This phenomenon can be explained such that when a hydraulic fracture contact

to the area with a large accumulation of natural fracture that are far from the well, Due to lack of communication or poor communication this fractures with each other and also with the wells, their current capacity are exchange with hydraulic fracture and this causes the increased aperture is offset by the exchange of high flow (Figure 13). Maybe if the other hydraulic fracture, that natural fracture in the low-density area expands, the high concentration of natural fractures indicate more sensitivity of production rate.

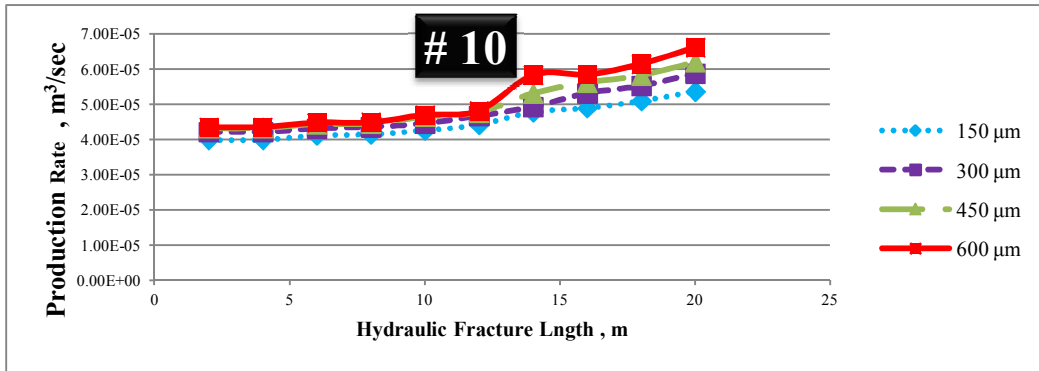

Figure12. Flow diagram of production varies with the length and height of hydraulic fracture in well #10

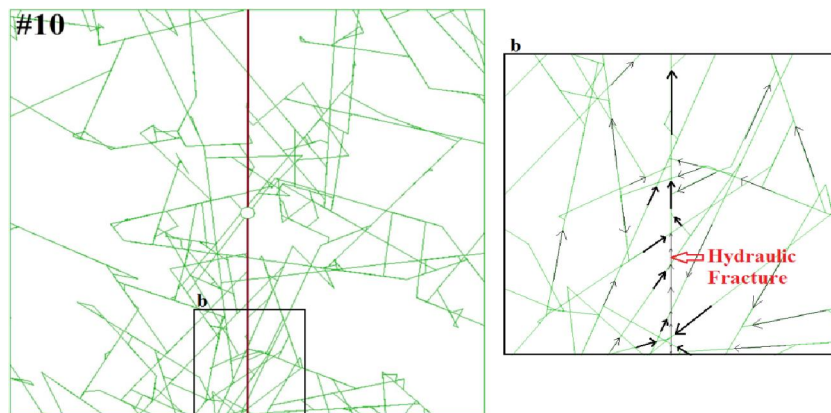
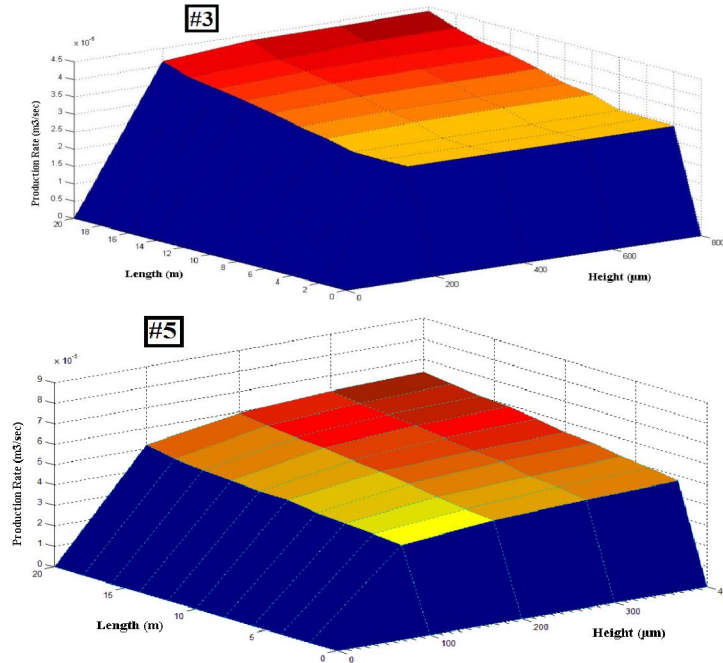

Figure13. Status of the natural fracture flow that far away the well with hydraulic fracture in well #10

If well #3 as well in orders that it hydraulic fracturing operation expands in that direction that lowest number of natural fractures are interrupted by hydraulic fractures I.e. the applied area hydraulic fracture with low density of natural fractures and Well #5 as well, with high density and nearly uniform in the hydraulic fracture is considered, so, sensitivity analysis can be performed in these two wells to check the length and height of hydraulic

fracture on production rate. By coding in matlab software diagram of the two wells is given in Figure 14. Clearly, in well #3 the number of fractures in hydraulic fractures path are low, and also the length play an important role and adding in aperture to the fracture has very little effect on production. In well #5 the height of hydraulic fracture has more effect on production. These results show qualitative agreement with field results (e.g. Z. Zaho et al., 2005).



**Figure14.** Effect of hydraulic fracture length and height on production flow in wells 3 and 5

### Conclusion

According to the performed analysis, obtained results can be summarized as the following:

- In fractured reservoirs, mainly if the hydraulic fracture expands in direction that more natural fractures will connect to well, in this case the efficiency will go up.
- In fractured reservoir with low natural fracture, the fracture must be applied with great length and by connecting greater number of natural fracture to well, the production will increase. And in this situation by adding to the height of hydraulic fracture practically will not be acceptable on production flow.
- In fractured reservoirs which have natural fracture with high density the hydraulic fracture must be apply with more conductivity in reservoir that it need more aperture in hydraulic fracture. In such a reservoir due to relation between natural fractures and conducted

fractures, we can see more influx to fracture. And adding to the height of hydraulic fracture the flow capacity of this hydraulic will rises. That with this increase of capacity due to high flow exchange of natural fractures can be compensated.

- If the areas around the well contain many natural fractures expansion of hydraulic fractures in such an area would not be very successful and also low increase of production is due to length and add height to the hydraulic fracture has no effect on production.
- The most efficient mode of operation of hydraulic fracturing occurs when the hydraulic fracture can connect the natural fracture to well that are far from well. If these numbers of natural fractures are high or other hydraulic fractures that are far from the well have a contact with high density area, so increase in aperture can have extreme effect on production.

**Reference**

1. Zhang, X. and Jeffrey, R.G. 2006. The role of friction and secondary on deflection and reinitiation of hydraulic fractures at orthogonal pre-existing fracture. *Geophysical Journal International*, 166 (3): 1454-1465.
2. Zhang, X. and Jeffrey, R.G. 2008. Reinitiation or termination of fluid-driven fractures at frictional bedding interfaces. *Journal of Geophysical Research*, 113 B08416. DOI: 10.1029/2007JB005327.
3. D. A. Chuprakov, A. V. Akulich, E. Siebrits, M. Thiercelin. 2010. Hydraulic Fracture Propagation in a Naturally Fractured Reservoir, SPE 128715, presented at the SPE Oil and Gas India Conference and Exhibition held in Mumbai, India, 20–22 January 2010.
4. Zhang, Z., and Ghassemi, A. 2011. Simulation of hydraulic fracture propagation near a natural fracture using virtual multidimensional internal bonds, *International Journal for Numerical and Analytical Methods in Geomechanics* 35(4):480-495.
5. Weng, X., Kresse, O., Cohen, C., Wu, R., and Gu, H. 2011. Modeling of Hydraulic Fracture Network Propagation in a Naturally Fractured Formation. Paper SPE 140253 presented at SPE hydraulic fracturing technology conference and exhibition. The Woodlands, Texas, USA, 24-26 January.
6. Z. Zhao, SPE, D. Liu, W. Liu, L. Chai, and H. Zhou. 2005. Development of Systematic Hydraulic Fracturing Technology for a Naturally Fractured Reservoir. SPE 94101, Presented at the SPE Europe/EAGE Annual Conference held in Madrid, Spain, 13-16 June 2005.

10/6/2012

**Assessment of relationship between Iron deficiency and preterm labor**

Nazli Navali

Assistant professor of Obstetrics & Gynecology, Women's Reproductive Health Research Center, Department of Obstetrics & Gynecology, Faculty of Medicine, Tabriz University of Medical Sciences, Tabriz, Iran.

[navalin@yahoo.com](mailto:navalin@yahoo.com)

**Abstract:** Preterm labor is important in a predication of neonatal mortality. In united state of America it's relieved that the mortality rate of neonates has direct relation with frequency of low birth weight neonates and preterm labor. Neonates mortality and sever morbidity or both, before 26<sup>th</sup> weeks of pregnancy occur in most of neonates and before 24<sup>th</sup> weeks of pregnancy occur approximately in all of them. It is prominent that prenatal care cost considered as national cost, for this reason frequent studied design to decrease this costs, neonatal mortality and preterm labor. The aim of this study is to determine the relation between iron deficiency anemia and preterm labor and Lab finding in iron deficiency anemia and preterm labor too. In this study, at 2005 year, 200 pregnant women in Tabriz Al-Zahra and Taleghani OB hospitals with cooperation of Al-Zahra laboratory undergo a cohort and case control study, all women base on delivery type divided into two groups, one 100 women with term delivery and other 100 women with preterm delivery. Assessment of serum iron, total iron binding capacity (TIBC), Ferritin, hemoglobin and hematocrit were done in all women before delivery. Within the main part of study, we determine the frequency of neonate's gender, weeks of pregnancy and age of mothers. In relation between delivery type (preterm or term) and serum iron, hemoglobin and hematocrit, we came out P\_Value equal to <0.001, 0.004 and <0.001, respectively that show pregnant women with preterm delivery have low serum iron, hemoglobin and hematocrit in comparison with women with term delivery, but in relation between serum ferritin and TIBC P\_Value was 0.987 and 0.930, respectively that had no statistical significance. In group with preterm labor, 62% of neonates were male and 38% was female. The major part of mother of this group is in third's decade of life. Respectively 31%, 19% and 50% of mother with preterm labor had borne her neonate in 26-30, 31-33 and 34-37 weeks. It seems that relation between iron deficiency anemia in pregnancy and delivery type is deniable. However, to show its relation more studies must be performed in this field.

[Nazli Navali. **Assessment of relationship between Iron deficiency and preterm labor.** *Life Sci J* 2012;9(4):1778-1781] (ISSN:1097-8135). <http://www.lifesciencesite.com>. 270

**Keywords:** Species richness; beta-diversity; taxonomic diversity; forest

**1. Introduction**

Preterm labor is a major cause of infant mortality and morbidity .Due to unknown causes and mechanisms of preterm labor the primary prevention is not always possible However some studies of has shown its association with the iron deficiency anemia(Scott, 2003).

Iron is an essential element for all cells. In the lack of iron the production of the hemoglobin in erythroid cells will be interfered thus the transfer of the oxygen to the cells decreases

Iron deficiency anemia is the most common cause of acquired anemia in pregnant women and it is seen in 15 to 25 percent of pregnancies .Iron deficiency is suspected when the mean corpuscular volume (MCV) of less than 80  $mg/m^2$ .

According to Barker et al (1995) Anemia may cause cardiovascular disease in adulthood (Barker, 1995) Kadyrov and colleagues (Kadyrov, 1998) have also provided evidence that maternal anemia can cause changes in the placental vascular structure with changes in the angiogenesis in early pregnancy.

Scanlon and colleague have studied hemoglobin levels of mothers of neonates with preterm labor or neonates with intra uterine growth restriction in 173031 pregnancies in 2000(Scanlon, 2000). the hemoglobin levels less than 2 standard deviation in 12<sup>th</sup> week of pregnancy was associated with 1.7 fold of increased preterm labor however the high hemoglobin levels (more than 3 standard deviation) in the 12 -18<sup>th</sup> weeks of was associated with preterm labor with 1.8 fold of increased preterm labor.

**2. Material and Methods**

In a cross sectional case control study in gynecology department of Tabriz University of medical sciences, we studied the role of iron deficiency anemia in preterm labor of pregnant women.

200 pregnant women divided into two groups randomly. Group 1 (term delivery, control group) and group 2(preterm delivery, case group)

Women with obstetric complications such as multiple pregnancy, polyhydramnios, placenta previa,

diabetes mellitus and preeclampsia were not initially enrolled in the study groups.

Before delivery, venous blood samples of 5 ml were collected from all patients and the following factors were studied: serum iron (SI), hemoglobin (Hg), hematocrit percent (Hct), total iron binding capacity (TIBC) and serum ferritin (SF).

Iron and TIBC kits was made in ZistShimi company, and the normal ranges for the Iron in pregnant women was 40 -155  $\mu\text{g/dl}$ , and the normal range for TIBC in the pregnant women was 220-450  $\mu\text{g/dl}$ .

For quantitative measurement of the serum ferritin we used immunoassay method with the Ferritin kits made by RADIM company, the normal ranges of ferritin was 17-390  $\text{ng/ml}$  for men, 10-90  $\text{ng/ml}$  for premenopausal women and 10-150  $\text{ng/ml}$  for menopause women.

All the collected data was analyzed with SPSS software version 13 .we used independent sample t-test for analyzing association between type of the delivery with the serum iron level, TIBC, serum ferritin and hematocrit, we also used chi square test for defining the neonate weight with maternal age and the delivery weeks . P value less than 0.05 was considered significant, and it was assumed highly significant less than 0.001.

### 3. Results

In a case control study we studied 200 pregnant women in the form of two groups, group 1 100 women with term delivery and group 2,100 women with preterm delivery.

The mean serum iron in all studied cases was  $287.59 \pm 308.19 \mu\text{g/dl}$  in the range of 22 -1361  $\mu\text{g/dl}$ . The mean serum iron in women with term pregnancy was  $407 \pm 386.30 \mu\text{g/dl}$  and in women with preterm pregnancy was  $168.18 \pm 113.52 \mu\text{g/dl}$  which was significantly higher in women with term pregnancy ( $P < 0.001$ ). This indicates that serum iron level in pregnant women is a risk factor for preterm delivery.

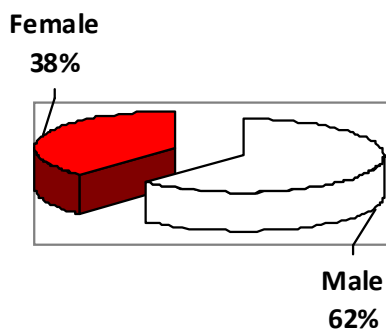

Chart 1. Gender of infants with preterm labor

The mean TIBC level for all studied cases was  $111.61 \pm 327.27 \text{ mg/dl}$ , the mean TIBC level in the term group was  $111.24 \pm 362.65 \text{ mg/dl}$  and the preterm delivery group was  $111.98 \pm 289.45 \text{ mg/dl}$ , there was not significant difference between two groups in TIBC levels ( $P = 0.987$ ).

The mean ferritin in the all studied cases was  $22.92 \pm 2.0008 \text{ ng/ml}$ . the mean ferritin levels was  $23.05 \pm 22.99 \text{ ng/ml}$  in the women with term delivery and  $22.8 \pm 16.6 \text{ ng/ml}$  in the preterm delivery group which was not significantly different ( $p = 0.930$ ) which indicates no relationship between Ferritin level and type of the delivery.

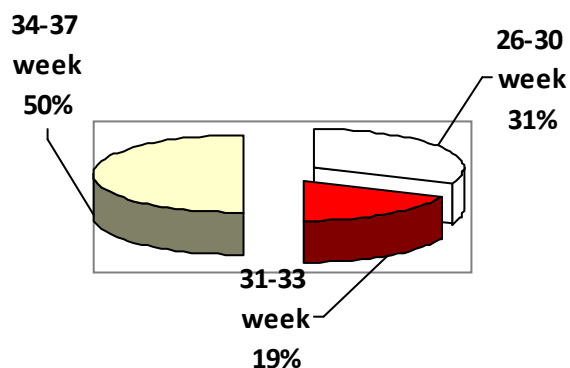

Chart 2. Frequency pregnancy age of patients with preterm labor

The mean hemoglobin level in all the women we studied was  $13.022 \pm 1.15 \text{ gr/dl}$ . The mean hemoglobin level in the group with term delivery was  $13.324 \pm 0.94 \text{ gr/dl}$  and in the group with preterm delivery was  $12.69 \pm 1.25 \text{ gr/dl}$ .

The mean hematocrit in all 200 cases was  $39.80 \pm 3.4$  percent and the hematocrit mean level in women with term delivery was  $40.5 \pm 2.94 \text{ gr/dl}$  and in the preterm delivery it was  $39.1 \pm 3.8 \text{ gr/dl}$  which was significantly higher in the term delivery group ( $p = 0.004$ ).

Gender of infants with preterm labor was shown in chart 1. Frequency pregnancy age of patients with preterm labor was shown in chart 2.

In this study, infant sex, birth weight, maternal age, birth week, was found only in patients with preterm labor. Average age of the mothers with preterm delivery was  $26.81 \pm 5.38$  years. The offspring of pregnant women with preterm labor 62 baby boys and 38 baby girls that male to female ratio (M / F) in women with premature labor was 1/6 respectively. Mean weight gain of preterm delivery,  $2054.1 \pm 619.66 \text{ gr}$  results suggest that the relationship between sex and birth weight of infants

was not significant ( $P=0.791$ ). Relationship between sex and gestational age was not significant ( $P=0.543$ ).

#### 4. Discussions

The present study is designed to the measurement of parameters of the iron deficiency anemia in preterm delivery and its aim was the answer to the question that is there a relationship between iron deficiency anemia and preterm labor?

Lieberman and colleague stated that in black women there is straight relationship between low hematocrit levels and the rate of preterm labor is also found that anemia is an indicator of nutritional deficiencies Anemia may be associated with fetal growth restriction (Lieberman, 1987). In our study there was a significant relation between the hematocrit level and the type of the delivery

Klebanoff and colleagues examined the association between hematocrit and risk of preterm delivery, stated that the Incidence of preterm delivery in women was almost twice (adjusted odds ratio=1.9) (Klebanoff, 1991).

In the study of Lu et al, it has been stated that in the first half of the pregnancy hematocrit (less than 37%) is associated with the high incidence of the preterm labor in a weekly manner(Lu, 1991).

The results of this study differ from the results of our study in the hematocrit level. in our study women with preterm labor had a low levels of hematocrit that can be due to the low population of our study and also this can be as a result that in our study only 3 women with preterm labor had high levels of hematocrit and in the term delivery group 2 women had a high levels of the hematocrit.

In the study of Murphy and colleague in Wales it has been stated that low levels of hemoglobin is associated with higher risk of the preterm labor (Murphy, 1986).

In our study the women was not controlled exactly from the beginning of the pregnancy and blood sampling was done before the delivery. So we can not evaluate the association of anemia and hemoglobin levels and the type of the delivery and we can just state that women with preterm labor only have Low levels of hemoglobin and hematocrit.

Scholl and colleague have studied that women with iron deficiency anemia is at the risk of preterm labor two times more than other normal women(odds ratio=2.66)while there was not a relationship between other causes of the anemia(Scholl, 1992).

In our study all the factors associated with the iron deficiency anemia, especially serum ferritin levels are studied. But the women were not categorized upon the anemia, and they were divided into two groups upon their type of the delivery. As a result women with preterm labor had low levels of

the hemoglobin and hematocrit, but the data was not meaningful about the serum ferritin and there was not a significant relationship.

The ferritin levels were so similar in two groups of the delivery and there was not a significant relationship between ferritin levels and the type of the delivery.

In a study by the Anupam Goel and his colleague, its is stated that in women with preterm labor there was a low level of the serum Iron while the difference between the two groups was not significant in their ferritin levels(Goel, 2003).

In our study similar the above study the serum iron levels was lower in the women with preterm labor and there was not significant difference in the ferritin levels in two groups.

In a study that was done in the USA in 2000, it is stated that the risk of birth of a preterm neonate in women with low hemoglobin is increased in first and second trimester. These data consider the significance of anemia and High levels of hemoglobin as an indicator for adverse pregnancy outcome (Lieberman, 1987).

In our study, the mean hemoglobin level for women with term delivery was 13.23 while this parameter was 12.69 for women with preterm labor and was significantly lower for these women (preterm labor).

Scholl & Hediger and colleagues stated that there is no relationship between the iron deficiency anemia and the preterm labor in this time (Scholl, 2005).

Zhou and colleague examined the contributing factors in the preterm labor and stated that there is a U shape relationship with the hemoglobin of mothers in the early pregnancy and the risk of the preterm labor, and when the hemoglobin level is considered in the 5 to 8 months of the pregnancy and proper treatment plans is made, the risk of the preterm labor is reduced significantly (Scholl, 1994).

Klebanoff and colleague with examining the 35000 pregnant women have stated that there is a relationship between the low hemoglobin levels in early pregnancy and high hemoglobin level in late pregnancy and the risk of the preterm labor (Garn, 1981).

The findings of this study was different from our study in the results of the last trimester of the pregnancy which stated that low hemoglobin levels was associated with preterm labor even in presence of high hematocrit levels.

The results of the study conducted by Singh and colleague reveals that the prevalence of the preterm labor is higher in women with anemia in comparison without anemia. This study also states that there is not significant difference in other neonatal complications between two groups (Singh, 1998).



The results of this study were matched with the results of our study and the time of measuring the parameters indicating the anemia was similar in two studies.

### Conclusion

In the mothers with preterm labor the serum iron levels was lower in comparison with mothers with term labor, hemoglobin and hematocrit levels was also lower in women with preterm labor.

Serum TIBC and Ferritin levels was not different in women with preterm labor and women with term delivery indicating that these factors has no effect on the result of delivery.

### Corresponding Author:

Dr. Nazli Navali

Women's Reproductive Health Research Center, Department of Obstetrics & Gynecology, Faculty of Medicine, Tabriz University of Medical Sciences, Tabriz, Iran.

E-mail: [navalin@yahoo.com](mailto:navalin@yahoo.com)

### References

- 1-Scott JR, Gibbs RS, Karlan BY, Haney AF. Danforths Obstetrics and Gynecology. Lippincott Williams and Wilkins, Philadelphia, 2003; 410-35.
- 2-Barker DJ, Osmond C, Golding J, Kuh D, Wadsworth ME. Growth in utero, blood pressure in childhood and adult life, and mortality from cardiovascular disease. *BMJ* 1989;298(6673):564-7.
- 3-Kadyrov M, Kosanke G, Kingdom J, Kaufmann P. Increased fetoplacental angiogenesis during first trimester in anaemic women. *Lancet* 1998;352(9142):1747-9.
- 4-Scanlon KS, Yip R, Schieve LA, Cogswell ME. High and low hemoglobin levels during pregnancy: differential risks for preterm birth and small for gestational age. *Obstet Gynecol* 2000;96(5 Pt 1):741-8.
- 5-Lieberman E, Ryan KJ, Monson RR, Schoenbaum SC. Risk factors accounting for racial differences in the rate of premature birth. *N Engl J Med* 1987;317(12):743-8.
- 6-Klebanoff MA, Shiono PH, Selby JV, Trachtenberg AI, Graubard BI. Anemia and spontaneous preterm birth. *Am J Obstet Gynecol* 1991;164(1 Pt 1):59-63.
- 7-Lu ZM, Goldenberg RL, Cliver SP, Cutter G, Blankson M. The relationship between maternal hematocrit and pregnancy outcome. *Obstet Gynecol* 1991;77(2):190-4.
- 8-Murphy JF, O'Riordan J, Newcombe RG, Coles EC, Pearson JF. Relation of haemoglobin levels

in first and second trimesters to outcome of pregnancy. *Lancet* 1986;1(8488):992-5.

- 9-Scholl TO, Hediger ML, Fischer RL, Shearer JW. Anemia vs iron deficiency: increased risk of preterm delivery in a prospective study. *Am J Clin Nutr* 1992;55(5):985-8.
- 10-Goel A, Jain V, Gupta I, Varma N. Serial serum ferritin estimation in pregnant women at risk of preterm labor. *Acta Obstet Gynecol Scand* 2003;82(2):129-32.
- 11-Scholl TO. Iron status during pregnancy: setting the stage for mother and infant. *Am J Clin Nutr* 2005;81(5):1218S-1222S.
- 12-Scholl TO, Hediger ML. Anemia and iron-deficiency anemia: compilation of data on pregnancy outcome. *Am J Clin Nutr* 1994;59(2 Suppl):492S-500S discussion 500S-501S.
- 13-Garn SM, Ridella SA, Petzold AS, Falkner F. Maternal hematologic levels and pregnancy outcomes. *Semin Perinatol* 1981;5(2):155-62.
- 14-Singh K, Fong YF, Arulkumaran S. Anaemia in pregnancy- a cross-sectional study in Singapore. *Eur J Clin Nutr* 1998;52(1):65-70.

9/29/2012

## A simple model to compute the blood flows through obstructed blood vessels

Mohsen Gh Kharaji<sup>1</sup>, Fakhroddin Dadjoo<sup>2</sup>, Y Alirezaei<sup>3</sup>, Ali Falavand<sup>4</sup>, Ameneh Langari\*<sup>5</sup>

<sup>1</sup>Shahrekord University of Medical Sciences, Shahrekord, Iran

<sup>2</sup>Civil Engineering Group, Chalooos Branch, Islamic Azad University, Chalooos, Iran

<sup>3</sup>Engineering Group, Cirjan Branch, Islamic Azad University, Cirjan, Iran

<sup>4</sup>Engineering Group, Ahvaz Branch, Islamic Azad University, Ahvaz, Iran

<sup>5</sup>North Khorasan University of Medical Sciences, Bojnurd, Iran

Corresponding author email: [amenehlangari@yahoo.com](mailto:amenehlangari@yahoo.com)

**Abstract:** The aim of this article is to measuring the blood flow, when they pass through obstructed blood vessels. In many medical arteries the amount of the blood flow inside canals and obstructed vessel is important and reduces due to the arteries. However, the problem with measurements in such circumstances lies in the lack of precise and appropriate experimental data needed for the calculation of the blood passes through the vessel. To overcome the shortcoming, hence, the effect of the most common type orifices, i.e., Square edge Orifice ( $D$  &  $D/2$  taps), were put to the test, by simulating the flow with the use of CFD methods and Fluent 6.0 software, for  $0.25 \leq \beta \leq 0.5$  and  $10,000 \leq Re_D \leq 200,000$ , fixed temperature of  $300^K$ . Therefore, relations were obtained for blood as the incompressible fluid.

[Kharaji M. Gh., Dadjoo F., Alirezaei Y., Falavand A., Langari A. **A simple model to compute the blood flows through obstructed blood vessels.** *Life Sci J* 2012;9(4):1782-1788] (ISSN:1097-8135). <http://www.lifesciencesite.com>. 271

**Keywords:** Blood flow, Orifice, Vessel, Fluent, Computational fluid dynamic (CFD)

### 1. Introduction

Disruption of normal blood flow to the heart, lung, and brain due to thrombosis is one of the leading causes of death and long-term adult disability in the developing world. Today, patients with pulmonary embolism, strokes, heart attacks and other types of acute thrombosis leading to near-complete vascular occlusion are most frequently treated in an acute care hospital setting using systemic dosages of powerful clot-dissolving drugs [1].

The obstructed part of the vessel can be simulated through an orifice. Orifice can be simulated as a plate with a hole in the middle which is vertical to the fluid. When the fluid reaches the orifice with a constant velocity and pressure, it has to be contracted in order to pass through the orifice hole. The maximum point of this contraction is called the “*Vena Contracta (VC)*” point which is actually placed after the orifice.

The pressure and velocity of the blood flow will change, while passing through the V.C. point and after that the fluid will once again expand and the pressure and velocity will again change.

By calculating the differences in pressure and velocity, we can calculate the flow of fluid with the help of Bernoulli equation. The sizing error factor is assigned by the ANSA/API 2530 standard.

The contraction form which happens after the orifice will make the results of the calculations using the Bernoulli equation, different to the ones determined by experiments; therefore a correction

factor must be determined in order to lower the error. This factor is called the “*discharge coefficient*” factor, and is usually calculated experimentally for different orifices with different  $\beta$  ratios.

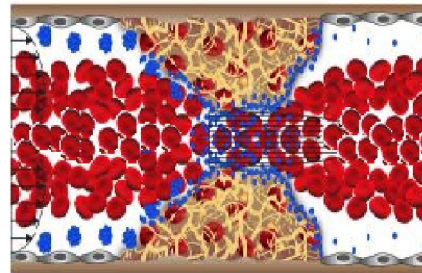

Figure 1. Blood flow through a obstructed vessel.

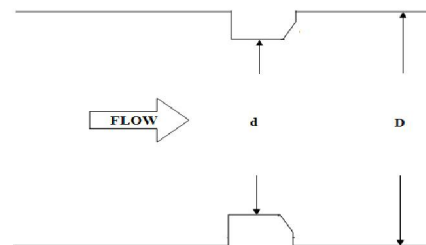

Figure 2. Square edge concentric orifice, with sizing parameters

The results of these calculations are available in reference books as charts, but it is not general and only available for particular conditions.

The biggest problem is that these experiments have been widely done for compressible and incompressible fluids, and there is not much data available for two phase fluids and this lack of information has caused many problems.

Therefore, the aim of this project is to determine a new formula which can predict the discharge coefficient for the incompressible fluids at the  $\beta$  ratios between 0.25 and 0.5, with a standard error of 4-5 percent. After that some relations will be given for compressible and also two phase fluids which are widely used in the oil and gas industries. We hope to decrease the lack of information in this part and help them.

## 2. Theoretical basis

To control industrial processes, it is essential to know the amount of material entering and leaving the process. A few types of flow meters measure the mass flow rate directly, but the majority measures the volumetric flow rate or the average fluid velocity, from which the volumetric flow rate can be calculated. Most meters operate on all the fluid in the pipe or channel and are known as *full-bore meters*. Others, called *insertion meters*, measure the flow rate, or more commonly the fluid velocity, at one point only. The total flow rate, however, can often be inferred with considerable accuracy from this single-point measurement.

The most common types of full-bore meters are Venturi and Orifice meters.

A Venturi meter is a short conical inlet section leads to a throat section, then to a long discharge cone. Although Venturi meters can be applied to the measurement of gas flow rates, they are most commonly used with liquids, especially large flows of liquids where, because of the large pressure recovery, a Venturi requires less power than other types of meters.

The Venturi meter has certain practical disadvantages for ordinary plant practice. It is expensive, it occupies considerable space, and its ratio of throat diameter to pipe diameter can not be changed. For a given meter and definite manometer system, the maximum measurable flow rate is fixed, so if the flow range is changed, the throat diameter may be too large to give an accurate reading or too small to accommodate the next maximum flow rate. The orifice meter meets these objections to the Venturi but at the price of large power consumption.

In 2-in (50 mm) and larger line sizes the concentric orifice (Figure 2) is the most common restriction for clean liquids, gases, and low-velocity vapor (steam) flows. It is a sharp, square-edge hole bored in a flat, thin plate. The ratio of opening diameter  $d$  to pipe diameter  $D$  defines the  $\beta$  ratio. For

most applications this ratio should be between 0.2 and 0.75, depending on desired differential; a high  $\beta$  orifice produces less differential for the same flow rate than a small  $\beta$  orifice.

Depending on upstream and downstream tap locations, the flow meter is referred to as a corner tap, a flange tap, a D-and-D/2 tap, a pipe tap (2.5 D and 8D), or a vena contracta tap orifice flow meter. Vena contracta taps have been replaced by D-and-D/2 taps because future changes in orifice bore require no tap relocation.

Several standards [2,3] have been written to detail installation requirements and construction and to estimate the overall uncertainty (accuracy) [3].

The maximum pipe Reynolds number may be as high as  $3.3 \times 10^7$ . However, a discharge coefficient rise of up to 1.56 percent for a 0.71  $\beta$  ratio orifice has been reported by Jones at bore Reynolds number greater than  $8 \times 10^6$ . This rise, may be explained by the work of Grose on the inviscid (zero viscosity) contraction coefficient change with  $\beta$  ratio.

The basic equation for an orifice meter is obtained by writing the Euler equation for incompressible fluids across the upstream [4]:

$$\rho \left( \frac{\partial u}{\partial t} + u \frac{\partial u}{\partial x} + v \frac{\partial u}{\partial y} + w \frac{\partial u}{\partial z} \right) = -\frac{\partial p}{\partial x} + \rho g_x \quad (1)$$

$$v, w = 0$$

$$\rho u \left( \frac{\partial u}{\partial t} + u \frac{\partial u}{\partial x} \right) = -u \frac{\partial p}{\partial x} + \rho u g_x \quad (2)$$

Or

$$\rho \left[ \frac{\partial(u^2/2)}{\partial t} + u \frac{\partial(u^2/2)}{\partial x} \right] = -u \frac{\partial p}{\partial x} + \rho u g_x \quad (3)$$

Since flow is steady, the left-hand term in equation (1) vanishes. There is no variation in fluid velocity across the cross section, so the flow is unidirectional and the velocity  $u$  is a function only of  $x$  and since gravity acts in the negative  $x$  direction,  $g_x = -g$ . The partial differentials become total differentials. Hence, from equation (1),

$$u \frac{d(\rho u^2/2)}{dx} + u \frac{dp}{dx} + \rho u g = 0 \quad (4)$$

Thus for steady flow it is possible to divide through by the velocity  $u$ . by doing this and also dividing through by  $\rho$  equation (2) becomes:

$$\frac{d(u^2/2)}{dx} + \frac{1}{\rho} \frac{dp}{dx} + g \frac{dZ}{dx} = 0 \quad (5)$$

In a straight horizontal tube, in consequences, there is *no* pressure drop in steady constant-velocity potential flow. Integrating equation (3) will give:

$$\frac{P_a}{\rho} + gZ_a + \frac{u_a^2}{2} = \frac{P_b}{\rho} + gZ_b + \frac{u_b^2}{2} \quad (6)$$

Equation (4) is known as the Bernoulli equation without friction.

Most fluid flow problems encountered in engineering involve streams that are influenced by solid boundaries and therefore contain boundary layers. This is especially true in the flow of fluids through pipes and other equipments, where the entire stream may be in boundary layer flow.

To extend the Bernoulli equation to cover practical situations, two modifications are needed. The first, usually of minor importance, is a correction of the kinetic energy term for the variation of local velocity  $u$  with position in the boundary layer; the second, of major importance, is the correction of equation for the existence of fluid friction, which appears when ever a boundary layer forms.

The term  $u^2/2$  in equation (4) is the kinetic energy of a unit mass of fluid all of which is flowing at the same velocity  $u$ . when the velocity varies across the stream cross section, the kinetic energy is found in the following manner. Consider an element of cross-sectional area  $dS$ . The mass flow rate through this is  $\rho u dS$ . Each and the energy flow rate through area  $dS$  carries kinetic energy in amount  $u^2/2$ , and the energy flow rate through area  $dS$  is therefore:

$$d \dot{E}_k = (\rho u dS) \frac{u^2}{2} = \frac{\rho u^3 dS}{2} \quad (7)$$

Where  $\dot{E}_k$  represents the time rate of flow of kinetic energy. The total rate of flow of kinetic energy through the entire cross section  $S$  is, assuming constant density within the area  $S$ ,

$$\dot{E}_k = \frac{\rho}{2} \int_S u^3 dS \quad (8)$$

Then

$$\frac{\dot{E}_k}{\dot{m}} = \frac{\frac{1}{2} \int_S u^3 dS}{\int_S u dS} = \frac{\frac{1}{2} \int_S u^3 dS}{\bar{V} S} \quad (9)$$

### 2.1 Kinetic energy correction factor

It is convenient to eliminate the integral of equation (5) by a factor operating on  $\frac{\bar{V}^2}{2}$  to give the correct value of the kinetic energy. This factor, called the kinetic energy correction factor, is denoted by  $\alpha$  and is defined by

$$\frac{\alpha \bar{V}^2}{2} = \frac{\dot{E}_k}{\dot{m}} = \frac{\int_S u^3 dS}{2 \bar{V} S} \quad (10)$$

$$\alpha = \frac{\int_S u^3 dS}{\bar{V}^3 S}$$

### 2.2 Correction of Bernoulli equation for fluid friction

Friction manifests itself by the disappearance of mechanical energy. In frictional flow the quantity

$$\frac{p}{\rho} + \frac{u^2}{2} + gZ \quad (11)$$

is not constant along streamline, as called for by equation (4), but always decreases in the direction of flow.

For incompressible fluids, the Bernoulli equation is corrected for friction by adding a term to the right-hand side of equation (4). Thus, after introducing the kinetic energy correction factor, equation (4) becomes

$$\frac{P_a}{\rho} + gZ_a + \frac{\alpha_a \bar{V}_a^2}{2} = \frac{P_b}{\rho} + gZ_b + \frac{\alpha_b \bar{V}_b^2}{2} + h_f \quad (12)$$

If  $\bar{V}_a$  and  $\bar{V}_b$  are the average upstream and downstream velocities, respectively, and  $\rho$  is the density of the fluid, equation (7) becomes

$$\alpha_b \bar{V}_b^2 - \alpha_a \bar{V}_a^2 = \frac{2(p_a - p_b)}{\rho} \quad (13)$$

$$\bar{V}_a = \left( \frac{D_b}{D_a} \right)^2 \bar{V}_b = \beta^2 \bar{V}_b \quad (14)$$

If  $\bar{V}_a$  is eliminated from equations (8) and (9), the result is

$$\bar{V}_b = \frac{1}{\sqrt{\alpha_b - \beta^4 \alpha_a}} \sqrt{\frac{2(p_a - p_b)}{\rho}} \quad (15)$$

Equation (10) applies strictly to the frictionless flow of noncompressible fluids. To calculate the mass flow rate

$$Q = \rho \bar{V} A \quad (16)$$

Therefore

$$Q = \frac{\pi}{4} \frac{D_a^2}{\sqrt{\alpha_b - \beta^4 \alpha_a}} \sqrt{\frac{2(p_a - p_b)}{\rho}} \quad (17)$$

### 2.3 Correction to the theoretical equation:

The theoretical flow equation calculates the true flow rate only when all the assumptions used to

develop it are valid. This is seldom the case, and the true flow rate is almost always less than the theoretically calculated value.

How closely the true flow rate can be calculated depends almost entirely on the geometry of the contraction. For a venturi or flow nozzle, where the area reduction is gradual the agreement is within 1 to 3 percent. But for the square-edge orifice the abrupt area reduction places the minimum flow area downstream of the plate at the plane of the vena contracta. Since the diameter of the vena contracts ( $D_{VC}$ ) for an orifice cannot be measured, the theoretical equation includes the measured bore as the correlation diameter. Also, increased downstream turbulence results in an energy loss that is not accounted for by either Bernoulli's equation or the thermodynamic steady flow energy equation. These two factors result in the true flow being approximately 60 percent of the theoretically calculated value. The location of the two measuring taps is also important because it establishes the measured differential.

The theoretical equation is adjusted for these effects with two empirically determined corrections. The first is the *discharge coefficient*  $C$ , which corrects for velocity profile (Reynolds number), tap location, and contraction geometry; the second is an empirically derived *net expansion-factor equation* for orifice flow meters.

## 2.4 Discharge Coefficient

For a given primary element, the discharge coefficient is derived from laboratory data by rotating the true and theoretical flow rates. The true flow rate is determined by weighing or volumetric collection of the fluid over a measured time interval, and the theoretical flow rate is calculated with equation (11). The discharge coefficient is then defined as

$$C = \frac{\text{true flow rate}}{\text{theoretical flow rate}} \quad (18)$$

The discharge coefficient corrects the theoretical equation for the influences of velocity profile (Reynolds number), the assumption of no energy loss between taps, and pressure-tap location.

In some flow equations, the discharge coefficient is combined with velocity of approach and redefined as the *flow coefficient*. For fixed geometry primary devices, to simplify the equation, or where primary elements are available in a limited range of sizes, the flow coefficient is used in place of the discharge coefficient. The flow coefficient is defined as

$$K = \frac{C}{\sqrt{1-\beta^4}} = EC \quad (19)$$

Where  $E$  is the velocity of approach factor [5].

## 2.5 Method of Presenting the Discharge Coefficient

For all standardized primary elements, numerous test points have been used to develop an empirical equation that predicts the discharge coefficient from bore and pipe diameter measurements. The accuracy of these equations is usually acceptable, and a flow calibration is seldom performed. However, for Reynolds number, pipe size, etc., outside the specified range of the equation, a signature curve should be used to obtain the discharge coefficient.

In the turbulent flow regime ( $Re_D > 4000$ ), the discharge coefficient for all primary elements can be expressed with an equation of the general form

$$C = C_\infty + \frac{b}{Re_D^n} \quad (20)$$

In which  $C_\infty$  is the discharge coefficient at an infinite Reynolds number, and  $b$  is the Reynolds number correction term.

Depending on the primary element, the infinite Reynolds number discharge coefficient may be a constant or a function of measured dimensions or tap location. The value of  $b$  may also be a function of dimensions, or it may be 0. The Reynolds number exponent  $n$  is constant and depending on the primary element.

Therefore by taking in account the discharge coefficient factor, the equation (10) can be written as

$$u_0 = \frac{C_0}{\sqrt{1-\beta^4}} \sqrt{\frac{2(p_a - p_b)}{\rho}} \quad (21)$$

The small effects of kinetic energy factors  $\alpha_a, \alpha_b$  are also taken into account in the definition  $C_0$ .

## 3. Simulation and numerical method

Computational Fluid Dynamics (CFD) is one of the branches of fluid mechanics that uses numerical methods and algorithms to solve and analyze problems that involve fluid flows.

The fundamental basis of any CFD problem is the Navier-Stokes equations, which define any single phase fluid flow. These equations can be simplified by removing terms describing viscosity to yield the Euler equations. Further simplification, by removing terms describing vorticity yields the Full Potential equations. Finally, these equations can be linearized to yield the Linearized Potential equations.

The most fundamental consideration in CFD is how one treats a continuous fluid in a discretized fashion on a computer. One method is to discretize

the spatial domain into small cells to form a volume mesh or grid, and then apply a suitable algorithm to solve the equations of motion (Euler equations for inviscid and Navier-Stokes equations for viscous flow). In addition, such a mesh can be either irregular (for instance consisting of triangles in 2D, or pyramidal solids in 3D) or regular.

In all of these approaches the same basic procedure is followed:

1. The geometry (physical bounds) of the problem is defined.
2. The volume occupied by the fluid is divided into discrete cells (the mesh).
3. The physical modeling is defined - for example, the equations of motions + enthalpy + species conservation.
4. Boundary conditions are defined. This involves specifying the fluid behavior and properties at the boundaries of the problem. For transient problems, the initial conditions are also defined.
5. The equations are solved iteratively as a steady-state or transient.
6. Analysis and visualization of the resulting solution.

The model development and simulation were based on commercial CFD software, Fluent 6.0, and meshing software Gambit 2.0.

The software code is based on the finite volume method on a collocated grid.

Finite volume method is the "classical" or standard approach used most often in commercial software and research codes. The governing equations are solved on discrete control volumes. This integral approach yields a method that is inherently conservative (i.e., quantities such as density remain physically meaningful):

$$\frac{\partial}{\partial t} \iiint Q dV + \iint F dA = 0 \quad (22)$$

Where  $Q$  is the vector of conserved variables,  $F$  is the vector of fluxes (Euler equations or Navier-Stokes equations),  $V$  is the cell volume, and  $A$  is the cell surface area [6].

The Fluent 6.0, which is a finite volume code, was used in velocity, pressure and vena contraction computations while Gambit 2.0 provided complete mesh flexibility in solving flow problems with both structured and unstructured meshes in this study. All functions required to compute a solution and display the result in Fluent software are accessible either through an interactive interface or by constructing user-defined-functions (UDS).

The use of CFD simulation usually includes three steps: preprocessing, processing and post processing. In the preprocessing step, a specific system is identified. The geometry and material

properties should be clearly defined. Meshing usually follows after geometry is determined. This is accomplished by dividing geometry into many small elements or volumes. Meshing is complicated work, as it is critical for both the accuracy of final result and the cost of numerical calculation. The setting of boundary conditions, initial conditions and convergence criteria are also completed in preprocessing stage.

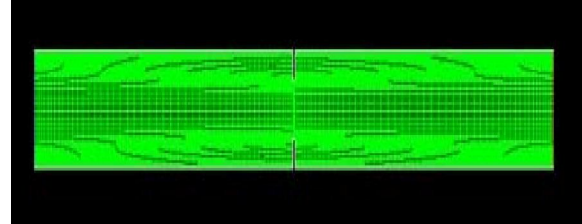

Figure 3. Overall pipe mesh

In the processing stage, the iterative calculations in each cell are carried out until convergence criteria are met. This calculation intensive process constitutes the core content of CFD application. After the completion of processing, the result can be evaluated either numerically or graphically. The graphical methods provide a more convenient way to evaluate the overall effect. This includes vector plot, contour plot, plot of scalar variables, etc. these visualization tools in post processing stage allows quick assessment and comparison of calculation results.

The studied orifice plate is shown in figure 2. The meshing work for the geometry of orifice plate and pipe was done with Gambit® 2.0. Altogether 6358 nodes representing 6298 cells and 12655 faces were used for meshing. Grid refinement was performed according to the concentration gradient within the module geometry.

For both single phase and two phase flow simulation, the flow is assumed to be turbulent and the  $k-\varepsilon$  turbulence model is employed. For two-phase model the mixture

Model is used, which is simplified multiphase model and can be used to model inhomogeneous multiphase flows where the phases move at different velocities or homogeneous multiphase flows with phases moving at same velocity. In the multiphase fluid, the fluid contains 90 percent of Methane gas and 10 percent of water liquid.

The distance before and after the orifice, in order to have a fully developed regime flow is  $8D$  [7].

The pressure was read before and after the orifice plate, in  $D$  and  $D/2$  centimeters respectively, and the velocity was read at the center point of the

orifice. The fluids enter the pipe at different Reynolds numbers but at a constant temperature of 300 K, and the walls are assumed to be adiabatic, so they will have no affect on the temperature of the fluid.

**4. Results and discussion:**

Figure 3 shows the mesh of the computational domain of the overall pipe, and the orifice plate mesh is shown in Figure 4.

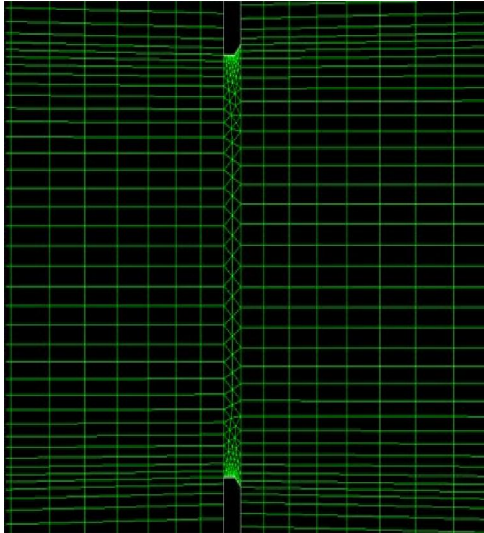

Figure 4. Orifice plate mesh

The results for different  $\beta$  ratios can be seen in the following tables and charts. We have to note that the results were compared by the data available in the “Flow measurement and instrumentation” handbook.

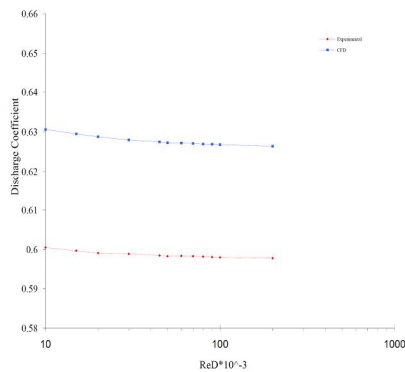

Figure 5. Comparison between experimental and computational calculated discharge coefficient for  $\beta = 0.25$ .

The results can be seen both as chart and table. The maximum error in this case is 5.012% that decreases while the Pipe’s Reynolds number increases and reaches to 4.784% which is absolutely acceptable.

Table 1. Comparison between experimental and computational calculated discharge coefficient for  $\beta = 0.25$ .

$Re_D \times 10^{-3}$	C (Exp)	C (CFD)	Error %
10	0.6005	0.6306	5.012
15	0.5997	0.6295	4.969
20	0.5991	0.6288	4.957
30	0.5989	0.628	4.859
45	0.5985	0.6275	4.859
50	0.5983	0.62728	4.843
60	0.5984	0.6272	4.812
70	0.5983	0.6271	4.813
80	0.5982	0.62695	4.806
90	0.5981	0.6269	4.815
100	0.598	0.6268	4.816
200	0.5978	0.6264	4.784

The formula calculated for this case is in the form of a MMF equation

$$C = \frac{a.b + e.Re_D^d}{b + Re_D^d} \quad \therefore$$

$$\begin{cases} a = 0.62549831 \\ b = 0.37210664 \\ e = 0.64120728 \\ d = -0.75425157 \end{cases} \quad (23)$$

With the use of this equation the discharge coefficient can be determined for any Reynolds number for example  $53.38 \times 10^{-3}$ , which was not possible before this.

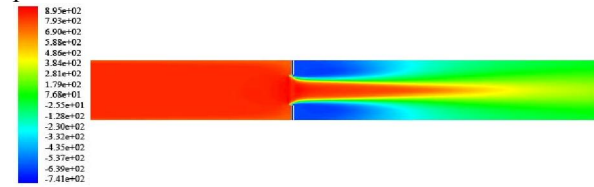

Figure 6. Pressure profile by means of CFD for  $\beta = 0.5$

The results can be seen both as chart and table. The maximum error in this case is 5.008% that decreases while the Pipe’s Reynolds number increases and reaches to 3.523% which is absolutely acceptable.

Table 2. Comparison between experimental and computational calculated discharge coefficient for  $\beta = 0.5$ .

$Re_D \times 10^{-3}$	C (Exp)	C (CFD)	Error %
10	0.619	0.65	5.00
15	0.615	0.6445	4.79
20	0.6125	0.6408	4.62
30	0.61	0.6359	4.24
45	0.6085	0.6327	3.97
50	0.6078	0.6306	3.75
60	0.607	0.6292	3.65
70	0.6065	0.6286	3.64
80	0.6062	0.6282	3.62
90	0.606	0.6278	3.59
100	0.6056	0.6275	3.61
200	0.6045	0.6258	3.52

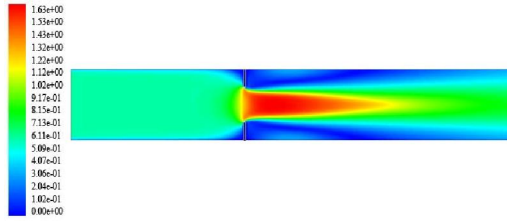

Figure 7. Velocity profile by means of CFD for  $\beta=0.5$

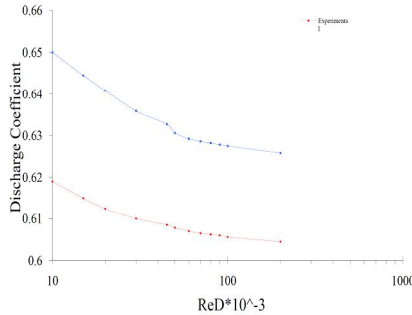

Figure 8. Comparison between experimental and computational calculated discharge coefficient for  $\beta=0.5$ .

The formula derived for this case is again in the form of a MMF equation:

$$C = \frac{ab + e \cdot Re_D^d}{b + Re_D^d} \quad \therefore \quad \begin{cases} a = 0.6227338 \\ b = 0.32695237 \\ e = 0.72014193 \\ d = -0.88352312 \end{cases} \quad (24)$$

Now by the use of mathematical methods and neural networking, we can determine an equation that can be applied over the range of  $0.25 \leq \beta \leq 0.5$  and  $10,000 \leq Re_D \leq 200,000$ .

$$C = \left[ \frac{ab + e \cdot Re_D^d}{b + Re_D^d} \right] \times \sqrt{1 - \beta^4} \quad \therefore \quad \begin{cases} a = 0.62415685 \\ b = 0.30651715 \\ e = 0.67147866 \\ d = -0.86214300 \end{cases} \quad (25)$$

The maximum error for equation 42 is assumed to be 7%. We have to note that the error will decrease while the Reynolds number increases. Using

equation 42 for  $\beta=0.35$  as an example, will result as in given in table 3:

Table 2. Comparison between the experimental and the determined discharge coefficient

$Re_D \times 10^{-3}$	C (Exp)	C (CFD)	Error %
10	0.606	0.633	4.45
15	0.6041	0.6307	4.40
20	0.6034	0.6287	4.19
30	0.602	0.6264	4.05
45	0.6018	0.6245	3.77
50	0.6016	0.6241	3.74
60	0.6015	0.6235	3.65
70	0.6015	0.6230	3.57
80	0.6013	0.6227	3.56
90	0.6012	0.6224	3.52
100	0.6008	0.6221	3.54
200	0.600	0.6209	3.48

**5. Conclusion:**

The objective of this research was to simulate the blood flow over the range of  $0.25 \leq \beta \leq 0.5$  and  $10,000 \leq Re_D \leq 200,000$ . The correlation was achieved through numerical methods using Fluent 6.0 software and is expressed as a function of the pipe's Reynolds number and the  $\beta$  ratio. As a result, each one of these non-ideal mechanisms can be analyzed independently from the influence of the other mechanisms.

**Corresponding Author:**

Ameneh Langari  
North Khorasan University of Medical Sciences,  
Bojnurd, Iran  
E-mail: [amenehlangari@yahoo.com](mailto:amenehlangari@yahoo.com)

**References:**

1. Netanel Korin et al., Shear-Activated Nanotherapeutics for Drug Targeting to Obstructed Blood Vessels, *Science*, 2012, DOI: 10.1126/science.1217815
2. ASME 3M. Differential producers used for measurement of fluids in pipes (orifices, nozzle, nozzle venturi, venturi). ASME, New York, 1985
3. ANSI/API 2530. Orifice metering of natural gas, American gas association, New York, 1985
4. McCabe, Smith, Harriot, Unit operations of chemical engineering. McGraw-Hill 2001; 15:729-736.
5. Hewitt G F. Measurements of two phase flow parameters. Academic, London, 1978.
6. Cao Z, Wiley D E, Fane A G. CFD simulations of net-type turbulence promoters in a narrow channel. *J. Membr. Sci.* 2001; 185()
7. ANSI/ASME MFC-2M, Measurement uncertainty for fluid flow in closed conduits. ANSI, New York, 1988.
8. Johnson RC. Calculations of real gas effects in flow through critical flow nozzles. *ASME J Basic Eng Series D* 1964; 86:519-26.



## Study of the health threatening mercury effective parameters for its removal from the aqueous solutions by using activated carbons

Maryam K. Hafshejani<sup>1</sup>, Farzaneh Khandani<sup>2</sup>, Ramin Heidarpour<sup>3</sup>, Amin Sedighpour<sup>4</sup>, Hamzeh Fuladvand<sup>5</sup>,  
Roohollah Shokuhifard<sup>6</sup>, Armin Arad\*<sup>7</sup>

<sup>1</sup>Shahrekord University of Medical Sciences, Shahrekord, Iran

<sup>2</sup>Ahar Branch, Islamic Azad University, Ahar, Iran

<sup>3</sup>Department of applied chemistry & chemical engineering, Sofian branch, Islamic Azad University, Sofian, Iran

<sup>4</sup>Department of engineering, Bam branch, Islamic Azad University, Bam, Iran

<sup>5</sup>Department of science, Khorramabad branch, Islamic Azad University, Khorramabad, Iran

<sup>6</sup>Department of science, Andimeshk branch, Islamic Azad University, Andimeshk, Iran

<sup>7</sup>North Khorasan University of Medical Sciences, Bojnurd, Iran

Corresponding author email: [arad1384@yahoo.com](mailto:arad1384@yahoo.com)

**Abstract:** A serious environmental threat from heavy metal ion pollution, especially mercury, has generated a great deal of attention in recent years. Mercury is one of the priority pollutant listed by USEPA as it can easily pass the blood-brain barrier and affect the fetal brain. High concentration of Hg (II) causes impairment of pulmonary function and kidney, chest pain and dyspnoea. Consequently, removal of mercury in water and wastewater assumes importance. In this review paper, we have evaluated the efforts which have been done for controlling the mercury emissions from aqueous solutions. According to the EPA agency, the tolerance limit for Hg (II) for discharge into inland surface water is 10µg/l and for drinking water is 1µg/l. Mercury (Hg) is one of the heavy metals of concern and has been found in the waste waters coming from manufacturing industry, and natural sources. Among several types of technology for removing of Hg in water (chemical precipitation, reverse osmosis, ion-exchange, etc.), adsorption is one of most frequently used. It is a complex process involving physical, chemical, and electrical interactions at sorbent surfaces. Therefore, in this study will investigate effective parameters such as pH, initial concentration and surface characteristic.

[Hafshejani MK, Khandani F, Heidarpour R, Sedighpour A, Fuladvand H, Shokuhifard R, Arad A. **Study of the health threatening mercury effective parameters for its removal from the aqueous solutions by using activated carbons.** *Life Sci J* 2012;9(4):1789-1791] (ISSN:1097-8135). <http://www.lifesciencesite.com>. 272

**Key words:** Mercury, Adsorption, Surface area, Activated carbon, Wastewater.

### 1. Introduction:

Heavy metals are known for their toxicity towards the aquatic environment. The discharge of effluents containing metals in the environment can constitute a threat to the aquatic life and have serious repercussions on the food chain. One of these metals is mercury [1-2]. Mercury exists in natural and process gases in elemental and metal salts forms. It is removed from the gases by reacting the mercury with a special impregnation on an activated carbon carrier. The mercury adsorbs to the reactant upon contact as the gas permeates the bed [1]. In past years, the presence of mercury received little attention in the environmental care. After the failure of several cold boxes, metallurgists determined that mercury corrosion was the source of the problem. Initially, it was believed that the mercury was present due to leaking instrumentation; however, further testing revealed mercury was present in the reservoir [2].

The adsorption of metallic ions from liquid has been studied for years, as well as the use of some

so-called available adsorbents. One of the low cost adsorbents is activated carbon. Activated carbon can be produced from a variety of carbonaceous raw materials, by either a physical or chemical activation methods. The adsorptive capacity of the final product depends on internal surface area, pore structure and surface chemistry that are defined by the nature of the starting material and production process [3]. Among other reported techniques for the treatment of wastewater containing organic mercury, adsorption process shows good potential and can be cost efficient [4]. A carbon sorbent selected for mercury capture should have a suitable pore size distribution and large surface area, as a result of activation process. A carbon sorbent selected for mercury capture should have a suitable pore size distribution and large surface area, as a result of activation process. Activated carbons are widely used as adsorbents for removing different pollutants from drinking water usually, micropores possess the majority of the active sites for mercury

adsorption, while mesopores act as transportation routes.

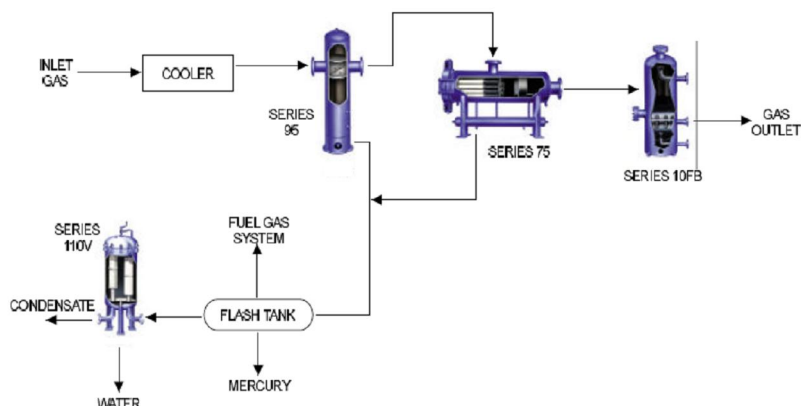

Figure 1 : Schematic diagram of Hg removal using activated carbon [1]

Adsorption of Hg by activated carbons at ambient temperatures (e.g. 238C) has been suggested to be a combination of chemisorption and physisorption, whereas chemisorption is prevalent at higher temperatures; e.g. 1400C [5]. Many factors have been found to influence the efficiency of mercury removal, including carbon characteristics, flue gas composition, and the presence of active components [6]. The aim of the present work was to study the review of mercury (II) removal in aqueous solution by activated carbon. At first, the adsorption of mercury present in aqueous solutions onto fly ashes was studied in static reactor. Then a leaching test was also carried out to estimate the capacity of solids to retain durably the mercuric ions. Finally, the surface of spent ash samples after the adsorption experiments were investigated to understand mechanisms involved by mercury adsorption. In this paper activated carbon design has been studied. Therefore, some parameters such as temperature, initial concentration, and pH and isotherm models have been investigated as effective parameters.

## 2. Methods and materials:

The method of preparation of activated carbon involves two steps: the carbonization of the raw carbonaceous material in an inert atmosphere and the activation of the carbonized product. Various types of activated carbons with different pore size distributions can be obtained by using different raw materials and activation methods. The activation methods can be classified into physical and chemical activation. The former involves heating the carbonaceous materials at a high temperature with a reactant such as CO<sub>2</sub> and H<sub>2</sub>O. The chemical activation involves heating the carbonaceous material at relatively low temperatures with the addition of

activating agents such as H<sub>3</sub>PO<sub>4</sub>, ZnCl<sub>2</sub>, K<sub>2</sub>CO<sub>3</sub>, and KOH [7–8].

The adsorption capacity of designed activated carbon towards Hg(II) ion is investigated using an aqueous solution of the metal. The adsorbate stock solution of the test metal is prepared by dissolving the necessary amount of HgCl<sub>2</sub> in distilled water. This stock solution is diluted to obtain standard solutions containing fixed Hg(II) concentration. Batch adsorption studies are carried out with fixed amount of adsorbent and fixed volume of Hg solution with the desired concentration at one defined by conical flasks. Stoppered flasks containing the adsorbent and the adsorbate are agitated for predetermined time intervals at room temperature on the mechanical shaker. At the end of agitation the suspensions are filtered through microporous filter paper. The amount of the Hg(II) in the final volume is determined by atomic adsorption device.

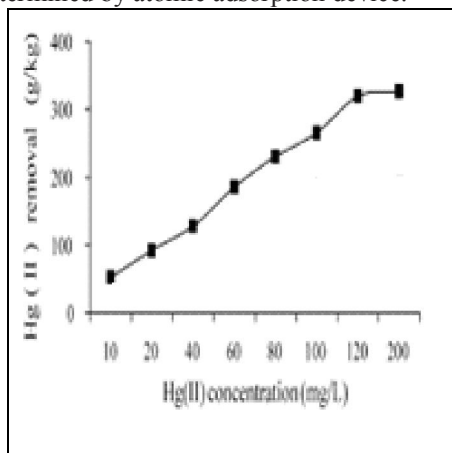

Figure 2. The effect of initial Hg (II) Concentrations on its removal by sewage sludge carbon [9].

### 3. Results

#### 3.1 Initial concentrations effect:

Mercury adsorption with some activated carbons showed that the Hg removal increased almost linearly with the enhancement of Hg (II) concentration (Figure 2).

It is clear that the sorption amount of ions increases with increasing the initial ion concentration. Also, the amount of metal ion absorbed sharply increases with time in the initial stage (usually 0–20 min range), and then gradually increases to reach an equilibrium value. A further increase in contact time had a negligible effect on the amount of ion sorption. The equilibrium time was found to be independent of the initial concentration [11-13].

#### 3.2 Adsorbent dose influence:

Mercury (II) adsorption increased with increase in the dosage of adsorbents. This increasing trend is ascribed to the introduction of more binding sites for adsorption on increasing the carbon dose.

The results of this experiment were used to develop a mathematical relationship between percentage removal and adsorbent dose by non-linear or linear optimization method.

Usually this equation can be used to predict the percentage Hg (II) removal for any activated carbons dose within the experimental conditions studied. One of the most important factors is correlation coefficient,  $r^2$ , obtained between the experimental and calculated percentage removal values must be near 1 [11]. Another effective factor is the surface area of adsorbent. By increasing in surface area the capacity of activated carbon will be increased so it can be removed a lot of mercury ions. By increasing the micro pores in activated carbons, the surface area will be increased. But interaction between ions maybe shows that the best pore size is meso pore.

#### 4. Conclusions:

The results of several investigations on the adsorption of mercury ion by activated carbons from aqueous solutions reveal that the best adsorbent is activated carbon with agricultural solid waste base. Employing activated carbons, adsorption will be increased by increasing initial Hg (II) concentration, pH of the solution, contact time and surface area of the adsorbent. With physical activation, carbonization

temperature in the adsorbent preparation step, and with chemical activation, types of chemicals used in the impregnation step are the most influencing parameters on the adsorption of mercury. Another important factor is the structure of porosity. The best size of pore is meso size.

#### Corresponding Author:

Dr. Armin Arad

North Khorasan University of Medical Sciences

Bojnurd, Iran

E-mail: [aarad1384@yahoo.com](mailto:aarad1384@yahoo.com)

#### References:

1. [http://www.perryequipment.com/sales/new\\_application\\_data\\_sheets/EL-GS-AD-18/EL-GS-AD-18.pdf](http://www.perryequipment.com/sales/new_application_data_sheets/EL-GS-AD-18/EL-GS-AD-18.pdf)
2. <http://www.tigg.com/mercury-removal.html>
3. Yardim M F, Budinova T, Ekinci E, Petrov N, Razvigorova M, Minkova V. Removal of mercury (II) from aqueous solution by activated carbon obtained from furfural. *Chemosphere* 2003; 52:835–841.
4. Rio S, Delebarre A, Removal of mercury in aqueous solution by fluidized bed plant fly ash, *Fuel* 82 (2003) 153–159.
5. Skodrasa G, Diamantopoulou Ir, Sakellaropoulos G P. Role of activated carbon structural properties and surface chemistry in mercury adsorption. *Desalination* 2007; 210:281–286.
6. Logsdon G S, James M S. Mercury removal by conventional water-treatment techniques. *J. Am. Water Works Assoc.* 1973; 65:554.
7. Kelleher B P, O'Callaghan M, Leahy M J, O'Dwyer T F, Leahy J J. The use of fly ash from the combustion of poultry litter for the adsorption of chromium(III) from aqueous solution. *J. Chem. Technol. Biotechnol.* 2002; 77:1212–1218.
8. Kadivelu K, Kavipriya M, Karthika C, Vennilamani N, Pattabhi S. Mercury(II) adsorption by activated carbon made from sago waste. *Carbon* 2004; 42:745–752.
9. Shiue A, Den W, Kang Y H, Hu S C, Jou G T, Lin C H, Hue V, Lin S I. Validation and application of adsorption breakthrough models for the chemical filters used in the make-up air unit (MAU) of a cleanroom. *Building and Environment* 2011; 46:468–477.
10. Popescu M, Joly J P, Carre J, Danatoiu C. Dynamical adsorption and temperature-programmed desorption of VOCs (toluene, butyl acetate and butanol) on activated carbons. *Carbon* 2003; 4:739–748.
11. Zhang F S, Nriagu J O, Itoh H. Photocatalytic removal and recovery of mercury from water using TiO<sub>2</sub>-modified sewage sludge carbon. *Journal of Photochemistry and Photobiology A: Chemistry* 2004; 167:223–228.
12. Ruiz C G. Mercury (II) removal from aqueous solutions by nonviable bacillus sp. from a tropical estuary. *Bioresource Technology* 2006; 97:1907–1911.
13. Inbaraj B S, Sulochana N. Mercury adsorption on a carbon sorbent derived from fruit shell of Terminalia catappa. *Journal of Hazardous Materials B* 2006; 133:283–290.

10/6/202

## Assessment of Different Surface Treatments Effect on Surface Roughness of Zirconia and Its Shear Bond Strength to Human Dentin

Manal R. Abu-Eittah

Lecturer, Fixed Prosthodontics Department, Faculty of Dentistry, Minia University, Minia, Egypt.

[manalrafei@yahoo.com](mailto:manalrafei@yahoo.com)

**Abstract: Aim of the study:** The aim of this study was to assess the different surface treatments effect of yttrium oxide partially stabilized tetragonal zirconia polycrystal (Y-TZP) dental ceramic on its surface roughness and shear bond strength to dentin. Surface topography of zirconia was studied with atomic force microscopy AFM. **Materials and Methods:** A Total of 35 discs of zirconia dental ceramic of 5mm diameter and 2mm thickness were used in this study and divided into 5 groups according to surface treatments as follows: gp1-C: no treatment, gp2-G :grinding with 600 grit diamond disc, gp3- SB : samples were sandblasted with 50  $\mu\text{m}$   $\text{Al}_2\text{O}_3$  particles, gp4-SC : samples were treated with modified tribochemical protocol, and gp5-AE : samples were immersed in experimental hot etching solution of Hcl and ferric chloride for 15 minutes. The surface roughness  $R_a$  of all samples groups was measured by a profilometre. The surface topography was inspected by atomic force microscopy AFM. Freshly extracted molars were collected. Their crowns were sectioned using a diamond disc to obtain occlusal deep dentin flat surfaces. The roots of the teeth were invested within acrylic resin blocks. The zirconia samples were cemented to the dentin surface by RelyX™ Unicem aplicap™, light-cured according to manufacturer instructions. The blocks were stored for 21 days in distilled water at room temperature. All specimens were subjected to 5000 thermo-cycles between 5 and 55°C, and thereafter, subjected to shear bond strength test (1 mm/min). Data of surface roughness and shear bond strength were statistically analyzed. **Results:** 1- No significant difference in surface roughness  $R_a$  of groups 1, and 2, while the highest recorded  $R_a$  values were in groups 5,  $p < 0.05$ . 2- Shear bond strength of gp-5 (acid etching) was the significantly highest recorded value (24.3MPa $\pm$ 3.2) while there was no significant difference between groups 1, and 2 with the least recorded bond strength  $p < 0.05$ . 3- Modified tribochemical procedure improved shear bond strength (13.4 $\pm$ 4.5),  $p < 0.05$ . **Conclusions:** 1- Although it needed much time to be performed, yet, proposed modified tribochemical technique is valid method in increasing Y-ZTP /dentin bond strength and recommended to be applied rather than conventional tribochemical method.. 2- The use of hot etching solution of Hcl and ferric chloride  $\text{FeCl}_3$  is recommended as an effective and simple method which could be performed easily in labs to modify surface of zirconia chemically and mechanically, so that, enhance bonding to dentin surface even after water storage and thermo-cycling. 3- Self adhesive cement RelyX Unicem, produced a comparable results to resin cement with the advantages of reduced time and sensitive steps of conventional bonding procedure.

[Manal R. Abu-Eittah. **Assessment of Different Surface Treatments Effect on Surface Roughness of Zirconia and Its Shear Bond Strength to Human Dentin.** *Life Sci J* 2012;9(4):1792-1803] (ISSN:1097-8135). <http://www.lifesciencesite.com>. 273

**Keywords:** Zirconia, self adhesive cement, surface roughness, shear bond strength

### 1. Introduction

The increased popularity of all-ceramic materials as an alternative to metal ceramic restorations is attributed to their excellent aesthetics, chemical stability, and biocompatibility.

New high-performance non-etchable ceramics, such as alumina and zirconia, are becoming common in indirect restorations<sup>(1)</sup>. The use of zirconia-based ceramics for dental restorations has gained popularity due to their superior fracture strength and toughness compared to other dental ceramic systems<sup>(2)</sup>. Zirconia is polymorphic in nature that displays a different stable crystal structure at different temperatures with no change in chemistry. It exists in three crystalline forms: monoclinic at low temperatures, tetragonal above 1170°C and cubic above 2370°C<sup>(3,4)</sup>. Researchers found that zirconia

alloying with lower valance oxides such as CaO (calcia), MgO (magnesia),  $\text{Y}_2\text{O}_3$  (yttria), or CeO (ceria) can retain tetragonal or cubic phases in the room temperature depending on the amount of these oxides. However, the tetragonal form is in fact 'metastable' at the room temperature<sup>(5)</sup>

Zirconia materials differ from other high strength dental ceramics because of their distinct mechanism of stress-induced transformation toughening, which means that the material undergoes micro structural changes, volume increase 3-4%, when submitted to stress<sup>(6)</sup> while most ceramics are very brittle and cannot withstand more than a 0.1% change in volume.

The addition of 8 mol % MgO to  $\text{ZrO}_2$  results in the creation of a stable matrix of cubic phase grains, with a metastable phase of tetragonal crystals

that precipitate during cooling. In the  $Y_2O_3 - ZrO_2$  system, the addition of 2–3 mol %  $Y_2O_3$  to  $ZrO_2$  produces a meta-stable matrix of tetragonal crystals referred to as yttria stabilized tetragonal zirconia polycrystals (Y-TZP)<sup>(7,8)</sup>. Y-TZP ceramics can actively resist crack propagation through transformation from a tetragonal to a monoclinic phase at the tip of a crack, which is accompanied by a volume increase<sup>(6)</sup>. The mechanical properties of Y-TZP materials, such as flexural and fracture resistance, are considerably higher than those of other dental ceramics. The flexural strength of Y-TZP ceramics can reach values from 700 to 1200 MPa<sup>(9,10)</sup>. These values exceed the maximal occlusal loads during normal chewing<sup>(9)</sup>. It has a fracture toughness of 9–10 MPa/mm<sup>2</sup>, which is almost twice the value obtained for alumina-based materials and almost three times the value demonstrated by lithium disilicate-based ceramics<sup>(11)</sup>. Zirconia or “Ceramic steel” has been used extensively in fabrication of extra-coronal restorations especially, crowns, abutments and retainers for implant supported fixed partial denture in esthetic zone, and long span fixed partial dentures<sup>(12)</sup>. Y-TZP materials might also exhibit fracture resistance higher than 2,000 N, which is almost twice the value obtained for alumina-based materials and at least three times the value demonstrated by lithium disilicate-based ceramics<sup>(13)</sup>.

One of the inherent weakness points of Zirconia is the lack of durable and adequate bond with tooth structure, as the material is chemically inert.

Different luting strategies (i.e. conventional cements, glassionomer cements, self-adhesive cements) have been proposed for luting zirconia frameworks in the attempt to ensure retentive, and well adapted restorations<sup>(13,14)</sup>

Previous investigations have been focused on different chemo-mechanical surface treatments in order to optimize the cement/zirconia bonding mechanism. The rationale of these conditioning processes relies on increasing the surface area available for bonding and establishing stronger and durable restorations<sup>(15,16)</sup>.

It is important for high retention, prevention of microleakage, and increased fracture/fatigue resistance, that bonding techniques be optimized. Strong resin bonding relies on micromechanical interlocking and adhesive chemical bonding to the ceramic surface, which requires surface roughening for mechanical bonding and surface activation for chemical adhesion. Bonding to traditional silica-based ceramics, generally employing both mechanical and adhesive retention, has been well researched, and cement bond strengths are predictable. Unfortunately, the composition and physical properties of  $ZrO_2$

differ from conventional silica-based materials like porcelain. Zirconia is not readily etched by HF, and requires very aggressive mechanical abrasion methods to be used to increase surface roughness<sup>(17-19)</sup>. Therefore, in order to achieve acceptable cementation in a wide range of clinical applications, alternate surface modification methods, ideally utilizing chemical adhesion in addition to mechanical retention, are required for zirconia ceramics.

Several studies were performed to investigate the mechanical properties of zirconia-reinforced ceramics as well as the techniques to enhance the bond strength of luting cement to the ceramic surface<sup>(20,25)</sup>. It was reported that conventional acid etching had no positive effect on the resin bond to zirconia-reinforced ceramics. **Derand and Derand(2000)**<sup>(26)</sup> proved that an autopolymerizing resin cement exhibited the highest bond strength regardless of the surface treatment (silica coating, airborne particle abrasion, HF etching or grinding with diamond rotary instruments). The same results were previously reported by **Kern and Wegner(1998)**<sup>(27)</sup> who achieved a durable bond to zirconia-reinforced ceramic only by using resin composites containing phosphate monomers (MDP). The use of phosphoric acid primers or phosphate-modified resin cements has been shown to produce silane-like adhesion, through a similar type of hydroxylation-driven chemistry. However, a controversial results also have been reported, as recorded bond strength values in the literature through the use of these agents are generally lower than the values reported for tribochemical silica coating, coupled with silane and resin cement<sup>(23)</sup>

It was also reported that the infiltration of fused glass micro-pearls to the surface of  $ZrO_2$  has been shown to increase the bond strength of resin cements to  $ZrO_2$ . In these studies, a slurry of micro-pearls was painted on a  $ZrO_2$  surface and fired in a furnace. The fused glass film increased surface roughness of  $ZrO_2$ , allowing increased micro-retention. The silica-rich film also allows for silanization of  $ZrO_2$  before bonding, making it possible to form siloxane bonds to resin cement. The results showed that use of this fused micro-pearl film significantly increased the bond strength of  $ZrO_2$  (11.3–18.4 MPa)<sup>(24,25)</sup>. Clinicians are still confused regarding the most effective way to treat the fitting surface of indirect ceramic restoration before placement with various adhesives and luting cements. The best method to promote a durable bond between the ceramic and tooth structure is still unknown.

Scanning electron microscope, SEM, was used routinely to study the topography of any surface treatments on polymers, alloys, ceramics or any related materials. Because ceramics are insulating substrates, a conductive material, mostly by gold

sputtering, must be coated on ceramic surface in order to examine the surface structure by SEM which may to some extent modify the surface topography and misleading the observer. In the last few years the atomic force microscope AFM was used to study the surfaces of insulating materials with no conductive coating materials. This mathematical tool can provide a new way to account for the complexity of the topographical pattern of the treated material surface, which can in turn depend on the surface treatment conditions. In fact, it is generally accepted that the measures of roughness from the distribution of heights (z) alone without any information on their spatial localization on the (x, y) plane is insufficient to completely describe the surface roughness<sup>(21)</sup>. The technique of AFM enables featuring and highlights the edges, steepness, sharpness, depressions, elevations or pores and all of the surface properties in microns and on the nano scale.

The success to chemically activate and functionalize the surface of zirconia appears to be mandatory in enhancing adhesive bonding to the substrate or the tooth structure. It is of great importance to study the effect of some proposed surface treatments on the surface topography of zirconia re-inforced ceramics and correlate with the bonding strength to tooth structure.

Therefore, the aim of this study was to evaluate the effect of some surface treatments on the surface roughness of zirconia reinforced ceramic in addition, the shear bond strength of zirconia Y-TZP discs to the dentin of freshly extracted teeth was studied. The surface topography of zirconia after surface modification was studied with AFM.

## 2-Materials and Methods:

### Composition of Zirconia:

To standardize the shape and size of the samples, a split stainless steel mould with five shaped disc spaces was fabricated. The parts of the mould were fixed together with the help of two stainless steel pins at each terminal of the mould. Each disc has a diameter of 5mm and thickness of 2mm.

Zirkon- Zahn, the material studied, is a core veneered all ceramic system Hot isostatic pressed (HIP) blanks in which  $ZrO_2$  is the main component 90%, 5-5.5%  $Y_2O_3$  and traces of  $Al_2O_3$ ,  $SiO_2$ ,  $Fe_2O_3$ , and  $Na_2O$  (less than 2%) were used. The core substructure is manually milled from partially sintered Zirconia blanks following the shape and dimension of a resin mock-up frame

This study was conducted on the core material only. Core samples were constructed as follows:

### 2-1 Construction of resin mock-up frame:

A thin layer of Vaseline (Unilever Dept ER, UK) was applied to the inner surface of the stainless steel

mould. The special resin (Zirkonzahn World Wide - An der Ahr 7 - 39030 Gais/South Tirol (Italy) supplied by the manufacturer was packed in the mould forming disc with the specified dimensions.

The formed resin disc was placed on the frame template disc and its outline was marked. Two connection points were also marked joining the mock-up disc to the external frame template. A tungsten bur was used to cut out and separate the outlined drawn disc. The mock-up resin disc frame was placed instead and fixed in position using Attak Flex Gel (Zirkonzahn World Wide - An der Ahr 7 - 39030 Gais/South Tirol (Italy).

Milling process: The template was then inserted in the milling table and locked. In the other compartment a Zirconia blank of suitable size was selected and placed. The manual milling process was started and the discs were milled following the dimensions and shape of the resin mock-up disc. Part of the connection base was left intact to hold the disc during later sintering.

### 2-2 Sintering Process:

Samples were dried under the infrared drying lamp; Zirkonlampe 250 (Zirkonzahn World Wide - An der Ahr 7 - 39030 Gais/South Tirol (Italy). The discs were carried to the Zirkonzahn furnace for 8 hours to complete the sintering process following the manufacturer's instructions.

35 samples used in this study were milled following the same procedures and instructions, which were given as mentioned previously from the manufacturer.

### 2-3 Samples grouping n=7, and surface treatments:

Group1-C(control) : samples were left as sintered without any modification of its surface texture.

Group2-G: samples were ground with 600 grit diamond disc (Fuji star, Japan) under water coolant then, ultra-sonically cleaned in distilled water, left to dry in air.

Group3-SB: samples were Sandblast with 50  $\mu m$  aluminum trioxide (Remfert, Germany). Particles were blasted with pressure of 2.8 bar for 10 sec. from a distance of 10 mm in a circular movement. Samples were then ultrasonically cleaned with distilled water, left to dry. Then samples were coated by 97.7 % 3-methacryloxy-propyltrimethoxysilane (Alfa Aesar, Johnson Matthey Company, U.S.A), left for 5 minutes to polymerize in air.

Group 4-SC : A modified laboratory tribochemical silica coating, was performed as follow: Airborne particle abrasion with 110  $\mu m$  aluminum trioxide  $Al_2O_3$  particles for 15 seconds followed by immersion in a saturated emulsion of Aluminum sulfate and Urea for one hour. The

samples were introduced into a ceramic furnace (Jelrus v.i.b.300,USA) and heated to 95-98C° for one hour for the purpose of beginning of calcinations (removal of water and beginning of x alumina formation) . Although maturation is completed between 300-600C°, this temperature was not applicable in this study to prevent the adverse effect of tetragonal phase transformation at high temperature. Fortunately, seeding of Al<sub>2</sub>O<sub>3</sub> began at nearly 60C°. In addition ,the proposed steps were believed to improve homogenization of alumina particles and increase attachment, binding of the particles together with the zirconia substrate <sup>(28)</sup>, this step was followed by cleaning of the samples in ultrasonic water path to remove all of the loose Al<sub>2</sub>O<sub>3</sub> particles. The following steps were blasting the surface with high purity aluminum trioxide particles,30 µm modified by silica (SiO<sub>2</sub>) with blasting pressure of 2.8 bars for 15 seconds. Samples were then immersed in saturated solution of silicon oxide, prepared from solution of tetraethyl - orthosilicate in ethanol and ammonium hydroxide. Addition of predetermined drops Hcl to adjust the pH at 7<sup>(29)</sup> Samples were Introduced again into the furnace and heated to 100C° for 15minutes, this step was done to enhance maturation and fixation of the silica layer to the under lying ceramic substrate <sup>(30)</sup> Samples were then, coated with 97.7 % 3-methacryloxy-propyltrimethoxysilane (MPS),(Alfa Aesar, Johnson Matthey Company, U.S.A), left for 5 minutes to polymerize in air.

The entire coated surface loses its smoothness gloss, due to silica deposition on the ceramic surface.

Group 5-AE: samples were immersed in the following laboratory prepared solution: 800ml ethanol, 200ml 37% conc. Hydrochloric acid Hcl, and 2g of ferric chloride FeCl<sub>3</sub>,all of the chemical reagents are driven from BDH. chemically analar (high purity). The solution was heated in a Pyrex beaker till 100 C° and the beaker was then immersed in other larger beaker full with distilled water previously heated to boiling temperature 100 C°.A thermostat was used to adjust the corresponding temperature. The zirconia samples were immersed for 15 minutes with continuous shaking with multi-wrist shaker,( Lab. Line instruments, Inc. USA), any drop in temperature was compensated with addition of boiled water to the external beaker. At the end of the predetermined time, the samples were removed from the etchant solution and washed under running water and dried with oil free air syringe and left in a desiccator, (Duran laboratory glassware, Germany).

#### 2-4 Surface roughness measurements (Ra µm):

Randomly selected samples from each group were chosen to surface roughness study. The sample was attached by a special holder on the stainless steel

table then the profilometer stylus (Surftest.SJ-201, Mitutoyo corp., and Kawasaki, Japan) scanned the whole sample surface longitudinally and horizontally, recording 10 readings in each axis. The final recorded figure is the mean of these 10 readings.

#### 2-5 Atomic force microscopy topography study:

A nanoscope Auto-prope CP-Research,Thermo-microscobe AP-0100,Borregas Avenue Sunnyvale, California USA, of tapping mode was used to scan the surface of the samples, scanning speed was 1 Hz.The 3D photos was displayed on a computer screen with a soft ware,proscan1.8 and resolution of 256x 265 line and soft ware for image processing IP2.1. The surface roughness of the scanned area of each specimen has been evaluated as the root mean square (RMS) value, R<sub>q</sub>,of the distribution of heights in the AFM topographical images was calculated in an area of 20x20 µm and for an area of 4x4 µm, according to the general surface roughness as viewed with the microscope before starting the scan i.e. if the surface characterized with high or sharp tops, the stylus propping the surface will not be able to move freely to record the whole depth and full heights of the surface, so the scanned area has to be reduced according to manufacturer instructions.

#### 2-6: Teeth preparation:

Freshly extracted posterior second molars were used in this study. The teeth were stored in glycerin and ethanol until use (not more than one week to preserve the tooth structure elasticity, and not to affect the bonding). The occlusal surface of the teeth was cut immediately before cementation with sharp diamond disc under copious water irrigation. The resultant cut tooth surface ensures exposure of the deep dentin surface. Flattening of the resultant dentin surface is performed carefully with size 4 diamond disc. Before cutting the occlusal surface of the teeth, they were invested from the root side into self cure acrylic resin blocks.

#### 2-7 Cementation of zirconia discs to the tooth structure:

Rely X Unicem, 3M ESPE St. Paul, USA, self adhesive cement (Aplicap capsules) was used in this study. Immediately prior to bonding procedures, occlusal surface of samples underwent 600-grit silicon-carbide disc cutting to create fresh smear layer. The samples were cemented to the dentin as follows : equal volume of base and catalyze pastes were mixed on a paper pad, for 10 s, application of the cement by a suitable instrument which was spreaded on the ceramic sample and the dentin surface as well,the sample was fixed on the tooth with gentle finger pressure for 20 seconds,removal of excess cement with suitable instrument then, curing with light emitting diode LED( Ortholux™ LED 3M,

Unitec, USA) of intensity of up to 1000mw/cm<sup>2</sup> for 40 s (groups 1, 2). For groups 3, 4 and 5, application of silane (97.7% 3-methacryloxy-propyltrimethoxysilane (Alfa Aesar, Johnson Matthey Company, U.S.A) on the ceramic samples and left to air dry for 5 minutes, prior to application of adhesive cement according to manufacturer instructions.

**2-8 Aging of samples:**

The samples of each group were stored in a distilled water at room temperature for 21 days then subjected to thermo-cycling (at 5-55C for 5000 cycles, (Porto-Tech; version 2.1A, Portland, Ore) according to (ISO Standard 10477).<sup>(31)</sup>

**2-9 Shear bond strength:**

The bond strengths of the samples after thermo-cycling were assessed by shear bond strength testing. Specimens were mounted in a jig of the computer controlled universal testing machine (Lloyd LRX; Lloyd Instruments, Fareham, UK) and shear force was applied by a mono-beveled chisel at a crosshead speed of 1.0mm/min, at the adhesive interface until failure occurred. The load was recorded in Newton then divided by the interfacial area of bonding (radius of the disc) to express the bond strength in MPa.

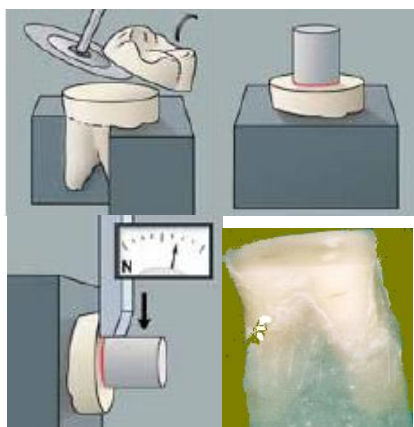

Figure1: SBS. Set up test (pamphlet of RelyX Unicem) + experimentally prepared tooth.

**Statistical Analysis:**

The results of surface roughness and shear bond strength were statistically analyzed using SPSS version 17, comparison between groups was done with one way Anova, multiple comparisons to test the inter-relation between groups to determine which group that affect the results using Post Hoc and Tukey-t-test at confidence level of 95%.

**3-Results:**

Table 1 shows the different values of surface roughness and the shear bond strength of all groups

,superscript of the same letters indicating statistically not significant values,  $p < 0.05$ . The surface roughness of group 5 (acid etching) was  $54.5 \pm 6.8$  which is doubled nearly 25 times more than control group samples ( $2.3 \pm 1.4$ ). Table 2 shows the Anova statistical test between the groups and within the groups, F value is significant for, shear bond strength and surface roughness values. Surface treatments had a strong effect on surface roughness of the groups as well as on shear bond strength, but to a lesser extent.

Figures 2, and 3 illustrate that group 5 (acid etching) has very high surface roughness value compared to the other groups ( $54.5 \pm 6.8$ ) and also the highest recorded shear bond strength ( $24.3 \pm 3.2$ ). From these figures, it is clear that when the surface roughness was doubled 25 times, the bond strength doubled nearly 8 times.

**Table (1):** statistical analysis of surface roughness and the corresponding shear bond strength values.

		surface roughness	shear bond strength(MPa)	P value
control	Mean	2.3000 (a)	3.054(s)	$P < 0.05$
	Std. Deviation	1.41803	1.99403	
Grinding tool	Mean	3.671(a)	4.431(s)	
	Std. Deviation	1.17149	2.36731	
group3	Mean	7.5043 (b)	8.4371(E)	
	Std. Deviation	3.2531	2.84825	
group4	Mean	12.750 (c)	13.4286(E)	
	Std. Deviation	4.25979	4.54994	
group5	Mean	54.5 (d)	24.300 (M)	
	Std. Deviation	6.86339	3.21388	

**Table (2):** statistical results of all groups, one way Anova

		Sum of Squares	df	Mean Square	F	Sig.
surface roughness	Between Groups	26056.947	4	6514.237	326.714	.000
	Within Groups	598.160	30	19.939		
	Total	26655.107	34			
shear bond strength	Between Groups	441.180	4	110.295	85.123	.000
	Within Groups	38.871	30	1.296		
	Total	480.051	34			



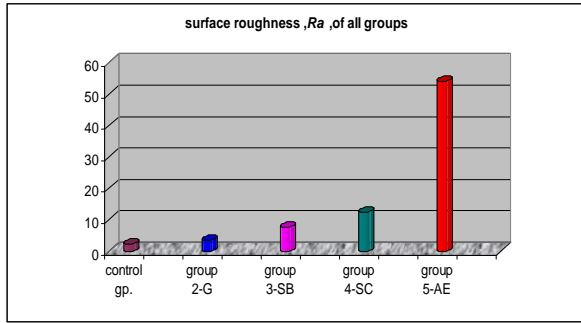
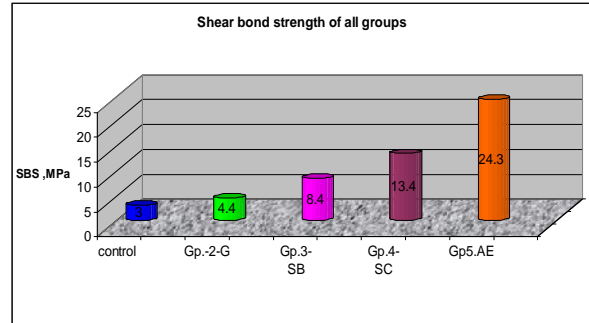

**Figure 2:** Surface roughness Ra, after surface treatment for all groups.

**3-2 Results of atomic force microscopy AFM:**

Figures 4, and 5 shows the surface topography as traced by the AFM, the roughness of the scanned area, 20µm., the surface appeared smooth except some sharpness which was interpreted as attached powder, or dust from the laboratory fabrication procedures, and for gp2-G very minute sharpness and scratches appeared. Generally the recorded average roughness, in small scanned area, 20µm, Ra was 402 nm, for control group while for group2, the recorded Ra was 600nm. The recorded highest peak area in the histogram is not statistically different compared with the control.

Figures 6 and 7 showing the roughness resulted from sand blasting (group3) and modified



**Figure3:** Shear bond strength MPa, of all groups

tribochemical coating, it is clear that surface roughness increased, as much more peaks of sharp irregularities corresponds to the coated alumina modified silica particles which remains well attached to the surface even after ultrasonic washing. The recorded roughness peak in the histogram in group3 was 890nm, while it was 1.4µm in group4 with much more thickness in z- plane axis.

In group5, fig 8, the surface is full of deep, wide valleys and concavities as well as sharp tops, irregularities with the highest recorded surface roughness histogram, within the scanned area, 2.84µm, as well as increased thickness in z-plane axis. Acid etching procedure yielded a wide surface area available for the bonding cement to penetrate and interlocked within the rough surface.

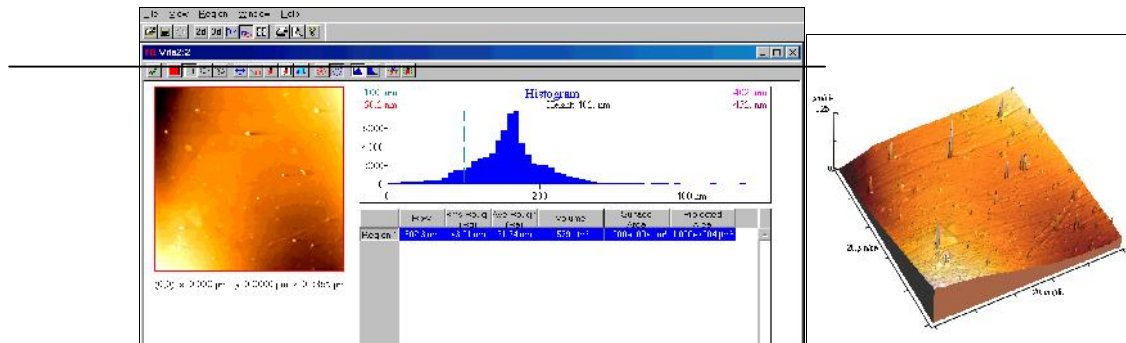

**Figure4:** Surface roughness parameters as recorded from AFM, 2D and 3D AFM photo of control group

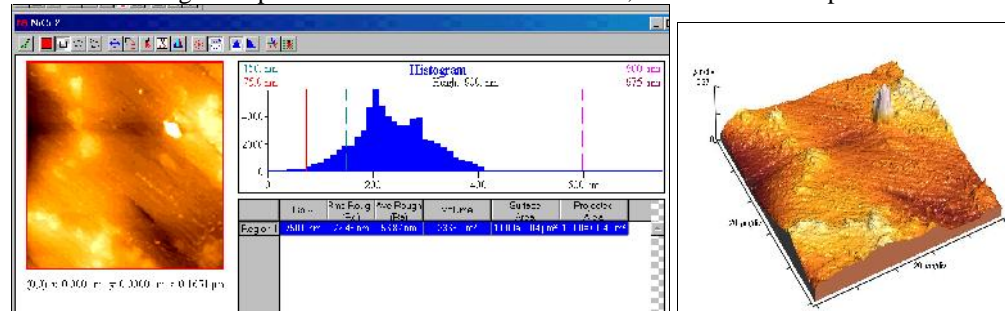

**Figure 5:** Surface roughness parameters as recorded from AFM, 2D and 3D AFM photo of group 2-G

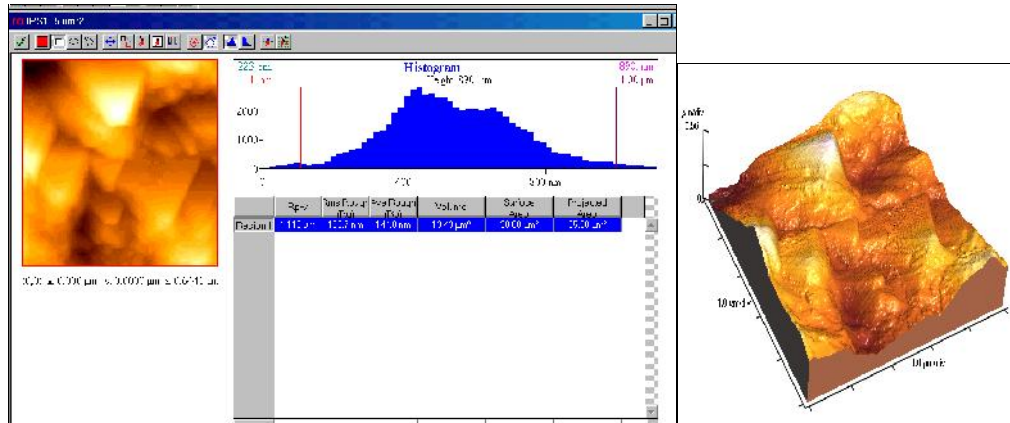

**Figure 6:** Surface roughness parameters as recorded from AFM, 2D and 3D AFM photo of group3-SB (sand blasting)

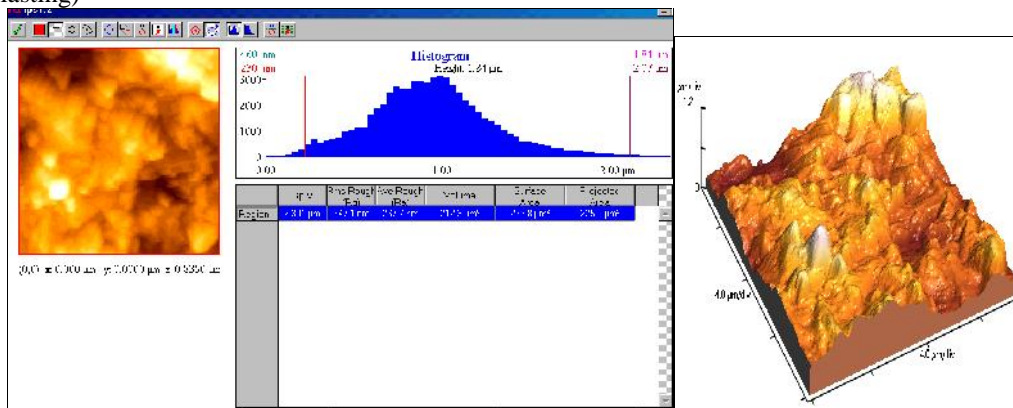

**Figure 7:** Surface roughness parameters as recorded from AFM, 2D and 3D AFM photo of group 4-SC (modified tribochemical technique).

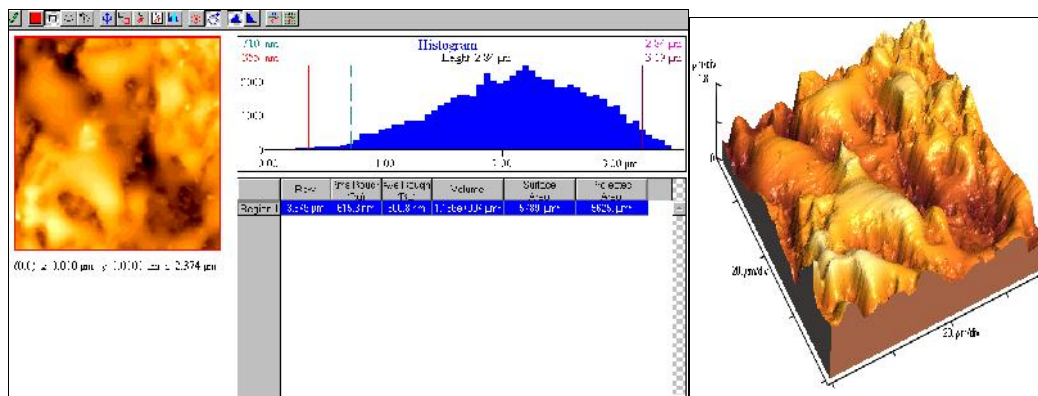

**Figure 8:** Surface roughness parameters as recorded from AFM, 2D and 3D AFM photo of group 5-AE (acid etching).

**4-Discussion:**

Non-silicate ceramics, especially zirconia, have become a topic of great interest in the field of prosthetic and implant dentistry. Although its mechanical properties are superior than other available ceramics, problems with use of zirconia-based ceramics in achieving suitable adhesion with

tooth structure always arises, especially in stress areas of the oral cavity.

Traditional adhesive techniques used with silica-based ceramics do not work effectively with zirconia, because of their lack of silica and glass phase, the responsible elements in providing good bond strength in traditional silicate ceramics. Several

investigations are being utilized clinically to solve this problem, and other approaches are under investigation. Most focus on surface modification of the inert surfaces of zirconia.

Zirconium is an inert element, 3d, 4s, and 4p orbitals are completely filled, and 4d orbital is of high energy level and not involved in common reaction at ordinary chemical condition<sup>(30)</sup>. The ability to chemically functionalize or activate the surface of zirconia appears to be critical in achieving adhesive bonding. Some literatures suggest the use of air abrasion or tribochemical coating prior to adhesive cementation, the effect of those surface treatments on the mechanical properties of Y-TZP materials is controversial, and both positive and negative results have been described in the literature<sup>(32,33)</sup>.

In most of the previous studies the bond strength of adhesive resin materials to Y-TZP ceramics was studied. Shear and tensile bond strength tests were the methods most frequently used in those investigations<sup>(34-36)</sup>. In both methods, the specimens had only one adhesive interface to be tested, that is, between the ceramic and resin-based materials. However, in the clinical situation, both interfaces between the ceramic and adhesive restorative material and between the adhesive restorative material and tooth structure are present.

Thus, the performance of the complex tooth structure- adhesive resin—zirconia ceramic must be tested, as there are much complicated factors to affect the bonding strength to the tooth structure. Therefore the results which did not include the important tooth-restoration interface may be not clinically reliable.

In this study, hot iso-static pressed (HIP) yttrium-oxide-partially-stabilized zirconia poly crystal blocks machinery fabricated were used. The effect of several methods to modify the surface of zirconia to improve bonding with dentin namely, grinding surface with carbide disc, air abrasion technique with  $Al_2O_3$ , modified protocol of the tribochemical technique, and acid etching with solution of 27% HCl and ferric chloride.

The selected cement, a self adhesive cement, RelyX Unicem, which was used to decrease the sensitive steps of bonding procedures. Self-adhesive resin cements, do not require tooth pre-treatment, therefore simplifying the clinical steps during the cementation procedures of crowns/ fixed partial dentures. The cement paste is very acidic and has hydrophilic properties. Therefore it shows a higher moisture tolerance than multi-step composite cements. During setting of the cement, a strongly cross-linked cement matrix with hydrophobic properties develops through the cross linkage polymerization reaction. A low linear expansion and

low solubility are the results and lead to the long-term stability which plays a central role especially for all-ceramic restorations. Additional advantages of these products are the decrease or elimination of post-operative sensibility, as well as lesser susceptibility to moisture, as reported by **Mazzitelli et al. 2008**<sup>(37)</sup>. By elimination of other influencing bonding variables related to etching and or priming of dentin, the results of bonding strength were confined to proposed surface treatments only, with no other influencing factors.

The results of this study showed that no significant difference in shear bond strength between control group with no surface treatment and the use of grinding tool, as there was no difference in surface topography, and the resulted roughness was incapable of providing the adequate micromechanical bonding with the cement and tooth structure. The results were in accordance with other researchers who reported that surface grinding techniques, using conventional grinding tools and bonding with resin cements, have no significant effect on increasing the bond strength of zirconia to resin cements. The low surface energy and inertness of zirconia surface provide very low bond strength with tooth structure after 5000 thermo-cycling and storage in water.<sup>(20,21,25)</sup>

Silane coupling agents (silanes) are well-known to form covalent chemical bonds between dissimilar matrices, i.e glassy ceramics (oxides) and organo-functional monomers in the adhesive cement.<sup>(38)</sup>

In this study, the silane monomer with the methacrylate functionality, 3-methacryloxypropyltrimethoxy silane, which is widely used in dentistry, was selected in treatment of samples of group 3 and 4. Also in group 5 to improve wettability of the etched zirconia surface, in addition after etching, there will be an ionized free components and oxides of trace elements which could share in bonding process. However, silanes cannot react directly with the chemically inert zirconia. Silanes are also believed to promote surface wetting, which enhances potential micromechanical retention with low viscosity resin cements<sup>(39,40)</sup>.

In group 3, sand blasting with  $Al_2O_3$  increased the bond strength significantly  $8.4 \pm 2.8$  in comparison to the control group. Airborne-particle abrasion has been shown to be a good method for cleaning and roughening the zirconia surface after clinical try-in procedures, since the contamination with saliva is known to decrease the bond strength. **Yang et al., 2008; Yang et al., 2007**<sup>(41,42)</sup> stated that airborne particle abrasion with alumina creates surface roughening and significantly improved Zirconia-resin bond strength

Un-fortunately, these techniques can create surface microcracks<sup>(43, 44)</sup>. That may act as crack initiation sites that can decrease strength. Moreover, surface grinding also results in a tetragonal to monoclinic phase transformation on the surface of zirconia. This can theoretically produce a compressive stress layer that counteracts the flaw-induced reduction in strength<sup>(43, 44)</sup>. Work by **Guazzato et al' 2004**<sup>(6)</sup> showed that sandblasting produced the most effective tetragonal to monoclinic phase change when compared to fine polishing, grinding with an abrasive wheel, or grinding using a diamond bur. It was determined that sandblasting was able to induce transformation at low temperature (room temperature)<sup>(44,45)</sup>. In the literatures, there are a controversial information about the minimum accepted clinical bond strength, while it was mentioned that minimum of 5 MPa set by the International Organization for Standardization<sup>(21)</sup>, Thurmond et al., and Piwowarczyk et al.,<sup>(46,47)</sup> stated that it must not be less than 10-12 MPa to survive in the oral cavity, and of course it varies according to location in the oral cavity and the type of occlusion. However, the bond strength yielded from sand blasting with alumina followed by silan coupling agent, failed to reach the minimum accepted bond strength (10-12Mpa) needed for clinical service in the oral cavity.<sup>(46,47)</sup>

The fourth proposed surface treatment was application of the tribochemical chemistry in coating the zirconia surface with silica modified alumina particles then silanization of the surface before application of the adhesive cement.

Tribochemical method that has shown to be quite effective in increasing bond strength to zirconia based ceramics is the technique of silica coating followed by silane application is a simple and effective technique that uses silica-coated 30mm aluminum trioxide particles, followed by the application of silane. According to the manufacturer, sandblasting with this material uses impact energy to apply a silica coating to the target surface<sup>(48)</sup>. Other literatures denies these claims, as it is unlikely, that in the case of high toughness alumina or zirconia materials, there is actual embedding of silica coated particles because of the intrinsic hardness of the target material.<sup>(49,50)</sup>

Modification of the technique was proposed to enhance the bond strength with cement through increasing the surface roughness of zirconia via homogenization between Alumina particles and Alumina modified Silica particles. In addition, it was reported that conventional blasting procedure, yielded a layer which is loosely attached to the ceramic substrate, therefore bonding to this lose

layer impair formation of a durable zirconia/cement bond strength<sup>(51)</sup>

The EDXS analysis and SEM studies showed that the coating silica on Zirconia surface could be cleaned away by ultrasonic washing in water or pressurized water spray, indicating that no stable chemical bond was formed between silica and zirconia. The silica was probably deposited on the Zirconia surface *via* weak physical force, such as vander- Waals forces, which might not be strong and stable enough in a clinical situation. (**Chen et al., 2011a**), **Nishigawa et al., 2008**;<sup>(49,50)</sup>

The proposed additional steps of immersion in saturated solution of alumina and silica then heat tempering at 100C° was postulated to improve coalescence and bonding between silica and alumina particles and the surface of zirconia. In addition, it is well known that heating the surface increases its surface energy, improves wettability and removes any oily substances or dirt waste coming from handling the samples. Also immersion in the saturated solution of silica and alumina, and subsequent heat treatment may increase the concentration of fresh active elements available for chemical bonding with applied silane and thereafter, the adhesive cement.

Internal research at Bisco Dental Products with tribo-chemical bonding (Cojet/Rocatec) showed that it did not offer improved bonding and could be prone to degradation.<sup>(52)</sup>

It was reported in a previous study conducted by ÖZCAN *et al* (2008)<sup>(51)</sup> that bond strength after tribochemical surface treatment with Rocatec system of Y-ZTP Lava™ samples and thermocycling for 6000 cycle, samples were bonded with Panavia F resin cement, the reported shear bond was 8.23 3.8 MPa with no significant difference between air abrasion with 110µ Al<sub>2</sub>O<sub>3</sub> and Rocatec system.

In this study, the bond strength of group4 samples, has improved and the proposed modified tribochemical method yielded much more stable silica/alumina layer which reflected on the durable bond strength even after aging procedure, taking into consideration that there was a good bond strength to dentin surface interface which was not considered in most of other studies. The surface roughness (12.7±4.2) and bond strength (13.4±4.5) increased significantly and the bond strength exceeded that value set by ISO standards for accepted clinical bond strength<sup>(21)</sup>.

Zirconia is a very tough material and the HF acid etching suitable for application in silicate based ceramics are not suitable to induce etching in surface of Y-ZTP. On the other hand, considering the metallic nature of pure zirconium, it can be predicted that acids or etching solutions originally performed

for conditioning alloys may work well for etching zirconium dioxide crowns or bridge frameworks. A hot chemical solution has been proposed to etch the wings of Maryland bridges, roughening the surface and promoting retention<sup>(53)</sup>.

25% conc. Hydrochloric acid is considered as a corrosive solution for most of alloys and tough material. The addition of ferric chloride to HCl increases its ability to etch the preferential boundaries of the superficial grains of Y-ZTP. Ferric chloride is an octahedral, highly symmetric complex ion. It can form complexes with the weakest metal ions on the surface of the substrate (Y-ZTP). The resultant new complex ions dissolve in water and leads to the observed etching –corrosion procedure. The leaching nature of this solution make it suitable to produce widening between the densely arranged grains of Y-ZTP, created a surface roughness recorded in this study which exceeded all other surface treatments ever described in a relevant literatures ( $54.5 \pm 6.8$ ), after 15 minutes application period. The advantage of this solution is that its evaporation does not significantly vary its composition during use. In addition, the preparation of the solution is not a technique sensitive<sup>(54)</sup>. The action of the hot etching solution is basically a corrosion-controlled process. It selectively etches the zirconia,<sup>(55)</sup> enabling for micro-retentions by modifying the grain boundaries through preferential removal of the less arranged, high energy peripheral atoms the created micro spaces that would optimize the overall bonding mechanism. The shear bond strength results of acid etching group was  $24.2 \pm 3.2$  MPa. The bond strength doubled nearly 8 times. Once resin cement systems penetrate the inter-grain spaces forming micromechanical interlocks with the substrate, a superior strength would be necessary to debond it.

This method of inducing surface roughness had the advantage of removing the inter facial layer (whether Alumina or Silica) and the cement penetrates through the created inter-grains spaces. It is well known that the weakest link in any adhesion process is always the inter mediate layer where cracks and de-bonding may occur<sup>(56)</sup>. So by removing this inherent weak layer, bond strength doubled 8 times.

Acid etching technique was the least sensitive and in-expensive method for functionalizing surface of Y-ZTP dental ceramics, as the modified tribochemical technique proposed in this study has a prolonged time to be performed, and further investigation are needed to reduce the described steps and therefore facilitate its application in dental labs.

More investigations are also needed to find out other more suitable etching solutions, to improve acid etching techniques, and make it more suitable for application in dental clinics at room temperature, instead of being in the labs, as the hot temperature of the etching solution is not applicable in clinics.

#### 5- Conclusions:

1-Although it needed much time to be performed, yet, proposed modified tribochemical technique was a valid method in increasing Y-ZTP /dentin bond strength and recommended to be applied rather than conventional tribochemical method. 2- The use of hot etching solution of HCl and ferric chloride  $FeCl_3$  is recommended as an effective and simple method and could be performed easily in labs to modify surface of zirconia chemically and mechanically, so that, enhance bonding to dentin surface even after water storage and thermo-cycling. 3-Self adhesive cement RelyX Unicem, produced a comparable results to resin cement with the advantage of reduced time and elimination of sensitive steps of resin bonding cements which requires a separate etching and bonding agents.

#### Corresponding author

Manal R. Abu-Eittah  
Fixed Prosthodontics Department, Faculty of Dentistry, Minia University, Minia, Egypt.  
[manalrafei@yahoo.com](mailto:manalrafei@yahoo.com)

#### References:

- 1-Denry I, Kelly JR: State of the art of zirconia for dental applications. *Dent Mater* (2008), 24, 299-307.
- 2- Guazzato M, Albakry M, Ringer SP, Swain MV (2005b). Strength, fracture toughness and microstructure of a selection of all-ceramic materials. Part II. Zirconia-based dental ceramics. *Dental Materials* 20, 449-456.
- 3-Subbarao, EC. Heuer, AH.; Hobbs, LW., Zirconia-an overview. Science and technology of zirconia. Columbus: The American Ceramic Society; 1981. p. 1-24.
4. Goff JP, Hayes W, Hull S, Hutchings MT, Clausen KN. Defect structure of yttria-stabilized zirconia and its influence on the ionic conductivity at elevated temperatures. *Phys Rev B* 1999;59:14202–14219.
- 5-Fu-Kang F, Kuznetsov AK, Keler ÉK (1963). Phase relationships in the system  $Y_2O_3-ZrO_2$  Part 2. solid solution. *Institute of silicate chemistry, Academy of sciences of the USSR* 4, 601-610.
- 6-Guazzato M, Albakry M, Ringer SP & Swain MV (2004) Strength, fracture toughness and

- microstructure of a selection of all-ceramic materials Part II Zirconia-based dental ceramics *Dental Materials* 20(5) 449-456.
- 7-Rieth PH, Reed JS, Naumann AW. Fabrication and flexural strength of ultra-fine grained yttrium-stabilized zirconia. *Bull Am Ceram Soc* 1976; 55:717.
- 8-. Gupta TK, Bechtold JH, Kuznickie RC, Cado LH, Rossing BR. Stabilization of tetragonal phase in polycrystalline zirconia. *J Mater Sci* 1978; 13:1464-1470.
- 9-Yilmaz H, Aydin C & Gul BE (2007) Flexural strength and fracture toughness of dental core ceramics *The Journal of Prosthetic Dentistry* 98(2) 120-128.
- 10-Tinschert J, Zwez D, Marx R, Anusavice KJ (2001) Structural reliability of alumina-, feldspar, leucite-, mica- and zirconia based ceramics. *J Dent* 28:529-535
- 11- Papanagiotou HP, Morgano SM, Giordano RA & Pober R(2006) In vitro evaluation of low temperature aging effects and finishing procedures on the flexural strength and structural stability of Y-TZP dental ceramics, *The Journal of Prosthetic Dentistry* 96(3) 154-164.
- 12- Tinschert J, Natt G, Mautsch W, Augthun M & Spiekermann H (2001) Fracture resistance of lithium disilicate-, alumina-, and zirconia-based three-unit fixed partial dentures: A laboratory study *International Journal of Prosthodontics* 14(3)231-238
- 13-Ahmad Jum'ah. Zirconia all-ceramic restorations: do they perform well? *Smile Dental Journal | Volume 6, Issue 2 – 2011,8-10.*
- 14- Sundh A, Molin M, Sjogren G. Fracture resistance of yttrium oxide partially-stabilized zirconia all-ceramic bridges after veneering and mechanical fatigue testing. *Dent Mater* 2005;21:476-82.
- 15-Kern M, Wegner SM. Bonding to zirconia ceramic: adhesion methods and their durability. *Dent Mater* 1998;14:64-71.
- 16-Spohr AM, Borges GA, Jnior LH, Mota EG, Oshima HM, Spohr AM, et al. Surface modification of in-ceram zirconia ceramic by Nd:YAG laser, Rocatec system, or aluminium oxide sandblasting and its bond strength to a resin cement. *Photomed Laser Surg* 2008;26:203-8.
- 17-Della Bona A, Borba M, Benetti P, Cecchetti D. Effect of surface treatments on the bond strength of a zirconia-reinforced ceramic to composite resin. *Braz Oral Res* 2007;21:10-5.
- 18-Blatz MB, Sadan A, Kern M. Resin-ceramic bonding: A review of the literature. *J Prosthet Dent* 2003;89:268-274. [PubMed: 12644802]
19. Blatz MB, Sadan A, Arch GH, Lang BR. In vitro evaluation of long-term bonding of porcelain all-ceramic alumina restorations with modified resin luting cement. *J Prosthet Dent* 2003;89:381-387.
- 20-. Blatz MB, Chiche G, Holst S, Sadan A. Influence of surface treatment and simulated aging on bond strengths of luting agents to zirconia. *Quintessence Int* 2007;38:745-753.
- 21- Klaus D. Jandt : Atomic force microscopy of biomaterials surfaces and interfaces, *Surface Science* 2001,491,303-332.
- 22-Child TF, van Ooij W. Application of silane technology to prevent corrosion of metals and improve paint adhesion. *Trans Inst Metal Finish* 1999; 77:64-70. <sup>21 results</sup>
- 23- Jeffrey Y., Brian R., Jeffrey R. Piascik, Robert S.: Adhesion/cementation to zirconia and other non-silicate ceramics: Where are we now? *Dent Mater.* 2011 January; 27(1): 71-82.
- 24-Xible AA, de Jesus Tavares R, de Araujo CRP, Bonachela WC. Effect of silica coating and silanization on flexural and composite-resin bond strengths of zirconia posts: An in vitro study. *J Prosthet Dent* 2006; 95:224-229.
- 25-Peumans M, Hikita K, De Munck J, Van Landuyt K, Poitevin A, Lambrechts P, Van Meerbeek B. Effects of ceramic treatments on the bond strength of an adhesive luting agent to cad-cam ceramic. *J Dent Res* 2007; 35:282-288.
- 26-Derand P and Derand T. Bond strength of luting cements to zirconium oxide ceramics. *Int J Prosthodont* 2000; 13: 131-135.
- 27-Kern M and Wegner SM. Bonding to zirconia ceramic: adhesion methods and their durability. *Dent Mater* 1998; 14: 64-71.
- 28-Partima Mishra: Low-Temperature synthesis of alumina from aluminium salt and urea, *Materials Letters* 55(2002) 425-429.
- 29- Bogush G.H., Tracy and C.F. Zukoski IV: preparation of monodisperse silica particles : control of size and mass fabrication; *Journal of non-crystalline solids*, 104,95-106,1988.
- 30- Steven S, Zumdahl : *CHEMISTRY, D.C., Health and Company, Lexington, Toronto, 1986.*
- 31- Jukka P. Matinlinna, Lippo V. Lassila *Bonding to zirconia framework after pretreatment with selected silane monomers, 27 ( 2 0 1 1 ) 273-280*
- 32- Guazzato M, Quach L, Albakry M & Swain MV (2005) Influence of surface and heat treatments

- on the flexural strength of Y-TZP dental ceramic Journal of Dentistry 33(1) 9-18.
- 33- Zhang Y, Lawn BR, Rekow ED & Thompson VP (2004) Effect of sandblasting on the long-term performance of dental ceramics Journal of Biomedical Materials Research Part B: Applied Biomaterials 71(2) 381-386
- 34-Luthy H, Loeffel O & Hammerle CH (2006) Effect of thermo- cycling on bond strength of luting cements to zirconia ceramic Dental Materials 22(2) 195-200.
- 35- ÖZCAN M, Kerkdijk S & Valandro LF (2007) Comparison of resin cement adhesion to Y-TZP ceramic following manufacturers' instructions of the cements only Clinical Oral Investigations 13(3) 279-282.
- 36-Wolfart M, Lehmann F, Wolfart S & Kern M (2007) Durability of the resin bond strength to zirconia ceramic after using different surface conditioning methods Dental Materials 23(1) 45-50
- 37- Mazzitelli C, Monticelli F, Osorio R, Casucci A, Toledano M, Ferrari M. Effect of simulated pulpal pressure on self-adhesive cements bonding to dentin. Dent Mater. 2008;24:1156-63.
- 38- Matinlinna JP, Lassila LV, Ozcan M, Yli-Urpo A, Vallittu PK, An introduction to silanes and their clinical applications in dentistry. Int J. Prosthodont 2004;17:155-164
- 39- Matinlinna JP, Lassila LVJ, Vallittu PK. The effects of a novel silane blend system on resin bond strength to silica-coated ti substrate. J Dent Res 2006; 34:436-443
- 40- Yoshida K, Tsuo Y, Atsuta M. Bonding of dual-cured resin cement to zirconia ceramic using phosphate acid ester monomer and zirconate coupler. J Biomed Mat Res B Appl Biomater 2006; 77B:28-33
- 41- Yang B, Lange-Jansen HC, Scharnberg M, Wolfart S, Ludwig K, Adelung R, et al. (2008). Influence of saliva contamination on zirconia ceramic bonding. Dent Mater 24(4):508-13.
- 42-Yang B, Scharnberg M, Wolfart S, Quaas AC, Ludwig K, Adelung R, et al. (2007). Influence of contamination on bonding to zirconia ceramic. J Biomed Mater Res B Appl Biomater 81(2):283- 90.
- 43-Kosmac T, Oblak C, Jevnikar P, Funduk N, Marion L. The effect of surface grinding and sandblasting on flexural strength and reliability of y-tpz zirconia ceramic. Dent Mater 1999;15:426-433.
- 44- Kosmac T, Oblak C, Jevnikar P, Funduk N, Marion L. Strength and reliability of surface treated ytzp dental ceramics. J Biomed Mater Res B Appl Biomater 2000;53:304-313
- 45-Atsu SS, Lilicarlan MA, Kucukesmen HC, Aka PS. Effect of zirconium-oxide ceramic surface treatments on the bond strength to adhesive resin. J Prosthet Dent 2006;95:430-436.
- 46- Thurmond J, Barkmeier W, Wildweding M. Effect of porcelain surface treatments on bond strength of composite resin bonded to porcelain. J Prosthet Dent 1994; 72: 355-359.
- 47-Piwowarczyk A, Lauer HC, Sorensen JA. The shear bond strength between luting cements and zirconia ceramics after two pre-treatments. Oper Dent 2005;30:382-388.
- 48- Bouschlicher MR, Reinhardt JW, vargas MA. Surface treatment techniques for resin composite repair. Am J Dent.1997;10:279-283
- 49- Chen, L., B.I. Suh, J. Kim and F.R. Tay, 2011a. Evaluation of silica-coating techniques for Zirconia bonding. Am. J. Dent., 24: 79-84.
- 50- Nishigawa, G., Y. Maruo, M. Irie, M. Oka and K. Yoshihara *et al.*, 2008. Ultrasonic cleaning of silica-coated zirconia influences bond strength between zirconia and resin luting material. Dent. Mater. J., 27: 842-848.
- 51- ÖZCAN Mutlu, Henk NIJHUIS and Luiz Felipe VALANDRO: Effect of Various Surface Conditioning Methods on the Adhesion of Dual-cure Resin Cement with MDP Functional Monomer to Zirconia after Thermal Aging; Dental Materials Journal 27(1) 99 104, 2008
- 52- Jack Griffin Jr, Byoung Suh, and Liang Chen; SURFACE TREATMENTS FOR ZIRCONIA BONDING: A CLINICAL PERSPECTIVE. Canadian Journal of Restorative Dentistry and Prosthodontics, 23-29. 2010.
- 53- Ferrari M, Cagidiaco MC, Borracchini A, Bertelli E. Evaluation of a chemical etching solution for nickel-chromium-beryllium and chromium-cobalt alloys. Journal of Prosthetic Dentistry 1989; 62:516-21.
- 54- George F. Vander Voort: Metallography: Principles and Practice, ASM International, www.asminternational.org. 1984.
- 55- Javid AH, Hassani AH, and Golshan G. Selective removal of heavy metals from ferric chloride caused by etching processes by using sulfide precipitation. Journal of Environmental Science & Technology, Spring 2004, No. 20.
- 56- Perez F., M. Morency, Bissonnette B., and L. Courard : Correlation between the roughness of the substrate surface and the debonding risk, Concrete Repair, Rehabilitation and Retrofitting II - Alexander et al (eds) 949-956. © 2009 Taylor & Francis Group, London.

**Time-dependent two-dimensional Zakharov-Kuznetsov equation in the electron-positron-ion plasmas**Ali H. Bhrawy<sup>1,2</sup> A.S. Alofi<sup>1</sup> and M.A. Abdelkawy<sup>2</sup><sup>1</sup> Department of Mathematics, Faculty of Science, King Abdulaziz University, Jeddah, Saudi Arabia<sup>2</sup> Department of Mathematics, Faculty of Science, Beni-Suef University, Beni-Suef, Egypt  
(Bhrawy) [alibhrawy@yahoo.co.uk](mailto:alibhrawy@yahoo.co.uk), (Alofi) [asmo1427@yahoo.com](mailto:asmo1427@yahoo.com), (Abdelkawy) [melkawy@yahoo.com](mailto:melkawy@yahoo.com)

**Abstract:** The electrons and positrons are assumed to be dynamic, whereas positively charged ions are considered stationary. Using a computerized symbolic computation technique, we obtained several solutions of the Zakharov-Kuznetsov equation which describes the propagation of the electrostatic excitations in the electron-positron-ion plasmas. These solutions contain hyperbolic, triangular solutions. These solutions extended to ion-acoustic waves in quantum dusty plasmas consisting of electrons, ions, and negatively/positively charged dust particles. In addition, as an illustrative sample, the properties of the solutions of this equation are shown with some figures.

[Bhrawy AH, Alofi AS, Abdelkawy AM. **Time-dependent two-dimensional Zakharov-Kuznetsov equation in the electron-positron-ion plasmas.** *Life Sci J* 2012;9(4):1804-1813] (ISSN:1097-8135).  
<http://www.lifesciencesite.com>. 274

**Keywords:** Extended F-expansion (EFE) method; Nonlinear partial differential equations; Nonlinear physical phenomena; Zakharov-Kuznetsov equation; Electron-positron (EP) plasma.

**1. Introduction**

Electron-positron (EP) plasma is a new state of matter with unique thermodynamic properties which different from those of ordinary electron-ion plasmas [1]. The study of electron-positron-ion (e-p-i) plasmas is important to understand the behavior of both astrophysical and laboratory plasmas. Electron-positron plasmas have been observed in the polar regions of neutron stars [2], active galactic nuclei [3], in magnetospheres of pulsars [4], polar regions of neutron stars [2], intense laser fields [5] and tokamak plasmas [6]-[7]. During the last few years, there have great interest in the field of pair (electron-positron) plasma, which is composed of electrons and positrons, having equal mass but having opposite charge [8]-[11].

The nonlinear wave phenomena can be observed in various scientific fields, such as plasma physics, optical fibers, fluid dynamics, chemical physics, etc. The nonlinear wave phenomena can be obtained in solutions of nonlinear evolution equations (NEEs). The exact solutions of these NEEs plays an important role in the understanding of nonlinear phenomena. In the past decades, many methods were developed for finding exact solutions of NEEs [12]-[20].

Although Porubov et al. [21]-[22] have obtained some exact periodic solutions to some nonlinear wave equations, they use the Weierstrass elliptic function and involve complicated deducing. A Jacobi elliptic function (JEF) expansion method, which is straightforward and effective, was proposed for constructing periodic wave solutions for some nonlinear evolution equations. The essential idea of this method is similar to the tanh method by replacing

the tanh function with some JEFs such as  $sn$ ,  $cn$  and  $dn$ . For example, the Jacobi periodic solution in terms of  $sn$  may be obtained by applying the  $sn$ -function expansion. Many similarly repetitious calculations have to be done to search for the Jacobi doubly periodic wave solutions in terms of  $cn$  and  $dn$  [23].

Recently F-expansion method [24]-[27] was proposed to obtain periodic wave solutions of NLEEs, which can be thought of as a concentration of JEF expansion since F here stands for everyone of JEFs. In this paper, we apply the extended F-expansion (EFE) method with symbolic computation to system (4) for constructing their interesting Jacobi doubly periodic wave solutions. It is shown that soliton solutions and triangular periodic solutions can be established as the limits of Jacobi doubly periodic wave solutions. In addition the algorithm that we use here also a computerized method, in which generating an algebraic system.

**2. Material and Methods****Governing equations**

The dynamics of the electrostatic (ES) solitons in the electron-positron-ion plasmas is governed by [28]

$$\frac{\partial n_{\pm}}{\partial T} + \nabla \cdot (n_{\pm} u_{\pm}) = 0, \quad \nabla \equiv \hat{X} \frac{\partial}{\partial X} + \hat{Y} \frac{\partial}{\partial Y} \quad (1)$$

$$m \left( \frac{\partial u_{\pm}}{\partial t} + u_{\pm} \cdot \nabla u_{\pm} \right) = \mp e \nabla \phi - \frac{1}{n_{\pm}} \nabla p_{\pm} \pm \frac{e}{c} (u_{\pm} \times B_0 \hat{X}) + 2m (u_{\pm} \times \Omega_0 \hat{X}), \quad (2)$$



and Poisson's equation

$$\nabla^2 \phi = 4\pi(n_- - n_+ - s_3 z_3 n_3), \tag{3}$$

where  $(X, Y)$ ,  $n_{\pm}$ ,  $u_{\pm}$ ,  $\phi$ ,  $n_3$ ,  $e$ ,  $c$ ,  $B_0$ ,  $\Omega_0$ ,  $p_{\pm}$ ,  $m$ ,  $z_3$  and  $s_3 = \pm 1$  are the coordinate of the propagation plane; the number densities of the positron, electron; the fluid velocity variables of the positron and electron; the ES potential; the number densities of ion; the magnitude of the electron charge; the speed of light; the magnitude of the ambient magnetic field; the rotation frequency; the pressures of the positron and electron; the electron mass; the ion charge number and the ion charge sign respectively.

The time-dependent two-dimensional ZK equation can be obtained from Eqs. (1)-(3), using multi-dimensional reductive technique [29] and the independent variables [30]

$$x = \varepsilon^{1/2}(X - \lambda T), \quad y = \varepsilon^{1/2}Y, \quad t = \varepsilon^{3/2}T,$$

where  $\varepsilon$  is a small parameter and  $\lambda(\lambda > 0)$  is the phase velocity as

$$v_x + \delta v_{xx} + \mu v_{xxx} + \nu_{xyy} = 0, \tag{4}$$

where  $v$  is the 1<sup>st</sup>-order ES potential perturbation of the ES potential  $\phi$ . Eq. (4) describe many physical phenomena, such as the weakly nonlinear ion-acoustic waves in a strongly magnetized lossless plasma comprised of the cold ions and hot isothermal electrons, the nonlinear dust-acoustic waves in a magnetized three-component dusty plasma consisting of negatively charged dust-particles and nonlinear ion-acoustic waves in a quantum magneto plasma.

**Extended F-expansion method**

In this section, we introduce a simple description of the EFE method, for a given partial differential equation

$$G(u, u_x, u_y, u_z, u_t, u_{xy}, \dots) = 0. \tag{5}$$

We like to know whether travelling waves (or stationary waves) are solutions of Eq. (5). The first step is to unite the independent variables  $x$ ,  $y$ ,  $z$  and  $t$  into one particular variable through the new variable

$$\zeta = \alpha x + \beta y + \gamma z + \nu t, \quad u(x, y, t) = U(\zeta),$$

where  $\nu$  is wave speed, and reduce Eq. (5) to an ordinary differential equation(ODE)

$$G(U, U', U'', U''', \dots) = 0. \tag{6}$$

Our main goal is to derive exact or at least approximate solutions, if possible, for this ODE. For

(2) this purpose, let us simply  $U$  as the expansion in the form,

$$u(x, y, z, t) = U(\zeta) = \sum_{i=0}^N a_i F^i + \sum_{i=1}^N a_{-i} F^{-i}, \tag{7}$$

where

$$F' = \sqrt{A + BF^2 + CF^4}, \tag{8}$$

the highest degree of  $\frac{d^p U}{d\zeta^p}$  is taken as

$$O\left(\frac{d^p U}{d\zeta^p}\right) = N + p, \quad p = 1, 2, 3, \dots, \tag{9}$$

$$O(U^q \frac{d^p U}{d\zeta^p}) = (q+1)N + p, \quad q = 0, 1, 2, \dots, p = 1, 2, 3, \dots, \tag{10}$$

where  $A$ ,  $B$  and  $C$  are constants, and  $N$  in Eq. (6) is a positive integer that can be determined by balancing the nonlinear term(s) and the highest order derivatives. Normally  $N$  is a positive integer, so that an analytic solution in closed form may be obtained. Substituting Eqs. (5)- (8) into Eq. (6) and comparing the coefficients of each power of  $F(\zeta)$  in both sides, to get an over-determined system of nonlinear algebraic equations with respect to  $\nu$ ,  $a_0$ ,  $a_1$ ,  $\dots$ . Solving the over-determined system of nonlinear algebraic equations by use of Mathematica. The relations between values of  $A$ ,  $B$ ,  $C$  and corresponding JEF solution  $F(\zeta)$  of Eq. (7) are given in table 1. Substitute the values of  $A$ ,  $B$ ,  $C$  and the corresponding JEF solution  $F(\zeta)$  chosen from table 1 into the general form of solution, then an ideal periodic wave solution expressed by JEF can be obtained.

**Table 1:** Relation between values of  $(A, B, C)$  and corresponding  $F$

$A$	$B$	$C$	$F(\zeta)$
1	$-1 - m^2$	$m^2$	$\text{sn}(\zeta),$ $\text{cd}(\zeta) = \frac{\text{cn}(\zeta)}{\text{dn}(\zeta)}$
$1 - m^2$	$2m^2 - 1$	$-m^2$	$\text{cn}(\zeta)$
$m^2 - 1$	$2 - m^2$	-1	$\text{dn}(\zeta)$
$m^2$	$-1 - m^2$	1	$\text{ns}(\zeta) = \frac{1}{\text{sn}(\zeta)},$ $\text{dc}(\zeta) = \frac{\text{dn}(\zeta)}{\text{cn}(\zeta)}$
$-m^2$	$2m^2 - 1$	$1 - m^2$	$\text{nc}(\zeta) = \frac{1}{\text{cn}(\zeta)}$
-1	$2 - m^2$	$m^2 - 1$	$\text{nd}(\zeta) = \frac{1}{\text{dn}(\zeta)}$

1	$2-m^2$	$1-m^2$	$sc(\zeta) = \frac{sn(\zeta)}{cn(\zeta)}$
1	$2m^2-1$	$\frac{m^2}{(1+m^2)}$	$sd(\zeta) = \frac{sn(\zeta)}{dn(\zeta)}$
$1-m^2$	$2-m^2$	1	$cs(\zeta) = \frac{cn(\zeta)}{sn(\zeta)}$
$\frac{-m^2}{(1-m^2)}$	$2m^2-1$	1	$ds(\zeta) = \frac{dn(\zeta)}{sn(\zeta)}$
$\frac{1}{4}$	$\frac{1-2m^2}{2}$	$\frac{1}{4}$	$ns(\zeta) + cs(\zeta)$
$\frac{1-m^2}{4}$	$\frac{1+m^2}{2}$	$\frac{1-m^2}{2}$	$nc(\zeta) + sc(\zeta)$
$\frac{1}{4}$	$\frac{m^2-2}{2}$	$\frac{m^2}{4}$	$ns(\zeta) + ds(\zeta)$
$\frac{m^2}{4}$	$\frac{m^2-2}{2}$	$\frac{m^2}{4}$	$sn(\zeta) + ics(\zeta)$

where  $sn(\zeta)$ ,  $cn(\zeta)$  and  $dn(\zeta)$  are the JE sine function, JE cosine function and the JEF of the third kind, respectively. And  $cn^2(\zeta) = 1 - sn^2(\zeta)$ ,  $dn^2(\zeta) = 1 - m^2 sn^2(\zeta)$ , (11) with the modulus  $m$  ( $0 < m < 1$ ).

When  $m \rightarrow 1$ , the Jacobi functions degenerate to the hyperbolic functions, i.e.,  $sn\zeta \rightarrow \tanh\zeta$ ,  $cn\zeta \rightarrow \text{sech}\zeta$ ,  $dn\zeta \rightarrow \text{sech}\zeta$ , when  $m \rightarrow 0$ , the Jacobi functions degenerate to the triangular functions, i.e.,

$$sn\zeta \rightarrow \sin\zeta, \quad cn\zeta \rightarrow \cos\zeta \quad \text{and} \quad dn \rightarrow 1.$$

### 3. Results

In this section, we will apply the extended method to study the time-dependent two-dimensional ZK equation (4)

$$v_t + \delta v v_x + \mu v_{xxx} + \gamma v_{xyy} = 0, \tag{12}$$

if we use  $\zeta = \alpha x + \beta y + vt$ ,  $\phi(x, y, t) = V(\zeta)$  carries PDE (12) into the ODE

$$vV' + \alpha\delta VV' + \alpha(\beta^2\gamma + \alpha^2\mu)V''' = 0, \tag{13}$$

where by integrating once we obtain, upon setting the constant of integration to zero,

$$2vV + \alpha\delta V^2 + 2\alpha(\beta^2\gamma + \alpha^2\mu)V'' = 0, \tag{14}$$

Balancing the term  $V''$  with the term  $V^2$  we obtain  $N=2$  then

$$U(\zeta) = a_0 + a_1 F + a_{-1} F^{-1} + a_2 F^2 + a_{-2} F^{-2}, \tag{15}$$

$$F' = \sqrt{A + BF^2 + CF^4}.$$

Substituting Eq. (15) into Eq. (14) and comparing the coefficients of each power of  $F$  in both sides, to get an over-determined system of nonlinear algebraic equations with respect to  $v$ ,  $a_i$ ,  $i = 1, -1, -2, 2$ . Solving the over-determined system of nonlinear algebraic equations by use of Mathematica, we obtain three groups of constants:

- $$a_{-1} = a_{-2} = 0, \quad a_0 = -\frac{4(\alpha^2\mu + \beta^2\gamma)(B \pm \sqrt{B^2 + 12AC})}{\delta},$$

$$a_2 = -\frac{12C(\alpha^2\mu + \beta^2\gamma)}{\delta}, \quad a_{-2} = -\frac{12A(\alpha^2\mu + \beta^2\gamma)}{\delta},$$

$$v = \pm 4\alpha(\alpha^2\mu + \beta^2\gamma)\sqrt{B^2 + 12AC}, \tag{16}$$

- $$a_{-1} = a_{-2} = a_2 = 0, \quad a_0 = -\frac{4(\alpha^2\mu + \beta^2\gamma)(B \pm \sqrt{B^2 - 3AC})}{\delta},$$

$$a_{-2} = -\frac{12A(\alpha^2\mu + \beta^2\gamma)}{\delta}, \quad v = \pm 4\alpha(\alpha^2\mu + \beta^2\gamma)\sqrt{B^2 - 3AC}, \tag{17}$$

- $$a_{-1} = a_{-2} = a_2 = 0, \quad a_0 = -\frac{4(\alpha^2\mu + \beta^2\gamma)(B \pm \sqrt{B^2 - 3AC})}{\delta}, \tag{18}$$

$$a_{-2} = -\frac{12C(\alpha^2\mu + \beta^2\gamma)}{\delta}, \quad v = \pm 4\alpha(\alpha^2\mu + \beta^2\gamma)\sqrt{B^2 - 3AC},$$

if we use Eqs. (16)-(18) we obtained the 1<sup>st</sup>-order ES potential perturbation of the ES potential of Eq. (12) as:-

$$v_1 = \frac{4(\alpha^2\mu + \beta^2\gamma)(1+m^2 \pm \sqrt{12m^2 + (1+m^2)^2})}{\delta} - \frac{12(\alpha^2\mu + \beta^2\gamma)}{\delta}$$

$$\times [m^2 sn^2(\alpha x + \beta y \pm 4(\alpha^2\mu + \beta^2\gamma)\sqrt{(12m^2 + (1+m^2)^2}t)) + ns^2(\alpha x + \beta y \pm 4(\alpha^2\mu + \beta^2\gamma)\sqrt{12m^2 + (1+m^2)^2}t)], \tag{19}$$

$$v_2 = \frac{4(\alpha^2\mu + \beta^2\gamma)(1+m^2 \pm \sqrt{12m^2 + (1+m^2)^2})}{\delta} - \frac{12(\alpha^2\mu + \beta^2\gamma)}{\delta}$$

$$\times [m^2 cd^2(\alpha x + \beta y \pm 4(\alpha^2\mu + \beta^2\gamma)\sqrt{12m^2 + (1+m^2)^2}t) + d^2(\alpha x + \beta y \pm 4(\alpha^2\mu + \beta^2\gamma)\sqrt{12m^2 + (1+m^2)^2}t)], \tag{20}$$

$$v_3 = -\frac{4(\alpha^2\mu + \beta^2\gamma)(2m^2 - 1) \pm \sqrt{12m^2(m^2 - 1) + (1 - 2m^2)^2}}{\delta}$$

$$+ \frac{12(\alpha^2\mu + \beta^2\gamma)}{\delta} [m^2 cn^2(\alpha x + \beta y \pm 4(\alpha^2\mu + \beta^2\gamma)\sqrt{12m^2(m^2 - 1) + (1 - 2m^2)^2}t) + (1 - m^2)nc^2(\alpha x + \beta y \pm 4(\alpha^2\mu + \beta^2\gamma)\sqrt{12m^2(m^2 - 1) + (1 - 2m^2)^2}t)], \tag{21}$$

$$v_4 = \frac{4(\alpha^2\mu + \beta^2\gamma)((2-m^2) \pm \sqrt{(2-m^2)^2 - 12(m^2-1)})}{\delta} + \frac{12(\alpha^2\mu + \beta^2\gamma)}{\delta} [dn^2(\alpha x + \beta y \pm 4(\alpha^2\mu + \beta^2\gamma)) \sqrt{(2-m^2)^2 - 12(m^2-1)} + (1-m^2)nd^2(\alpha x + \beta y \pm 4(\alpha^2\mu + \beta^2\gamma))\sqrt{(2-m^2)^2 - 12(m^2-1)}], \quad (22)$$

$$v_5 = \frac{4(\alpha^2\mu + \beta^2\gamma)(2-m^2 \pm \sqrt{12(1-m^2) + (2-m^2)^2})}{\delta} - \frac{12(\alpha^2\mu + \beta^2\gamma)}{\delta} [(1-m^2)sc^2(\alpha x + \beta y \pm 4(\alpha^2\mu + \beta^2\gamma)) \times \sqrt{12(1-m^2) + (2-m^2)^2} + cs^2(\alpha x + \beta y \pm 4(\alpha^2\mu + \beta^2\gamma))\sqrt{12(1-m^2) + (2-m^2)^2}], \quad (23)$$

$$v_6 = \frac{4(\alpha^2\mu + \beta^2\gamma)(2m^2 - 1 \pm \sqrt{12m^2(1+m^2) + (1-2m^2)^2})}{\delta} - \frac{12(\alpha^2\mu + \beta^2\gamma)}{\delta} [m^2(1+m^2)sd^2(\alpha x + \beta y \pm 4(\alpha^2\mu + \beta^2\gamma)) \times \sqrt{12m^2(1+m^2) + (1-2m^2)^2} + ds^2(\alpha x + \beta y \pm 4(\alpha^2\mu + \beta^2\gamma))\sqrt{12m^2(1+m^2) + (1-2m^2)^2}], \quad (24)$$

$$v_7 = \frac{4(\alpha^2\mu + \beta^2\gamma)(0.5 - m^2 \pm \sqrt{0.75 + (0.5 - m^2)^2})}{\delta} - \frac{3(\alpha^2\mu + \beta^2\gamma)}{\delta} [(ns(\alpha x + \beta y \pm 4(\alpha^2\mu + \beta^2\gamma)) \sqrt{0.75 + (0.5 - m^2)^2} + cs(\alpha x + \beta y \pm 4(\alpha^2\mu + \beta^2\gamma))\sqrt{0.75 + (0.5 - m^2)^2} + (ns(\alpha x + \beta y \pm 4(\alpha^2\mu + \beta^2\gamma))\sqrt{0.75 + (0.5 - m^2)^2} + cs(\alpha x + \beta y \pm 4(\alpha^2\mu + \beta^2\gamma))\sqrt{0.75 + (0.5 - m^2)^2})^{-2}], \quad (25)$$

$$v_8 = \frac{4(\alpha^2\mu + \beta^2\gamma)}{\delta} \times \frac{(0.5 + 0.5m^2 \pm \sqrt{12(0.5 - 0.5m^2)(0.25 - 0.25m^2) + (0.5 + 0.5m^2)^2})}{\delta} - \frac{12(\alpha^2\mu + \beta^2\gamma)}{\delta} [(0.5 - 0.5m^2) \times (nc(\alpha x + \beta y \pm 4(\alpha^2\mu + \beta^2\gamma)) \sqrt{12(0.5 - 0.5m^2)(0.25 - 0.25m^2) + (0.5 + 0.5m^2)^2} + sc(\alpha x + \beta y \pm 4(\alpha^2\mu + \beta^2\gamma)) \sqrt{12(0.5 - 0.5m^2)(0.25 - 0.25m^2) + (0.5 + 0.5m^2)^2})^2 + (0.25 - 0.25m^2)(nc(\alpha x + \beta y \pm 4(\alpha^2\mu + \beta^2\gamma)) \sqrt{12(0.5 - 0.5m^2)(0.25 - 0.25m^2) + (0.5 + 0.5m^2)^2} + sc(\alpha x + \beta y \pm 4(\alpha^2\mu + \beta^2\gamma)) \sqrt{12(0.5 - 0.5m^2)(0.25 - 0.25m^2) + (0.5 + 0.5m^2)^2})^{-2}], \quad (26)$$

$$v_9 = \frac{4(\alpha^2\mu + \beta^2\gamma)(0.5m^2 - 1 \pm \sqrt{0.75m^2 + (-1 + 0.5m^2)^2})}{\delta} - \frac{3(\alpha^2\mu + \beta^2\gamma)}{\delta} [m^2(ns(\alpha x + \beta y \pm 4(\alpha^2\mu + \beta^2\gamma)) \sqrt{0.75m^2 + (-1 + 0.5m^2)^2} + ds(\alpha x + \beta y \pm 4(\alpha^2\mu + \beta^2\gamma))\sqrt{0.75m^2 + (-1 + 0.5m^2)^2})^2 + (ns(\alpha x + \beta y \pm 4(\alpha^2\mu + \beta^2\gamma))\sqrt{0.75m^2 + (-1 + 0.5m^2)^2} + ds(\alpha x + \beta y \pm 4(\alpha^2\mu + \beta^2\gamma))\sqrt{0.75m^2 + (-1 + 0.5m^2)^2})^{-2}], \quad (27)$$

$$v_{10} = \frac{4(\alpha^2\mu + \beta^2\gamma)(0.5m^2 - 1 \pm \sqrt{0.75m^4 + (-1 + 0.5m^2)^2})}{\delta} - \frac{3(\alpha^2\mu + \beta^2\gamma)}{\delta} [m^2(sn(\alpha x + \beta y \pm 4(\alpha^2\mu + \beta^2\gamma)) \sqrt{0.75m^4 + (-1 + 0.5m^2)^2} + ics(\alpha x + \beta y \pm 4(\alpha^2\mu + \beta^2\gamma))\sqrt{0.75m^4 + (-1 + 0.5m^2)^2})^2 + (sn(\alpha x + \beta y \pm 4(\alpha^2\mu + \beta^2\gamma))\sqrt{0.75m^4 + (-1 + 0.5m^2)^2} + ics(\alpha x + \beta y \pm 4(\alpha^2\mu + \beta^2\gamma))\sqrt{0.75m^4 + (-1 + 0.5m^2)^2})^{-2}], \quad (28)$$

$$v_{11} = \frac{4(\alpha^2\mu + \beta^2\gamma)(1 + m^2 \pm \sqrt{(1+m^2)^2 - 3m^2})}{\delta} - \frac{12(\alpha^2\mu + \beta^2\gamma)}{\delta} [m^2sn^2(\alpha x + \beta y \pm 4(\alpha^2\mu + \beta^2\gamma))\sqrt{(1+m^2)^2 - 3m^2}], \quad (29)$$

$$v_{12} = \frac{4(\alpha^2\mu + \beta^2\gamma)(1 + m^2 \pm \sqrt{(1+m^2)^2 - 3m^2})}{\delta} - \frac{12(\alpha^2\mu + \beta^2\gamma)}{\delta} [m^2cd^2(\alpha x + \beta y \pm 4(\alpha^2\mu + \beta^2\gamma))\sqrt{(1+m^2)^2 - 3m^2}], \quad (30)$$

$$v_{13} = \frac{4(\alpha^2\mu + \beta^2\gamma)(2m^2 - 1 \pm \sqrt{3m^2(1-m^2) + (1-2m^2)^2})}{\delta} + \frac{12(\alpha^2\mu + \beta^2\gamma)}{\delta} [m^2cn^2(\alpha x + \beta y \pm 4(\alpha^2\mu + \beta^2\gamma)) \times \sqrt{3m^2(1-m^2) + (1-2m^2)^2}], \quad (31)$$

$$v_{14} = \frac{4(\alpha^2\mu + \beta^2\gamma)(2-m^2 \pm \sqrt{(2-m^2)^2 - 3(1-m^2)})}{\delta} + \frac{12(\alpha^2\mu + \beta^2\gamma)}{\delta} [dn^2(\alpha x + \beta y \pm 4(\alpha^2\mu + \beta^2\gamma)) \times \sqrt{(2-m^2)^2 - 3(1-m^2)}], \quad (32)$$

$$v_{15} = \frac{4(\alpha^2\mu + \beta^2\gamma)(2-m^2 \pm \sqrt{3(m^2-1) + (2-m^2)^2})}{\delta} - \frac{12(\alpha^2\mu + \beta^2\gamma)}{\delta} [(1-m^2)sc^2(\alpha x + \beta y \pm 4(\alpha^2\mu + \beta^2\gamma)) \times \sqrt{3(m^2-1) + (2-m^2)^2}], \quad (33)$$

$$v_{16} = \frac{4(\alpha^2\mu + \beta^2\gamma)(2m^2 - 1(\alpha^2\mu + \beta^2\gamma) \pm \sqrt{(1-2m^2)^2 - 3m^2(1+m^2)})}{\delta} \\ - \frac{12(\alpha^2\mu + \beta^2\gamma)}{\delta} [m^2(1+m^2)sd^2(\alpha\gamma + \beta\gamma \pm 4(\alpha^2\mu + \beta^2\gamma)) \\ \times \sqrt{(1-2m^2)^2 - 3m^2(1+m^2)t}], \quad (34)$$

$$v_{17} = \frac{4(\alpha^2\mu + \beta^2\gamma)(0.5nt \pm \sqrt{(0.5-m^2)^2 - \frac{3}{16}})}{\delta} \\ - \frac{3(\alpha^2\mu + \beta^2\gamma)}{\delta} [(ns(\alpha\gamma + \beta\gamma \pm 4(\alpha^2\mu + \beta^2\gamma))\sqrt{(0.5-m^2)^2 - \frac{3}{16}} \\ + cs(\alpha\gamma + \beta\gamma \pm 4(\alpha^2\mu + \beta^2\gamma))\sqrt{((0.5-m^2)^2 - \frac{3}{16})t}], \quad (35)$$

$$v_{18} = \frac{4(\alpha^2\mu + \beta^2\gamma)}{\delta} \\ \times \frac{(0.5 + 0.5m^2 \pm \sqrt{3(0.5m^2 - 0.5)(0.25 - 0.25m^2) + (0.5 + 0.5m^2)^2})}{\delta} \\ - \frac{12(\alpha^2\mu + \beta^2\gamma)}{\delta} [(0.5 - 0.5m^2)(nc(\alpha\gamma + \beta\gamma \pm 4(\alpha^2\mu + \beta^2\gamma)) \\ \times \sqrt{3(0.5m^2 - 0.5)(0.25 - 0.25m^2) + (0.5 + 0.5m^2)^2} \\ + sc(\alpha\gamma + \beta\gamma \pm 4(\alpha^2\mu + \beta^2\gamma)) \\ \times \sqrt{3(0.5m^2 - 0.5)(0.25 - 0.25m^2) + (0.5 + 0.5m^2)^2}t)], \quad (36)$$

$$v_{19} = \frac{4(\alpha^2\mu + \beta^2\gamma)(0.5m^2 - 1 \pm \sqrt{((1-0.5m^2)^2 - \frac{3m^2}{16}})}{\delta} \\ - \frac{3(\alpha^2\mu + \beta^2\gamma)}{\delta} [m^2(ns(\alpha\gamma + \beta\gamma \pm 4(\alpha^2\mu + \beta^2\gamma))\sqrt{(1-0.5m^2)^2 - \frac{3m^2}{16}} \\ + ds(\alpha\gamma + \beta\gamma \pm 4(\alpha^2\mu + \beta^2\gamma))\sqrt{(1-0.5m^2)^2 - \frac{3m^2}{16}}t)], \quad (37)$$

$$v_{20} = \frac{4(\alpha^2\mu + \beta^2\gamma)(0.5m^2 - 1 \pm \sqrt{(1-0.5m^2)^2 - \frac{3m^4}{16}})}{\delta} \\ - \frac{3(\alpha^2\mu + \beta^2\gamma)}{\delta} [m^2(sn(\alpha\gamma + \beta\gamma \pm 4(\alpha^2\mu + \beta^2\gamma)) \\ \sqrt{(1-0.5m^2)^2 - \frac{3m^4}{16}} \\ + ics(\alpha\gamma + \beta\gamma \pm 4(\alpha^2\mu + \beta^2\gamma))\sqrt{(1-0.5m^2)^2 - \frac{3m^4}{16}}t)], \quad (38)$$

$$v_{21} = \frac{4(\alpha^2\mu + \beta^2\gamma)(1+m^2 \pm \sqrt{(1+m^2)^2 - 3m^2})}{\delta} \\ - \frac{12(\alpha^2\mu + \beta^2\gamma)}{\delta} [ns^2(\alpha\gamma + \beta\gamma \pm 4(\alpha^2\mu + \beta^2\gamma))\sqrt{(1+m^2)^2 - 3m^2}t)], \quad (39)$$

$$v_{22} = \frac{4(\alpha^2\mu + \beta^2\gamma)(1+m^2 \pm \sqrt{(1+m^2)^2 - 3m^2})}{\delta} \\ - \frac{12(\alpha^2\mu + \beta^2\gamma)}{\delta} [dc^2(\alpha\gamma + \beta\gamma \pm 4(\alpha^2\mu + \beta^2\gamma))\sqrt{((1+m^2)^2 - 3m^2)t}], \quad (40)$$

$$v_{23} = \frac{4(\alpha^2\mu + \beta^2\gamma)(2m^2 - 1 \pm \sqrt{3m^2(1-m^2) + (1-2m^2)^2})}{\delta} \\ - (1-m^2)nc^2(\alpha\gamma + \beta\gamma \pm 4(\alpha^2\mu + \beta^2\gamma))\sqrt{3m^2(1-m^2) + (1-2m^2)^2}t)], \quad (41)$$

$$v_{24} = \frac{4(\alpha^2\mu + \beta^2\gamma)(2-m^2 \pm \sqrt{(2-m^2)^2 - 3(1-m^2)})}{\delta} \\ + \frac{12(\alpha^2\mu + \beta^2\gamma)}{\delta} [(1-m^2)nd^2(\alpha\gamma + \beta\gamma \pm 4(\alpha^2\mu + \beta^2\gamma)) \\ \times \sqrt{(2-m^2)^2 - 3(1-m^2)t)], \quad (42)$$

$$v_{25} = \frac{4(\alpha^2\mu + \beta^2\gamma)(2-m^2 \pm \sqrt{3(m^2-1) + (2-m^2)^2})}{\delta} \\ - \frac{12(\alpha^2\mu + \beta^2\gamma)}{\delta} [cs^2(\alpha\gamma + \beta\gamma \pm 4(\alpha^2\mu + \beta^2\gamma))\sqrt{3(m^2-1) + (2-m^2)^2}t)], \quad (43)$$

$$v_{26} = \frac{4(\alpha^2\mu + \beta^2\gamma)(2m^2 - 1 \pm \sqrt{(1-2m^2)^2 - 3m^2(1+m^2)})}{\delta} \\ - \frac{12(\alpha^2\mu + \beta^2\gamma)}{\delta} [ds^2(\alpha\gamma + \beta\gamma \pm 4(\alpha^2\mu + \beta^2\gamma)) \\ \times \sqrt{(1-2m^2)^2 - 3m^2(1+m^2)t)], \quad (44)$$

$$v_{27} = \frac{4(\alpha^2\mu + \beta^2\gamma)(0.5-m^2 \pm \sqrt{(0.5-m^2)^2 - \frac{3}{16}})}{\delta} \\ - \frac{3(\alpha^2\mu + \beta^2\gamma)}{\delta} [(ns(\alpha\gamma + \beta\gamma \pm 4(\alpha^2\mu + \beta^2\gamma))\sqrt{(0.5-m^2)^2 - \frac{3}{16}} \\ + cs(\alpha\gamma + \beta\gamma \pm 4(\alpha^2\mu + \beta^2\gamma))\sqrt{(0.5-m^2)^2 - \frac{3}{16}}t)], \quad (45)$$

$$v_{28} = \frac{4(\alpha^2\mu + \beta^2\gamma)}{\delta} \\ \times \frac{(0.5 + 0.5m^2 \pm \sqrt{3(0.5m^2 - 0.5)(0.25 - 0.25m^2) + (0.5 + 0.5m^2)^2})}{\delta} \\ - \frac{12(0.25 - 0.25m^2)(\alpha^2\mu + \beta^2\gamma)}{\delta} (nc(\alpha\gamma + \beta\gamma \pm 4(\alpha^2\mu + \beta^2\gamma)) \\ \times \sqrt{3(0.5m^2 - 0.5)(0.25 - 0.25m^2) + (0.5 + 0.5m^2)^2}t \\ + sc(\alpha\gamma + \beta\gamma \pm 4(\alpha^2\mu + \beta^2\gamma)) \\ \times \sqrt{3(0.5m^2 - 0.5)(0.25 - 0.25m^2) + (0.5 + 0.5m^2)^2}t)^{-2}, \quad (46)$$

$$v_{29} = -\frac{4(\alpha^2\mu + \beta^2\gamma)(0.5m^2 - 1 \pm \sqrt{(1-0.5m^2)^2 - \frac{3m^2}{16}})}{\delta} - \frac{3(\alpha^2\mu + \beta^2\gamma)}{\delta} [(ns(ax + \beta y \pm 4(\alpha^2\mu + \beta^2\gamma) \sqrt{(1-0.5m^2)^2 - \frac{3m^2}{16}} - t) + ds(ax + \beta y \pm 4(\alpha^2\mu + \beta^2\gamma) \sqrt{(1-0.5m^2)^2 - \frac{3m^2}{16}} - t))^{-2}], \tag{47}$$

$$v_{30} = -\frac{4(\alpha^2\mu + \beta^2\gamma)(0.5m^2 - 1 \pm \sqrt{(1-0.5m^2)^2 - \frac{3m^4}{16}})}{\delta} - \frac{3(\alpha^2\mu + \beta^2\gamma)}{\delta} [(sn(ax + \beta y \pm 4(\alpha^2\mu + \beta^2\gamma) \sqrt{(1-0.5m^2)^2 - \frac{3m^4}{16}} - t) + ics(ax + \beta y \pm 4(\alpha^2\mu + \beta^2\gamma) \sqrt{(1-0.5m^2)^2 - \frac{3m^4}{16}} - t))^{-2}]. \tag{48}$$

The modulus of electrostatic potentials  $\phi_1$ ,  $\phi_2$ ,  $\phi_3$  and  $\phi_4$  are displayed in figures 1, 2, 3 and 4 respectively, with values of parameters listed in their captions.

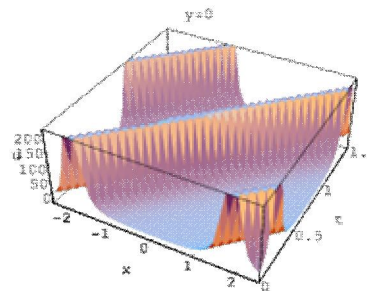

Fig. 2 (b)

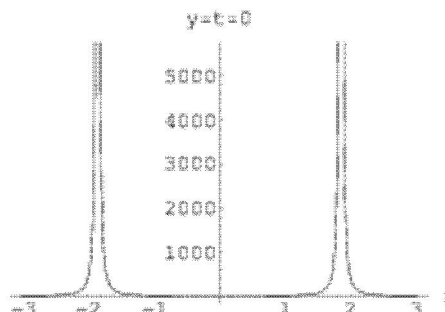

Fig. 2 The modulus of solitary wave solution  $\phi_2$  (Eq. 20) where  $\alpha = \beta = \varepsilon = \gamma = \lambda = m = \delta = 0.5$ .

Fig. 1 (a)

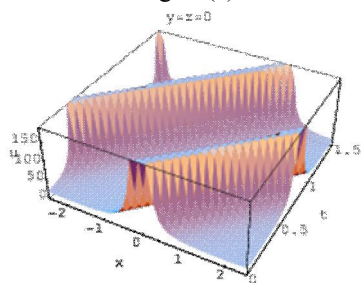

Fig. 1 (b)

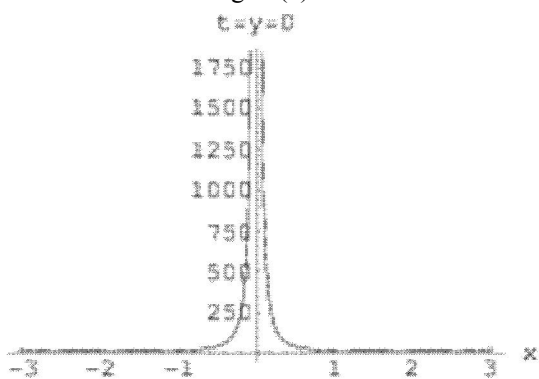

Fig. 1 The modulus of solitary wave solution  $\phi_1$  (Eq. 19) where  $\alpha = \beta = \varepsilon = \gamma = \lambda = m = \delta = 0.5$ .

Fig. 2 (a)

Fig. 3 (a)

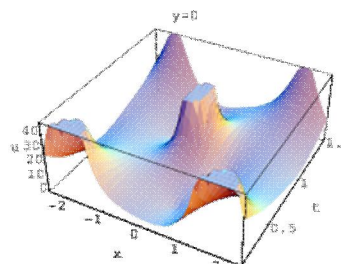

Fig. 3 (b)

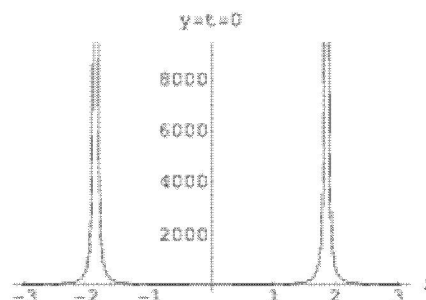

Fig. 3 The modulus of solitary wave solution  $\phi_3$  (Eq. 21) where  $\alpha = \beta = \varepsilon = \gamma = \lambda = m = \delta = 0.5$ .

Fig. 4 (a)

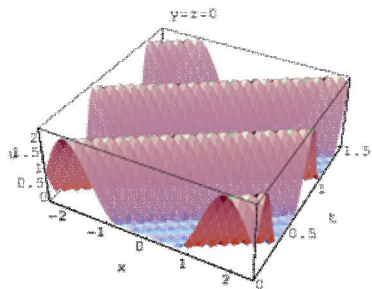

Fig. 4 (b)

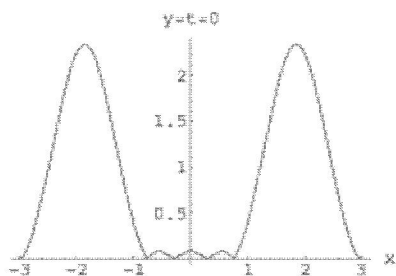

Fig. 4 The modulus of solitary wave solution  $\phi_4$  (Eq. 22) where  $\alpha = \beta = \varepsilon = \gamma = \lambda = m = \delta = 0.5$ .

**3.1 Soliton solutions**

Some solitary wave solutions can be obtained, if the modulus  $m$  approaches to 1 in Eqs. (19)-(48)

$$v_{31} = \frac{4(\alpha^2\mu + \beta^2\gamma)(2 \pm 4)}{\delta} - \frac{12(\alpha^2\mu + \beta^2\gamma)}{\delta} [\tanh^2(\alpha x + \beta y \pm 16(\alpha^2\mu + \beta^2\gamma)t) + \coth^2(\alpha x + \beta y \pm 16(\alpha^2\mu + \beta^2\gamma)t)], \tag{49}$$

$$v_{32} = -\frac{4(\alpha^2\mu + \beta^2\gamma)(1 \pm 1)}{\delta} + \frac{12(\alpha^2\mu + \beta^2\gamma)}{\delta} [\operatorname{sech}^2(\alpha x + \beta y \pm 4(\alpha^2\mu + \beta^2\gamma)t)], \tag{50}$$

$$v_{33} = -\frac{4(\alpha^2\mu + \beta^2\gamma)(1 \pm 1)}{\delta} - \frac{12(\alpha^2\mu + \beta^2\gamma)}{\delta} [\operatorname{csch}^2(\alpha x + \beta y \pm 4(\alpha^2\mu + \beta^2\gamma)t)], \tag{51}$$

$$v_{34} = -\frac{4(\alpha^2\mu + \beta^2\gamma)(1 \pm 5)}{\delta} - \frac{12(\alpha^2\mu + \beta^2\gamma)}{\delta} [2\sinh^2(\alpha x + \beta y \pm 20(\alpha^2\mu + \beta^2\gamma)t) + \operatorname{csch}^2(\alpha x + \beta y \pm 20(\alpha^2\mu + \beta^2\gamma)t)], \tag{52}$$

$$v_{35} = -\frac{4(\alpha^2\mu + \beta^2\gamma)(-0.5 \pm 1)}{\delta} - \frac{3(\alpha^2\mu + \beta^2\gamma)}{\delta} \times [(\coth(\alpha x + \beta y \pm 4(\alpha^2\mu + \beta^2\gamma)t) + \operatorname{csch}(\alpha x + \beta y \pm 4(\alpha^2\mu + \beta^2\gamma)t))^2 + (\coth(\alpha x + \beta y \pm 4(\alpha^2\mu + \beta^2\gamma)t) + \operatorname{csch}(\alpha x + \beta y \pm 4(\alpha^2\mu + \beta^2\gamma)t))^{-2}], \tag{53}$$

$$v_{36} = -\frac{4(\alpha^2\mu + \beta^2\gamma)(-0.5 \pm 1)}{\delta} - \frac{3(\alpha^2\mu + \beta^2\gamma)}{\delta} \times [(\tanh(\alpha x + \beta y \pm 4(\alpha^2\mu + \beta^2\gamma)t) + i\operatorname{csch}(\alpha x + \beta y \pm 4(\alpha^2\mu + \beta^2\gamma)t))^2 + (\tanh(\alpha x + \beta y \pm 4(\alpha^2\mu + \beta^2\gamma)t) + i\operatorname{csch}(\alpha x + \beta y \pm 4(\alpha^2\mu + \beta^2\gamma)t))^{-2}], \tag{54}$$

$$v_{37} = \frac{4(\alpha^2\mu + \beta^2\gamma)(2 \pm 1)}{\delta} - \frac{12(\alpha^2\mu + \beta^2\gamma)}{\delta} [\tanh^2(\alpha x + \beta y \pm 4(\alpha^2\mu + \beta^2\gamma)t)], \tag{55}$$

$$v_{38} = -\frac{4(\alpha^2\mu + \beta^2\gamma)(1 \pm 1)}{\delta} + \frac{12(\alpha^2\mu + \beta^2\gamma)}{\delta} [\operatorname{sech}^2(\alpha x + \beta y \pm 4(\alpha^2\mu + \beta^2\gamma)t)], \tag{56}$$

$$v_{39} = -\frac{4(\alpha^2\mu + \beta^2\gamma)(1 \pm i\sqrt{5})}{\delta} - \frac{24(\alpha^2\mu + \beta^2\gamma)}{\delta} \times [\sinh^2(\alpha x + \beta y \pm 4i(\alpha^2\mu + \beta^2\gamma)\sqrt{5}t)], \tag{57}$$

$$v_{40} = -\frac{(\alpha^2\mu + \beta^2\gamma)(-2 \pm 1)}{\delta} - \frac{3(\alpha^2\mu + \beta^2\gamma)}{\delta} \times [(\coth(\alpha x + \beta y \pm (\alpha^2\mu + \beta^2\gamma)t) + \operatorname{csch}(\alpha x + \beta y \pm (\alpha^2\mu + \beta^2\gamma)t))^2], \tag{58}$$

$$v_{41} = -\frac{(\alpha^2\mu + \beta^2\gamma)(-2 \pm 1)}{\delta} - \frac{3(\alpha^2\mu + \beta^2\gamma)}{\delta} \times [(\tanh(\alpha x + \beta y \pm (\alpha^2\mu + \beta^2\gamma)t) + i\operatorname{csch}(\alpha x + \beta y \pm (\alpha^2\mu + \beta^2\gamma)t))^2], \tag{59}$$

$$v_{42} = \frac{4(\alpha^2\mu + \beta^2\gamma)(2 \pm 1)}{\delta} - \frac{12(\alpha^2\mu + \beta^2\gamma)}{\delta} [\coth^2(\alpha x + \beta y \pm 4(\alpha^2\mu + \beta^2\gamma)t)], \tag{60}$$

$$v_{43} = \frac{4(\alpha^2\mu + \beta^2\gamma)(1 \pm i\sqrt{5})}{\delta} - \frac{12(\alpha^2\mu + \beta^2\gamma)}{\delta} \\ [csch^2(\alpha x + \beta y \pm 4i(\alpha^2\mu + \beta^2\gamma)\sqrt{5}t)], \quad (61)$$

$$v_{44} = -\frac{(\alpha^2\mu + \beta^2\gamma)(-2 \pm 1)}{\delta} - \frac{3(\alpha^2\mu + \beta^2\gamma)}{\delta} \\ \times [(\coth(\alpha x + \beta y \pm (\alpha^2\mu + \beta^2\gamma)t) \\ + csch(\alpha x + \beta y \pm (\alpha^2\mu + \beta^2\gamma)t))^{-2}], \quad (62)$$

$$v_{45} = -\frac{(\alpha^2\mu + \beta^2\gamma)(-2 \pm 1)}{\delta} - \frac{3(\alpha^2\mu + \beta^2\gamma)}{\delta} \\ \times [(\tanh(\alpha x + \beta y \pm (\alpha^2\mu + \beta^2\gamma)t) \\ + icsch(\alpha x + \beta y \pm (\alpha^2\mu + \beta^2\gamma)t))^{-2}], \quad (63)$$

### 3.2 Triangular periodic solutions

Some trigonometric function solutions can be obtained, if the modulus  $m$  approaches to zero in Eqs. (19)-(48)

$$v_{46} = \frac{4(\alpha^2\mu + \beta^2\gamma)(1 \pm 1)}{\delta} - \frac{12(\alpha^2\mu + \beta^2\gamma)}{\delta} \\ [csc^2(\alpha x + \beta y \pm 4(\alpha^2\mu + \beta^2\gamma)t)], \quad (64)$$

$$v_{47} = \frac{4(\alpha^2\mu + \beta^2\gamma)(1 \pm 1)}{\delta} - \frac{12(\alpha^2\mu + \beta^2\gamma)}{\delta} \\ [sec^2(\alpha x + \beta y \pm 4(\alpha^2\mu + \beta^2\gamma)t)], \quad (65)$$

$$v_{48} = -\frac{4(\alpha^2\mu + \beta^2\gamma)(2 \pm 4)}{\delta} - \frac{12(\alpha^2\mu + \beta^2\gamma)}{\delta} \\ [\tan^2(\alpha x + \beta y \pm 16(\alpha^2\mu + \beta^2\gamma)t) \\ + \cot^2(\alpha x + \beta y \pm 16(\alpha^2\mu + \beta^2\gamma)t)], \quad (66)$$

$$v_{49} = -\frac{4(\alpha^2\mu + \beta^2\gamma)(0.5 \pm)}{\delta} - \frac{3(\alpha^2\mu + \beta^2\gamma)}{\delta} \\ \times [(\csc(\alpha x + \beta y \pm 4(\alpha^2\mu + \beta^2\gamma)t) \\ + \cot(\alpha x + \beta y \pm 4(\alpha^2\mu + \beta^2\gamma)t))^2 \\ + (\csc(\alpha x + \beta y \pm 4(\alpha^2\mu + \beta^2\gamma)t) \\ + \cot(\alpha x + \beta y \pm 4(\alpha^2\mu + \beta^2\gamma)t))^{-2}], \quad (67)$$

$$v_{50} = -\frac{2(\alpha^2\mu + \beta^2\gamma)(1 \pm \sqrt{7})}{\delta} - \frac{12(\alpha^2\mu + \beta^2\gamma)}{\delta} \\ \times [0.5(\sec(\alpha x + \beta y \pm 2(\alpha^2\mu + \beta^2\gamma)\sqrt{7}t) \\ + \tan(\alpha x + \beta y \pm 2(\alpha^2\mu + \beta^2\gamma)\sqrt{7}t))^2 \\ + 0.25(\sec(\alpha x + \beta y \pm 2(\alpha^2\mu + \beta^2\gamma)\sqrt{7}t) \\ + \tan(\alpha x + \beta y \pm 2(\alpha^2\mu + \beta^2\gamma)\sqrt{7}t))^{-2}], \quad (68)$$

$$v_{51} = -\frac{4(\alpha^2\mu + \beta^2\gamma)(1 \pm 1)}{\delta} - \frac{3(\alpha^2\mu + \beta^2\gamma)}{\delta} \\ [\sin^2(\alpha x + \beta y \pm 4(\alpha^2\mu + \beta^2\gamma)t)], \quad (69)$$

$$v_{52} = -\frac{4(\alpha^2\mu + \beta^2\gamma)(1 \pm 1)}{\delta} - \frac{3(\alpha^2\mu + \beta^2\gamma)}{\delta} \\ \times [(\sin(\alpha x + \beta y \pm 4(\alpha^2\mu + \beta^2\gamma)t) \\ + i \cot(\alpha x + \beta y \pm 4(\alpha^2\mu + \beta^2\gamma)t))^{-2}], \quad (70)$$

$$v_{53} = -\frac{4(\alpha^2\mu + \beta^2\gamma)(2 \pm 1)}{\delta} - \frac{12(\alpha^2\mu + \beta^2\gamma)}{\delta} \\ [\tan^2(\alpha x + \beta y \pm 4(\alpha^2\mu + \beta^2\gamma)t)], \quad (71)$$

$$v_{54} = -\frac{2(\alpha^2\mu + \beta^2\gamma)(1 \pm 1)}{\delta} - \frac{3(\alpha^2\mu + \beta^2\gamma)}{\delta} \\ \times [(\csc(\alpha x + \beta y \pm 2(\alpha^2\mu + \beta^2\gamma)t) \\ + \cot(\alpha x + \beta y \pm 2(\alpha^2\mu + \beta^2\gamma)t))^2], \quad (72)$$

$$v_{55} = -\frac{(\alpha^2\mu + \beta^2\gamma)(2 \pm i\sqrt{2})}{\delta} - \frac{6(\alpha^2\mu + \beta^2\gamma)}{\delta} \\ \times (\sec(\alpha x + \beta y \pm i(\alpha^2\mu + \beta^2\gamma)\sqrt{2}t) \\ + \tan(\alpha x + \beta y \pm i(\alpha^2\mu + \beta^2\gamma)\sqrt{2}t))^2, \quad (73)$$

$$v_{56} = \frac{4(\alpha^2\mu + \beta^2\gamma)(2 \pm 1)}{\delta} - \frac{12(\alpha^2\mu + \beta^2\gamma)}{\delta} [\cot^2(\alpha x + \beta y \pm 4(\alpha^2\mu + \beta^2\gamma)t)], \quad (74)$$

$$v_{57} = \frac{2(\alpha^2\mu + \beta^2\gamma)(1 \pm 1)}{\delta} - \frac{3(\alpha^2\mu + \beta^2\gamma)}{\delta} \times [(\csc(\alpha x + \beta y \pm 2(\alpha^2\mu + \beta^2\gamma)t) + \cot(\alpha x + \beta y \pm 2(\alpha^2\mu + \beta^2\gamma)t))^{-2}], \quad (75)$$

$$v_{58} = \frac{(\alpha^2\mu + \beta^2\gamma)(2 \pm i\sqrt{2})}{\delta} - \frac{12(0.25 - 0.25m^2)(\alpha^2\mu + \beta^2\gamma)}{\delta} \times (\sec(\alpha x + \beta y \pm i(\alpha^2\mu + \beta^2\gamma)\sqrt{2}t) + \tan(\alpha x + \beta y \pm i(\alpha^2\mu + \beta^2\gamma)\sqrt{2}t))^{-2}, \quad (76)$$

$$v_{59} = \frac{4(0.25 - 0.25m^2)(1 \pm 1)}{\delta} - \frac{3(\alpha^2\mu + \beta^2\gamma)}{\delta} \times (\sin(\alpha x + \beta y \pm 4(\alpha^2\mu + \beta^2\gamma)t) + i \cot(\alpha x + \beta y \pm 4(\alpha^2\mu + \beta^2\gamma)t))^{-2}. \quad (77)$$

#### 4. Discussions

By introducing appropriate transformations and using extended F-expansion method, we have been able to obtain in a unified way with the aid of symbolic computation system-mathematica, a series of solutions including single and the combined Jacobi elliptic function. Also, extended F-expansion method is shown that soliton solutions and triangular periodic solutions can be established as the limits of Jacobi doubly periodic wave solutions. When  $m \rightarrow 1$ , the Jacobi functions degenerate to the hyperbolic functions and given the solutions by the extended hyperbolic functions methods. When  $m \rightarrow 0$ , the Jacobi functions degenerate to the triangular functions and given the solutions by extended triangular functions methods.

#### Acknowledgements:

This article was funded by the Deanship of Scientific Research (DSR), King Abdulaziz University, Jeddah. The authors, therefore, acknowledge with thanks DSR technical and financial support.

#### Corresponding Author:

Ali H. Bhrawy Department of Mathematics, Faculty of Science, King Abdulaziz University, Jeddah, Saudi Arabia, [alibhrawy@yahoo.co.uk](mailto:alibhrawy@yahoo.co.uk)

#### References

1. Shah A, Saeed R. Ion acoustic shock waves in a relativistic electron-positron-ion plasmas, *Physics Letters A* 373 (2009) 4164-4168.
2. Michel FC. *Theory of Neutron Star Magnetosphere*, Chicago University Press, Chicago, 1991
3. Miller HR, Witta PJ. *Active Galactic Nuclei*, Springer-Verlag, Berlin, 1987, p. 202.
4. Michel FC. *Theory of Pulsar Magnetospheres*, *Rev. Mod. Phys.* 54 (1982) 1-66.
5. Berezhiani V, Tskhakaya DD, Shukla PK. Pair production in a strong wake field driven by an intense short laser pulse, *Phys. Rev. A* 46 (1992) 6608-6612.
6. Greaves RG, Tinkle MD, Surko CM. Creation and uses of positron plasmas, *Phys. Plasmas* 1 (1994) 1439 8pp.
7. Helander P, Ward DJ. Positron Creation and Annihilation in Tokamak Plasmas with Runaway Electrons, *Phys. Rev. Lett.* 90 (2003) 135004 4pp.
8. El-Shamy EF, El-Bedwehy NA. On the linear and nonlinear characteristics of electrostatic solitary waves propagating in magnetized electron-positron-ion plasmas, *Physics Letters A* 374 (2010) 4425-4429.
9. Kourakis I, Verheest F, Cramer N. Nonlinear perpendicular propagation of ordinary mode electromagnetic wave packets in pair plasmas and electron-positron-ion plasmas, *Phys. Plasmas* 14 (2007) 022306 10pp.
10. Sahu B, Roychoudhury R, Quantum ion acoustic shock waves in planar and nonplanar geometry, *Phys. Plasmas* 14 (2007) 072310.
11. Shkula PK, Mamun AA, Stenflo L. Vortices in a strongly magnetized electron-positron-ion plasma, *Phys. Scr.* 68 (2003) 295-298.
12. Baldock RA, Robson BA, Barrett RF, Application of an inverse-scattering method to determine the effective interaction between composite particles, *Nuclear Physics A*, 366 (2) (1981) 270-280.
13. Abdelkawy MA, Alghamdi MA, Bhrawy AH. Jacobi doubly periodic wave solutions for three versions of Benjamin-Bona-Mahony equation, *Scientific Research and Essays Vol. 7* (27), (2012) pp. 2417-2423
14. Bhrawy AH, Tharwat MM, Yildirim A, Abdelkawy MA. A Jacobi elliptic function method for nonlinear arrays of vortices, *Indian J*



- Phys, In press (2012) DOI 10.1007/s12648-012-0173-4
15. Bhrawy AH, Abdelkawy MA, Biswas A. Cnoidal and Snoidal Wave Solutions to Coupled Nonlinear Wave Equations by the Extended Jacobi's Elliptic Function Method, Communications in Nonlinear Science and Numerical Simulation, In press (2012) <http://dx.doi.org/10.1016/j.cnsns.2012.08.034>
  16. Johnpillai AG, Yildirim A, Biswas A. Chiral solitons with Bohm potential by Lie group analysis and traveling wave hypothesis, Romanian Journal of Physics, Volume 57, Numbers 3-4, 545-554. (2012).
  17. Kohl R, Biswas A, Milovic D, Zerrad E. Optical soliton perturbation in a non-Kerr law media, Optics and Laser Technology, Volume 40, Issue 4, 647-662. (2008).
  18. Crutcher S, Oseo A, Yildirim A, Biswas A. Oscillatory parabolic law spatial optical solitons. Journal of Optoelectronics and Advanced Materials, Volume 14, Numbers 1-2, 29-40. (2012).
  19. Ebadi G, Kara AH, Petkovic MD, Yildirim A, Biswas A. Solitons and conserved quantities of the Ito equation. Proceedings of the Romanian Academy, Series A. Volume 13, Number 3, 215-224. (2012).
  20. Khater AH, Callebaut DK, Bhrawy AH, Abdelkawy MA. Nonlinear periodic solutions for isothermal magnetostatic atmospheres, Journal of Computational and Applied Mathematics, (2012) 10.1016/j.cam.2012.10.012
  21. Porubov AV. Periodical solution to the nonlinear dissipative equation for surface waves in a convecting liquid layer, Phys. Lett. A. 221 (1996) 391-394.
  22. Porubov AV, Velarde MG. Exact periodic solutions of the complex Ginzburg- Landau equation, J. Math. Phys. 40 (1999) 884-896.
  23. E. Fan , Multiple travelling wave solutions of nonlinear evolution equations using a unified algebraic method, J. Phys. A: Math. Gen. 35 (2002) 6853-6872.
  24. Abdou MA. An improved generalized F-expansion method and its applications, Journal of Computational and Applied Mathematics, 214(1) (2008) 202-208
  25. Bhrawy AH, Alhuthali MSh, Abdelkawy MA. New solutions for (1+1)-dimensional and (2+1)-dimensional Ito equations, Mathematical problems in engineering, (2012) In press
  26. Bhrawy AH, Obaid M. New exact solutions for the Zhiber-Shabat equation using the extended F-expansion method. Life Sci J 2012;9(4):1154-1162
  27. Wang M, Li X. Extended F-expansion method and periodic wave solutions for the generalized Zakharov equations, Physics Letters A, 343(1-3) (2005) 48-54
  28. Kourakis I, Moslem WM, Abdelsalam UM, Sabry R, Shukla PK. Nonlinear dynamics of rotating multi-component pair plasmas and e-p-i plasmas, Plasma Fusion Res. 4 (2009) 1-11.
  29. Washimi H, Taniuti T, Propagation of ion-acoustic solitary waves of small amplitude, Phys. Rev. Lett. 17 (1966) 996-998.
  30. Awawdeh F, New exact solitary wave solutions of the Zakharov-Kuznetsov equation in the electron-positron-ion plasmas, Applied Mathematics and Computation 218 (2012) 7139-7143.

9/6/2012

**Effect of some agricultural treatments on *Beta vulgaris* L. cv. Pleno root**Sakr, M. M.<sup>1,2</sup>, O. A. Almaghrabi<sup>1</sup> and S. M. H. Gowayed<sup>1,2</sup><sup>1</sup> Biology Department, Faculty of Science, North Jeddah, King Abdul-Aziz University, KSA<sup>2</sup> Botany Department, Faculty of Agriculture, Suez Canal University, 41522 Ismailia, Egypt.[salahgowed@yahoo.com](mailto:salahgowed@yahoo.com)

**Abstract:** This research was carried out to study the effect of three sowing dates (15<sup>th</sup> Oct., 15<sup>th</sup> Nov. and 15<sup>th</sup> Dec.) and two cooling treatments (5° C and -20° C) on growth, structure and some chemical components of *B. vulgaris* L. cv. Pleno root. The obtained data are summarize as follows: maximum values of root length, root diameter, fresh and dry weight, cortex thickness, average rows number of cortex, cambium region thickness, sucrose %, T.S.S. and total phenols were recorded with 15<sup>th</sup> Oct. treatment. On the other hand, most of the studied cooling treatments, in most cases, increased of root diameter, fresh and dry weight, total phenols and auxin like-substances in comparison with the control.

[Sakr, M. M., O. A. Almaghrabi and S. M. H. Gowayed. **Effect of some agricultural treatments on *Beta vulgaris* L. cv. Pleno root.** *Life Sci J* 2012;9(4):1814-1819] (ISSN:1097-8135). <http://www.lifesciencesite.com>. 275

**Keywords:** Sugar beet; sowing dates; vernalization; root anatomy; chemical components.

**1. Introduction**

Both sugar beet (*Beta vulgaris* L., Chenopodiaceae) and sugar cane constitute the only important sources of sucrose; nearly 40 % of world sugar production is obtained from sugar beet. Sucrose sugar has been a valued component of human diet for thousands of years. Sugar beet is an important crop in north Egypt Delta because of its tolerance to salinity. Planting data effect of growth, yield and quality of sugar beet under the environment conditions of Egypt, there is a general agreement that early planting of sugar beet produced the highest sucrose percentage as well as root and sugar yield per unit area (Badawi *et al.*, 1995 and Ramadan and Hassanin, 1999). Other studies found that planting sugar beet during October markedly increased diameter, length and weight of roots, sugar content as well as root and sugar yield, compared with the late sowing of November (El-Kassaby and Leilah, 1992, Leilah and Nasr, 1992, Bugbee, 1993, Badawi *et al.*, 1995 and Ozturk *et al.*, 2008). In the same time, Hassan *et al.* (2008) studied the effect of three different sowing dates (15<sup>th</sup> Oct., 15<sup>th</sup> Nov. and 15<sup>th</sup> Dec.) and two vernalization treatments (5° C and -20° C) on growth, structure and some chemical components of *Beta vulgaris* L. cv. Univers root under Ismailia Governorate conditions, and found that the highest values of the root length, root diameter, root fresh, dry weights, cortex thickness, rows number of cortex, cortex cell thickness, rows number of cambium, cambium thickness, cambium cell thickness, total phenols, auxin like substances, % sucrose and T.S.S. were observed with 15 Oct. treatment. Furthermore, most of the studied cooling treatments increased of the periderm thickness, cortex thickness, number of cortex rows, cortex cell thickness, number of cambium rows,

cambium region thickness, total phenols, reducing sugars and non reducing sugars.

Exposure of seeds in many plant species to a prolonged period of cold before the sowing promotes flowering. This process termed vernalization (Reeves *et al.*, 2007).

The aim of present work is to study the effect of sowing dates and vernalization treatments on root growth parameters, root anatomy and some chemical components of *B. vulgaris* L. cv. Pleno root under Ismailia governorate conditions.

**2- Material and Methods:**

Two field experiments were carried out at the Experimental Farm of Suez Canal University, Ismailia Governorate, Egypt. The following treatments were used:-

- a- Sowing on 15<sup>th</sup> October for seeds which cooled at 5° C for 30 days.
- b- Sowing on 15<sup>th</sup> October for seeds which cooled at -20° C for 30 days.
- c- Sowing on 15<sup>th</sup> November for seeds which cooled at 5° C for 30 days.
- d- Sowing on 15<sup>th</sup> November for seeds which cooled at -20° C for 30 days.
- e- Sowing on 15<sup>th</sup> December for seeds which cooled at 5° C for 30 days.
- f- Sowing on 15<sup>th</sup> December for seeds which cooled at -20° C for 30 days.

In addition the control treatments during 2009/2010 and 2010/2011 growing seasons were cultivated. The experiments were designed in randomized split-plot arrangement with three replicates for multigerm *Beta vulgaris* L. cv. Pleno. The seeds were obtained from Sugar Institute Research, Agricultural Center Research, Ministry of

Agriculture, Giza, Egypt. Nitrogen, phosphorous and potassium fertilization were incorporated in soil at the rate of 60, 15 and 50 unit/feddin, respectively. The following parameters were calculated:-

#### **Growth parameters:**

Random samples of five plants were taken from each sub plot at 90, 120, 150 and 180 days after sowing to determine root length (cm), root diameter (cm), fresh weight of root (gm) and dry weight of root (gm).

#### **Root anatomy:**

For studying the characters of transverse sections of the root to describe, periderm thickness (mm), cortex thickness (mm), average rows number of cortex, average cortex cell thickness (mm), average rows number of cambium region, thickness of cambium region (mm) and average thickness of cambium (mm). Killing and fixation in 50 % F.A.A. solution, dehydration and clearing in pure paraffin wax (M.P. 56°C) were carried out as described by Willey (1971). Using a rotary microtome, sections (10  $\mu$ ) were obtained and stained with Safranin and Light green.

#### **Chemical analysis of root:**

For determination, total sugars, total phenols and auxin like-substances, root samples were taken at 90, 120, 150 and 180 days from each treatment and extracted as described by Abdel-Rahman *et al.*, (1975). Total phenols determined using a modified Folin-Ciocalteu method described by William *et al.*, (1965), in addition, auxin like-substances determined according to the method of Gordon and Weber (1951) with a slight modification of the Ehrlich reagents (Fliossion, 1969). Total sugars were determined by anthrone method according to Sadasivam and Manickam (1991). T.S.S. was determined in the root juice using a hand refractometer (Anon., 1990).

The data were subjected to One-way analysis of variance (ANOVA) one using Costat Version 6.311 (CoHort soft- ware, Berkeley, CA 94701) according to Steel and Torrie (1980) with probability  $\leq 0.05$ .

### **3- Results and Discussion:**

#### **Growth parameters:-**

Data in (Table 1) indicate that most of the studied growth parameters (root length, root diameter, fresh weight and dry weight) were very high under 15 Oct. treatment in the two studied seasons except, root length, root fresh weight and root dry weight in the 2009/2010 and 2010/2011 seasons at 90 days from sowing, 150 days from sowing and 120 days from sowing under 15 Nov. treatment, respectively. Moreover, minimum values of the all above mentioned growth parameters were found at 15 Dec. treatment in the two studied seasons. Such results

were obtained by Karbalei *et al.* (2012) who pointed out that sowing dates affected on root size.

Generally, most of the studied cooling treatments decreased of the root length; in the same time, most of the root length was insignificant over the cooling treatments in comparison with control. In addition, in most cases, root diameter, fresh and dry weight was increased significantly as a result of cooling treatments than the control. Such results are in agreement with the data which obtained by El-Kassaby and Leilah (1992), Leilah and Nasr (1992), Bugbee (1993), Badawi *et al.* (1995), Ozturk *et al.* (2008) and Hassan *et al.* (2008).

#### **Root anatomy:-**

Table 2 and Figure 1 show that the highest values of periderm, average rows number of cambium region and average thickness of cambium were observed with 15 Dec. treatment. In addition, maximum values of cortex thickness, average rows number of cortex and cambium region thickness were shown at 15 Oct. treatment. On the other hand, the lowest ones of periderm, cortex thickness, cortex cell thickness, average rows number of cambium region and cambium region thickness were noticed at 15 Nov. treatment.

Data in (Table 2) shows that generally, most of the cooling treatments decreased of the most different tissues of root especially under 5 and -20° C at 15 Dec. treatments in comparison with the control. These results are in agreement with Hassan *et al.* (2008) who showed that sowing dates and cooling treatments affected on various tissues of *B. vulgais* cv. Univers root.

#### **Chemical analysis:-**

##### **Total sugars:**

Table 3 and Figure 2 shows that the maximum values of total sugars were observed with 15 Nov. treatment after 90 and 120 days from sowing and 15 Dec. treatment after 150 and 180 days from the sowing. While, the minimum values of the total sugars were noticed at 15 Oct. treatment after 90 days from sowing, 15 Nov. treatment after 120 days and 15 Oct. treatment after 150 and 180 days from the sowing.

Data in (Table 3 and Figure 2) point out that most of the cooling treatments decreased of total sugars in comparison with control.

##### **Sucrose and total soluble solids (T.S.S.):**

From (Table 3 and Figure 2) indicate that the highest values of sucrose % and T.S.S. at 180 days from the sowing were observed by 15 Oct. and 15 Dec. treatments, respectively. Moreover, the minimal ones were recorded at 15 Nov. and 15 Oct. treatments respectively. Most of the cooling treatments decreased

of sucrose % at 180 days from the sowing except, 5°C and -20° C treatments at 15 Nov. In addition T.S.S. were increased under all -20° C treatments and decreased under all 5° C treatments in comparison

with the control. These results are in accordance with the data which obtained by Refay (2010) who revealed that T.S.S. %, total sugars and sucrose percent were affected by planting dates.

**Table (1):** Effect of the sowing dates and vernalization treatments on root growth of *B. vulgaris* cv. Pleno during the two growing seasons 2009/2010 and 2010/2011.

Sowing dates	Vernalization treatments	Root length (cm)								Root diameter (cm)							
		90 days		120 days		150 days		180 days		90 days		120 days		150 days		180 days	
		2009/10	2010/11	2009/10	2010/11	2009/10	2010/11	2009/10	2010/11	2009/10	2010/11	2009/10	2010/11	2009/10	2010/11	2009/10	2010/11
15 Oct.	Control	20.7	21.7	28.7	33	38.9	40	36	36	13.4	14.7	25	26	29	28	35	36
	5°C	20.4	22	25.4	27	38.4	39	32	31	13.2	14.7	19.3	19.3	30	31	36	36.3
	-20°C	22.5	24	28	23.3	32	32	38	39	13	11.3	22	23.7	27	27.3	36	37
15 Nov.	Control	20.9	23	23.7	22.7	23.4	22	27.2	21.3	10.5	8.3	19.3	18.7	22.8	24.3	28.7	30
	5°C	21.9	25	22.7	24	27	26	29.2	32	10.7	12.3	22.3	21.3	22.5	24	29	31
	-20°C	19.5	16	22	22	25.3	23.3	29	27	9.3	9.7	23	24	19.3	21.3	30.2	33
15 Dec.	Control	19.0	18.3	20.3	21.3	23.3	24.7	21	20.3	7.7	7	13.7	14.7	15	14.7	18	15
	5°C	18.7	18.3	18.3	17.7	23.3	21.7	22.4	24.7	7.7	7.8	12.7	13	16.7	17	19.2	17
	-20°C	16.0	15.7	19.3	20	19.3	19.3	23	25.7	6	6	11.9	13	17	18	20.7	25
L.S.D at 0.05		n. s.	n. s.	n. s.	n. s.	3.5	n. s.	4.2	n. s.	1.99	1.8	n. s.	2.8	3.5	2.8	n. s.	3.3
		Fresh weight of root (gm)								Dry weight of root (gm)							
15 Oct.	Control	72.2	96.3	197	203	609	607	1088.5	1087	12	17.3	47.7	46	169	168	281.5	297
	5°C	69.4	89.7	177	199	957	955	1303	1558	15.9	24	41.9	48.7	246	245	317.5	389
	-20°C	83.4	111.7	204	205	705.5	715	1128.5	1088	19.5	31	48	56	168	165	279.5	287
15 Nov.	Control	42.9	66	193	194	672	857	652	683	11.4	18.7	52.9	59	157	129	169.5	154
	5°C	73.4	100	232	232.3	542.5	552	659.5	520	15.9	21.3	53.2	52.7	112	126	166	144
	-20°C	42	40	223.7	231.3	479	339	745.5	883	12.2	12.3	53.7	51	118.5	78	189.5	215
15 Dec.	Control	22.5	26	103.7	109	238	243	246.5	363	5	5	22.4	25	56.5	56	60.5	88
	5°C	26	26	78.5	68	260	219	322	456	5.7	6	16.8	19.3	71.7	79.3	77.5	109
	-20°C	16.7	18	70.7	78.7	261.5	245	297.5	429	4	3	17.6	17.6	66	64	65.5	91
L.S.D at 0.05		4.03	4	6.5	3.8	10.03	4.7	12.9	3.6	1.9	1.9	6.8	3.1	3.5	9.4	5.6	6.8

**Table (2):** Effect of the sowing dates and vernalization treatments on root anatomy (mm) of *B. vulgaris* cv. Pleno 180 days from sowing.

Sowing dates	Vernalization treatments	Periderm thickness	Cortex thickness	Average rows number of cortex	Average cortex cell thickness	Average rows number of cambium region	Thickness of cambium region	Average thickness of cambium
15 Oct.	Control	0.31	3.2	23	0.20	13	1.9	0.08
	5°C	0.20	2.3	20	0.20	14	1.2	0.16
	-20°C	0.39	4	22	0.31	10	0.9	0.12
15 Nov.	Control	0.20	2.4	22	0.19	8	0.5	0.12
	5°C	0.39	2.7	18	0.20	7	0.7	0.11
	-20°C	0.23	2.3	16	0.20	16	1.2	0.16
15 Dec.	Control	0.39	2.8	20	0.20	14	1.5	0.13
	5°C	0.23	1.8	18	0.16	10	0.5	0.12
	-20°C	0.35	2	15	0.16	11	0.8	0.08

**Table (3):** Effect of the sowing dates and vernalization treatments on some chemical constituents of *B. vulgaris* cv. Pleno roots taken at 90, 120, 150 and 180 days from sowing in 2009/2010 and 2010/2011 seasons (as mg/g D.W.).

Sowing dates	Vernalization treatments	Total sugars				Total Phenols				Auxin like-substances				Sucrose % at 180 days	T.S.S.
		90 days	120 days	150 days	180 days	90 days	120 days	150 days	180 days	90 days	120 days	150 days	180 days		
15 Oct.	Control	0.39	0.43	0.69	0.44	1.59	1.01	0.45	0.82	0.15	0.34	0.41	0.10	17.2	25
	5°C	0.67	0.55	0.64	0.63	1.29	0.81	1.36	1.95	0.58	0.32	0.41	0.29	16.6	23
	-20°C	0.91	0.36	0.59	0.42	1.10	0.40	1.28	1.10	0.53	0.13	0.33	0.11	15.7	25.7
15 Nov.	Control	1.11	0.86	0.55	0.34	0.66	0.91	0.23	0.95	0.22	0.57	0.44	0.12	15.4	25.7
	5°C	0.98	0.72	0.54	0.75	1.04	2.59	0.45	1.03	0.31	0.35	0.33	0.10	15.8	22.5
	-20°C	0.51	0.43	0.52	0.48	0.61	1.31	0.55	0.79	0.23	0.37	0.46	0.16	15.6	28.3
15 Dec.	Control	0.58	0.37	0.73	0.98	0.40	0.46	0.58	1.21	0.52	0.10	0.10	0.08	15.7	26.3
	5°C	0.38	1.00	0.85	0.43	1.20	0.77	0.85	0.51	0.33	0.38	0.28	0.12	15.5	22
	-20°C	1.04	0.50	0.43	0.83	0.63	1.20	0.63	1.39	0.07	0.22	0.14	0.37	15.2	27

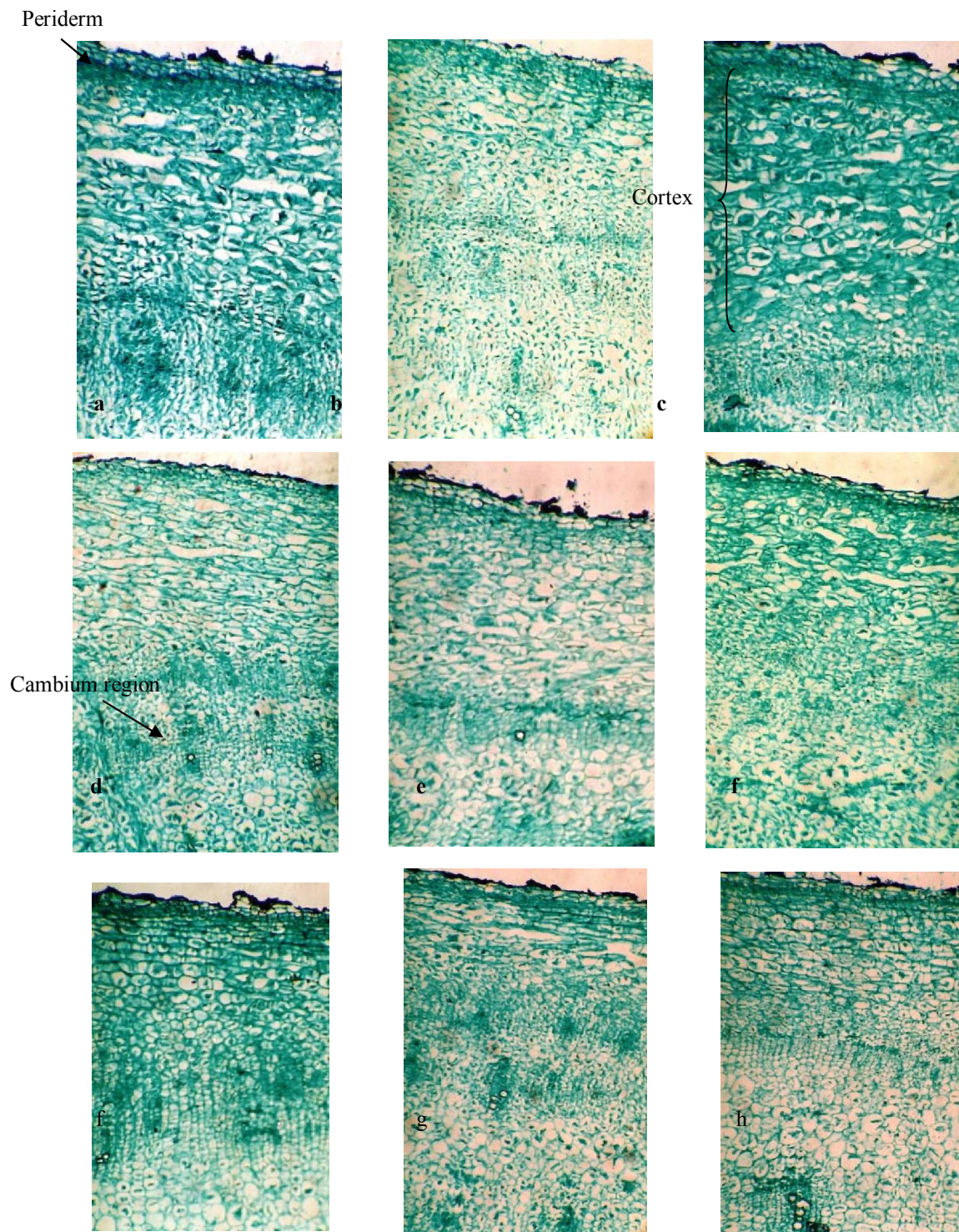

**Figure (1):** Cross sections of *B. vulgaris* cv. Pleno roots (x 25.6).  
 a- 15 Oct. control treatment      b- 15 Oct. under 5°C      c- 15 Oct. under -20°C  
 d- 15 Nov. control treatment      e- 15 Nov. under 5°C      f- 15 Nov. under -20°C  
 g- 15 Dec. control treatment      h- 15 Dec. under 5°C      i- 15 Dec. under -20°C

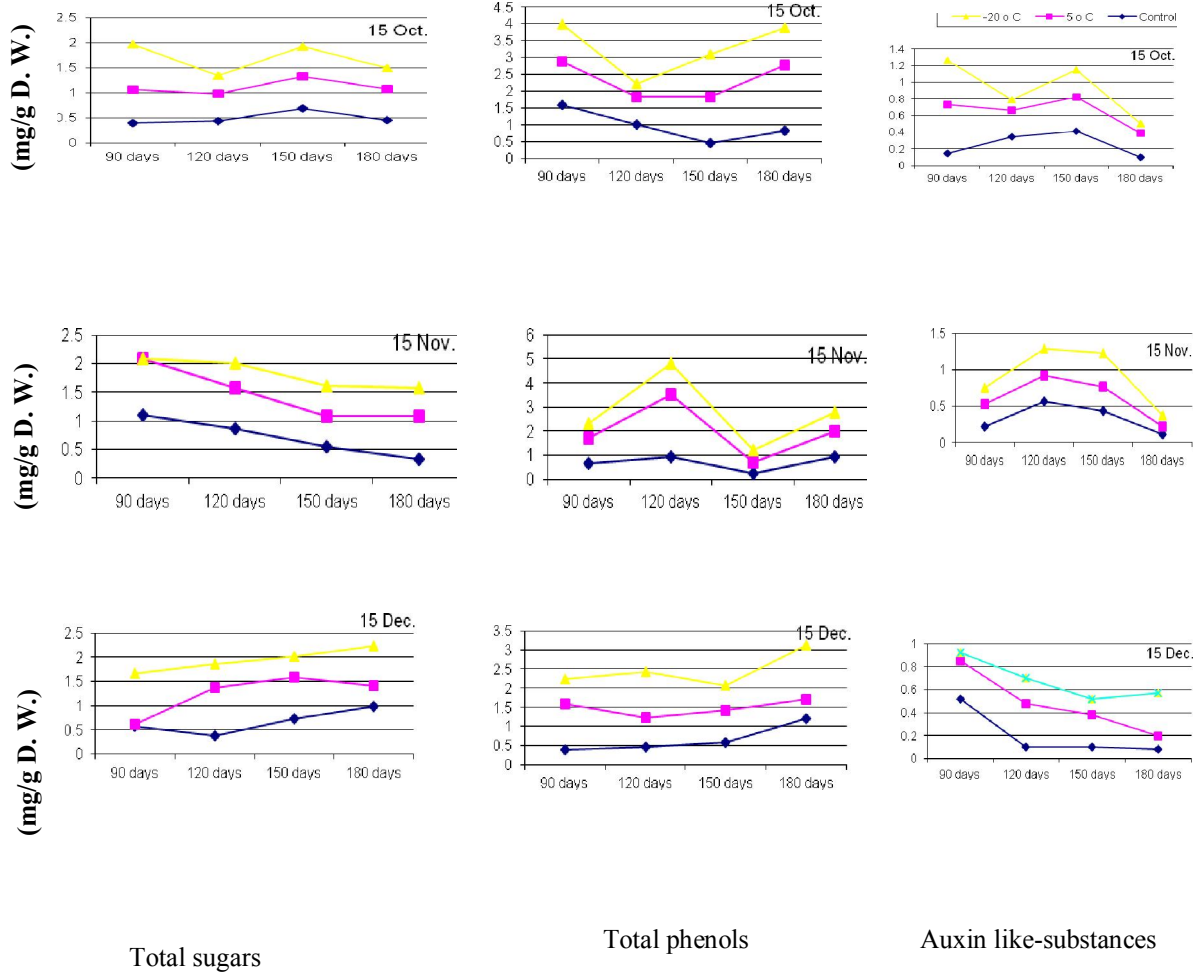

**Figure (2):** Effect of the sowing dates and vernalization treatments on some chemical constituents of *B. vulgaris* cv. Pleno roots taken at 90, 120, 150 and 180 days from sowing in 2009/2010 and 2010/2011 seasons (as mg/g D. W.)

**Total phenols:**

Table (3) indicate that the highest values of total phenols were recorded at 15 Oct. treatment after 90 and 120 days from sowing and 15 Dec. treatment after 150 and 180 days from the sowing. Whereas, the lowest ones were shown at 15 Dec. treatment at 90 and 120 days, 15 Nov. treatment at 150 days and 15 Oct. at 180 days. In most cases, most of the cooling treatments increased of total phenols compared with the control.

**Auxin like-substances:**

Data in (Table 3) shows that, in most cases, the highest values of auxin like-substances were noticed with 15 Nov. treatment. While, the lowest ones, in most cases were observed at 15 Dec. treatment. Generally, most of the studied cooling treatments, in most cases, increased of auxin like-substances in comparison the control. Such results are in agreement with Hassan *et al.* (2008) who mentioned that, in most cases, most of the cooling treatments increased of sugars, phenols and auxin like-substances in comparison the control.

**Corresponding author****S. M. H. Gowayed<sup>1,2</sup>**

<sup>1</sup> Biology Department, Faculty of Science, North Jeddah, King Abdul-Aziz University, KSA

<sup>2</sup> Botany Department, Faculty of Agriculture, Suez Canal University, 41522 Ismailia, Egypt.

[salahgowed@yahoo.com](mailto:salahgowed@yahoo.com)

**References:**

Abdel-Rahman, M., T. Thomas, G.J. Doss and L. Howel, (1975). Changes in endogenous plant hormones in cherry, tomato fruits during development and maturation. *Physiol. Plant.*, 34: 39-43.

Anon. (1990). Association of Official Agriculture Chemists (A.O.A.C.), Official methods of analysis, 15th ed., K. Helrich (Ed), Arlington, VA.

Badawi, M.A, El-Agroudy, M.A. and Attia, A.N. (1995). Effect of planting date and N. P. K. fertilization on growth and yield of sugar beet (*Beta vulgaris*, L.). *J. Agric. Sci. Mansoura Univ.*, 20(6): 2683–2689.

Bugbee, V. M. (1993). Storage in the sugar beet crop. *Science into practice*, ed. By Cooke DA and Scott RK. Chapman and Hall, Cambridge, pp. 551-570.

El-Kassaby, A. T. and A. A. Leilah (1992). Effect of sowing and harvesting time on yield and quality of sugar beet. *Proc. 5th Conf. Agron. Zagazig*, 13–15 Sept., 2: 963–969.

Fliossou, V. (1969). Growth regulators in *Populus hemula* L. distribution of growth inhibitors. *Soil and Plant* 22: 1289-1301.

Gordon, S. A. and R. P. Weber (1951). The calorimetric estimation of IAA. *Plant Physiol.*, 26: 192-195.

Hassan, W. M., O. A. Almaghraby and M. M. Sakr (2008). Effect of sowing dates and vernalization on *Beta vulgaris* L. cv. Univers, (2) Growth, anatomy and some chemical components of the root. *Agr. Res. J. Suea Canal Uni.* 8 (2):41 - 47.

Karbalaei, S., A. Mehraban<sup>1</sup>, H. R. Mobasser and Z. Bitarafan (2012). Sowing Date and Transplant Root Size Effects on Transplanted Sugar Beet in Spring Planting. *Annals of Biological Research*, 3 (7):3474-3478

Leilah, A.A. and Nasr, S.M. (1992). The contribution of sowing and harvesting dates on yield and quality of some sugar beet cultivars. *Proc. 5th Conf. Agron. Zagazig*, 13–15 Sept., 2: 970–979.

Ozturk, O., A. Topal, F. Akinerdem and N. Akgun (2008). Effects of sowing and harvesting dates on yield and some quality characteristics of crops in sugar beet/cereal rotation system. *Journal of the Science of Food and Agriculture* 88, 141-50.

Ramadan, B. S. H. and M. A. Hassanin (1999). Effect of sowing dates on yield and quality of some sugar beet (*Beta vulgaris* L.) varieties. *J. Agric. Sci., Mansoura Univ.*, 24 (7): 3227-3237.

Reeves, P. A., Y. He, R. J. Schmitz (2007). Evolutionary Conservation of the flowering locus C-Mediated Vernalization Response: Evidence From the Sugar Beet (*Beta vulgaris* L.). *Genetics* 176(1):295-307.

Refay, Y. A. (2010). Root Yield and Quality Traits of Three Sugar Beet (*Beta vulgaris* L.) Varieties in Relation to Sowing Date and Stand Densities. *World Journal of Agricultural Sciences* 6 (5): 589-594.

Sadasivam, S. and A. Manickam (1991). *Biochemical methods for agricultural sciences*, 2nd ed. Wiley Eastern Ltd., New Delhi, 246pp.

Steel, R. G. and J. H. Torrie (1980). *Principales and procedures of statistics*. 2<sup>nd</sup> Ed. MC Graw-Hill, New York.

Willey, R. L. (1971). *Microtechnique, A laboratory guide*. Memillan Publishing Co., Inc., N. Y., 99 pp.

William, H., P.A.C. Chilchilo and H. Reynolds (1965). *Official Methods of Analysis of the Association of Agricultural Chemists*. 10th Edn., AOAC., Washington, D.C., pp: 158.

## Effective Social factors on Organizational Learning

<sup>1\*</sup>Davood Gharakhani, <sup>2</sup>Amid Pourghafar Maghferati, <sup>3</sup>Mehrdad Tavakolirad

<sup>1\*</sup>Department of Industrial Management, Qazvin branch, Islamic Azad University (IAU), Qazvin, Iran

E-mail: [Davoodgharakhany@yahoo.com](mailto:Davoodgharakhany@yahoo.com)

<sup>2</sup>Islamic Azad University, Fouman and Shaft Branch, Fouman, Iran. Email: [a\\_pourghafar@yahoo.com](mailto:a_pourghafar@yahoo.com)

<sup>3</sup>Department of Socail Science, Payame Noor Universtiy, PO BOX 19395-3697 Tehran, IRAN. Email: [m\\_tavakolirad55@pnu.ac.ir](mailto:m_tavakolirad55@pnu.ac.ir)

**Abstract:** This study aims to explore and analyze the Social factors that influence the development of Organizational Learning. The paper used analytic hierarchy process (AHP) to ranking the effective Social factors on Organizational Learning. This is the first research project to focus primarily on identifying specific factors in the environment which have a positive impact on Organizational Learning. From the AHP results, we can understand that most important effective Social factor on Organizational Learning is Leadership style. Moreover, the less important effective Social factor on Organizational Learning is various organizational characteristics. The findings of this study can serve as a basis and frame of reference for the future planning of Organizational Learning.

[Davood Gharakhani, Amid Pourghafar Maghferati, Mehrdad Tavakolirad. **Effective Social factors on Organizational Learning.** *Life Sci J* 2012;9(4):1820-1826] (ISSN:1097-8135). <http://www.lifesciencesite.com>. 276

**Keywords:** Social factors, Organizational Learning, MCDM, AHP

### 1. Introduction

During the last two decades the world economy has experienced an extraordinary transformation. Intensified global competition and reorganization of economic boundaries have significantly shortened the product and process lifecycles forcing firms to develop a continuous stream of innovation (Achrol, 1991). To be successful, organizations must not only process information but also acquire and create new information and knowledge. To this end, organizational learning creates competitive advantage by increasing marketing capabilities leading to desired outcomes (Das & Kumar, 2009). Bell et. al. (2002) presented a review of organizational learning literature organized into four different schools of thought - namely, economic, developmental, managerial, and process. Entrepreneurship has never been more important than it is currently, and one of the major challenges facing all economies is the "need to develop a more entrepreneurial culture and develop the necessary skills, attitudes and behaviors to prepare young people and others to pursue opportunities" (Wilson, 2009). Social interactive learning has influential impacts on enabling entrepreneurs to explore opportunities and cope with crises of the new business management (Pittaway & Cope, 2007).

Social interaction has also prominent contributions in developing students' entrepreneurial qualities in pre-launching stage of new venture creation in many ways. First, social interaction improves students' self-awareness of their entrepreneurial capability, their maturity in communication skills and networking, and their ability to apply acquired knowledge and skills to solve

problems (Fuchs, Werner & Wallau., 2008). Second, social interactive learning enhances students' entrepreneurial creativity and innovativeness (Ko & Butler, 2007). Third, knowledge and skills acquired from social interactions between various students having different experiences and perspectives are of a higher level than knowledge and skills acquired by individuals (Pittaway & Cope, 2007). Furthermore, social interaction creates a synergy between individual and collective learning which makes entrepreneurial learning more in-depth and longer-lasting (Man & Yu, 2007). Many knowledge management definitions exist. For the purpose of this paper, only selected definitions will be focused on. Gloet and Terziovski (2004) describe knowledge management as the formalization of and access to experience, knowledge, and expertise that create new capabilities, enable superior performance, encourage innovation, and enhance customer value. The authors also describe knowledge management as an umbrella term for a variety of interlocking terms, such as knowledge creation, knowledge valuation and metrics, knowledge mapping and indexing, knowledge transport, storage and distribution and knowledge sharing. Organizational structure comprises the organizational hierarchy, rules and regulations, and reporting relationships and is considered a means of co-ordination and control whereby organizational actors can be directed towards organizational effectiveness. Organisations reduce uncertainty by acquiring information through periodical reports, rules, operational standards, procedures and data analysis in an objective manner. For uncertainties to be reduced, it is necessary for there to be a transfer of explicit knowledge, which can



be formalised and easily understood. Corbett (2005) utilized Kolb's theory of experiential learning when he examined the meaning of learning in the recognition of entrepreneurial opportunities. He based his examination on Hills et al.'s (1999) model of the opportunity recognition process which he connected with Kolb's learning styles. According to Corbett, convergent and assimilative learning styles offer good qualifications for finding an entrepreneurial opportunity. Divergent and accommodative styles, on the other hand, are useful in evaluating possibilities and in planning the execution. Corbett justifies his perspective by arguing that, in the phase of finding opportunities, the ability to perceive entities and to solve problems is especially needed. Whereas in the formation phase the emphasis is on the active testing of possibilities Entrepreneurs have generally been seen as operation-oriented persons (Bird, 1988) who believe in learning by doing and absorb things through experiments and mistakes (Baum et al., 2003). Moreover, Baum et al. (2003) noticed that the firms owned by entrepreneurs who learn by practical experience and active testing are more likely to achieve faster growth. Experimental learning is also of interest in researching habitual entrepreneurship.

## 2. LITERATURE REVIEW

### 2.1 Entrepreneurial learning

Entrepreneurial learning is usually defined as a continuous process leading to the development of knowledge required for starting and managing a firm (Politis, 2005). For example, according to Smilor, efficient entrepreneurs are often exceptionally good learners who learn from almost all their experiences; for example, by working with their customers, suppliers and competitors. Important events which threaten the continuity of the firm have been observed to be good sources of learning (Cope, 2003). Kolb is one of the best-known researchers of experiential learning and his theory is presented in this study because it is central to most recent studies seeking to model entrepreneurial learning (Corbett, 2005; Politis, 2005). Experiential learning is a process by which knowledge is created through the transformation of experience. In Kolb's theory learning is a four-stage cycle involving four adaptive learning styles: concrete experience, reflective observation, abstract conceptualization and active experimentation. Concrete experiences (i.e. previous learning results) form the core of the circle model. The meaning of an experience is contemplated through reflective observations, after which an opinion is formed about why a certain experience happened. This opinion or theory is finally tested through active experimenting. Learning requires both understanding the experience and converting it according to each situation. Kolb identifies four different elementary forms of

knowledge: assimilative, convergent, divergent and accommodative knowledge. Entrepreneurial experience has been examined as an individual characteristic influenced by the entrepreneur's personal history and work experience (Reuber and Fischer, 1999). According to Reuber and Fischer (1999), entrepreneurial experience consists of proficiency developed over the course of time (stock of experience) and knowledge accumulated through certain discrete events (stream of experience). Westhead et al. (2005), for example, made the observation that there are differences between novice and habitual entrepreneurs especially the latter's greater experience.

Previous entrepreneurial experience can facilitate the recognition of new opportunities and accumulated managerial knowledge and technical know-how together with existing networks intensify the exploitation of those opportunities (Westhead et al., 2004). Entrepreneurial experience makes it possible to recognise the measures needed to develop the business and networks provide access to information and resources reducing the disadvantages of novelty and lack of size (Starr and Bygrave, 1991).

A review of the literature on entrepreneurial learning indicates that the concept has been defined based on the acquired knowledge and skills in two stages of entrepreneurship process. First stage is pre-launching where individuals learn requisite knowledge and competencies for new venture creation and leadership (Heinonen & Poikkijoki, 2006; Erikson, 2003). Therefore, entrepreneurial learning in this stage is the cognitive processes of gaining and structuring entrepreneurial knowledge and skills (Rae & Carswell, 2000) and educators attempt to effectively equip students with theoretical knowledge and practical skills of entrepreneurship (Fayolle & Gailly, 2008). Second stage is post-launching where entrepreneurs learn and develop their competencies through performing different tasks and roles involved in entrepreneurship and facing the challenges and problems of leading entrepreneurial activities (Kempster & Cope, 2010). In effect, entrepreneurial learning in post-launching stage reflects the dynamic processes of acquiring, assimilating, and organizing new information and knowledge and incorporating them with pre-existing structures in order to successfully leading entrepreneurial routine and strategic tasks and roles (Holcomb et al., 2009). Therefore, learning encompasses acquiring knowledge from past experiences, combining learning from various resources, and transferring the knowledge and skills to effectively leading entrepreneurial activities (Politis, 2005). Entrepreneurship training programs at this stage concentrate on equipping entrepreneurs with competencies to analyze their past experiences

specifically their failures and transfer the information and knowledge to effectively leading their new businesses (Politis & Gabrielsson, 2009).

## 2.2 Social entrepreneurship

Traditionally the free market and aid (from the rich countries to the poor) have been seen as the alleviators of poverty but, as Handy (1997) has recognized, markets can lower standards as well as raise them. As a consequence, they can deepen rather than reduce differences. At the same time, five decades of foreign aid have failed to reduce global poverty, and it is being recognized, increasingly, that “aid is neither necessary nor sufficient to ensure sustainable development and poverty reduction in poor countries” (Griffiths and Tan, 2007). This has led several commentators to suggest that what is needed are different forms of intervention, among which are an enterprise approach to poverty alleviation by building “commercially sustainable companies that create jobs and empower the poor to improve their livelihoods” (Griffiths and Tan, 2007). In this article, therefore, social entrepreneurship is perceived to be about applying the expertise, talents and resources of entrepreneurs to the variety of problems developing countries face, such as education, health, personal safety and security, poverty alleviation, social advancement, environmental sustainability, and so forth. Although rooted in Victorian social philanthropy, modern social enterprise is a relatively new phenomenon (Alvord et al., 2004) and although there is a lack of any universally agreed definition of the term (Henry et al., 2006), there is broad agreement (Bishop and Green, 2008) that social entrepreneurs “bring to social problems the same enterprise and imagination that business entrepreneurs bring to wealth creation”. How do entrepreneurs learn and how can learning be seen in their entrepreneurial activities? Many different researchers have sought to find answers to these questions, for example, by using the critical incident technique (Cope and Watts, 2000) and the narrative method (Rae, 2000). Most researchers have, however, focused on entrepreneurs in general, whereas learning in the context of habitual entrepreneurship has been of less interest.

The organisational culture must foster debate and understanding for knowledge ambiguity to be reduced. The type of media selected should assist in processing “rich” information. Daft and Lengel (1986) consider “information richness” as “the ability of information to change perception within a certain time interval”. Therefore, the form of communication used to transfer ambiguous knowledge should be rich, that is it should facilitate understanding (Daft and Lengel, 1986). The richness of the media used could be characterised by its capacity to allow sharing of visions, insights, swift understanding and the use of a variety of languages.

## 2.3 Organizational Learning

In bringing together firms with different skills and knowledge bases, alliances create unique learning opportunities for the partner firms (Inkpen 1998). Organizational learning is the acquisition of new knowledge by the actors, who are able and willing to apply that knowledge in making decisions or influencing others in the organization (Miller 1996). Organizational learning is both a function of access to new knowledge and the capabilities for using and building on such knowledge. Interactive learning allows managers to exchange a good deal of information with one another which fosters more realistic collaboration (Das & Kumar, 2007). Characteristic of entrepreneur played an important role on ensuring the business success in organization. Characteristic of entrepreneur referred to demographic characteristic, individual characteristic, personal traits, entrepreneur orientation, and entrepreneur readiness. Several previous studies found that demographic characteristics, such as age and gender, and individual background, e.g. education and former work experience, had an impact on entrepreneurial intention and endeavor, personal qualities and traits, such as self-confidence and perseverance, entrepreneurial orientation, e.g. autonomy, innovativeness, risk taking, pro-activeness, competitive aggressiveness, and motivation, entrepreneurial readiness in this study refers to self-efficacy.

## 2.4 Top Management Attitude toward Learning

Attitudes are learned states that influence the choice of personal action the individual makes toward persons, objects, or events (Chakraborty et. al., 2007). The management of knowledge has become an important role for top management (Prahalad and Hamel 1994). Successful, organizations must not only process information but must also acquire and create new information and knowledge. Based on the top management’s attitude toward learning, in some alliances, partners aggressively seek to acquire knowledge and skills where as in others’ the partners take a more passive approach to knowledge acquisition and learning (Vantinen & Pyhalto, 2009).

## 2.5 Effective Social factors on Organizational Learning

In recent years, the social aspects of Organizational Learning have become clearer than before.

Amabile (1988) concluded nine stimulants:

- (1) Freedom;
- (2) Good project management;
- (3) Sufficient resources;
- (4) Encouragement;
- (5) Various organizational characteristics;
- (6) Recognition;
- (7) Sufficient time;

- (8) Challenge; and  
(9) Pressure.

Andriopoulos (2001) reviewed the literature dealing with the factors that contribute to Learning in an organization and concluded that there are five critical factors to it:

- (1) Organizational climate;
- (2) Leadership style;
- (3) Resources and skills;
- (4) Organizational culture; and
- (5) Structure and systems.

Maken (1991) suggested that there are six factors that improve the Learning of hotel salespersons. These factors are:

- (1) Encouragement and rewards for creativity;
- (2) Exposure to outside stimuli;
- (3) The provision of in-house training and education;
- (4) Encouragement for organized work habits;
- (5) Planning for participatory management and career enrichment; and
- (6) Paving the way for professional development.

### 3. Research Methodology

Researcher tries to recognize the Effective Social factors on Organizational Learning, which is

done through library studies, design and distribution of questionnaire and also interview with different manufacturing companies' experts, Effective Social factors on Organizational Learning is classified into 3 major criteria and 12 minor criteria. In second stage, the researcher makes decisions matrix in order to ranking the recognized criteria. In order to gather these data, another questionnaire is designed and distributed among 10 experts in IT industry.

### 4. Data analysis techniques

After completion of the questionnaire No. 2, its data were integrated using Expert Choice Software. This software includes wide range of facilities for obtaining people's paired comparisons matrix and then integration of different people's matrices and making a single matrix. EC Software was also used to achieve relative weight and final criteria and final ranking of Effective Social factors on Organizational Learning.

#### 4.1 Data analysis

Here, the data achieved from Analytical Hierarchy Process (AHP) are depicted in the form of the following tables:

criteria	relative weight	total weight	rank
Managerial factors	0.432	0.432	1
Organizational factors	0.241	0.241	3
Strategic factors	0.327	0.327	2

sub-criteria	relative weight	total weight	rank
Recognition	0.116	0.0501	11
Encouragement	0.212	0.0916	4
Leadership style	0.405	0.1749	1
training and education	0.267	0.1153	3

sub-criteria	relative weight	total weight	rank
Organizational climate	0.237	0.0571	10
Organizational culture	0.320	0.0771	5
Various organizational characteristics	0.128	0.0309	12
Structure and systems	0.315	0.0759	6

sub-criteria	relative weight	total weight	rank
Freedom	0.193	0.0631	9
Resources and skills	0.373	0.1219	2
Paving the way for professional development	0.202	0.0660	8
Planning for participatory management	0.232	0.0758	7

According to the results, experts believe that the most important Effective Social factor on Organizational Learning is Leadership style, whose total weight is 0.1749. Resources and skills is the second factor. The less important effective Social factor on Organizational Learning is Recognition with total weight of 0.0501 and various organizational characteristics with total weight of 0.0309.

For better understanding of ranking the Effective Social factor on Organizational Learning, three main criteria and known 12 criteria along with their relative and total weights are depicted in table 5.

main criteria	Weight of the main criteria	sub-criteria	Weigh criteria in sub group	total weight	rank
Managerial factors	0.432	Recognition	0.116	0.0501	11
		Encouragement	0.212	0.0916	4
		Leadership style	0.405	0.1749	1
		training and education	0.267	0.1153	3
Organizational factors	0.241	Organizational climate	0.237	0.0571	10
		Organizational culture	0.320	0.0771	5
		Various organizational characteristics	0.128	0.0309	12
		Structure and systems	0.315	0.0759	6
Strategic factors	0.327	Freedom	0.193	0.0631	9
		Resources and skills	0.373	0.1219	2
		Paving the way for professional development	0.202	0.0660	8
		Planning for participatory management	0.232	0.0758	7

## 5. Conclusion

The purpose of this paper is identify and ranking the effective Social factors on Organizational Learning. The research results show that among main recognized criteria, Managerial factors , Strategic factors and Organizational factors are respectively ranked as the most important Social factor on Organizational Learning in case study. According to experts also, among 12 recognized sub-criteria, factors such as Leadership style, Resources and skills, training and education and Encouragement are are respectively known as important factors of Organizational Learning and are of higher priority and importance. Moreover, the less important effective Social factor on Organizational Learning is various organizational characteristics. Several previous studies found that demographic characteristics, such as age and gender, and individual background, e.g. education and former work experience, had an impact on entrepreneurial intention and endeavor, personal qualities and traits, such as self-confidence and perseverance, entrepreneurial orientation, e.g. autonomy, innovativeness, risk taking, pro-activeness, competitive aggressiveness, and motivation, entrepreneurial readiness in this study refers to self-efficacy. There are other multiple attribute decision-making methods such as TOPSIS and VIKOUR, which could be applied for ranking the effective Social factors on Organizational Learning.

## Corresponding author

Davood Gharakhani  
Department of Industrial Management, Qazvin branch, Islamic Azad University (IAU), Qazvin, Iran  
E-mail: [Davoodgharakhany@yahoo.com](mailto:Davoodgharakhany@yahoo.com)

## References

1. Achrol, R.S. (1991), "Evolution of the marketing organization: new forms of turbulent environment," *Journal of Marketing*, Vol. 55 No. 4, pp. 77-93.
2. Alvord, S.H., Brown, L.D. and Letts, C.W. (2004), "Social entrepreneurship and societal transformation", *Journal of Applied Behavioral Science*, Vol. 40 No. 3, pp. 260-82.
3. Amabile, T.M. (1988), "A model of creativity and innovation in organizations", *Research in Organizational Behavior*, Vol. 10, pp. 123-67.
4. Andriopoulos, C. (2001), "Determinants of organizational creativity: a literature review", *Management Decision*, Vol. 39 No. 10, pp. 834-40.
5. Baum, J.R., Bird, B. and Chardavoyne, N.A. (2003), "The relationship of entrepreneur's learning orientations and practical intelligence to new venture performance", *Frontiers of Entrepreneurship Research*, Babson College, Babson Park, MA.

6. Bell, S.J., Whitwell, G.J., and Lukas, B.A. (2002), "School of thoughts in organizational learning," *Journal of Academy of Marketing Science*, Vol. 30 No. 1, pp. 70-86.
7. Bird, B. (1988), "Implementing entrepreneurial ideas: the case for intention", *Academy of Management Review*, Vol. 13 No. 3, pp. 442-53.
8. Bishop, M. and Green, M. (2008), *Philantropic Capitalism*, Bloomsbury, New York, NY.
- Chell, E., Karata-Ozkan, M. and Nicolopoulou, K. (2007), "Social entrepreneurship education: policy, core themes and development competencies", *The International Journal of Entrepreneurship Education*, No. 5, pp. 143-62.
9. Chakraborty, G., Srivastava, P., and Marshall, F.R (2007), "Are drivers of customer satisfaction different for buyers/users from different functional areas?" *Journal of Business and Industrial Marketing*. Vol. 22 No. 1, pp. 20-28.
10. Cope, J., & Watts, G. (2000). Learning by doing: An exploration of experience, critical incidents and reflection in entrepreneurial learning. *International Journal of Entrepreneurship Behaviour and Research*, 6(3), 104-124.
11. Cope, J. (2003). Entrepreneurial learning and critical reflection: Discontinuous events as triggers for 'higher-level' learning. *Management Learning*, 34(4), 429-450.
12. Corbett, A. C. (2005). Experiential learning within the process of opportunity identification and exploitation. *Entrepreneurship Theory and Practice*, 29(4), 473-398.
13. Corbett, A. (2005), "Experiential learning within the process of opportunity identification and exploitation", *Entrepreneurship Theory & Practice*, Vol. 29 No. 4, pp. 473-91.
14. Daft, R.L. and Lengel, R.H. (1986), "Organisational information requirements, media richness and structural design", *Management Science*, Vol. 32 No. 5, pp. 554-71.
15. Das, T.K. and Kumar, R. (2007), "Learning dynamics in the alliance development process", *Management Decision*, Vol. 45, pp. 684-707.
16. Das, T.K. and Kumar, R. (2009), "Interpartner harmony in strategic alliances: managing commitment and forbearance," *International Journal of Strategic Business Alliances*, Vol. 1, pp. 24-52.
17. Erikson, T. (2003). Towards a taxonomy of entrepreneurial learning experiences among potential entrepreneurs. *Journal of Small Business and Enterprise Development*, 10(1), 106-112.
18. Fayolle, A., & Gailly, B. (2008). From craft to science, Teaching models and learning processes in entrepreneurship education. *Journal of European Industrial Training*, 32(7), 569-593.
19. Fuchs, K., Werner, A., & Wallau, F. (2008). Entrepreneurship education in Germany and Sweden: what role do different school systems play? *Journal of Small Business and Enterprise Development*, 15(2), 365-381.
20. Gloet, M. and Terziowski, M. (2004), "Exploring the relationship between knowledge management practices and innovation performance", *Journal of Manufacturing Technology Management*, Vol. 15 No. 5, pp. 402-9.
21. Griffiths, B. and Tan, K. (2007), *Fighting Poverty through Enterprise: The Case for Social Venture Capital*, Transformational Business Networks, London.
22. Heinonen, J., & Poikkijoki, Sari-Anne. (2006). An entrepreneurial-directed approach to entrepreneurship education: mission impossible? *Journal of Management Development*, 25(1), 80-94.
23. Henry, N., Johnson, T. and Spear, R. (2006), *Social Enterprise: An International Literature Review*, GHK, London.
24. Hills, G.E., Shrader, R.C. and Lumpkin, G.T. (1999), "Opportunity recognition as a creative process", *Frontiers of Entrepreneurship Research*, Babson College, Babson Park, MA.
25. Holcomb, T. R., Ireland, R. D., Holmes Jr., R. M., & Hitt, M. A. (2009). Architecture of entrepreneurial learning: Exploring the link among heuristics, knowledge, and action. *Entrepreneurship Theory and Practice*, 33(1), 167- 192.
26. Inkpen, A.C. (1998), "Learning, knowledge acquisition, and strategic alliances," *European Management Journal*, Vol. 16 No. 2, pp. 223-229.
27. Kempster, S.J. & Cope, J. (2010). Learning to lead in the entrepreneurial context. *Journal of Entrepreneurial behaviour and Research*, 16(6), 5-34.
28. Ko, S., & Butler, J. E. (2007). Creativity: A key link to entrepreneurial behaviour. *Business Horizons*, 50, 365-372.
29. Maken, J.C. (1991), "Hotel salespersons: enhancing their creativity and efficiency", *Cornell Hotel and Restaurant Administration Quarterly*, Vol. 32 No. 1, pp. 52-7.
30. Man, T. W. Y., & Yu, C. W. M. (2007). Social interaction and adolescent's learning in enterprise education: An empirical study. *Education + Training*, 49(8/9), 620-633.
31. Miller, D. (1996), "A preliminary typology of organizational learning: synthesizing the literature," *Journal of Management*, Vol. 22 No. 3, pp. 485-516.

32. Pittaway, L., & Cope, J. (2007). Simulating entrepreneurial learning: Integrating experiential and collaborative approaches to learning. *Management Learning*, 38(2), 211–233.
33. Politis, D. (2005). The process of entrepreneurial learning: A conceptual framework. *Entrepreneurship Theory and Practice*, 29(3), 399-424.
34. Politis, D., & Gabrielsson, J. (2009). Entrepreneurs' attitudes towards failure: An experiential learning approach. *International Journal of Entrepreneurial Behaviour & Research*, 15(4), 364-383.
35. Politis, D. (2005). The process of entrepreneurial learning: A conceptual framework. *Entrepreneurship Theory and Practice*, 29(3), 399-424.
36. Prahalad, C.K. and Hamel, G. (1994), "Strategy as a field of study: why search for a new paradigm," *Strategic Management Journal*, Vol. 15, pp. 5-16.
37. Rae, D., & Carswell, M. (2000). Using a life-story approach in entrepreneurial learning: the development of a conceptual model and its implications in the design of learning experiences. *Education + Training*, 42(4/5), 220-7.
38. Reuber, A.R. and Fischer, E. (1999), "Understanding the consequences of founders' experience", *Journal of Small Business Management*, Vol. 37 No. 2, pp. 30-45.
39. Starr, J.A. and Bygrave, W.D. (1991), "The assets and liabilities of prior start-up experience: an exploratory study of multiple venture entrepreneurs", *Frontiers of Entrepreneurship Research*, pp. 213-27.
40. Vanttinen, M and Pyhältö K. (2009), "Strategy process as an innovative learning environment", *Management Decision*, Vol. 47 No. 5, pp. 778-791.
41. Westhead, P., Ucbasaran, D. and Wright, M. (2004), "Experience and cognition: do novice, serial and portfolio entrepreneurs differ?", paper presented at the 13th Nordic Conference on Small Business Research, Tromsø, 10-12 June.
42. Wilson, K. (2009), "Executive summary", in Volkmann, C., Wilson, K.E., Mariotti, S., Rabuzzi, D., Vyakarnam, S. and Sepulveda, A. (Eds), *Educating the Next Wave of Entrepreneurs: Unlocking Entrepreneurial Capabilities to Meet the Global Challenges of the 21st Century*, World Economic Forum, Geneva.

10/18/2012

## Derivation of a single reservoir operation rule curve using Genetic Algorithm

Haghiabi Amirhamzeh

Department of Water Engineering, Lorestan University, Khorramabad, Iran,  
[haghiabi2@yahoo.com](mailto:haghiabi2@yahoo.com)

*Abstract:* Genetic algorithms, founded upon the principle of evolution, are applicable to many optimization problems, especially popular for solving parameter optimization problems. Reservoir operating rule curves are the most common way for guiding and managing the reservoir operation. These rule curves traditionally are derived through intensive simulation techniques. In this paper to drive rule curve of a single storage system in Karkheh basin a genetic algorithm developed. In this model, the objective function is minimizing loss, considering the various inputs. Constraints that were in the reservoir, including constraints of reservoir continuity and constraints relating to volume, maximum and minimum operation and value of released. Decision variable is the amount needed to provide release **Derivation of a single reservoir operation rule curve using Genetic Algorithm. Life Sci J 2012;9(4):1827-1830** (ISSN:1097-8135). <http://www.lifesciencesite.com>. 277

.Key-Words: optimization, rule curve, genetic algorithm, drought index

### 1 Introduction

Reservoirs can increase the reliability of the programs in promoting livelihood, raising agricultural productivity and reducing farmers' vulnerability to droughts. In order to overcome the problem of insufficient water supply during periods of low flow, attention has been drawn to improvement of water resources management, especially in optimization of reservoir operations (Chan and Cheng, 2005). Real time operation of River-Reservoir Systems (RRS) needs specific operational strategies. These strategies are practical guides for storage and/or releasing water in order to meet the human water demands, flood control and other objectives of reservoir operation management. Operational strategies can be either static or dynamic. Dynamic operational strategies are concerned with stochastic parameters of input current and variations of reservoir characteristics. One of the simplest reservoir operating strategies is "rule curve" which gives end-of-month values of reservoir storage volume (Karamouz & Kerachian, 2008). Genetic algorithm has been mostly used for solving hydro-engineering problems in supply network optimization, underground water resource management and extraction of reservoir operating rules. Esat & Hall (1994) employed a genetic algorithm to the linear four- reservoir problem ;the objective was to maximize the benefits of energy generation and irrigation under constant condition of storage and releasing water from the reservoir. Oliveira & Loucks (1997) used genetic algorithm to evaluate operating rules of multi-reservoir systems and showed that the genetic algorithm can be employed to specify operational strategies. The significant characteristic of the genetic algorithm, in this regard, is its freedom of action to specify, define and evaluate operating

strategies. Tung *et al.* (2003) presented a specific kind of rule curve including optimal operational areas from a reservoir. They took the height of the point where the rule curve is broken as the decision variables of the problem. Using that, they submitted their rule curve which included optimal operational areas from a reservoir. Hormwichean *et al.* (2009) used a Simulation-Optimization model in order to design a rule curve for a single-reservoir system. To simulate the reservoir system, they used the equations governing HEC-3 Simulation model. They also used genetic algorithm in their system optimization. By presenting a special kind of genetic algorithm called "Constrained Genetic Algorithm", Chang *et al.* (2010) proposed an operational strategy for a multi-use reservoir. They presented a mathematical model explaining how to convert a constrained system to a non constrained one. This study proposes a constrained genetic algorithm (CGA) for water resources management that incorporates human needs and ecological sustainability requirements. The penalty function is established in a constrained genetic algorithm adopted to search for the feasible solutions of reservoir operations in different yearly hydrological events in order to achieve the demand in wet and dry seasons.

### 2 Problem Formulation

In order to determine optimal rule curve, one simulation-optimization model was used. With the assumption of the deterministic inflows, some relations are formed between regulated outputs and other parameters and variables. These relations were incorporated into continuous equations and other operational criteria. Furthermore, they were added as constraints to the optimization model. Using the

Shiang Shi Weriol (1994) criterion, index ID (K) was employed for determining the relative conditions of wet and dry year's conditions. Based on above criterion, annual inflows into the reservoir were ranked from 1 to 5 using index ID (K) (K=1,2,..5), in terms of the relative wet or dry year conditions. Using this ranking, the model is capable of determining different year conditions (five ranks of dryness or wetness).

**2.1 Drought index**

The Shiang Shen Weriol criterion was used for determining the relative drought conditions. If  $I_m$  is long-term annual flow average and  $I$  is annually flow average and  $s$  denotes the standard deviation of long-term annual discharge, we have:

$$\begin{aligned} \frac{I - I_m}{S} < -1 & \text{ very dry} \\ -1 < \frac{I - I_m}{S} < -0.5 & \text{ dry} \\ -0.5 < \frac{I - I_m}{S} < 0.5 & \text{ normal} \\ 0.5 < \frac{I - I_m}{S} < 1 & \text{ wet} \\ 1 < \frac{I - I_m}{S} & \text{ verywet} \end{aligned} \tag{1}$$

**2.2 Objective function**

As it was mentioned before, submitting a scant deficit in the current time period for decreasing the intensity of a dramatic deficit could be economical. Obviously, despite operational restrictions, the minimum and maximum regulated flows should be within a range which its fluctuation could be tolerated by consumers. Increasing the range of regulated flows is equal to decreasing its fitness. Therefore, a definite relationship between regulation flow values and imposed deficits and excesses was established and model objective function has been defined in form of maximization of regulation flow values. So, a penalty function is defined in terms of deficit or excess. Therefore, we have,

$$\begin{aligned} \text{Max } UF &= 1 - k_1 \cdot \text{Def}^2 - k_2 \cdot \text{Exc}^2 \\ \text{Def} &= \text{Max} \left\{ 0, \left[ \sum_{d=1}^{Nd} \sum_{t=1}^{NT} (\text{dem}(d, ID, t) - \sum_{t=1}^{NT} O(t, Y)) \right] \right\} \\ \text{Exc} &= \text{Max} \left\{ 0, \left[ \sum_{t=1}^{NT} O(t, Y) - \sum_{d=1}^{Nd} \sum_{t=1}^{NT} (\text{dem}(d, ID, t)) \right] \right\} \end{aligned} \tag{2}$$

Where UF is the degree of system fitness and  $k_1$  &  $k_2$  are constants. With the increase of sensitivity, the operators of  $k_1$  &  $k_2$  increase and fitness of the regulated flows of smaller and bigger values than the demand decreases. Appropriate selection of  $k_1$  &  $k_2$  coefficients depends not only on performance functions and plant sensitivity to water deficit tensions, but also the management of transmission, distribution of water and even social tensions. It should be noted that these coefficients are representative of overall condition of desired sites. It is clear that along with the increase of above-mentioned coefficients, the system flexibility will be diminished too; Defis the deficit amount in a year and "dem(d, ID, t)" is the required deficit amount of "d" in the time period of "t" according to ID<sup>th</sup> element of wetness-dryness conditions; "O(t,Y)" is reservoir output in the time step of "t" in the Yth year and "Exc" equals to the sum of annual excess regulation flow.

**2.3 Constraints**

The Continuous constraints and system capacity

$$V(t, Y) = V(t-1, Y) + I(t, Y) - O(t, Y) - L(t, Y) \tag{3}$$

$$t = 1 \dots Nt, Y = 1 \dots NY$$

$$L(t, Y) = \left[ a_0 + a \frac{V(t-1, Y) + V(t, Y)}{2} \right] \cdot e(t) \tag{4}$$

$$V(t, Y) < V_{MAX} \tag{5}$$

$$V(t, Y) > V_{MIN} \tag{6}$$

$$V(Nt, NY) = V(0, 0) \tag{7}$$

$$V(t, Y) \geq 0 \tag{8}$$

$$O(t, Y) \geq 0 \tag{9}$$

$$L(t, Y) \geq 0 \tag{10}$$

$V(t, Y)$ = reservoir storage volume in the time step t in the year Y,  $I(t, Y)$ = inflow to the reservoir in the time step t in the year Y,  $O(t, Y)$ = outflow to the reservoir in the time step t in the year Y,  $L(t, Y)$ = reservoir losses in the time step t in the year Y,  $e(t)$ = vaporization height in the time step t,  $a_0$  : y-intercept of the characteristic curve of reservoir, a: slope of the characteristic curve of reservoir.

$$O(t, Y) = b_0(ID(k), t) + b_1(ID(k), t) V(t-1, Y) \tag{11}$$

$$t = 1 \dots Nt, Y = 1 \dots NY$$

$b_0$  = y-intercept of reservoir rule curve,  $b_1$  = slope of reservoir rule curve

**2.4 Architecture of simulation-optimization model**

The reservoir operation model used in this study includes sub-sections of simulation and optimization model. The optimizer of this system includes a constrained genetic algorithm. First, generations of model decision variables that are  $b_0$  ,  $b_1$  are defined randomly and inserted into sub-section of simulation as the inputs and in this level, using system



cohesion relations and steering technical examination, and other model parameters including regulation currents and excess amount are determined and evaluated. In the next step, the evaluated chromosomes are inserted into genetic algorithm sub-section for accomplishment of crossover, mutation and reproduction operations. The modified generation is delivered again to simulation sub-section; this process is repeated until the system convergence is reached. In Fig.1 the function of simulation-optimization model is presented.

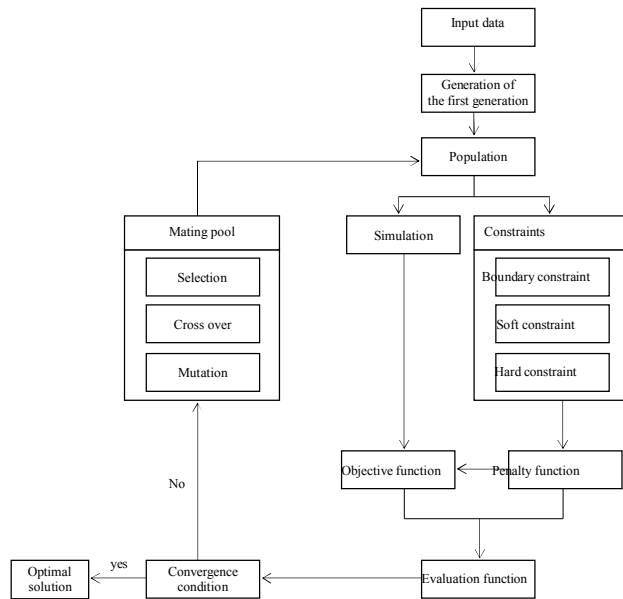

Fig 1. Architecture of Simulation-Optimization model

### 2.5 Penalty functions

These functions are defined in the way that equilibrates between keeping some infeasible solutions and rejecting some of infeasible solutions. In order to accomplish this task, penalty functions are defined as follows:

$$G(1) = -C(1)O(t, Y) \quad \text{IF } O(t, Y) < 0 \quad (12)$$

$$G(2) = (V(t, Y) - V_{MAX})C(2) \quad \text{IF } V(t, Y) > V_{MAX} \quad (13)$$

$$G(3) = (V_{MIN} - V(t, Y))C(3) \quad \text{IF } V(t, Y) < V_{MIN} \quad (14)$$

$$G(4) = |V(N, NY) - V(0, 0)|C(4) \quad \text{IF } V(N, NY) \neq V(0, 0) \quad (15)$$

where G(1) denotes the penalty function of negative releasing; C(1) is a constant; G(2) is the penalty function of storage more than maximum storage volume; C(2) is a constant; G(3) is penalty function of storage lesser than minimal reservoir volume; C(3) is a constant; G(4) denotes penalty function for destabilizing the reservoir balance during the planning period and C(4) is a constant.

### 2.6 The fitness function

For completing the constrained genetic algorithm, model constraints should be mixed with Objective function (UF) to the fitness function guides the searching procedure the optimum solution by imposing appropriate penalties of  $P(\vec{S})$  Fitness function equation is defined as

$$F(\vec{S}) = f(\vec{S}) \cdot P(\vec{S})$$

$$P(\vec{S}) = 1 + \sum_{j=1}^{nc} G_j(\vec{S}) \quad j = 1 \dots nc \quad (16)$$

Where  $\vec{S}$  is the decision variable vector;  $F(\vec{S})$  is fitness function;  $f(\vec{S})$  denotes objective function, and nc is constraints number of the model.

### 2.7 Convergence conditions

For controlling the convergence conditions of algorithm, two criterions have been used: fitness re crossover rate one and maximum generation numbers one. Fitness recrossover rate is a generation fitness growth average in comparison with that of old generation and maximum generation number is repetition number of processes related to generation recrossover and reproduction.

### 3 Problem Solution

The Karkheh dam was studied. Karkheh reservoir dam (earth fill with clay core) is constructed on the Karkheh River. This river is the Iran's third biggest river considering water yield and it is regarded as a wild river with flooding regime. This river with 900 KM length, originates in the central and south western zones of Zagros Mountain range and extending from north to south flows into Hoor-al-azim lagoon and Hoor-al-hoveizeh in the south western regions of Khuzestan province. Among the main objectives of Karkheh reservoir dam is controlling 70 percent of Karkheh river surface runoff for the following proposes: Irrigation of about 220000 hectares (544000 acres) of the lands of downstream plains, which are placed on Pay-e-Pol (Avan, Dosaleq, Arayez, and Baqeh), and also Hamidi-yeh, Ghods, Dasht-e Azadegan, Dasht-e -Abbas plains which are located in the north-west and the west of Khuzestan province. Protecting about 80000 hectares of the downstream lands against the danger of destructive floods. Water diversion of the dam through the construction of the Dasht-e-Abbas pressure tunnel.

The average of released flow of different seasons for wet and dry years is shown in Fig. 3. According to this Figure, in all the periods, the highest released is occurred in summer and the lowest released is occurred in Fall. Considering the time model of

plantation and the major demand of agriculture compared to other demands, this process seems logical.  $b_1$ ,  $b_0$  values are shown in Fig. 4.

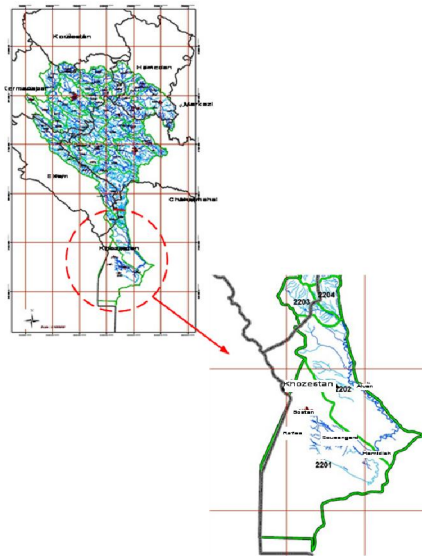

Fig. 2 Location of Karkheh reservoir system

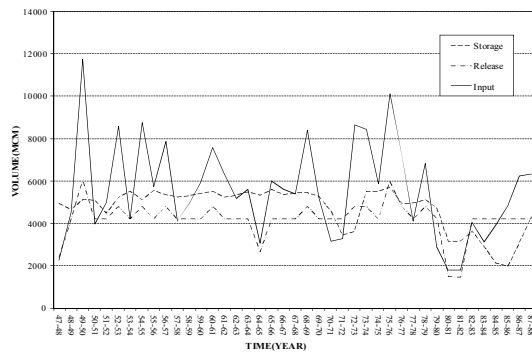

Fig. 3 The chart of input, storage and released flows of performing the program

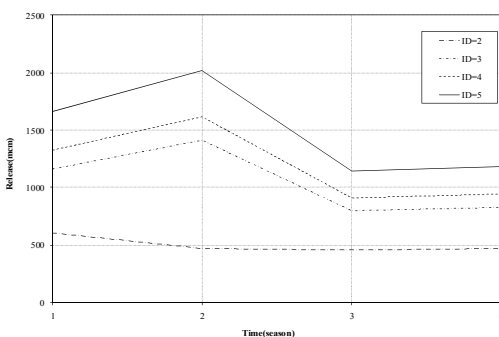

Fig. 4 The average reservoir released flow in different

periods

#### 4 Conclusion

In this paper to drive rule curve of a single storage system in Karkheh basin a genetic algorithm developed. In this model, the objective function is minimizing loss, considering the various inputs. Constraints that were in the reservoir, including constraints of reservoir continuity and constraints relating to volume, maximum and minimum operation and value of released. Decision variable is the amount needed to provide release. Results showed that 15% mutation rate with population of 100 chromosome, genetic algorithm has the best performance. The results of application of the model in total simulation period shows that, the maximum lack equivalent to 4.2% of the total simulation period and maximum surplus is equivalent to 2.2% of the total simulation period.

#### References:

- [1] Chang, F. Chen, L. Chang, L. Optimizing the reservoir operating rule curves by genetic algorithm, 2005, Hydrology process, Vol. 19
- [2] Chang, L. Chang, F. Wang, K. Dai, S. Constrained genetic algorithm for optimizing multi-use reservoir operation, 2010, Journal of Hydrology, Vol. 6, No.31
- [3] Esat, V. Hall, M. Water resources system optimization using genetic algorithm, 1994, 1st Int Conference Hydroinformatics, The Netherlands, Rotterdam, 225-231.
- [4] Hormavichian, R., Kangrang, A., Lamom, A., 2009, A Conditional genetic algorithm model for searching optimal reservoir rule curves, Journal of applied science, Vol. 9, No.19
- [5] Oliviera, A. Loucks, D. Operating rules for multi-reservoir systems, 1997, Water resources research, Vol. 33, No. 4.
- [6] Tung, C., Hsu, S., Liu, C., 2003, Application of the genetic algorithm for optimizing operation rules of the LiYuTan reservoir in Taiwan, American water resources association, Vol. 3, No.39.

10/6/2012

## The study of the effect of liquidity management on return on assets and return on rights of the share holders of the firms listed on Tehran stock exchange.

Alireza Zamanpour<sup>1</sup>, Shahroch Bozorgmehrian<sup>2</sup>

<sup>1</sup> Department of Accounting, Masjed Soleyman Branch, Islamic Azad University, Masjed Soleyman, Iran

<sup>2</sup> Department of Accounting, Masjed Soleyman Branch, Islamic Azad University, Masjed Soleyman, Iran

[Shahrokhbozorgmehryan@yahoo.com](mailto:Shahrokhbozorgmehryan@yahoo.com)

**Abstract:** the purpose of this research is to study the effect of liquidity management on return on assets and return on rights of the share holders of the companies listed on Tehran stock exchange. In order to test the hypothesized relationship between liquidity management and return on assets, data related to 92 companies listed on Tehran stock exchange, as statistical samples, have been analyzed in two methods including the analysis of the annual data and combined data for a period of time between the years 1382 to 1388. Also in studying experimental models of research, least-squares regression test was used. Results of the study have indicated that there is a positive meaningful relationship between liquidity management and return on rights share holders of the sample companies.

[Alireza Zamanpour, Shahroch Bozorgmehrian. **The study of the effect of liquidity management on return on assets and return on rights of the share holders of the firms listed on Tehran stock exchange.** *Life Sci J* 2012;9(4):1831-1835] (ISSN:1097-8135). <http://www.lifesciencesite.com>. 278

**Keywords:** liquidity management, return on assets, return on rights of the share holders, net profit

### 1- Introduction

When the liquidity analysis is discussed, information on cash flows statement is far more reliable than information on the balance sheet. The balance sheet data is static and measures the condition of the firm in a section of time, while the cash flows statement reports changes in other financial statements, and removes optional appropriations focusing on what share holders really care about.

Nowadays, industrial and service companies perform their production and business activities under the conditions that changes in business communities are fast and the level of competition is very high. Financial manager's ability in understanding and responding properly and quickly to the market condition and its changes is considered as an advantage of a firm.

In order for the managers to make decisions and conduct a business unit, they should be fully aware of different aspects and dimensions of the company's activity including liquidity management and assessment of the company's performance. Furthermore, common role of the financial reports based on information recorded in the accounts, the company's activity, efficiency as well as liquidity management. Shortage of liquidity means that the company (business) is unable to pay its debts and other commitments, which in turn can lead to forced sale and buy of the company's capital and asset. And even in more severe cases can lead to bankruptcy. Financial managers have realized that it will lead to the liquidity ratios of the company (such as current ratio, quick ratio and net working capital)- in terms of how much

capital cash is needed to be used in a certain time so as to meet the existing commitments (Jangwang,2002).

Liquidity management is an aspect of financial management which has attracted most of the time and attention of financial managers. Shortage of liquidity makes the company (business) unable to use the advantages of discounts or profitable factors. Liquidity management may seem very simple and elementary. But in fact credibility, esteem and success owe to strong liquidity management.

In fact if a company has a lot of cash but does not use it for investment, actually it won't have any efficiency. In other words, no more than the amount of cash and assets initially acquired by the company will be added. And may be faced with failure. In fact, liquidity by itself is not much important, rather as the oil makes the wheels of a car smoother, liquidity as well flow and accelerates the company's business activities.

Liquidity management, in fact is like a process based on which in emergent situations- the amount of grease needed for the company is prepared and controlled (Einabadi,1381).

Financial managers interfere directly in implementation of development plans which somehow affect the company's liquidity. This research significantly stresses the role played by liquidity management on performance results and returns in the stock, and by using the information of the listed companies in Tehran stock exchange, relatedness of operating cash flow, net profit accrual items. Historic current and instant ratios, and their anticipation power

have been studied. General purpose of this research is to liquidity management on return on assets and return on rights of the share holders of the listed companies in Tehran stock exchange. This study seeks for an answer to the following question : whether liquidity management can affect return on assets and return on rights of the share holders?

## 2- background of the research :

Various investigations have been done on this subject of interest at home and abroad. We mention some of them here.

(Jangwang2002) in his research studied the relation ship between liquidity management and performance results and value of the company in companies in Taiwan and Japan in a period of 11 years. Liquidity management of the companies implemented in there two countries has been different.

The results of his study indicated that there was a significant meaningful relationship between liquidity management and return on assets and return on rights of the share holds generally, severe liquidity management increases the performance results and value of the companies in both countries. In addition statistical results showed that liquidity management for overall Japanese and Taiwanese companies, which are divided based on type of industry, has been the minimum amount of liquidity in food industry and the maximum amount of liquidity in service industry.

The results of the study by wer them and (Rovinson1993) titled as "profit Vs cash flow" indicates that profit before extraordinary items and working capital due to operation, each one alone, are significant in describing changes in current ratio.

Also, measuring the additional information load of the accounting variables show that profit before extraordinary items describes the working capital due to the operation of the current ratio changes well. However, it does not offer cash flow form the operation of the additional information load related to the current ratio.

Hager (1986) indicates that companies a low liquidity cycle often have better performance results. He says that low liquidity cycle allows managers to minimize keeping non-profitable assets, and maintain the company's debt capacity. Also, low liquidity leads to the net value of the future cash flow of the company's assets.

Bowen et all(2001) studied the role of cash flow and accrual flows in decision making of the users of financial statements from two points of view. The results of their study showed that profits present a more powerful description than variable of cash flow, and also accrual accounting data have a more powerful description ability than cash flow.

Dechow (2002) studied the relatedness of accounting variable and the amount of the cash flow's

power of anticipation. He concluded that operating cash flow is a more appropriate standard for anticipating profits and inflows to a firm.

Gitman(2003) points out that there are limitations in the shares ratio, and recommends using the executive operation of cash conversion cycle (ccc) in analyzing liquidity. Since the concept of liquidity is re presented by the development, and harmony, and analysis of balance sheet on liquidity value, including measurement of the amount of income for the company's operating activities. Be rear et all (2002) studied the relatedness of cash component of earnings (profit) to the company's value.

Fran sice and chen(2005) cite in their research that the quality of the accrual items is the criteria on which the ambiguity about the company's future cash flow is distinguished. Kerr, sad ka , and sad ka(2011) in their study concluded that non-liquidity in the studied companies, have a meaningful relation ship with anticipation capability of future propits. In other words, problems of liquidity management in companies decrease the capability of anticipation.

Loffi sarikhani(1379) in his study, investigated the problem of liquidity and financial in companies in Mashhad stock exchange region and concluded that in the years1372.

1374 and 1376 measures taken to eliminate liquidity shortages did not have an effect on the total return of the companies.

But in 1373 , 1375 , financing the companies listed on Tehran stoke exchange has been effective in their total return.

## 3- variables of the study [re search]

Variables studied in this research include, liquidity management as an independent variable, and return on assets and return on rights of the share holders as independent variables. In addition, variable of debt ratio, company's size, and operating cash flow as control variables have been considered in this study.

### A- Dependant variable :

#### 1- return on assets :

As we mentioned above, in this study, return on assets is used as dependent variables. Return on assets is one the measurement criteria of the company's financial performance, and show how much output has been produced by the firm from it's total assets. This variable is obtained by dividing the net profit on total assets (Shaba hang, 1383. Tom et all, 2008).

$$*Equation(1) \rightarrow ROA = \frac{NI}{TA}$$

Here, Ni is net profit and TA represents total assets. Return on assets is one of the most important ratios which is obtained from the analysis of financial statements. Many financial analysts consider this ratio an important index to distinguish adequacy and

efficiency of the management in administering a business unit [firm].

## 2- Return on equities :

Another criterion for measuring performance in firms is return of equities, this variable is obtained by dividing net profit by total equities.

$$*Equation(2) \rightarrow ROA = \frac{NI}{TA}$$

Here in Eq(2), NI is not profit and e represents equity or total rights of the share holders, know as "equity" measures the profitability of each vial capital provided by share holders (Dastgir,1384)

## B- In de pendent variable : Liquidity management

:In this study, the independent variable is "liquidity management". Liquidity management is one of the aspects of financial management, which attracts most time and attention of financial managers. Shortage of liquidity makes the company unable to use discount advantages or profitable factors. Liquidity management may seem very simple and elementary. But in fact the company owes its credibility, esteem, and success to store liquidity management.

In fact if a company has a lot of cash, but it does not use it for investment actually it won't have any efficiency (Ein Abadi, 1381).

\*Equation(4)  $\rightarrow$  CCC=Inventory conversion period + Receivable conversion period- payable Deffered period.

Here in Eq(4), inventory conversion period is added to receivable conversion period, and payable deffered period is deducted form it.

This calculated variable indicates the liquidity management. the less this value is, mens that liquidity has been managed more properly (jangwang,2002).

Inventory conversion period (ICP), Receivable conversion period(RCP) , and payable deffered period(PDP)- respectively- are calculated as follow:

$$ICP = \frac{\frac{\text{Inventory at the beginning of the period} + \text{inventory at the end of the period}}{2}}{\frac{\text{cost of Goods sold}}{365}}$$

$$RCP = \frac{\frac{\text{Account receivable at the beginning of the period} + \text{account receivable at the end of the period}}{2}}{\frac{\text{sales}}{365}}$$

$$PDP = \frac{\frac{\text{Account receivable at the beginning of the period} + \text{account receivable at the end of the period}}{2}}{\frac{\text{cost of Goods sold}}{365}}$$

## C- Control variable :

Control variables are variable that may have an effect on dependent variable, however their study is not urgently needed. In this study, there variables have been used as control variables in regression model.

## 1- Debt ratio :

The first variable is debt, which is obtained from total debts de vided by total assets  $\left[ \frac{\text{total debts}}{\text{total assets}} \right]$  at the beginning of the current period (Fransice and chan,2005).

$$*Equation(5) \rightarrow DE_{it} = \text{DEBT}_{it} / A_{it}$$

## 2- company's size :

Company's size is calculated in the form of natural logarithm of total assets at the end of the period (jangwang,2003).

$$*Equation(6) \rightarrow \text{SIZE}_{it} = \log(A_{it})$$

## 3- Cash flow of operation [operating cash flow] :

Cash flow of operation that can be extracted from cash flow statement, is considered as the third control variable in this study.

## 4- Research hypo these :

Current research hypotheses- according to theoretical basics and background of the subject-include two hypotheses that have been developed as follow : first hypotheses : there is a meaningful relationship between liquidity management and return on assets.

Second hypotheses : there is a meaningful relationship between liquidity management and return on equities.

## 5- Statistical L community and sample :

Statistical community in this study includes all companies that have been listed on Tehran stoke exchange between the years 1382-1389 and maintained their membership during this period. The reason for easier and studying stoke firms is the possibility of easier access to financial reports of these firms and having more homogenous data due to the regulations of Tehran stoke exchange organization.

Total number of firms listed on Tehran stoke exchange amounts to 440 firms. The sampling method in this study is systematic elimination method. Based on this method, among all listed firms, the ones that are not eligible for any of the following conditions have been eliminated, and finally all remaining firms[companies] were selected for testing.

- Firms should have full information for all financial statements such as balance sheet, profit and loss statement, and cash flow statement.

- Their fiscal [financial] year should be ended in Esfand.

- Companies [firms] should be working on the stoke exchange during the time period of the research.

- Firms should not cange fiscal year during the period.

- Firms should not be the type of investment or brokerage.

- In this study, give to the mentioned limitations, 92 Firms have been selected and studied as samples.

## 6- Estimating model and testing of hypotheses :

In this study, according to the type of data and existing models of statistical analysis, econometric method of combined data (in the entire study period) has been used to estimate models of studying and investing hypotheses testing. In this study, quantitative value of independent and dependent variables - on one side- is related to 92 different firms, and on the other

side, Involves a period between the years 1382 to 1388.

Empirical model based on the research (Jangwang,2002) has been used to test research hypotheses, there for the first research hypothesis model has been formulated in the form of model(7) in order to study the relationship between liquidity management and return on assets :

$$* \text{ Equation(7)} \rightarrow \text{ROA}_{it} = a_0 + a_1 \text{CCC} + a_2 \text{DE}_{it} + a_3 \text{Fsize}_{it} + a_4 \text{CFO}_{it} + e_{it}$$

There in this model, CCC represents cash conversion cycle or period (independent variable) and ROA indicates return on assets (First dependent variable). DE, F size, and CFO represent debt ratio, company's size and cash flow of operation (control variable) respectively.

The second research hypothesis model is formulated in the form of model(8), so as to study the relation ship between liquidity management and return on equities :

$$* \text{ Equation(8)} \rightarrow \text{ROE}_{it} = a_0 + a_1 \text{CCC} + a_2 \text{DE}_{it} + a_3 \text{Fsize}_{it} + a_4 \text{CFO}_{it} + e_{it}$$

In this model, CCC represents cash conversion cycle or period (independent variable) and ROE indicates return on equities (second dependent variable). DE, F size, and CFO are debt ratio, firm size and cash flow of operation (control variable) respectively.

**7- the analysis of data and the results of hypotheses testing :**

In order to better understand the subject of study and learn more about the variables of the study, it's necessary to describe statistical data before analyzing them. Statistical description of data is step to identify the pattern dominating them and a base for explaining the relationship between the variables which are used in the study (Hafez nia,1389).

Therefore, before testing research hypotheses, we investigate descriptive statistics of variable used in the study. They are presented in table(1) :

\* Table (1) : Results of descriptive statistics of research variable :

CFO	SIZE	DE	CCC	RE	ROE	ROA	description
0/8191	5/5386	0/7450	4/3329	1/1158	1/1478	-14548	Average
0/1780	5/4671	0/7014	4/8201	3/5310	0/0146	0/0732	Middle
1/0187	0/5685	0/5879	2/8934	1/4695	0/0862	3/2960	Standard eviation
-0/9962	3/9554	0/0596	-1/6290	0/3383	0/3383	4/2059	Minimum
2/7755	7/8657	9/3774	12/3390	5/0953	0/9827	2/3485	Maximum

\* source : calculations by the researcher

In this study[research] the number of observations for each section is 92 observations (the number of sample firms), and includes a period of 7 years. In other words, the relationship between independent and dependent variables of the research on the side, among 92 different firms, and on the other

side, in a period of time between the years the 1382 to 1388 are tested.

Results of testing the first hypothesis for the years 1382 to 1388 in the form of data combination are described in table (2) :

\* table(2) : Results of testing the first hypothesis\* in combination level

confirm or veject the hypothesis	prod (F)	F- static	adjusted R- squared	R- squared	-p value	coefficient	description
confirmed	0/000	5/6623	0/5007	0/5252	0/0274	5/9912	CCC
					0/0221	-0/0494	DE
					0/0070	0/0249	F size
					0/1877	0/0185	COF

\* source : calculations by the researcher

According to the estimation results in combination form, statistic F become meaning in a confidence level of 99 per cents. in addition, coefficient CCC is positive and meaningful, which denotes direct relationship between liquidity management and return on assets. Thus, first hypothesis of the research is confirmed concerning this hypothesis are consistent with the results of the study by (Jangwang,2002), (Hager1986) and (Gitman2003).

In their study they too state that liquidity management has a meaningful relation ship with return on assets. Results of the second hypothesis for the years 1382 to 1388 in the 1388 in the form of data combination are described in table(3) :

\* table(3) : Results of testing second hypothesis

confirm or veject the hypothesis	prod (F)	F- static	adjusted R- squared	R- squared	-p value	coefficient	description
confirmed	0/000	23/4083	0/5693	0/5717	0/000	0/0699	CCC
					0/000	298/536	DE
					0/00050	188/360	F size
					0/000	-488/323	COF

\* source : calculations by the researcher

According to table (3), which is abut the estimation of model in the form of data combination, coefficient CCC is positive and meaningful. static F as wall is meaningful in a confidence level of 99 percent. There fore, second hypothesis that is a meaningful relationship between liquidity management and return on equities, is confirmed in a confidence level of 99 percent.

The results from testing this hypothesis are consistent with the results of study by (Jangwang,2002) and (Hager,1986).

**8- Conclusion and suggestion:**

Actual and potential investors need to anticipate future cash flows and return on firm's stoke in order to determine the value of their stoke and investment, and also decide the time to buy or sell them.

According to the results of this study, liquidity management in the firm-which is the responsibility of financial management- can have a big effect on return on stoke an profitability indexes. In this study, the relationship was tested empirically. The research hypothesis were studied by the method of analyzing combined data using a sample including 92 firms listed on Tehran stoke exchange and results of analyzing combined data of the research have confirmed first and second hypothesis.

In other words, results in an error level of 1 percent indicates that liquidity management in the studied firms had a positive and meaningful relationship whit return on assets and return equities as profitability indexes. performing any study or research opens way to new routes, and further study is needed to continue the way.

So, we suggest doing the following studies :

A- studying the relationship between liquidity management tools (other liquidity management measures) and other variables including the reported current year profit of the firms.

B- studying the effect of liquidity management on Firm's Future operating profits, and investigating the anticipation ability of these profits.

C- studying the effect of liquidity management on "return on assets" and return on equities divided into various industries and combining these industries.

D- Because firms have been required to issue the statement of cash flow since1381, and also we have used data inserted in this financial statements, so time territory of this study includes a short period.

There fore, it is recommended that study be done in future for longer periods period of time.

#### References :

- 1- (BozorgAsl 1384), Middle accounting, first volume, auditing organization, publication 175.
- 2- Tehran, Reza and (Noorbakhsh,Askar1388). Investment management compiled by P.Janes, Charles, Negah-e-Danesh publications, page 389-387.
- 3- (Saghafi, Ali and salami, Mohamadjavad1383). Fundamental variables of accounting and return on shares. Journal of social and human sciences of shiraz university, coures22, No 2 : page 61-74.
- 4- (Parsaeian, Ali 1387). System of investors in Tehran stoke exchange. Stoke exchange publication, No 5 , page4-18.
- 5- Janati, Mohamad Hassan (1381). Riddle of share price, stoke exchange publication, stoke exchange organization publications No 11.
- 6- Hafez Nia, Mohamad Reza. An introduction to research method in human sciences. Publication of the organization for studying and compiling human sciences university books (SAMT). 17<sup>th</sup> edition.
- 7- Daver zadeh, mahtab(1386). Studying big economic variables and their influences on the output of stoke firms. Master's Thesis.
- 8- Dastgir, Mohsen (1384). Basics of financial management. nor pardazan publication, first volume, second edition, (page 21-26).
- 9- Sajadi, Hassan. Principles book keeping and commercial accounting department of the national Iranian oil company, fifth volume, page276.
- 10- shabahang, reza(1383). Theory of accounting, first volume, third edition, center for specialized researches on accounting and audit, organization of audit.
- 11- talebi, mohammad(1382). Liquidity management. journal of financial research, year 3, No 11-12. Page 111-114.
- 12- Abdeh tabrizi, Hossein(1375) liquidity models, journal of power accounting, No 7, (page 9).
- 13- Aghili norri, susan-ali-sadat(1380). The study of liquidity condition in Tehran stoke exchange companies. Master's Thesis, mashhad Islamic Azad university.
- 14- Ein abadi, javad(1381). Liquidity management in big companies. Master's Thesis. Emam sadegh university.
- 15- Lotfi sarikhani, mohammad (1379). Problems of liquidity and financing in stoke companies [Firms] in Mashhad Region master's Thesis. Islamic Azad university of Mashhad.
- 16- Modarres, Ahmad and abdollah zadeh, farhad (1381). Financial management. business publications, first volume, first edition, page 256-260
- 17- Moor, carl and jadique, Robert (1376). Management accounting, translated by Hossin abdeh tabrizi and kamran azimzadeh, pishbord publication, third eition Mashhad.
- 18- Vakilifard, Hamid Reza, and vakilifrad, masoud (1380). Financial management. scientific publications of Fowj, First edition, mehr1380 , page 86-91.

**Results of Multilevel Anterior Cervical Discectomy and Cage Assisted Fusion without Plates**<sup>1</sup>Omar Kelany, <sup>2</sup>Ahmed Hashem Amin and <sup>3</sup>Mohamed Gamal<sup>1</sup>Orthopedic Department, Faculty of Medicine, Zagazig University, Egypt  
<sup>2</sup>Orthopedic Department, Faculty of Medicine, Al-Azhar University, Egypt  
[hashmdr@yahoo.com](mailto:hashmdr@yahoo.com)

**Abstract: Objective:** This prospective study was performed to evaluate the safety and efficacy of carbon fibre cages packed with demineralized bone matrix (DBM) mixed with autologous blood and curettage microchip material for treatment of multilevel cervical disc disease and spondylosis without the use of plates, screws or autogenous iliac crest bone graft. **Methods:** Twenty two patients underwent multilevel anterior cervical discectomy and fusion (ACDF). Fifteen patients underwent two level fusion and 7 patients underwent three level fusion; for a total 51 levels. Seventeen patients with cervical radiculopathy and three with radiculomyelopathy. Cervical lordosis and cervical fusion status was assessed on X-ray; and 20 patients also underwent computerized tomography (CT) to assess the results of surgery. **Results:** All the patients were followed clinically and radiologically with a mean of 24 months postoperatively (range 18-26 months). Radiculopathy improved after surgery in all the patients where's myelopathy resolved in three patients. The fusion rate was 96.1% in two level fusion and 93.3% in three level fusion. In two patients fusion was incomplete but reoperation was not required at the end of follow up period. No cage migration or cage failure occurred. **Conclusion:** ACDF using carbon fibre cage packed with DBM is a safe and efficient method for treatment of multilevel cervical disc disease and spondylosis. It preserves cervical lordosis and obviates the complications related to iliac crest graft harvest and screw plate fixation.

[Omar Kelany, Ahmed Hashem Amin, Mohamed Gamal. **Results of Multilevel Anterior Cervical Discectomy and Cage Assisted Fusion without Plates.** *Life Sci J* 2012;9(4):1836-1845] (ISSN:1097-8135).  
<http://www.lifesciencesite.com>. 279

**Keywords:** Cervical spondylosis, cervical discectomy, multilevel cervical fusion, cervical cage

**1. Introduction**

Anterior cervical discectomy and interbody fusion (ACDF) has proven to be a safe and effective procedure for the treatment of degenerative disc disease<sup>(1-5)</sup>. The anterior approach allows direct visualization of the entire interspace and wide decompression of the anterior aspect of cervical spinal cord and nerve roots and anterior inter body fusion may be performed if required<sup>(6)</sup>. The success rates decline in multilevel discectomies as the number of level increase<sup>(7, 8)</sup>. Graft collapse with the use of autogenous bone has been reported in 20-30% of multilevel fusion patients<sup>(9-12)</sup>. Moreover, even with solid fusion, kyphosis often develops in multilevel discectomies with autogenous iliac crest graft fusion<sup>(10-13)</sup>. Additionally, morbidity due to bone graft harvest remains high and can compromise the satisfactory clinical result of cervical nerve root and spinal cord decompression.<sup>(14-16)</sup>

Multilevel cervical discectomy is often combined with plate and screw fixation to maintain the spinal curvature, and increasing the graft fusion rate. However, plates and screws may cause complication such as screw breakage, screw pull out, esophagus perforation and spinal cord or nerve injury.<sup>(17-21)</sup>

The deficiencies mentioned above have favoured ongoing development of cage technology.<sup>(14, 15, 22)</sup>

Interbody fusion cages are hollow implant that restore the physiological disc height and lordosis, allowing bone graft growth within and around them, thus stimulating bone fusion. They have been developed to prevent disc space collapse with potential advantage of indirect foraminal decompression by restoration and preservation of intervertebral height and lordosis. In most studies, cages filled with autologous cancellous bone were used. Although this is likely to reduce graft harvesting complications, donor site pain still remain a common problem<sup>(23, 24)</sup>. The primary complications related to the implantation of fusion cages are subsidence into adjacent vertebral bodies (VBS), cage dislocation, nonunion – related instability and painful pseudoarthrosis<sup>(23-25)</sup>.

The purposes of this study were to evaluate the safety and efficacy of Carbon fiber cages packed with DBM (Crafton) mixed with autologous blood and curettage microchip material; for treatment of cervical degenerative disc disease and their application in multilevel surgery without the addition of an anterior plate system and to determine if it is possible to eliminate donor site complications and to



achieve good outcomes for multilevel discectomy and fusion.

## 2. Patients and Methods:

In Orthopedic Department, Zagazig University hospital, between February 2006 and September 2010, 22 patients (14 women and 8 men) suffering from degenerative disc disease underwent ACDF using carbon fibre cage packed with DBM (Grafton) mixed with autologous blood and curettage microchip material. Fifteen patients underwent two level fusion and 7 patients underwent three level fusion for a total of 51 levels. No plate instrumentation was used. The mean age was 43 years range (35-60 years). There were seventeen patients with cervical radiculopathy and five patients with radiculomyelopathy. There were 10 patients with kyphotic deformity of the cervical spine. (**Table 1**)

Indication for operation was intractable radiculopathy, and radiculomyelopathy due to nerve root or spinal cord compression and compatible magnetic resonance imaging (MRI) findings. Patients with trauma, infection and neoplasms were excluded. Conforming to international ethical standard, all patients were given detailed information on the operation, the follow-up protocol and radiological investigations and their consent was obtained.

The operative procedure was performed as described by Robinson and Smith<sup>(26)</sup>. The disc, posterior longitudinal ligament, and osteophytes, including the posterior part of the uncinat process were removed endplate cartilage was also removed with a high speed drill and curette. Curettage microchip material was conserved. Cages were inserted into the disc space after packing with DBM mixed with autologous blood and curettage microchip material.

The wound was closed with re-approximation of anatomic planes over a suction drainage system. All patients wore a Philadelphia collar for 6 weeks after surgery and 14 patients received physiotherapy after removal of the collar.

Clinical and radiological follow-up was performed at the 3<sup>rd</sup>, 6<sup>th</sup>, 12<sup>th</sup> and 24<sup>th</sup> months postoperatively. In addition to standard neurosurgical examination, we evaluated spinal curves, mobility and fusion status with X-ray was evaluated. Four views of X- ray were used, including anterior posterior, neutral and flexion and extension lateral views (Figs 1, 2).

### Criteria of Evaluation:

At the end of follow up 24 months range (18-26 months), the following criteria were used to judge the success of surgery: recovery of neurological function, absence/presence and intensity of neck pain, extent of fusion on cervical X-ray films, degree of spinal

curvature on X- ray films, position of the cage, and return to work.

The operation segment was deemed to be fused if there was no change in position of levels on dynamic views (flexion and extension).

Fusion was considered complete if the endplates had disappeared into both adjacent VBs and if the two VBs formed a block with no radiolucency demonstrated except by the cage itself.

Lateral X-ray films were performed to evaluate the spinal curve pre and postoperatively. The Ishihara curvature index (ICI) was used for this evaluation<sup>(27)</sup>. A straight line was drawn from the posterior border of the dens to the posterior border of the C7. Another line was drawn from the posterior border of C4 perpendicular to the first line, in which the intersected length was measured in millimeters as the degree of spinal curvature. A positive intersected length indicates the degree of lordosis. If the intersected length is negative it indicates kyphosis. When the intersected length is zero, the spinal curve is referred to as straight.

## 3. Results:

None of the patients suffered neurological deterioration, and there were no major complications during immediate post-operative period; postoperative X-ray confirmed appropriate positioning of the vertebral cages.

### Recovery of neurological function:

All patients suffering from radiculopathy improve gradually after surgery; except one patient was still complaining of mild sensory loss at 1 year follow up. Of the five patients with radiculomyelopathy the radicular dysfunctions resolved in all five where's myelopathic dysfunctions resolved in three patients only.

### Fusion rate:

At final follow up, 14 (93.3%) of the 15 patients surgically treated with two levels fusion, and 29 (96.6%) of 30 levels showed complete radiological fusion i.e. one patient with one incomplete fusion level.

Also 6 (85.7%) of 7 patients surgically treated for three level fusion and 20 (95.2%) of 21 levels, showed complete radiological fusion i.e one incomplete fusion level in one patient with three level fusion). Totally: 49/51 levels (96%) showed complete fusion (**Table 2**).

In those two patients where the fusion was incomplete; this was confirmed on follow up C.T. studies. Those two patients complained of mild neck pain but exhibited no symptoms of pseudoarthrosis. Imaging showed no cage failure or dislodgement. Reoperation for non-fusion was not necessary in

addition, no mobility was seen on dynamic x- ray films at any operated segments.

#### Neck pain:

Post operatively. The mean visual analog pain score was (VAS) 3.2 (range 1-6) compared with a preoperative score of 8.2 (range 7-10), the difference was statically significant ( $P < 0.01$ )

#### Spinal curvature:

The kyphotic deformity was corrected in nine of ten patients. No case of iatrogenic cervical deformity was observed postoperatively.

#### Cage positioning:

No patient with cage extrusion was observed. In three levels, cage settling inside the disc end plate were observed with no evidence of symptoms recurrence or iatrogenic kyphosis in any of these patients.

#### Return to work:

All patients who suffered preoperatively from radiculopathy improved after surgery and returned to their preoperative jobs, except for one patient with moderate radiculopathy who had obliged to change to occupations requiring milder activity. In one patient in whom myelopathic dysfunction did not improve after surgery had not returned to work at 24 months follow up (Table 3).

#### Complication:

None of the patients suffered major complications or neurological deterioration. There were two cases of dysphagia however this resolved in two weeks there was. One patient with transient vocal cord dysfunction and there one patient with superficial wound infection treated successfully with antibiotics (Table 4).

Table (1): Patients demographic data.

	N = 18	
Age (years)		
$\bar{x} \pm SD$	43 $\pm$ 6.7	
Range	35-60	
Gender		
Men	8	36.6%
Women	14	63.4%
Operative data		
Patient with radiculopathy	17	77.3%
Patient with radiculomyelopathy	5	22.7%
Patients with pre-operative kyphosis	10	45.4%
Patients with two level fusion	15	68.2%
Patients with three level fusion	7	31.8%
Follow up period (months)	24 $\pm$ 4.4	
	Range (18-26)	

Table (2): Post-operative fusion rate.

Fusion rate	Patient N	Fused level (N)
Two level fusion	15	30
Solid fusion	14 (93.3%)	29 (96.6%)
Three level fusion	7	21
Solid fusion	6 (85.7%)	20 (95.2%)
Total fusion rate	18/20 (90%)	49/51 (96%)

Table (3): Post-operative results

	(X $\pm$ SD)	(Range)
Neck pain (VAS)		
Pre – operative	8.2 $\pm$ 0.5	(7-10)
Post- operative	3.2 $\pm$ 1.4	(1-6)
Kyphosis		
Pre- operative	10/22	(45.4%)
Post- operative	1/22	(4.5%)
Recovery of neurological function		
Radiculopathy improvement	16/17	94.1%
Mild sensory loss	1/17	5.8%
Complication		
Dysphagia	2	9%
Vocal cord dysfunction	1	4.5%
Superficial wound infection	1	4.5%

$P < 0.001$  when compare with pre-operative

Table (4): Results at final follow up.

	Age	Sex	Complain	Level	Kyphosis Pre. op.	Lordosis post. op.	Fusion	Complications
1	48	♂	Radiculopathy	C3-4, C4-5	-	+ ve	+ve	
2	50	♀	Radiculopathy	C3-4, C4-5	+	+ ve	+ ve	
3	35	♀	Radiculopathy	C4-5, C5-6	-	+ ve	+ ve	
4	54	♂	Radiculopathy	C4-5, C5-6	+	+ ve	+ ve	Mild sensory loss
5	37	♂	Radiculopathy	C4-5, C5-6	-	+ ve	+ ve	Vocal cord dysfunction
6	40	♂	Radiculopathy	C4-5, C5-6	+	+ ve	+ ve	
7	50	♀	Radiculopathy	C4-5, C5-6	-	+ ve	+ ve	
8	54	♀	Radiculopathy	C5-6, C6-7	-	+ ve	+ ve	Superficial wound infection
9	60	♂	Radiculopathy	C5-6, C6-7	-	+ ve	+ ve	
10	60	♂	Radiculopathy	C5-6, C6-7	-	+ ve	+ ve	
11	56	♀	Radiculopathy	C5-6, C6-7	-	+ ve	+ ve	
12	54	♀	Radiculomyelopathy	C5-6, C6-7	-	+ ve	One level fusion only	
13	60	♀	Radiculopathy	C5-6, C6-7	-	+ ve	+ ve	Dysphagia
14	58	♀	Radiculopathy	C5-6, C6-7	+	+ ve	+ ve	
15	57	♀	Radiculopathy	C5-6, C6-7	+	+ ve	+ ve	
16	52	♂	Radiculomyelopathy	C 3,4, C4,5 C5,6	-	+ve	Two level fusion only	Myelopathy
17	40	♀	Radiculomyelopathy	C 3,4, C4,5 C5,6	-	+ve	Two level fusion only	Myelopathy
18	48	♀	Radiculomyelopathy	C4,5 C5,6, C 6,7	+	- ve	+ve	Myelopathy
19	58	♀	Radiculomyelopathy	C4,5 C5,6, C 6,7	+	- ve	+ve	Myelopathy
20	52	♂	Radiculopathy	C4,5 C5,6, C 6,7	+	+ ve	+ ve	Dysphagia
21	50	♀	Radiculopathy	C4,5 C5,6, C 6,7	+	+ ve	+ ve	
22	60	♀	Radiculopathy	C4,5 C5,6, C 6,7	+	+ ve	+ ve	

**Case I**

Pre- operative A.P x- ray



Pre- operative lateral view x- ray



Pre-operative lateral extension x-ray



Pre-operative lateral flexion x-ray



Pre-operative M.R.I

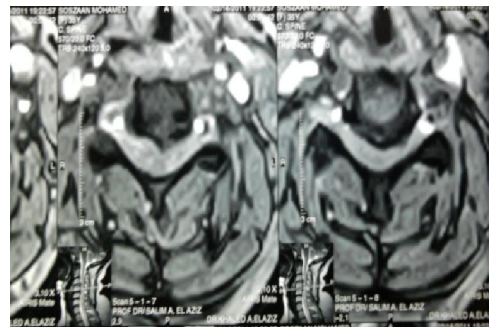

Pre-operative M.R.I

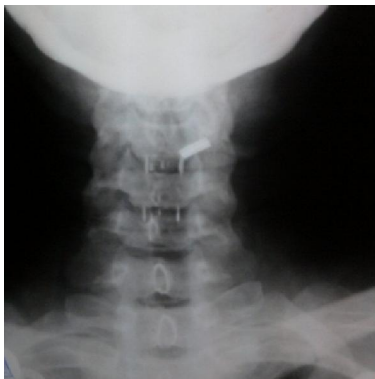

6 months post – operative



6 months post – operative



1 year post – operative



1 year post- operative



18 months post-operative extension



18 months post-operative flexion

**Case (I):** Male patient 30 year with radiculopathy C4,5/C5,6, MRI cervical disc prolapse C4,5/C5,6, Two level fusion, solid fusion

**Case II**



Pre- operative A.P. x- ray



Pre-operative lateral x- ray



Pre-operative sagittal M.R.I

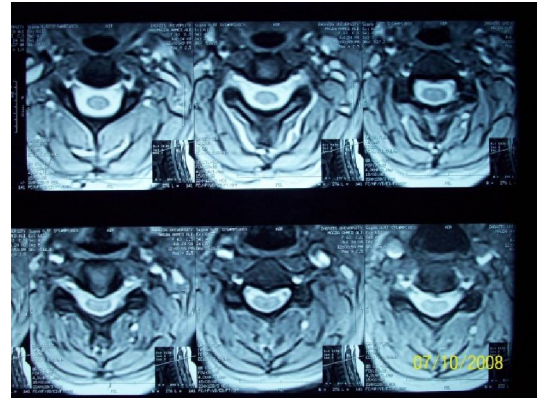

Pre-operative coronal M.R.I



3 months post- operative



3 months post – operative



12 months post- operative



12 months post-operative

**Case (II):** Female patient 54 year, Radiculopathy C4,5/ C5,6,  
MRI cervical disc prolapse C4,5/C5,6  
Two level fusion, follow up: solid fusion

#### 4. Discussion:

Anterior cervical discectomy and interbody fusion is an efficacious procedure used to treat a variety of cervical spinal disorders, including spondylosis, myelopathy, herniated discs, trauma, and degenerative disc disease. The success of this procedure relies on thorough decompression and development of a solid osseous fusion.<sup>(1-5, 25, 27, 28)</sup>

Brown *et al.*<sup>(29)</sup> reviewed serial X-rays after anterior cervical fusion performed in total of 139 levels in 98 patients and found arthrodesis in 97% of patients who underwent auto-graft procedures. In their series, Savolainen *et al.*<sup>(30)</sup> found a 98% fusion rate in patients who underwent procedures with auto-graft. According to the results obtained from other series, for single-level discectomy with autogenous bone fusion, ACDF can achieve a 92-100% fusion rate<sup>(20)</sup> and 70-90% neurologic and symptomatic improvement.<sup>(4,5)</sup> Although, arthrodesis with autologous iliac crest graft is considered as the biological and biomechanical standard in anterior cervical reconstruction,<sup>(9,31)</sup> the morbidity of the iliac bone harvest can often tarnish these results.<sup>(3, 15, 23-25, 28, 30, 32-34)</sup> Silber *et al.*<sup>(15)</sup> observed that 26.1% of patients reported pain at the donor site. Summer *et al.*<sup>(24)</sup> also reported chronic pain in the donor site in 25% of 290 patients. According to Arrington *et al.*<sup>(14)</sup>, in addition to the minor complications of the donor site (superficial infections, hematoma, cosmetic problems, etc.) there were major complications in 5.8% of cases, requiring therapeutic modifications, surgical revision and prolongation of hospitalization. Castro *et al.*<sup>(1)</sup> reported a donor site complication rate of 22% in their series. In this study, the donor site morbidity was avoided.

In the Cloward procedure, the best results have been reported for young male patients with soft disc disease, at the single level.<sup>(35, 36)</sup> Multilevel anterior cervical discectomy and fusion still remains a difficult problem. Autogenous bone does not maintain spinal instability in multilevel discectomy very well and the graft complication rate in autogenous bone graft in multilevel fusion is higher than at the single level.<sup>(3,8, 9,13)</sup> Graft collapse with autogenous bone is reported in 20-30% of multilevel fusion<sup>(10-12)</sup>. Moreover, it has been reported this even with solid fusion, kyphosis often develops in multilevel discectomies with autogenous iliac crest graft fusion<sup>(10-17)</sup>. The literature also reports a consistent rate of 10-12% non-fusion for single-level anterior discectomy and autogenous bone fusion, 20-27% for two-level, and approximately 30-56% for three-level fusions<sup>(7-9)</sup>. It is clear that the success rates decline as the number of level increase.

In the light of these reports, in multilevel ACDF procedures, augmentation with plate fixation, may

seem to be preferable. Plate fixation may decrease the micromovement of the cervical spine, enhance the fusion rate, and correct spinal curve to physiological lordosis.<sup>(6,15)</sup> In ACDF, additional plate fixation has been reported to result in a higher fusion rate, lower reoperation rate, and better pain relief<sup>(9,12,13,31)</sup>. However, in their retrospective study, Das *et al.*<sup>(13)</sup> studied 38 patients who had arthrodesis with cylindrical titanium cages filled with autologous bone graft harvested from the operative site and screw-plate fixation, and they reported the rate of pseudoarthrosis was 6-8% for one-level and 15-46% for treatment of several levels. Overall in three and four-level discectomies the successful fusion rate decreases 18-82%, even when a cervical spine locking plate is used.<sup>(37-39)</sup> Moreover, plate complication rate varies from 2.2-24%<sup>(20,34)</sup> and includes screw pullout,<sup>(21,40)</sup> screw breakage,<sup>(21)</sup> injury of the laryngeal nerve,<sup>(8)</sup> injury of oesophagus<sup>(19)</sup> injury of spinal cord or root, injury of vertebral artery, and wound infection.<sup>(21)</sup> Additionally, the operative time is usually longer.

These complications of classical fusion procedures favoured ongoing development of cage technology. Because of the advantages of these devices, the use of cages in ACDF operations has been increasing in popularity. In parallel with this, there are several different types of interbody fusion cages commercially available.<sup>(22-23,33)</sup> Cage assisted ACDF has proved to be a safe and effective procedure for the treatment of degenerative disc disease. It has been reported that the cage achieves excellent fusion rates ranging from 95.2-100%<sup>(2,25,28,32,33,40,41)</sup>. In this study, the fusion rate was 96.6% in two levels fusion and 93.3% in three levels fusion, counted by levels of X-ray comparable to the related literature. There were two patients with incomplete fusion, however, no clinical signs or radiographic mobility of pseudoarthrosis were observed during the follow-up period and reoperation was not necessary.

In this study, no cage failure or migration was encountered, even in patients who underwent fusion at more than two levels. The use of the cage was found to preserve the spinal lordosis and the height of the foramina. Bartels *et al.* reported that the cervical cage effectively increased foraminal height even after 1 year which contributed to decompression of the nerve root.<sup>(42)</sup> The wedge shape of the device may contribute to restoration of lordosis. Furthermore, the cage structure (two carbon fibers spikes on the upper and bottom frame, in addition to the retention teeth on the surface of the upper and bottom frame) offers a fixation mechanism which is similar to the functions of plate and screws.<sup>(28,33)</sup> Additionally, bone fusion can be evaluated easily by examining X-rays,

because the cage is radio-transparent. It is also possible to evaluate postoperative MRI or CT scans, because artifacts are negligible.

To minimize the extent of surgery, and to avoid donor site complications, the cage was filled with DBM mixed with autologous blood and microchips of curettage material. The surgical results presented in this study are encouraging and provide an impetus to the use of interbody cage rather than a ventral cervical plate for structural support in the management of multilevel degenerative cervical disc disease.

#### Conclusion:

Interbody fusion with cages packed with DBM, and autologous blood and microchips of curettage material is a safe and effective procedure in the treatment of multilevel cervical disc disease. It preserves spinal lordosis, and obviates the complications related to graft harvest and screw plate fixation.

#### Corresponding authors

##### Ahmed Hashem Amin

Orthopedic Department, Faculty of Medicine,  
Zagazig University, Egypt  
[hashmdr@yahoo.com](mailto:hashmdr@yahoo.com)

#### References:

- 1- Castro FP, Holt PT, Majd M, Whitecloud TS. A cost analysis of two anterior cervical fusion procedures. *J Spinal Disord* 2000; 13:511-4.
- 2- Cauthen JC, Kinard RE, Vogler JB. Outcome analysis of non-instrumented anterior cervical discectomy and interbody fusion in 348 patients. *Spine* 1998; 23: 188-92.
- 3- Heidecke V, Rainov NG, Marx T, Burkert W. Outcome in Cloward anterior fusion for degenerative cervical spinal disease. *Acta Neurochir (Wien)* 2000; 142: 283-91.
- 4- Sampath P, Bendebba M, Davis JD, Ducker TB. Outcome in patients with cervical radiculopathy: prospective, multicenter study with independent clinical review. *Spine* 1999; 24: 591-7.
- 5- Sampath P, Bendebba M, Davis JD, Ducker TB. Outcome of patients treated for cervical myelopathy: a prospective, multicenter study with independent clinical review. *Spine* 2000; 25: 670 – 6.
- 6- Sonntag VKH, Klara P. Controversy in spine care. Is fusion necessary after anterior cervical discectomy? *Spine* 1996; 21: 1111-1113.
- 7- Eck KR, Lenke LG, Bridwell KH, Gilula LA, Lashgaric CJ, Riew KD. Radiographic assessment of anterior titanium mesh cages. *J Spinal Disord* 2000; 13: 501-10.
- 8- Emery SS, Fisher RS, Bohlman HH. Three- level anterior cervical discectomy and fusion. *Spine* 1997; 22: 2622-5.
- 9- Zdeblick TA, Ducker TB. The use of freeze-dried allograft bone for anterior cervical fusions. *Spine* 1991; 16: 726-9.
- 10- Katsuura A, Hukuda S, Imanaka T, Miyamoto K, Kanemoto M. Anterior cervical plate used in degenerative disease can maintain lordosis. *J Spinal Disord* 1996; 9: 470-6.
- 11- Shapiro S. Banked fibula and the locking anterior cervical plate in anterior cervical fusions following cervical discectomy. *J Neurosurg*, 1996; 84: 161-5.
- 12- Shapiro S, Connolly P, Donaldson J, Abel T. Cadaveric fibula, locking plate, and allogenic bone matrix for anterior cervical fusion after cervical discectomy for radiculopathy or myelopathy. *J Neurosurg Spine* 2004; 1: 160-7.
- 13- Das K, Couldwell WT, Sava G, Taddonio RF. Use of cylindrical titanium mesh and locking plates in anterior cervical fusion. *J Neurosurg* 2000; 94 (Suppl. 1): 174-8.
- 14- Arrington ED, Smith VJ, Chambers HG, Bucknell AL, Davino NA. Complications of iliac crest bone graft harvesting. *Clin Orthop* 1996; 329: 300-9.
- 15- Silber JS, Anderson DG, Daffiner SD. Donor site morbidity after anterior iliac crest bone harvest for single-level anterior cervical discectomy and fusion. *Spine* 2003; 28: 134-9.
- 16- Smith GW, Robinson RA. The treatment of certain cervical spine disorders by anterior removal of the intervertebral disc and interbody fusion. *J Bone Joint Surg Am* 1958; 40A: 607 – 23.
- 17- Colak A, Kutlay M, Tosyali L, Demircan M. Three level cervical discectomy and fusion without internal fixation. *Turkish Neurosurg* 2000; 10:126-30.
- 18- Eleraky M, Lianos C, Sonntag VKH. Cervical corpectomy: report of 185 cases and review of literature. *J Neurosurg (Spine 1)* 1999; 90: 35-41.
- 19- Hanci M, Toprak M, Sarioglu AC. Esophageal perforation subsequent to anterior cervical spine screw/ plate fixation. *Paraplegia* 1995; 33: 606-9.
- 20- Kaiser MG, Haid RW, Suback BR, Barnes B, Rodts GE Jr. Anterior cervical plating enhances arthrodesis after discectomy and fusion with cortical allograft. *Neurosurgery* 2002; 25: 229-35.
- 21- Kostuik JP, Connolly PJ, Esses SI, Suh P. Anterior cervical plate fixation with the titanium hollow screw plate system. *Spine* 1993; 18: 1273-8.
- 22- Matge G. Cervical cage fusion with five different implants: 250 cases. *Dur Spine J* 2003; 12: 513-6.



- 23- Rawlinson JN. Morbidity after anterior cervical decompression and fusion: The influence of the donor site on recovery, and the results of a trial of Surgibone compared to autologous bone. *Acta Neurochir.*, 1994; 131: 106-18.
- 24- Summers BN, Eisenstein SM. Donor site pain from the ilium. A complication of lumbar spine fusion. *J Bone Joint Surg (Br)* 1989; 71 (4): 677-80.
- 25- Vavruch L, Hedlund R, Javid D, Leszniewski W, Shalabi A. A prospective randomized comparison between the Cloward procedure and carbon fiber cage in the cervical spine. *Spine* 2002, 27: 1694-701.
- 26- Robinson RA, Smith GW. Anterolateral cervical disc removal and interbody fusion for cervical disc syndrome. *Bull Johns Hopkins Hosp.*, 1955; 96: 233-4.
- 27- Ishihara A. Roentgenographic studies on the normal pattern of cervical curvature. *Nippon Seikei Geka Gakkai Zasshi* 1968; 42: 1033-44.
- 28- Cho DY, Lee WY, Sheu PC. Treatment of multilevel cervical fusion with cages. *Surg Neurol.*, 2004; 62: 378-85.
- 29- Brown MD, Malinin TI, Davis PB. A roentgenographic evaluation of frozen allografts versus autografts in anterior cervical spine fusions. *Clin Orthop* 1976; 119: 231-6.
- 30- Savolainen S, Rinne J, Hernesniemi J. A prospective randomized study of anterior single-level disc operation with long-term follow-up. Surgical fusion is unnecessary. *Neurosurgery* 1998; 43: 51-5.
- 31- Williams A, McNamara RM. Potential of polyetheretherketone and carbon fiber reinforced PEEK in medical applications. *J. Mater Sci let.*, 1987; 6: 188-90.
- 32- Matge G. Anterior interbody fusion with the BAK- cage in cervical spondylosis. *Acta Neurochir (Wien)* 1998; 140-1-8.
- 33- Cho DY, Liau WR, Lee WY, Liu JT, Chiuc L, Sheu PC. Preliminary experience using a polyetheretherketone (PEEK) cage in the treatment of cervical disc disease. *Neurosurgery* 2002; 51: 1343-50.
- 34- Wang JC, McDonough PW, Endow KK, Delamater RB. Increased fusion rates with cervical plating for three- level anterior cervical discectomy and fusion. *Spine* 2001; 26: 643-7.
- 35- Bertalanffy H, Eggert HR. Clinical long-term results of anterior discectomy without fusion for treatment of cervical radiculopathy and myelopathy: a follow up of 164 cases. *Acta Neurochir.*, 1988; 90: 127-35.
- 36- Eriksen EF, Buhl M, Fode K. Treatment of cervical disc disease using Cloward's technique: the prognostic value of clinical preoperative data in 1.106 patients. *Acta Neurochir.*, 1984; 70:181-97.
- 37- Bishop RC, Moore KA, Hadley MN. Anterior cervical interbody fusion using autogenic and allogenic bone graft substrate: a prospective comparative analysis. *J. Neurosur.*, 1996; 85: 206-10.
- 38- Bolesta MJ, Rehtine GR, Chrin AM. Three- and four-level anterior cervical discectomy and fusion with plate fixation: a prospective study. *Spine* 2000; 25: 2040-6.
- 39- Wang JC, McDonough PW, Endow KK, Delamater RB. A comparison of fusion rates between single-level cervical corpectomy and two-level discectomy and fusion. *J Spinal Disord.*, 2001; 14: 222-5.
- 40- Profeta G, Falco R, Ianniciello G, Profeta L, Cigliano A, Raja AI. Preliminary experience with anterior cervical microdiscectomy and interbody titanium cage fusion (Novus CT-Ti) in patients with cervical disc disease. *Surg Neurol.*, 2000; 53:417-26.
- 41- Steffen T, Tsantrizos A, Fruth I, Aebi M. Cages: designs and concepts. *Eur Spine J* 2000; 9 (Suppl. 1) 89-94.
- 42- Bartels RH, Donk R, van Azn RD. Height of cervical foramina after anterior discectomy and implantation of a carbon fiber cage. *J Neurosurg* 2001; 94 (Suppl. 1): 40-2.

8/29/2012