

# CONTENTS

382	<b>A Comparative Study of the extent of President's Responsibility for his Legal Assignments in Iran, France and America</b> Ebadollah Abbasi and Khalegh Masoudi	2629-2632
382	<b>Quality of life, its early change and retention in MMT program in Iran: Evidence for policymakers and service providers</b> Samad Rouhani, Farzan Kheirkhah, Iraj Salarieh, Saleh Abedi	2633-2638
384	<b>A New Technique for Measuring Human Stress Level</b> Reza Alipour , Mohammad Reza Iranpour	2639-2646
385	<b>Investigation of the upper Khamiformationsin MahshahrNo.1 well and Hendijan No.6 well with use of well logging</b> FatemehAbedini , JavadTabatabaei , Ali Amiri	2647-2652
386	<b>Stones of British Colonial Lahore: A study of two Remarkable Buildings of earlier period of British Colonial Architecture</b> Arif Khan, Sabahat Arif , Abdul Rehman and Khalid Alamgir	2653-2659
387	<b>Evaluation of the impact of hospitality on tourism development with emphasis on Iran</b> Sima Hemmati	2660-2666
388	<b>Comparing the role of the middle class in political development (democracy) of Turkey and Saudi Arabia</b> Abbas kaabi	2667-2674
389	<b>America and Russia oppositions in middle Asia after eleven September</b> Mahdi Nouri	2675-2679
390	<b>Comparison the policies of west (United States America and NATO) and East (Russia and Shanghai) in the Middle Asia</b> Ali Hamid	2680-2685
391	<b>Feudalism in Iran</b> Zia Khazaei	2686-2690
392	<b>The Economic Analysis and Evaluation of the Investment projects with special References to the fuzzy Approach</b> Ali Flahati , Rahman Mirzaeian	2691-2695
393	<b>Use of the <i>cdt</i> gene specific PCR in determining virulence properties of <i>Campylobacter jejuni</i> isolated from chicken meat samples obtained in some supermarkets in Mafikeng, NWP, South Africa</b> Masego Montwedi and Collins Njie Ateba	2696-2701
394	<b>Detection of Avian Influenza (H5N1) In Some Fish and Shellfish from Different Aquatic Habitats across Some Egyptian Provinces</b> A.E. Eissa , H .A. Hussein and M.M. Zaki	2702-2712
395	<b>Studies on Detoxification of Aflatoxins Contaminated Rabbits' Rations Treated with Clay and Ammonia</b> Helal S.H. Abu-EL-Zahab Ahmed Abdel Aziz Baiomy and Dalia Yossri Saad	2713-2721

- 396 **Use of Waves and Tide Energy for Production Electricity in Iran** 2722-2725  
Nafiseh Ghorbani, Amrollah Moradi, Heidar Abdollahian and Mohammad Ranjbar Kohan
- 397 **The theory of mind in terms of Sheykh Ishraq:** 2726-2729  
Zeinab Sagvand
- 398 **False belief about etiology of cancer** 2230-2232  
Ali M. Al-Amri, MD
- 399 **The Evaluation of Right Atrial Temporary Pacing for Preventing Postoperative Atrial Fibrillation Following Coronary Artery Bypass Grafting Surgery: prospective observational study** 2233-2237  
Abbasi Tashnizi Mohammad , Moeinipour Ali Asghar , Mirzai Asadollah, Asadollah Jalal , Sadraee Javad , Sepehri Shamloo Alireza, Zirak Nahid, Khameneh Bagheri Ramin, Amouzeshe Ahmad
- 400 **Tiny Circularly Polarized Printed Slot Antenna for UWB Usage** 2238-2241  
Majid Shokri , Ch. Ghobadi and J.Nourinia , Hamed Shirzad, S.Asiaban and Zh.Amiri
- 401 **Microleakage Evaluation of Two Different Nano-Restorative Materials in Primary Molars: *In Vitro* Study** 2242-2250  
Eman A. El-Ashiry; Niveen S. Bakry; Najat Farsi and Deema Farsi
- 402 **Nerve Conduction Velocity of Sciatic Nerve in High Fat Diet Induced Obesity in Rats: Effect of Corn Oil and Omega 3 Fatty Acids Supplement** 2251-2264  
Laila Ahmed El sayed, Samah Elattar, and Nashwa Eltablawy
- 403 **Change Management Challenges in Nursing and Midwifery Schools: A qualitative study of managerial experiences** 2265-2269  
Alice Khachian, Houman Manoochehri, Mehrnoosh Pazargadi, Safar Ali Esmacili Vardanjani
- 404 **Use Of Fuzzy Logic For Risk/Benefit Assessment In Medical/Biological Cases** 2270-2273  
Mariam K Hafshejani, Manochehr Sattari Naeini, Aboosaleh Mohammadsharifi, Mohammadtaghi Yahiapoor, Ameneh Langari
- 405 **Role of Magnesium ion in neonatal jaundice** 2274-2278  
Abdel hakeem Abdel mohsen, Mohammed F Afify, Emad Allam and Hedaya Abdelkarem

## A Comparative Study of the extent of President's Responsibility for his Legal Assignments in Iran, France and America

Ebadollah Abbasi<sup>1\*</sup> and Khalegh Masoudi<sup>2</sup>

<sup>1</sup> Department of Law and Political Sciences, Abadeh Branch, Islamic Azad University, Abadeh, Iran.

<sup>2</sup> MSc student, Department of private law, Abarkouh Branch, Islamic Azad University, Abarkouh, Iran

\*Corresponding author: [abassi272@yahoo.com](mailto:abassi272@yahoo.com)

**Abstract:** One of the aspects of government's accountability pro rata the president's accountability and responsibility is related to political accountability and that is the government or executive officials of the land must be accountable for parliament and people regarding their policies, and also priority and the state of executing them. Unlike legal accountability having relatively simple connections and just a connection between governmental authorities and courts, political accountability has more complicated structure. In such accountability, governmental non-elective organs (e.g. public services, armed forces, police, and security services) through ministers appointed by the president are held accountable for him. In turn, the presidents and ministers are also accountable for people and parliament or legislative considered as people's representatives. Another aspect of the president or government's accountability is legal or juridical accountability. In explaining such responsibility, it must be said that all governmental officials including the elective and appointive are accountable for courts in case of any violation in their functions. Basically, the concept of law government is also innate in here and, that is, those who implement rules and execute policies themselves must act based on the power determined and limited by law and also according to constitution. In this article, we intend to study and compare the president's responsibility in three countries: Iran, America, and France.

[Ebadollah Abbasi and Khalegh Masoudi. **A Comparative Study of the extent of President's Responsibility for his Legal Assignments in Iran, France and America.** *Life Sci J* 2012;9(3):2629-2632] (ISSN:1097-8135). <http://www.lifesciencesite.com>. 382

**Key words:** president, executive, political responsibility, constitution, America, Iran, France

### Comparative Study of Political Responsibility of Iran, France and America Presidents

#### Section 1: Political Responsibility of Iran President

For the authorities delegated to the president, he also has responsibilities which he must be accountable to another authority, if necessary. Surely, the president has responsibilities. Since it is so-called that power brings about corruption and perhaps people's elect president violates his legal assignments, the president is held accountable for nation, parliament and leader in Iran (Principle 122 of Islamic Republic of Iran Constitution). Before constitution revision in 1989, the president was just responsible for nation. Before revision, principle 122 of constitution indicated that the president is responsible for nation regarding his authorities and assignments. Existence of prime minister and his extensive responsibilities in executive, the president was not responsible for parliament and leader (Yazdi, Mohammad, 1996) which, after revision in 1989, all authorities of the prime minister were delegated to the president. So, based on revised principle 122 of constitution, the president is responsible for people, parliament and leader. Concerning the responsibility of the president for nation, we must say that it is a moral one (Hashemi, Mohammad, 1996). Beside the fact that there is no controlling factor in this regard, no executive guarantee is anticipated for it. Like the president takes nation as his witness in oath ceremony and undertakes heavy commitments for nation, about his political responsibility for parliament, it must be said that Islamic Consultative Assembly is authorized to censure the president and rule against his political qualification based

on two third of total members' votes (Principle 89 of Islamic Republic of Iran Constitution). But there is also another aspect to the responsibility of the president and that is his responsibility for parliament regarding actions of the board of ministers (Hasani, Hasan, 1990). Because ministers under his headship form a board called board of ministers which itself has a character separate from each of the ministers and decisions of the president or board of ministers also play an important role in managing the country, as a result, it is normal that headship of the board of ministers (i.e. the president) is responsible for parliament regarding acts and decisions of the board.

Concerning the responsibility of the president for leader, it can be argued that Iran president deposition suggestion is submitted to leader position by parliament or from his condemnation by Supreme Court of the land and then the position takes action to deposition him based on prudence of the country (Principle 134 of Islamic Republic of Iran Constitution).

Political responsibility of the president as the head of executive; since president is responsible for execution of the rules, in case of execution or mis-execution and or violation of rules by the position, political and legal values of society are ignored and he must be accountable for his deeds in this regard.

Also, since the president is financial treasurer of the land through his colleagues and holds government's budget and great part of public belongings and properties, to take extreme caution and avoid probable abuse, constitution assigns that the properties of the position and his family (as with other governmental supreme positions) must be inquested by headship of judicature before and after

tenure so as not to be increased by breaching any rights (Principle 142 of Islamic Republic of Iran Constitution).

### **Section 2: Political Responsibility of France President**

France president is only responsible for treason and it is only then that he is responsible or parliaments, namely, two parliaments can accuse him by formulating indictment through the same votes in overt voting and with absolute majority of the members. Since the deed is done by parliament, it is titled as political responsibility. Upon formulation of indictment by the parliament, Supreme Court of justice will try him (Article 68 of France constitution). As seen, in France, unaccountability of the president for his own deeds is accepted as a principle and his responsibility is an exception on the principle and only realized at the time of treason. However, treason has a variety of instances determined by parliament. So, inquest of the president's political misfeasance requires many formalities and a special court. The president is not responsible for people or any other positions. The extensive authorities of the president and his narrow responsibilities were due to the role General De Gaul played in formulation of present France constitution. One the other hand, since executive responsibility is in prime minister's charge, the unaccountable president can win his own policies better. It is noteworthy that before 5<sup>th</sup> revolution (1958), the president was unaccountable yet had not so much power. The only action he could take was to elect and assign prime minister. Other decisions could be implemented when authorized and signed by the minister in charge or the prime minister (Hasani, Hasan, 1990).

In France, for the absolute majority of members to always set the assignments of the board of ministries, it is declared that vote of majority of total members (not the audience) is required for the government's fall. Both parliament and government can request trust vote. Parliament's suggestion can be posed when at least one tenth of the members sign it. Negotiations get started 48h after proposal and if absolute majority of total members does not vote for distrust when voting, the government still stays and the censure can be repeated at the same assembly (Madani, Jalalodin, 1995). Indeed, since the parliament is formed based on parties in France, it is enough for the government's fall that the opponent party's leader can have a majority of negative-voice members in the censure. And, whenever the government has the majority in the parliament, he might initiate reception of trust vote and thus prove that he has the support of parliament's majority. Censure and request for trust vote are two actions of the parliament and government to show the power of each in France (Madani, Jalalodin, 1995).

### **Section 3: Political Responsibility of America President**

Due to the system of forces separation in America, each of the three forces are detached and has some extent of independence. Congress just does legislation affairs; executive does administrative affairs and courts do judgment and suit. In headship regime of America, since the president is a result of nation's votes and not assigned by parliament, he has great reputation and does not need

to gain trust vote of the parliament and he is also independent in appointing his ministers and does not need the congress agreement. Congress cannot take action to censure ministers and consequently has no political responsibility for congress or any other positions. And, he does not have to account for his function and fulfills his assignments independently.

### **Comparative Study of Juridical Responsibility of Iran, France and America Presidents**

#### **Section 1: Juridical Responsibility of Iran President**

If the president – as supreme position of the land – commits deeds damaging rights and freedoms of people in fulfilling his political and executive assignments, he will be prosecuted not only politically but also criminally. Although constitution of Islamic Republic of Iran has implied political crime, not certain definition for the term has been presented by legislator regarding the essence and extent of the political crime. Also, concerning the inquest of the president accusation of common crimes is done by informing Islamic Consultative Assembly and in common courts of judicature (Hashemi, Mohammad, 1996).

Whenever the president commits a common crime like bribery and jobbery, he is criminally responsible and has no juridical immunity, but he will be prosecuted just like other common people. The inquest will be done by informing Islamic Consultative Assembly and in common courts of judicature (Principle 142 of IRI constitution). Of the reasons for informing the parliament is that judicature does not protest executive and or the president illusory alibis and inhibits him from fulfilling his assignments. Hence, the legislator has asked for the parliament to be informed of it (Safar, Mohammadjavadi, 1991). In general, where any deeds of the president resulted from his fault causes any damages to the government and/or the third persons, he will be responsible for paying it off. This type of responsibility interpreted as civil responsibility is not anticipated in constitution but based on general principle of public equality for law and also based on principle 107 and paragraph 14 of constitution's principle 3, it is a vested and peremptory affair. In general, regarding Lazara Rule in Islam, losses imposed to individuals due to the other one's deed must be compensated for and there is no difference between the president and other people.

Since Supreme Court can plea the leader for the president's deposition in case of his violation and condemnation (Article 19 of setting the area of Iran president's assignments and power), perhaps at the first glance it seems that direct role of judicature in detecting the president's violation and making final decision in this regard goes against the independence and separation of forces, and also be in conflict with the soul of power and the philosophy of the presidency position superiority in the whole regime. But it must be said that if Supreme Court of the land has any responsibility in this regard, it is only due to the juridical nature of the president's violation issue and based on the authorities delegated by judicature. Because the Supreme Court just plays a role in detecting the violation and has no power in making final decision. And, no doubt, this extent of interference will not lead to violation of executive dependence by judicature (Amid Zanjani, Abasali, 1987).

**Section 2: Juridical Responsibility of France President**

In some political regimes, special type of judgment is taken according to the specifications of the culprit known as political judgment. In political judgment, some accusations of officials including the government headship (king), president and prime minister and also ministers are tried with special formalities and exclusive and specific authorities (Qazi, Abolfazl, 1974). Concerning basic law of France, juridical responsibility or on the other hand satutory responsibility of the president has been approved. About satutory responsibility, we must say that it is resulted by committing crime, when there are reasons indicating that the president has committed a deed banned or can be penalized by law, it imposes satutory responsibility which might be in areas such as robbery, jobbery, treason, freedom misfeasance and ... resulting in satutory responsibility (Madani, Jalalodin, 1995).

Basically, since the aforementioned officials have a sort of political immunity, there is a special order regarding the inquest of criminal responsibilities. What is stated in France constitution shows unaccountability of the president concerning the implementation and execution of his assignments except in cases of treason which is stated as follow in Article 68 of France constitution: "the president is not responsible for actions he usually takes in fulfilling his assignments except in case of treason".

So, regarding satutory responsibility, constitution trend is propelled toward unaccountability of the president, especially based on Article 64 of France constitution, the president is recognized as the guard of judicature dependence and even headship of judicial Supreme Council.

As described above, it was due to the principle role General De Gol played in formulating constitution. Even. About satutory responsibility of embarking treason, the inquest rite of this accusation is also complex so that in such cases two parliaments formulate indictment by absolute majority in overt voting against the president and upon the formulation of the indictment regarding the president's treason, it will be the time for inquest in Supreme Court of justice.

In fact, Supreme Court of justice is the only authority for the inquest of the president's crimes. Its members are elected by two parliaments (Article 67 of France constitution) and number of the members from national assembly and senate is the same composed of 24 main members and 12 switching ones. Competence of the court is basically excluded to trialing the president and cabinet member and prime minister which regarding president per se it has the competence regarding the inquest of treason and of misdemeanor and crime for ministers and prime minister.

It has an exclusive competence concerning satutory responsibility of the president and only trials the case of treason, but there is national security office in other cases like crimes against security. Rule of Supreme Court neither can be investigated nor can be appealed; that is, it must be enacted as a peremptory rule.

Except in case of treason, the president's responsibility is not basically justified (Hasani, Hasan, 1990), but regarding the limits and affairs related to treason, it can be

said that heavy treason of the president includes significant negligence in fulfilling his legal assignments and also embraces compromise and conspiracy and hidden relationship with a foreign power or enemy related to war and or during war.

So, the president is only responsible for judicature in this regard. But if we refer to the articles of France constitution and also the president's assignments, we will witness the existence of almost juridical assignments and authorities; for instance, criminals' amnesty based on Article 17 of France constitution in the president's charge or as described before the headship of judicial Supreme Council is in his charge.

So, it can be concluded that in basic law system of France, although it has accepted the principle of the president's political unaccountability (Hasani, Hasan, 1990) and only taken him as criminally responsible for treason, it can be said that satutory responsibility of the president is created through judicial power of parliament so that without declaring indictment by two parliaments, it will not be possible to create satutory responsibility for the president and the inquest of Supreme Court. It is because the possibility for taking unsteady political actions against authorities of the country is not simply feasible; especially, in France, political struggle and party coalitions have highly thrived.

**Section 3: Juridical Responsibility of America President**

In the USA, we can present a dual role regarding judicature; on one hand and above all, at the first glance it seems that Supreme Court of the state appointed by the president does not possess essential tools to enforce on the president.

But it must be noted that the other side of the coin is basically the law on defending constitution and in general judicial supervision on constitution refers to Supreme Court of the state (Bargahi, Mohammadreza, 1997). On the other hand, since the judgment of Supreme Court of the state is lifelong, it seems that in reciprocity and liability between the president and judicature, the power direction tends toward judicature and in particular Supreme Court of the state so that Supreme Court of the state can change circle of the president's responsibilities pro rata time based on maneuvers that it presents in interpretation of constitution.

Although headship method has been accepted in basic law system in the USA and basically the president is exempt of political responsibility, he has satutory responsibility. And, regarding, satutory responsibility of the president, constitution assigns in paragraph 4 of Article 2 that: "the president, vice president and all civil officials of the USA will be dismissed by accusation from House of Representatives and accusation of treason, bribery, or other important crimes and misdemeanors". Unlike exemption of political responsibility, what is addressed regarding the satutory responsibility of America is very extensive.

Indeed, like France basic law system, basic law system of the USA has also taken parliament judicial authorities method, namely, satutory responsibility of the president begins when House of Representatives of the US declares

treason so that in case of getting informed of the crime commitment by the president, House of Representatives will form an investigation commission about it and review it and the commission present a detailed report to the House in which the accusation items are mentioned and if the report is approved by the representatives, the president accused in this way will be trialed in senate (Article 3 of Constitution).

In fact, senate is turned into a covert court and in case of condemnation, the president is deposed so that the president is prosecuted by House of Representatives for treason and also his immoral deeds and senate held under the headship of Supreme Court of the US will trial him. To condemn the president, two third of the senate representatives' votes are required. Senate can only deposed the president from his position and after declaring the order, the president will be arrested by the competent court and condemned and or cleared (Qasemzadeh, 1961).

Basically, the method taken for statutory responsibility of the president of America is based on judicial power delegated to parliament. This inquest method in the US is emanated from basic law system of the UK because in the UK and in the inquest of the president's crimes, first the duty of investigation and collection of reasons and respective accusations is delegated to House of Common in a special rite and issuing the order is delegated to House of Lords.

So, in America, judicature basically plays no role in the inquest of the president's statutory responsibility and indeed it is the congress investigating the case.

### Conclusion

What is tangible regarding the responsibility of the president in three given countries is the implementation of three different methods of inquest: in Iran, it is done by judicature. Supreme Court of the country investigates the president's crimes like other common people and rules. But the only limitation existing in this regard is that Islamic Consultative Assembly must get informed of the inquest and it basically plays no role in discovering, prosecuting and declaring accusations against the president. This inquest method is taken against common crimes. And, basically, there is not special court for trialing the case. As stated in Principle 140 of IRI constitution, "the inquest of the president, vice president, and ministers' accusation of common crimes will be done by informing Islamic Consultative Assembly and in common courts of judicature". No special formalities are anticipated in the inquest, because based on constitution, all of the people are the same for law and all will equally be treated. But sometimes such as controlling financial affairs, the inquest is done by the head of judicature based on Principle 142 of IRR constitution. It seems that it makes a great distinction between Iran and the two other countries (France and America) regarding the president's responsibility; that is, firstly, the principle of the president's responsibility is very general in Iran so as to embrace common crimes, whereas in France and America some limits are implemented in this regard; for example,

president of France is responsible for treason yet free in other cases. In America, the president's responsibility just includes cases of misdemeanor and crime based on paragraph 4 of Article 2.

Secondly, in Iran, no special authority and exclusive inquest rite is considered for the inquest of the president's responsibility. Only, in Principle 140 of IRI constitution, it is mentioned that it must be done by informing the Assembly and it is the only difference between the inquest of the president and common people, while in each of the two countries (France and America) special rite and method are taken for the inquest of the presidency's crimes so that it is done by declaration and detection the accusations by the House of Representatives in America and via formulating the indictment by national assembly and senates in France.

Moreover, there are differences between France and America regarding the inquest of the president's statutory responsibility; namely, in America, parliament judicial power method is taken so that no special court is made for the inquest of the president's crimes but by declaring the accusation by the investigation commission and the approval of House of Representatives of America, the inquest and issuing condemnation order are done by senate, while in France parliament has is not to issue condemnation order but both assemblies take action to declare indictment against the president and the rule is issued by Supreme Court of justice. In Iran, if the assembly rules for the president's deposition due to his political competence, it is not enough and effective on its own. That is, the assembly just achieves the detection of the matter (incompetence) by its investigations and thereafter the deposition order is issued by the leader and based on his prudence.

### References

1. Constitution of Islamic Republic of Iran
2. France Constitution
3. Constitution
4. Determining area of IRI president's authorities Act
5. Bargahi, Mohammadreza, comparative law, Tehran: Islamic Azad University publications, Vol. 1, 1997.
6. Hasani, Hasan, Supreme Authorities of executive in Iran and France and comparative study of them, Tehran University publications, 1<sup>st</sup> print, Tehran, 1990.
7. Safar, Mohammadjavad, familiarization with IRI constitution, governmental management education center publications, 1<sup>st</sup> print, Tehran, 1991.
8. Qazi, Abolfazl, Basic law and political organs, Tehran University publications, 1<sup>st</sup> print, Tehran, 1994.
9. Ghasemzadeh, Basic law, Ibn Sina publications, 7<sup>th</sup> print, Tehran, 1961.
10. Amid Zanjani, Abasali, Political Fiqh, Airkibir Publications, Vol.1, 1<sup>st</sup> print, Tehran, 1987.
11. Madani, jalalodin, comparative political law, Ganj-e Danesh publications, 1<sup>st</sup> print, 1995.
12. Hashemi, Mohammad, IRI basic law, Qom Higher Education Center publications, Vol. 2, 1<sup>st</sup> print, Qom, 1996.
13. Yazdi, Mohammad, Constitution for all, Amirkabir publications, 1<sup>st</sup> print, Tehran, 1996.

11/4/2012

## Quality of life, its early change and retention in MMT program in Iran: Evidence for policymakers and service providers

Samad Rouhani<sup>1</sup>, Farzan Kheirkhah\*<sup>2</sup>, Iraj Salarieh<sup>3</sup>, Saleh Abedi<sup>4</sup>

<sup>1</sup> Assistant Professor, Department of Public Health; Psychiatry; Behavioral Sciences Research Center, Mazandaran University of Medical Sciences, Sari, Iran & Hospital Management Research Centre, Tehran University of Medical Sciences, Tehran, Iran

<sup>2\*</sup> Corresponding Author, Associate Professor, Department of Psychiatry, Faculty of Medicine, Babol University of Medical Sciences, Babol, Iran

<sup>3</sup> M.D., Chief of Emergency Department, Yahyanejhad Hospital, Babol University of Medical Sciences, Babol, Iran

<sup>4</sup> Clinical Psychologists, MMT Consultant, Babol University of Medical Sciences, Babol, Iran

[Drfarzankh@yahoo.com](mailto:Drfarzankh@yahoo.com)

**Abstract:** Substance abuse is now a major public health problem in Iran. Opioid substances jeopardize different aspect of health and wellbeing of addicted people resulting in low level of quality of their life. Methadone Maintenance Treatment (MMT) is a universally recognized effectiveness method of pharmacological treatment for drug dependents. Maintenance in treatment is the main concern for MMT programs. In this study we investigated the role of quality of life (QOL) and its early change as predictors of retention in MMT program. In a longitudinal study we followed-up subjects (N= 203) for six months from the start of their treatment in a MMT clinic in the city of Babol-Iran in late 2009 till early 2010. We have measured the quality of life of patients before starting the treatment as baseline data, and two subsequent measurements at the end of first and six months as outcome data by EQ-5D questionnaire. Using SPSS software package version 17.0 t test, correlation coefficient, and chi-squared tests were run to predict retention in treatment at least for six months. Patients entered in this study had relatively different socio-demographic background. People with lower level of quality of life had better improvement during the first month of treatment and retained in the MMT program longer. Among all variables of study, just baseline score of quality of life and its early change were statistically significantly related to retention in treatment program at least for six months. Substance abusers who more suffer from opioid substances benefit more from MMT program, therefore, they are keener to quit their addiction and stay longer in MMT program. Hence, quality of life of addicted patients before entering the treatment program is an important predictor of both early progress in their quality of life and longer retention in MMT program. The policy change based on the evidence of this research is recommended.

[Rouhani S, Kheirkhah F, Salarieh I, Abedi S. **Quality of life, its early change and retention in MMT program in Iran: Evidence for policymakers and service providers.** *Life Sci J* 2012;9(3):2633-2638] (ISSN:1097-8135). <http://www.lifesciencesite.com>. 383

**Keywords:** Keywords: Quality of life; MMT; retention; policymaker

### 1. Introduction

Iran's suffering from substance abuse and drug addiction has long history (Mokri, 2002; Calabrese 2007; Goodarzi et al., 2011; Dolan et al., 2012). Because of different cultural, social, legal and political issues, determining the exact figure of addicted people in Iran is not easy (Ardebili, 2006; Mokri 2002; Goodarzi et al., 2011), however, different reports estimated the number of substance abusers between 700,000-4,000,000 (Mokri, 2002). With reference to the World Drug Report 2008 (UNODC, 2008), authors mentioned Iran with a highest rate of opiate drug abusers in the world (Shekarchizadeh et al., 2012). There is also a concern that the problem is worsening as the number of addicted patients is increasing together with a decrease in addiction age (Mokri, 2002). Iran's high burden of substance abuse could be namely because

of three reasons: First, Iran is a neighbor of Afghanistan, the world's major producer and exporter of opioid substances. Second, Iran is the transit route for drug smuggling produced in Afghanistan and destined towards European countries resulting to easier accessibility to these substances in the countrywide. Third, having high level of unemployment beside lack of appropriate recreational facilities for youngsters, create a situation with more vulnerability for substances misuse (Calabrese, 2007; Goodarzi et al., 2011; Dolan et al., 2012). Realizing the damage that these substances make on different aspect of health and daily life, this problem is now felt as a major public health issue for Iranian nation. Counter-drug policy has long history in Iran, which most of them focused on supply side approach and non-pharmacological methods such as detention, financial and even capital punishment. In recent

years, besides continuing non-medicine approach, the government of Iran has chosen to employ pharmacological method as a demand side approach for harm reduction and management of demand for opioid substances. In 2002, Ministry of Health & Medical Education in Iran has established the first Methadone Maintenance Treatment (MMT) clinic in this country to treat substance abusers. Also the parliament of Iran gave all doctors the permission to prescribe methadone for addicted patients under the specific guideline introduced by ministry of health. Soon after the number of MMT clinics scaled up at the country level both in public and private sectors (Calabrese, 2007).

MMT programme is universally recognised as an effective pharmacological method in dealing with addicted patients (Shekarchizadeh, 2012, Rouhani et al., 2012). To attain a better outcome in MMT program, it is critical that patients stay longer in the treatment (Darke et al., 2005). Nonetheless, studies in developed and developing countries demonstrated that retention rate in MMT program varies between 30 to 60% in the first year of the treatment (Bell et al., 2006; Rumah Sakit Ketergantungan Obat [RSKO], 2008).

In terms of different factors affecting the length of stay in treatment, authors pointed out variety of variables that could be categorized as treatment characteristics, patient characteristics, and societal characteristics (Shekarchizadeh, 2012) each encompassing different criteria. Some authors reported that pre-treatment characteristics have little predictive value for staying in treatment program of substance abusers, therefore, suggested early treatment response as predictor of treatment retention (McLellan et al., 1997; Morral et al., 1999).

There is little controversy that drug addiction damages all aspects of health as well as daily life. Accordingly treatment interventions must focus more on the outcomes that comprises different aspects of health such as physical, mental and social well-being known as Health Related Quality Of Life "HRQOL" (Miller and Miller, 2009; Karow et al., 2010).

Therefore in the field of drug addiction improvement in quality of life, as an indication of patient functioning and well-being rather than social and family preferred changes, is more appropriate measure of treatment outcome (Habratt et al., 2002; Padaiga et al. 2007). Hence, HRQOL measurement is increasingly performed in the field of drug addiction studies (Torrens et al., 1999; Ventegodt & Merrick, 2003).

Many study findings demonstrated the positive impact of drug addiction treatment interventions on HRQOL (Ventegodt and Merrick,

2003; Maremmani et al., 2007; Ponizovsky and Grinshpoon, 2007), however, investigations indicating the relation between HRQOL improvement and retention in treatment interventions for drug abusers is rare. One longitudinal study in Taiwan has reported the association between better QOL and longer retention in MMT program (Wang et al., 2012).

Given the fact that length of stay in treatment is an important factor for the outcomes of MMT programs, further research needs to be done to predict the patient retention. In this study we have used addicted patients' quality of life and its early change as predictors of retention in MMT program in Iran.

## 2. Material and Methods

We studied all addicted patients who have enrolled in a MMT clinic in the city of Babol in Mazandaran province from November 2009 to March 2010. It was a longitudinal study that followed-up subjects (N= 203) for six months from the start of their treatment. Patient, treatment and social characteristics of all subjects were taken from patient file that is routinely collected in MMT clinics in Iran. Disease-specific instruments commonly used in addiction research for the measurement of HRQOL are: the Maudsley Addiction Profile "MAP", (Marsden et al., 1998), the Symptom Checklist "SCL-90", (Arrindell and Ettema, 1986) and the European Addiction Severity Index "EuropASI", (Kokkevi and Hartgers, 1995). One of the most frequently applied quality of life measurement tool is the EuroQol questionnaire "EQ-5D", (EuroQol Group, 1990). The EQ-5D is a brief, simple and easy-to-use self-completion questionnaire that its validity in addicted populations has been confirmed (Zanden et al., 2006). We have used for the measurement of quality of life. The quality of life of patients were measured before starting the treatment as baseline data, and two subsequent measurements at the end of first and six months to assess early and continued change in quality of life as an outcome of the treatment. Using SPSS software package version 17.0 t test, correlation coefficient, and chi-squared tests were run to predict retention in treatment at least for six months.

## 3. Results

During the period of study, there were 203 patients who entered into the MMT program in the designated clinic in the city of Babol. Using predetermined instruments, we have collected data from participants at their entrance in the program and followed them up for six months from the start of their treatment. They were different in terms of patient, treatment and social characteristics. Table 1 shows different background of attendees.



Table 1: Patient, treatment, and social characteristics of addicted patients joining MMT program in Omid Clinic in Babol-Iran 2009-10

Patient, treatment and social characteristics	Number	Rate (%)	
Age at admission	<17-39 years	129	63.5
	≥40 years	74	36.5
Gender	Male	201	99.0
	Female	2	1.0
Marriage	Couple	174	85.7
	Single	29	14.3
Children	Having child	146	71.9
	No children	57	28.1
Location of residency	Urban	105	51.7
	Rural	94	48.3
Education	<5 years	54	26.6
	6-12 years	129	63.5
	Higher education	20	9.9
Housing	Homeless	41	20.2
	Owner	161	79.3
Job	Having a job	12	5.9
	Jobless	191	94.1
Years of substance abuse	< 1 year	92	45.3
	≥ 1 year	110	54.2
Method of drug use	Smoking	110	54.2
	Oral	37	18.2

As table above indicates participants were from relatively different socio-demographic background.

The follow-up of all 203 patients for six months from their entrance into the program has shown that 90.1% (183 cases) and 46.3 % (94) have stayed in the program at least for one and six months respectively. Retention in the MMT program had no statistically significant correlation with patient, treatment and social characteristics presented in table 1. The quality of life of patients has been measured in 3 occasions including before the start of treatment, one and six months after treatment. Table 2 indicates the score of patients' quality of life and its during treatment.

As table above shows the quality of life of patients who stayed in treatment program was steadily increased. We have used the score of quality of life of patients before the start of treatment and its change after one month of treatment as predictor of staying in the programme at least for six months. The result of this analysis is shown in table 3.

As table above shows patients who retained in the program at least for six months, had statistically significantly lower level of quality of life from the beginning. But in terms of early change in the quality of life as an outcome measure of treatment, patients who retained in the program for at least six months, had statistically significantly bigger

improvement in the quality of life during the first month of the treatment. In the other words patients who had lower level of quality of life had more improvement in the early stage of treatment and stayed longer in MMT program.

Table 2: Quality of life before treatment and its change during MMT program in Omid Clinic in Babol-Iran 2009-10

QoL score of all patients	Before treatment	1 Retained at least month in treatment	6 Retained at least month in treatment
Number of participants	203	183	94
Score Min	-0.59	-0.48	0.00
Score Max	1.00	1.00	1.00
Score mean(S.D)	0.45 (0.43)	0.71 (0.30)	0.85 (0.24)
Score change at month 1 Mean(S.D)	NA	0.28 (0.41)	0.30 (0.47)
Score change from month 1 to 6 Mean(S.D)	NA	NA	0.17 (0.31)
Score change from month 0 to 6 Mean(S.D)	NA	NA	0.47 (0.43)

Table 3: Quality of life before treatment, its early change and retention in MMT program in Omid Clinic in Babol-Iran 2009-10

Six month retention in MMT	QoL before treatment		Change in QoL one month after treatment	
	.00	1.00	.00	1.00
Number	109	94	109	94
Mean	.5103	.3824	.1080	.2993
Std. Deviation	.38788	.46581	.47551	.46501
Std. Error Mean	.03715	.04804	.04555	.04796
P value	0.034		0.004	

#### 4. Discussions

Opioid substances jeopardize the quality of life of addicted patients through damaging different component of their health including biological, mental and social aspects of their well-being. From this point of view it is appropriate to measure the impact of opioid substances as well as the outcomes of treatment interventions of these patients with using of instruments that create a global score encompassing different aspects of health of an individual such as EQ-5D. Quality of life improvement is one of important criteria of program effectiveness. This measure should be applied to drug

dependent programs to assess the impact of treatment on patient functioning and well-being rather than social and family preferred changes (Habrati et al., 2002; Padaiga et al., 2007). Drug dependent patients entered in this study came from different background. Without any statistically significant difference, they achieved better quality of life as they underwent to the MMT program. Then this finding shows that like many other studies, MMT programme as a newly approached pharmacological treatment in Iran (Mokri, 2002), is an effective program for drug dependents with different characteristics (Ball et al., 1988; Simpson & Joe, 1997 ; Padaiga et al., 2007; Rouhani et al., 2012). Again like many other studies (Bell et al., 2006; Joe, Simpson, & Broome, 1999; Rumah Sakit Ketergantungan Obat [RSKO], 2008), we have found that retention in MMT program is below, so that more than half of (46.3%) of patients had dropped out before six months from the start of their treatment. Given the positive impact of MMT program, the same as other studies, early drop out and low retention rate should be the area of concern for MMT programme in Iran too. Experts when speak about the effectiveness of this program their most frequently mentioned concern is early withdrawal of patients from the treatment program. In this regards there are loads of studies in this field that has been focused to address the issue of early termination of patients from MMT program (Simpson & Joe, 2004; Darke et al., 2005). In this study we have investigated retention in MMT program at least for six months period and its association with different patient, treatment and social characteristics. As table 1 shows these characteristics include variables such as age at admission, gender, coupling, having child, location of residency, education, housing, job, years of substance abuse, method of drug use, type of drug, daily expenditure on drug, methadone dose plus quality of life of patients before and during follow up period at months one and six. Quality of life of patients before treatment as a patient characteristics and change of quality of life after joining the treatment program as a treatment characteristics or outcome measure of treatment program were only two variables that have changed statistically significantly with retention for at least six months in the MMT program. In our study, these two variables of quality of life have differently predicted at least six months retention in MMT program. As table 3 indicates, baseline score of quality of life for those who have left the programme before one month, was higher than for those who had lower score of quality of life at their entrance in the program. But change in the quality of life during the first month of treatment was observed more among those who had lower quality of life at their entrance. Lower level of quality of life should

be taken as a side effect of substance abuse on different biological, mental and social wellbeing of addicted patients. Therefore people who suffer more from their addiction are more possible to gain from treatment and therefore are keener to quit substance abuse, hence they will retain in the treatment program longer. Regarding to treatment outcome and retention in program, authors found that patient satisfaction, as a measure of program outcome, is an important predictor of retention in MMT program (Villafranca et al., 2006; in 26; 26; Kelly et al., 2011; Villafranca et al., 2006). It also needs to be explained that low level of quality of life at the entrance is most probably related to the substance misuse rather than any other hypothetical issues such as family, social, psychological, financial problems. The evidence that supports this idea is the other finding of this research that indicates those who had lower quality of life had more improvement on this indicator during the first month of treatment. Therefore their lower quality of life is nothing except their suffering from substance abuse. This could be explained that people who suffer more from side effects of substance abuse are more willing to quit their drug abuse as they reached to the entire suffering from their addiction than the enjoyment of opioid consumption. However, those who have not yet experienced such situation still are not quite serious to give up the addiction. This could be translated to the concept that they still more enjoy from opioid substances than suffering from its side effects. If we accept this phenomenon, we need to highlight a lack of awareness about the side effects of opioid substances among addicted population that prevent the quitting of substance abuse until they fall into a serious problems. This matter is supported by other authors as they highlighted that problem recognition is key to help seeking and initiating behaviour change (Evans Li, & Hser, 2008; Lieberman & Massey, 2008).

This situation indicates that if we leave addicted people with themselves just those addicted population who have reached to the end of the line might decide to give up their behaviour and therefore approach to alternatives for treatment. But for those who have not reached to this position neither will enter to the treatment program nor will stay to such treatment programs adequately. This highlights that some intervention needs to be implemented to change MMT programme from a passive approach to an active one and employ different channels to encourage more addicted people into pharmacological treatment of addiction and also support them during treatment program for staying in a more appropriate period. The finding of this research that shows a significant association between quality of life and retention in MMT program is

supported by the findings of other authors (Wang et al., 2012) in Taiwan who concluded an association between better QOL and retention in MMT program.

#### 4. Conclusion

Opioid substances jeopardise the quality of life of its abusers. Substance abusers are not aware of the real impact of these materials on their wellbeing. When they reached to the stage that they suffer seriously from the side effects of opioid substances, they might seek to quit their addiction. Before this stage neither entrance and retention into pharmacological treatment, nor quitting it, is taken seriously by the substance abusers. In this stage with the lack of awareness from the side effects of these materials, they more enjoy from opioid substances than suffering from it. Then they do not ready to trade-off substance abuse with pharmacological treatment i.e. methadone. When they experienced the real side effects of addiction and have lost the quality of their life, it is the time that they might seek to find that methadone can help them and they stick to the program because they both experienced the real impact of substance abuse and the positive impact of pharmacological treatment on the quality of their life. Therefore addiction is a matter of quality of life because among the wide range of variables both those who stayed with MMT programme or decided to leave it were mostly different in their quality of life. The score of quality of life at baseline that is an indication of people suffering from substance abuse is a patient characteristics variable that can predict both early improvement in quality of life of patients undergoing in MMT program and therefore longer retention in the treatment. Therefore people with better score in quality of life in the beginning of treatment may not achieve great improvement on their quality of life, therefore are more vulnerable to leave the program. This knowledge can contribute to help program directors to employ alternative supports such as psychological advice more focused to these patients to encourage them to retain in the treatment for a reasonable time. Also based on the findings of this research retention in MMT programme is more achieved by those patients who suffering from their addiction seriously. Therefore for the society of addicted people an active approach of MMT program is recommended to encourage substance abusers for joining and retaining in the treatment program. We recommend policymakers and service providers to translate the finding of this research into practice, and change MMT clinics from the status quo of passive engagement into an active interventionist.

#### Acknowledgements:

Authors tank Mazandaran University of medical sciences and its affiliated psychiatry and behavioural science research centre, and Babol

University of medical sciences that jointly approved and supported this study. Also we appreciate the collaboration of staff in Omid MMT clinic in Babol and all patients who had participated in this study.

#### Corresponding Author:

Dr. Farzan Kheirkhah

Department of Psychiatry, Faculty of Medicine, Babol University of Medical Sciences, Babol, Iran

E-mail: [Drfarzankh@yahoo.com](mailto:Drfarzankh@yahoo.com)

#### References

1. Ardebili, E. M., Salehi, S., Gharai, B., Daneshamuz, B., Nassr, M., Ghalebani, M. F. (2006). A household study on the prevalence of substance misuse in Tehran: The need for other methods to estimate the prevalence. *Iranian Journal of Psychiatry*. 1: 158-161.
2. Arrindell, W.A., Ettema, J.H.M. (1986). *SCL-90: Handleiding bij een Multidimensionele Psychopathologie Indicator*. Swets & Zeitlinger, Lisse (Manual for a multidimensional psychopathology indicator).
3. Ball, J.C., Lange, W.R., Myers, C.P., Friedman, S.R. (1988). Reducing the risk of AIDS through methadone maintenance treatment. *Journal of Health Social Behavior*. 29: 214-226.
4. Bell, J., Burrell, T., Indig, D., Gilmour, S. (2006). Cycling in and out of treatment: Participation in methadone treatment in NSW, 1990-2002. *Drug and Alcohol Dependence*. 81: 55-61.
5. Calabrese, J. (2007). *Iran's war on drugs: Holding the line?* The Middle East Institute Policy Brief. No.3. December. Washington.
6. Darke, S., Ross, J., Teesson, M., Ali, R., Cooke, R., Ritter, A., Lynskey, M. (2005). Factors associated with 12 months continuous heroin abstinence: Findings from the Australian Treatment Outcome Study (ATOS). *Journal of Substance Abuse Treatment*. 28: 255-263.
7. Dolan, D. Salimi, S. Nassirimanesh, B. Mohsenifar, S. Allsop, D. Azarakhsh, M. (2012). Six-month follow-up of Iranian women in methadone treatment: drug use, social functioning, crime, and HIV and HCV seroincidence. *Substance Abuse and Rehabilitation*. 3(Suppl 1): 37-43.
8. Goodarzi, F., Karrari, P., Eizadi-Mood, N., Mehrpour, O., Misagh, R., Setude, S., Amrollahi, M. (2011). Epidemiology of drug abuse (Chronic Intoxication) and its related factors in a MMT clinic in Shiraz, southern Iran. *Iranian Journal of Toxicology*. 4(4): 377-380.
9. EuroQol Group. (1990). EuroQol—a new facility for the measurement of health-related quality of life. *Health Policy*. 16: 199-208.
10. Evans, E., Li, L., Hser, Y. (2008). Treatment entry barriers among California's Proposition 36 offenders. *Journal of Substance Abuse Treatment*, 35: 410-418.
11. Habrat, B., Chmielewska, K., Baran-Furga, H., Keszycka, B., Taracha, E. (2002). Subjective Quality of Life in opiate-dependent patients before admission

- after six months and one-year participation in methadone program. *Przegl. Lek.* 59(4-5): 351-4.
12. Joe, G. W., Simpson, D. D., Broome, K. M. (1999). Retention and patient engagement models for different treatment modalities in DATOS. *Drug and Alcohol Dependence.* 57: 113–125.
  13. Karow, A., Reimer, J., Schafer, I., Krausz, M., Haasen, C., Verthein, U. (2010). Quality of life under maintenance treatment with heroin versus methadone in patients with opioid dependence. *Drug and Alcohol Dependence.* 112: 209–215.
  14. Kelly, S.M., O'Grady, K.E., Mitchell, S.G., Brown, B.S., Schwartz, R.P. (2011). Predictors of methadone treatment retention from a multi-site study: a survival analysis. *Drug and Alcohol Dependence.* 117(2-3):170–175
  15. Kokkevi, A., Hartgers, C. (1995). EuropASI: European adaptation of a multidimensional assessment instrument for drug and alcohol dependence. *European Addiction Research.*1: 208–210.
  16. Lieberman, D., & Massey, S. (2008). Pathways to change: The effect of a Web application on treatment interest. *American Journal on Addictions.* 17: 265–270.
  17. Maremmani, I., Pani, P.P., Pacini, M., Perugi, G. (2007). Substance use and quality of life over 12 months among buprenorphine maintenance-treated and methadone maintenance-treated heroin-addicted patients. *Journal of Substance Abuse Treatment.* 33: 91–98.
  18. Marsden, J., Gossop, M., Stewart, D., Best, D., Farrell, M., Lehmann, P., Edwards, C., Strang, J. (1998). The Maudsley Addiction Profile (MAP): A brief instrument for assessing treatment outcome. *Addiction.* 93: 1857–1867.
  19. McLellan, A.T., Alterman, A.I., Metzger, D.S., Grissom, G.R., Woody, G.E., Luborsky, L., O'Brien, C.P. (1997). Similarity of outcome predictors across opiate cocaine and alcohol treatments: role of treatment services. *Journal of Consulting and Clinical Psychology.* 62: 1141–1158.
  20. Miller, P.G., Miller, W.R. (2009). What should we be aiming for in the treatment of addiction? *Addiction.* 104: 685–686.
  21. Mokri, A. (2002). Brief overview of the status of drug abuse in Iran. *Archives of Iranian Medicine.* 5 (3): 184–190.
  22. Morral, A. R., Belding, M. A., Iguchi M. Y. (1999). Identifying methadone maintenance clients at risk for poor treatment response: pretreatment and early progress indicators. *Drug and Alcohol Dependence.* 55: 25–33.
  23. Padaiga, Z. Subata, E. Vanagas, G. (2007). Outpatient methadone maintenance treatment program quality of life and health of opioid-dependent persons in Lithuania. *Medicina (Kaunas).* 43(3): 235-241.
  24. Ponizovsky, A.M., Grinshpoon, A. (2007). Quality of life among heroin users on buprenorphine versus methadone maintenance. *American Journal of Drug and Alcohol Abuse.* 33: 631–642.
  25. Rouhani, S., Salarieh, I., Abedi, S., Kheirkhah, F. (2012). Impact of Methadone Maintenance Treatment on the quality of life of opioid dependents in city of Babol. *Journal of Mazandaran University of Medical Sciences.* 22 (87): 47-55.
  26. Rumah Sakit Ketergantungan Obat (RSKO). (2008). *Laporan Kegiatan Tahunan (Annual Report) 2007.* Jakarta: RSKO.
  27. Sarasvita, R., Tonkin, a., Utomo, B., Ali, R. (2012). Predictive factors for treatment retention in methadone programs in Indonesia. *Journal of Substance Abuse Treatment.* 42: 239–246.
  28. Shekarchizadeh, H., Ekhtiari, H., Khami, R. M., Virtanen, I. J. (2012). Patterns of pre-treatment drug abuse, drug treatment history and characteristics of addicts in methadone maintenance treatment in Iran. *Harm Reduction Journal.* 9: 18. Published online 2012 June 7. doi: 10.1186/1477-7517-9-18
  29. Simpson, D. D., Joe, G. W. (1997). Strategies for improving methadone treatment process and outcomes. *Journal of Drug Issues.* 27: 239–261.
  30. Simpson, D. D., Joe, G. W. (2004). A longitudinal evaluation of treatment engagement and recovery stages. *Journal of substance abuse treatment.* 27: 89–97.
  31. Torrens, M., Domingo-Salvany, A., Alonso, J., Castillo, C., San, L. (1999). Methadone and quality of life. *Lancet.* 353. 1101.
  32. UNODC. World Drug Report 2008 (United Nations Publication, Sales No. E.08.XI.1). 2008.
  33. Ventegodt, S., Merrick, J. (2003). Psychoactive drugs and quality of life. *Scientific World Journal.* 3: 694–706.
  34. Villafranca, S.W., McKellar, J.D., Trafton, J.A., Humphreys, K. (2006). Predictors of retention in methadone programs: a signal detection analysis. *Drug and Alcohol Dependence.* 83: 218–224.
  35. Wang, P. W., Wu, H.C., Yen, C. N., Yeh, Y. C., Chung, K. S., Chang, H. C., Yen, C. F. (2012). Change in quality of life and its predictors in heroin users receiving methadone maintenance treatment in Taiwan: an 18-month follow-up study. *American Journal of Drug and Alcohol Abuse.* 38(3): 213-9.
  36. Zanden, B. P., Dijkgraaf, M. G. W., Blanken, P., de Borgie, C. A., van Ree, J. M., Brink, W. (2006). Validity of the EQ-5D as a generic health outcome instrument in a heroin-dependent population. *Drug and Alcohol Dependence.* 82: 111–118.

08/18/2012

## A New Technique for Measuring Human Stress Level

Reza Alipour \*, Mohammad Reza Iranpour

Department of Mechatronics, Majlesi Branch, Islamic Azad University, Isfahan, Iran  
[RezaAlipour\\_2007@yahoo.com](mailto:RezaAlipour_2007@yahoo.com)

**Abstract:** Various formerly implemented methods for stress measurement are initially discussed in the current paper. The most common ways of stress measurement are through checking speech, salivary amylase, oxygen saturation in arteries, skin temperature fluctuations, heartbeat rate, blood pressure, pressure at fingertips, and diversity of other methods. Taking into account the higher precision of diagnostic methods based on measurement of heart rate and fingertip pressure, the current research attempts to design a combined technique for improving the measurement and diagnosis accuracy. Variations in heart rate and fingertip pressure are considered here. As such, direct impact of stress is studied on automatic nervous system and parasympathetic nervous system of body, and subsequently, measurement of the two aforementioned fluctuations are taken into account. On this basis, stress fluctuations generally cause changes in heartbeat frequency per minute. Through examining fingertip pressure in the states of presence and absence of stress, it is revealed that rate of fingertip pressure follows a second-order partial differential equation based on Newton's second law. By recording the respective data and combining and analyzing the two abovementioned techniques, a higher precision in stress measurement was achieved compared to the already proposed methods. For this purpose, heart rate and force converters are merged and accuracy of stress measurement improves from 60% to 78%, which in turn offers a novel growth and transformation in the scope of stress level measurement.

[Reza Alipour, Mohammad Reza Iranpour. **A New Technique for Measuring Human Stress Level**. *Life Sci J* 2012; 9(3):2639-2646]. (ISSN: 1097-8135). <http://www.lifesciencesite.com>. 384

**Key Words:** Stress measurement, Heartbeat, Fingertip Pressure

### Introduction

Stress normally originates from a major root that might include psychological tortures and/or momentary changes in mental mode based on different events and abnormalities. Stress is regarded as an essential threat to human health. Today, along with advances in technologies and facilities, the dependences, and consequently, stress for losing them have grown proportionally.

The examples of such disorders are: social abnormalities, cyber offences, and likelihood of personal information disclosure, all of which turn the stress into a threat to individuals. Nonetheless, stress is also an intricate subject to investigate its consequences such as cardiac diseases, diabetes, asthma, and depression. Techniques applied to measure stress level in people are discussed in the present study, which will help determination of stress level for different individuals under variety of conditions in medical equipment science. The findings of the current research can have applications in cases like controlling stress level of car drivers and admonishing to prevent them from driving, avoidance of performing surgery on individual with high stress until stress alleviation, and accordingly, prevention from heart attacks and similar incidents.

Speech examination is among the formerly studied methods for stress level measurement [1]. This method deals with application of Fourier series

on power coefficient at frequencies with linear short wavelengths in two domains of time and frequency. The results indicate that this method features a higher accuracy in diagnosis of stress type as compared to the similar non-linear case. Another technique focuses on amount of saliva amylase and offers a simple computational method for stress measurement [2]. In the third method, a multi-sensor system evaluates oxygen saturation in arteries for different body organs such as ear, mouth, and fingers in order to measure and diagnose the stress [3]. Some software packages have been also implemented to estimate stress level using sensors for measurement of skin temperature [4]. In an alternative approach, different states of human stress are simulated based on fuzzy logic [5]. Expensive sensors are applied for receiving the needed signals in this method [6]. Another technique measures the stress level based on the stressed person's fingertip pressure exerted on a rolling and flexible cylinder [7 and 8]. In this method, dynamic response of the flexible segment of cylinder as a result of the exerted pressure is taken into consideration. In addition, other methods can also serve as novel solutions for expansion of this scientific scope, including detection of: eye flashing frequency, change in skin color [9 and 10] and (Electro-Dermal Activities or EDA), voice tone alteration [11] and tremors in voice induced by stress, change in heart rate (HR), different indices of Heart

Rate Variability (HRV), blood pressure variations, muscular tension, respiration [12 and 15], and also presence of local tremors or exceeded moisture on the skin.

**Preface:**

A new method of combining heart rate changes (and hence number of pulses per minute) and pressure variations at fingertips are analyzed from both the mechatronical and biomechanical aspects in the present paper. All parameters are considered in one collection so as to improve the measurement accuracy. The procedures, of course, must be carried out using covered or mounted sensors to avoid disturbing the person and/or attracting people's attention in public places. For example, EDA technique is among the strongest and most recognized methods in stress diagnosis and measurement. However, the electrodes must be mounted on the palms or fingers in this method, which might lead to restriction of the tested person's freedom and eventually his/her fatigue. Continuous blood pressure measurement is another technique which requires use of pressure recording apparatus. The pressure in this method is normally measured through vein compaction by the air pressure or insertion of a needle into the arteries, which is again a difficult and disturbing procedure. Since heart rate can by itself provide plenty of information about and cover all of these factors, the current method is accordingly designed based on calculations and analyses on heart rate and stress level measurement through its variations.

Automatic Nervous System (ANS) is a part of body's nervous system which helps as a controlling mechanism to maintenance of body at a stabilized condition (homeostasis). ANS consists of two major branches: sympathetic nervous system (SNS) and parasympathetic nervous system (PNS). The SNS branch helps the body to prepare for taking action in response to potential threats. The PNS system is most active when the person feels no challenge or stress, and, maintains the body in a state of relaxation and tranquility. Both major nervous branches directly affect the heart rate but PNS reduces its value. Unfortunately, heart rate fluctuations cannot be easily measured in terms of SNS and PNS values. In fact, it is not easy to determine reduction or increase in which one causes such responses on the heart rate. Of course, pulse rate can be also examined instead of heart rate. Pulse is actually a wave transferred centrifugally from the origin of body arteries or heart to the smaller and peripheral arteries. In other words, heartbeat rate emerges as pulse in the arteries. Changes between each two heart beats shall be examined in order to precisely detect the pulse frequency, which is known

as Heart Rate Variability (HRV) analyses. According to the current study, two important frequency spectra can be assumed. First, frequency interval between 0.04 to 0.15 hertz caused by combination of SNS and PNS and their regular and average functions, and second, the frequency interval between 0.15 to 0.4 hertz created by PNS activity alone [16].

**Assessment and Estimation**

SNS and PNS create a one-dimensional chain which easily begins varying due to the slightest change in stress so that a mutual correlation is established i.e. increase in activity of one branch will be followed by reduced activity in the other one. The following figures simply illustrate this phenomenon [17 and 18].

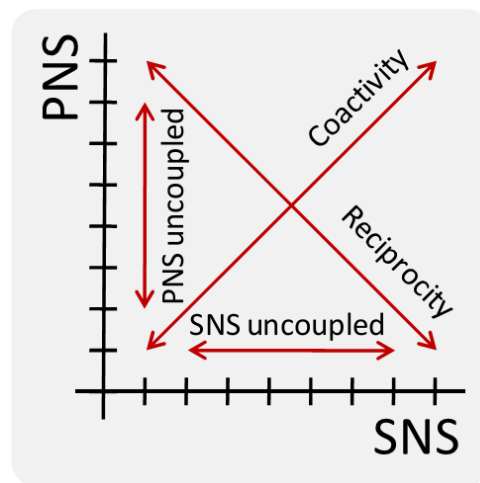


Figure 1. SNS and PNS variations and their interaction

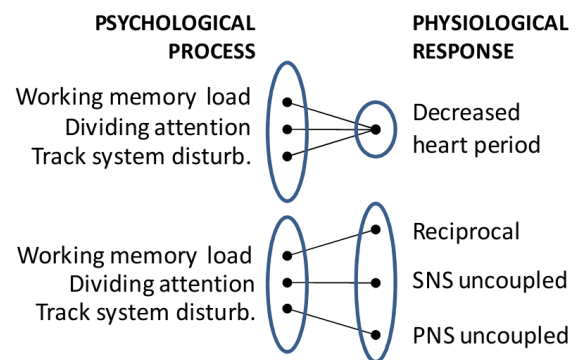


Figure 2: Mutual effect of PNS and SNS and heart rate control [18]

Therefore, SNS and PNS variations, and as a result, stress level in the body can be generally determined if heart rate or pulse is evaluated. Furthermore, fingertip pressure can be also taken into account in order to improve efficiency and lower the error percentage.

**Measurement and Calculation of Fingertip Pressure**

Increased stress in turn causes changes in fingertip pressure exerted on the objects. Such reaction can be analyzed according to the respective

equation and based on Newton’s second law for measuring the force/pressure exerted by the fingertip. The second-order differential equation with partial derivatives is [19]:

(1)

$$\frac{\partial^2 u}{\partial t^2} = \frac{F}{\rho} \frac{u_x(x + dx, y_1) - u_x(x, y_2)}{dx} + \frac{F}{\rho} \frac{u_y(x_1, y + dy) - u_y(x_2, y)}{dy}$$

The following final result is obtained after solving the equation above [19]:

(2)

$$u_{m,n}(x, y, t) = \sin\left(\frac{mx\pi}{a}\right) \sin\left(\frac{ny\pi}{b}\right) \cdot [B_{m,n} \cos(\lambda_{m,n}) + B_{m,n}^* \sin(\lambda_{m,n})]$$

Where; “m” and “n” represent different operational states and “a” and “b” are length and width of fingertip, respectively. B and B\* are the

constants imposed by initial conditions of the problem. λ<sub>m,n</sub> is the Eigen-value obtained via the equation below[19]:

(3)

$$\lambda_{m,n} = k\pi \sqrt{\left(\frac{m}{a}\right)^2 + \left(\frac{n}{b}\right)^2}$$

Where; F denotes the force exerted on the surface in Newton per square meter [19].

model memory in the present research. This memory is able to retain different mental states of the person in stress-free or stressed conditions and help the current equation to yield a more precise prediction and estimation. Primarily, a non-linear system needs to be totally identified and output condition of the system shall be clearly specified. The following equation is applied for this purpose:

**Measurement and Calculation of Heartbeat or Pulse Rate**

Using similar equations, heart or pulse rate can be also directly measured. The HR-related equations might obey a former memory known as the

(4)

$$y(t) = k_0 + \sum_{\tau=0}^{M-1} k_1(\tau)x(t - \tau) + \sum_{\tau_1=0}^{M-1} \sum_{\tau_2=0}^{M-1} k_2(\tau_1, \tau_2)x(t - \tau_1)x(t - \tau_2) + \dots$$

In this equation, y (t) is the same as system output and x (t- τ) is system input with time delay of τ and model memory of M. This equation can be

written in matrix form because it assumes a second-order structure similar to the one for calculation of fingertip pressure:

(5)

$$y(t) = X^T(t)QX(t)$$

$$\text{where } X(t) = \begin{bmatrix} 1 \\ x(t) \\ \vdots \\ x(t - M + 1) \end{bmatrix} \text{ and } Q = \begin{bmatrix} k_0 & \frac{1}{2}k_1^T \\ \frac{1}{2}k_1 & k_2 \end{bmatrix}$$

Due to symmetry of Q matrix, an equation can be defined where  $\lambda_i$ s are Eigen-values of matrix yielding a result as below:

(6)

$$y(t) = X(t)^T Q X(t) = X(t)^T R^T \Lambda R X(t) = U(t)^T \Lambda U(t)$$

$$= \sum_{i=0}^{M-1} \lambda_i u_i^2(t)$$

And "u" value is evaluated through the following convolution:

(7)

$$u_i^2(t) = \{v_i * X(t) + \mu_{i,0}\}^2$$

$$\text{where } v_i = [\mu_{i,1} \quad \mu_{i,2} \quad \dots \quad \mu_{i,M}]$$

Thus, the output value follows the equation below with a close proximity to the real value:

(8)

$$\hat{y}(t) = \sum_{i=0}^S \lambda_i \{v_i * X(t) + \mu_{i,0}\}^2$$

**System Designing and Implementation**

Using a micro-controller together with sensors for detection of heart rate, pressure and also via analysis of their output values in equations of fingertip pressure and heart rate calculations, and, according to the obtained models and equations, a block diagram with a relatively desirable output and high accuracy can be reached for stress level measurement. General scheme of this block diagram is considered as follows taking into account the memory as well as wireless system for avoiding the physical hindrance of the equipments for the tested person [20].

The next figure can be supposed in the sensor detection section of block. This figure shows two sensors which are connected to a micro-controller. One of the sensors measures the force/pressure exerted by the fingertip on the silicon surface, and the other sensor records pulse rate per minute through the fingertip [19 and 20].

The input data can be introduced to micro-controller through keyboard based on which the needed changes can be made for different states or for resetting the system to repeat the test. Instantaneous stress value outputs can be also observed on the

mounted monitor. Of course, different commands might be issued thanks to the program installed on the micro-controller. For example, when a person is driving and the stress value exceeds the pre-defined limit, the command can be issued to stop the car and let the driver get rest, preventing from subsequent risks for the driver [21].

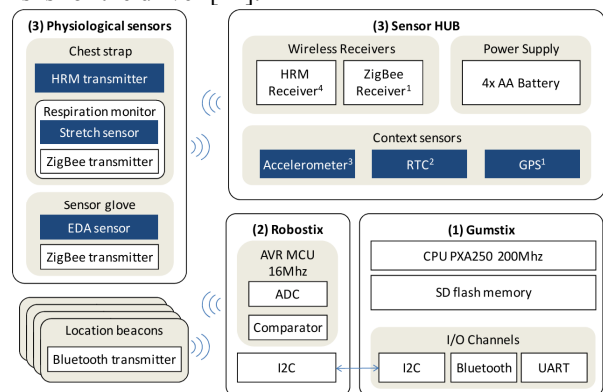


Figure 3- General block diagram of stress measurement system



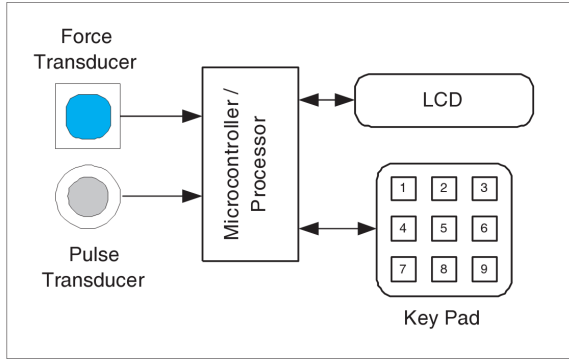


Figure 4- Block diagram of sensors

**Circuit Design and Implementation**

Two main signal-regulating circuits are required for modifying the output signal from converters to micro-controller inputs. The first and second circuits are respectively used for force/pressure and pulse converters. The force/pressure converter is an 1856 model manufactured by Sensor Techniques Company. The output of this converter is a voltage in the range of 0 to 100 mV resulting from an equivalent pressure of 0 to 25 psi [23]. The interface circuit for this converter is illustrated in the next figure. The booster is adjusted in a way that even extremely small voltages are amplified.

This circuit is designed so that detectable voltages are sent to micro-controller as force or pressure values. Hence, it is capable of detecting even the smallest changes in the input and amplifying the signals to the extent that they can be easily read by the micro-controller.

The extent of this amplification is such that it can even detect the smallest values like the stress caused by harsh horn of an automobile. Sensitivity of the output system is of course adjustable in a manner that provides suitable responses for variety of stresses.

Force/pressure versus the generated voltage in this circuit is used for predicting the amount of the exerted force/pressure based on the output voltage in micro-controller. In this diagram, the correlation curve is fitted on the main plot in the form of a straight line with fixed slope.

As illustrated in the following figure, the second circuit regulates the output signal of the sensor which detects fingertip pulse. Pulse converter is a piezoelectric device that transmits its output voltage in the range of 50 to 300 mV through a BNC connector. This signal is boosted in the circuit and sent to a **comparing circuit**. Output of the **comparing circuit** is a series of digital pulses which are transmitted to the micro-controller for counting

the pulse beat frequency per minute. It must be noted that the whole circuit is supplied with a 9Volt battery.

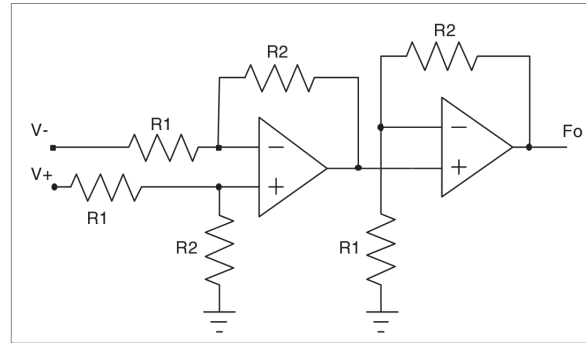


Figure 5- Force/pressure converter

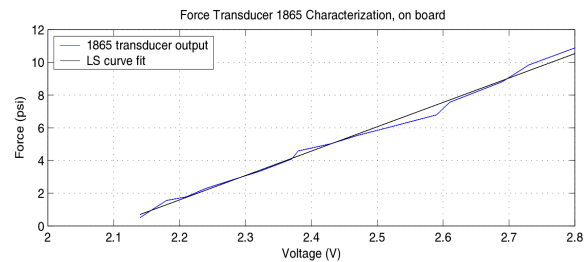


Figure 6- Plot of force/pressure vs. the generated voltage

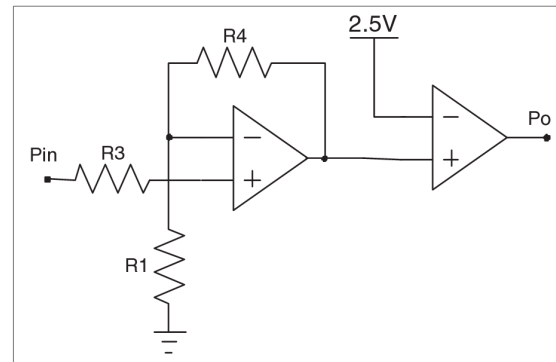


Figure 7-Pulse beat converter

The micro-controller used in the circuit is PCI16F877A manufactured by Microchip Company. This controller contains an 8 KB programmable memory. Code of the defined algorithm is converted into C program in the same way as the needed equation. A 4-Mhz crystal is also used for encryption operation of micro-controller. Two 8-bit digital ports and two single-canal analogue-to-digital converter ports are also incorporated in this sample. Analogue-to-digital converter ports receive output of two signal-regulating circuits for measuring force/pressure and pulse while connected to a keyboard and monitor from another side.

Density and power spectral density (PSD) were compared and also the possibility to assess the

tested microscopic points and density as well as resolution option were utilized in order to better describe the accuracy of the current method in heart rate variability measurement and monitoring versus conventional Electro-Cardio Graphic (ECG) systems. Memory of the mathematical model is selected to be 120--- and the test is run up to 300 seconds, which perfectly demonstrates Heart Rate Monitor (HRM)’s accuracy in comparison with ECG:

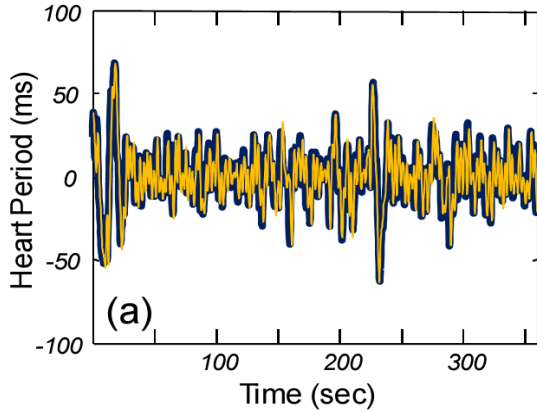


Figure 8 - Heart rate plot and comparison of ECG and HRM

According to the analysis, it was revealed that correlation coefficient of these two signals equal 0.99 suggesting very high measurement accuracy in HRM technique. Heart rate variability (HRV) also had to be studied, and, comparison of ECG and HRM led to the following result.

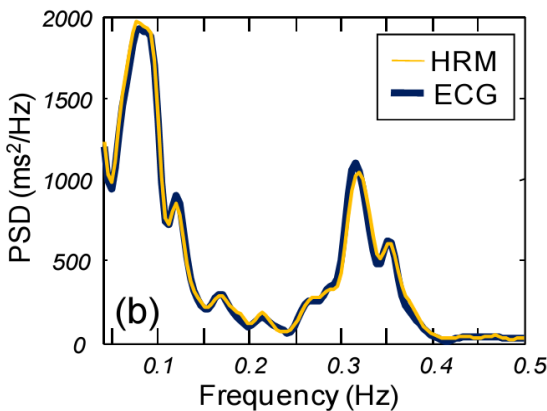


Figure 9 – PSD profile versus frequency variation

**Conclusions**

As observed in force/pressure vs. voltage plot, the correlation between output voltage and the exerted pressure/force is linear and monotonous. Therefore, a first-order equation based on the data received from force/pressure converter can be applied instead of storing a table for values and occupying memory in the micro-controller. Equation of the

respective plot which derives the force from voltage is a curve as below:

$$PSI = 14.8993V - 31.1837$$

A comparison was made to show accuracy of system’s performance and closeness of the fingertip pressure data and heart rate measurement results. Each of the aforementioned equations were separately executed by the micro-controller and ensured closeness of the results obtained from the analytical equations. Thus, combination of these two techniques strongly improves the stress level measurements and will remarkably reduce the system error. This test was carried out on 30 persons whose specifications completely differed in terms of age, gender, and weight.

In the subsequent parts, the distribution graphs illustrate the four operational states based on the function implemented for force/pressure and pulse frequency measurement. The next figure represents one of the operational states.

The former graphs are plotted as a solution to stress diagnosis based on force/pressure measurement. In the first state (the left upper graph), three distinctive classes are well distinguishable. Number (1) represents relaxed or stress-free state; number (2) signifies slightly anxious or having a little stress, and finally, number (3) is indicative of a completely anxious or stressed state (mood).

In the same way, the following figure can be analyzed for the method designed based on pulse frequency per minute (Figure 11).

The results in these two diagrams are somewhat similar to each other. The success chance in the first method was 60% for diagnosing different states of a person out of the three choices, and 78% for general stress diagnosis, which is largely similar to the second method. In the second method, the person will be in the relaxed mood if his pulse frequency is below 80 per minute; the person can be regarded semi-anxious if the pulse frequency lies in 80-90 (per minute) interval, and anxious in the case that pulse frequency exceeds 90 per minute. Obviously, a more rigorous classification is required and the number of samples shall be also enormously increased for improving the accuracy and defining criterion for evaluating and measuring stress level. Nonetheless, combination of these two techniques will contribute to improvement of measurement accuracy besides prevention from erroneous warnings of the system, which in turn will provide a tremendously precise recording of the stress value. Furthermore, sampling speeds of heart rate and fingertip pressure techniques are high leading to quick response and taking the pre-defined action

immediately after induction of the stress to the person.

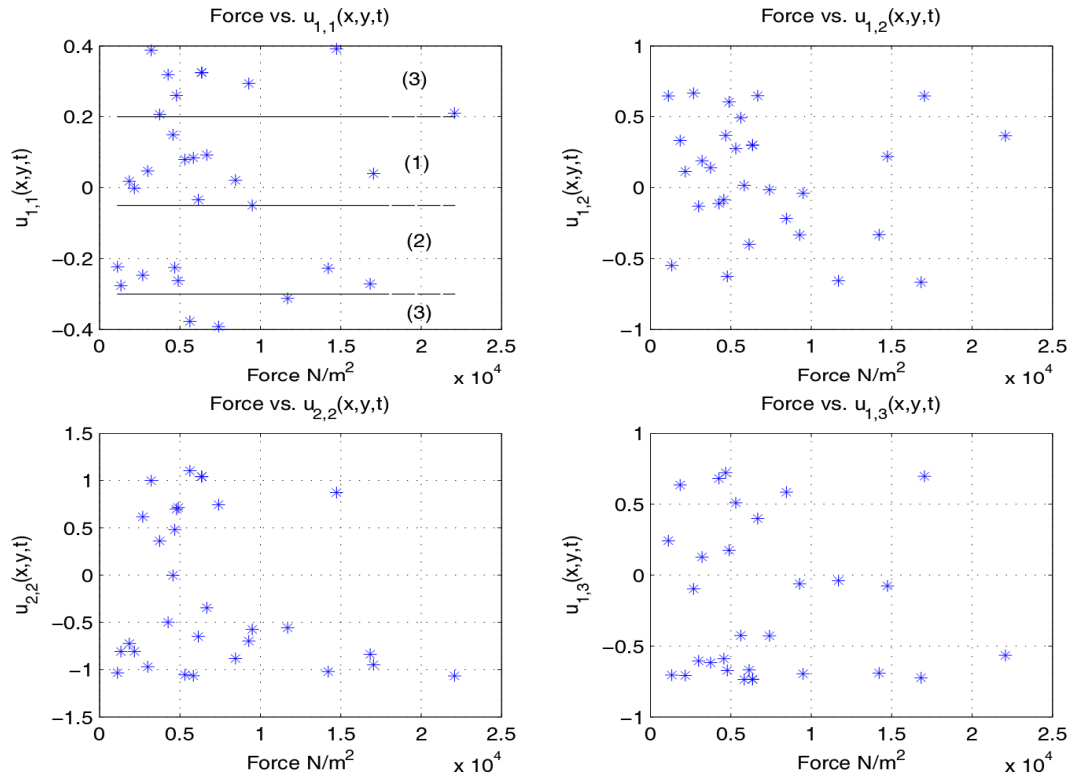


Figure 10 – The samples taken based on changes in fingertip pressure induced by stress

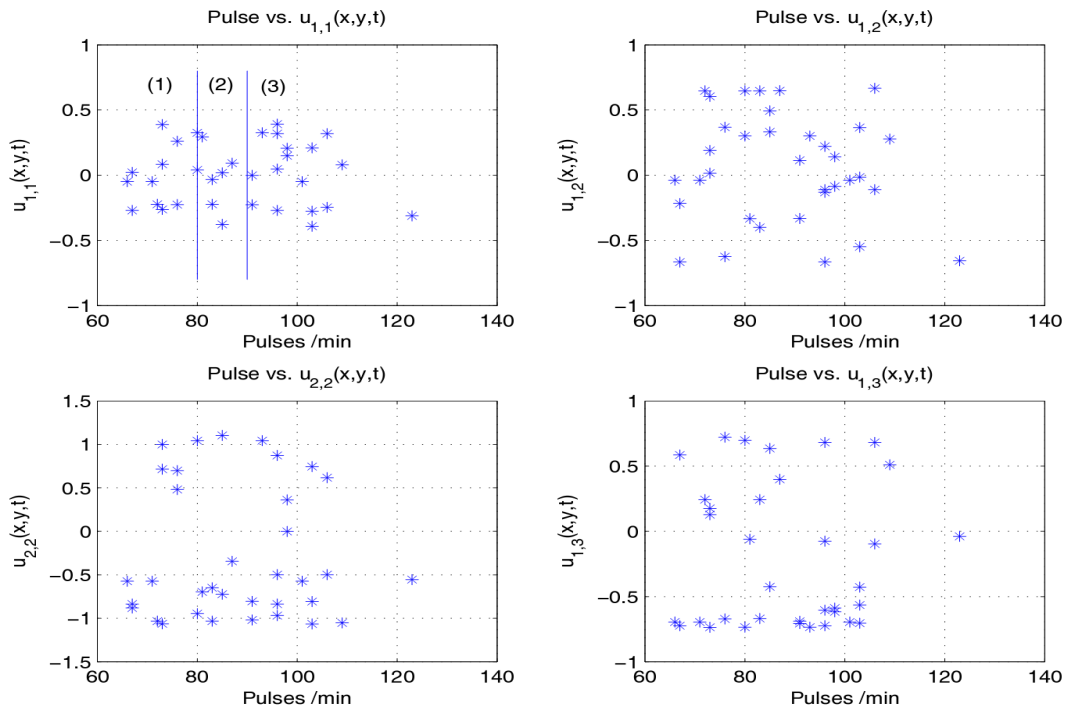


Figure 11 – The samples taken based on pulse variations caused by stress

**References**

- [1] T.L. Nwe, S.W. Foo and L.C. De Silva, "Detection of stress and emotion in speech using traditional and FFT based log energy features", Proceedings of the Joint Conference of the Fourth International Conference and the Fourth Pacific Rim Conference on Multimedia, Information, Communications and Signal Processing, Vol. 3, p 1619 - 1623, Dec. 2003.
- [2] M. Yamaguchi, et al, "Salivary amylase activity monitor used for stress evaluation", Proceedings of the 25th Annual International Conference of the IEEE Engineering in Medicine and Biology Society, Vol. 4, p 3075 - 3078, Sept. 2003.
- [3] Hirokazu Ogino, Haruyuki Minamitani and Takeshi Souma, "Reflectance Pulse Oximeter Measuring Central SaO<sub>2</sub> from Mouth", Proc. Annual International Conference of the IEEE Engineering in Medicine and Biology Society, Vol. 2, p 914-915, Baltimore, Maryland, USA, Nov. 1994.
- [4] Mi-Hee Lee, Gyunghye Yang, Hyoung-Ki Lee and Seokwon Bang, "Development Stress Monitoring System based on Personal Digital Assistance (PDA)", Proc. Of the 26th Annual International Conference of the IEEE Engineering in Medicine and Biology Society, Vol. 1, p 2364-2367, San Francisco, California, USA, September 2004.
- [5] J.W. Shin et al., "Estimation of Stress Status using Biosignal and Fuzzy Theory", Proc. Of the 20th Annual International Conference of the IEEE Engineering in Medicine and Biology Society, Vol. 3, p 1393-1394, Hong Kong Sar, China, October 1998.
- [6] Murad Shibli and Mohammad S. Sharawi, "Modeling and Characterization of A Mechatronics System for Human Stress Detection", IEEE International Conference on Signal Processing and Communications (ICSPC 2007), p 872-875, Dubai, UAE, November 2007.
- [7] 1865 Infusion Pump Pressure/Force Sensor, SensorTechnics Inc., Data Sheet, 2004.
- [8] Piezo-Electric Transducer, eDAQ Pty. Ltd., Data Sheet, 2003.
- [9] Erwin Kreyszik, Advanced Engineering Mathematics, 8th Edition, Wiley, 1999.
- [10] PIC16F87XA Enhanced Flash Microcontrollers, Micro Chip Technology Inc., Data Sheet, 2003.
- [11] Micro C 6.2 compiler manual, Micro Electronica Inc., 2005.
- [12] J. Healey and R. Picard, "Smart Car: detecting driver stress", Proc. 15th International Conference on Pattern Recognition 2000, pp.218-221 vol.214
- [13] T.G.M. Vrijkotte, et al., "Effects of work stress on ambulatory blood pressure, heart rate, and heart rate variability", Hypertension, vol. 35, no. 4, 2000, pp. 880-886.
- [14] U. Lundberg, et al., "Psychophysiological stress and EMG activity of the trapezius muscle", International Journal of Behavioral Medicine, vol. 1, no. 4, 1994, pp. 354-370.
- [15] L. Bernardi, et al., "Physical activity influences heart rate variability and very-low-frequency components in Holter electrocardiograms", Cardiovascular Research, vol. 32, no. 2, 1996, p. 234.
- [16] M. Malik, et al., "Heart rate variability: standards of measurement, physiological interpretation and clinical use", Circulation, vol. 93, no.5, 1996, pp. 1043-1065.
- [17] G.G. Berntson, et al., "Autonomic determinism: the modes of autonomic control, the doctrine of autonomic space, and the laws of autonomic constrain", Psychological Review, vol. 98, no. 4, 1991, pp.459-487
- [18] R.W. Backs, "An autonomic space approach to the psychophysiological assessment of mental workload", Stress Workload and Fatigue Human Factors in Transportation, Lawrence Erlbaum Associates, 2001.
- [19] Mohammad Sharawi, "Design and implementation of a human stress detection system: A biomechanics approach", IEEE Proceeding of the 5<sup>th</sup> International Symposium on Mechatronics and its Applications (ISMA08), Amman, Jordan, May 27-29, 2008.
- [20] J. Choi and R. Gutierrez-Osuna, "Using Heart Rate Monitors to Detect Mental Stress", IEEE computer society, 2009 Body Sensor Networks.
- [21] Markus J. Rantala, Fhionna R. Moore, Ilona Skrinda, "Evidence for the stress-linked immunocompetence handicap hypothesis in humans", Nature Communications, 2012.
- [22] DeBruine, L. M., Jones, B. C., Crawford, J. R., Welling, L. L. M. & Little, A. C. The health of a nation predicts their mate preferences: cross-cultural variation in women's preferences for masculinized male faces. Proc. R. Soc. B 277, 2405–2410, 2010.
- [23] Burns, V. E. & Gallagher, S. Antibody response to vaccination as a marker of in vivo immune function in psychophysiological research. Neurosci. Biobehav. Rev. 35, 122–126, 2010.

9/2/2012

## Investigation of the upper Khamiformationsin MahshahrNo.1 well and Hendijan No.6 well with use of well logging

FatemehAbedini<sup>1</sup>, JavadTabatabaei<sup>2</sup>, Ali Amiri<sup>3</sup>

<sup>1</sup>. Islamic Azad University, Zarand branch, Msc student of petroleum geology

<sup>2,3</sup>. Islamic Azad university, Zarandbranch, Department of Geology, Zarand, Iran  
tabatabaei@iaumeymeh.ac.ir

**Abstract:** Khami group with thickness more than 1500 meter, in Dezful Embayment separated from Bangestan group by Kazhdomi shale formations. Dezful Embayment is an structuralreality in the southwest of Zagros mountains range, that it contain almost of Irans oil fields. The upper Khami group make up carbonate formations Such as: Fahliyan, Gadvan and Dariyanwith Aptian- Neocomian age.The Hendijan Field is located in the north of Persian gulf and near beach. Mahshahr anticline is located in the north border of Persian gulf in the northern Dezful.Hendijan anticline is located in the east and Tango anticline in the north of Dezful zone. Informations of logs help to understand of useful parts, thickness and depth of reservoir, presence of water, oil and Gas in the formation and prediction of hydrocarbon reserves. The first, Corrections must execute on the digital datas that is published by National Iranian Oil Company, before they load in Excel software. Excel software is an applied software by user in order to calculations and finally, for estimations of parameter, that used in this study.In this study usedinformation of petrology, formation temperature and characteristics of drilling fluids, such as: the resistance of formation water and mud filtrate. Shale volume is calculated after determinationof gamma index by use of CGR log.Porosity logs such as: Neutron, Density and Sonic used for calculation of porosity by one or two logs. For calculation of water saturation, important equation of Archie for carbonate rocks, and for determination of Lithology, combination of Neutron and Density logs are used. Investigation of changes in porosity, shale volume and water saturation ofDariyan formation in two reservoir of Hendijan and Mahshahrshows, Dariyan formation in Hendijan well have better quality than Dariyan formation inMahshahr well because of less shale and water saturation. With comparison of these parameters, we can conclude that the Khalij member of Gadvan formation in Hendijan reservoir have better reservoir quality than Mahshahr reservoir due to high porosity and less shale and water saturation. Regarding to lowlow porosity ofFahliyan formation in both of reservoir and high shale volume and water saturation, there is not quality differences between Hendijan and Mahshahrreservoirs.

[Fatemeh Abedini, Javad Tabatabaei, Ali Amiri. **Investigation of the upper Khamiformationsin Mahshahr No.1 well and HendijanNo.6well with use of well logging.** *Life Sci J* 2012;9(3):2647-2652] (ISSN:1097-8135).  
<http://www.lifesciencesite.com>. 385

**Keywords:** reservoir quality, shale volume, porosity, water saturation, Khami group, well logging

### 1. Introduction

Because there is giant oil and gas basins, Zagros is considered as one of the most important petroleum basins in the world. The absent of igneous activities, existence of excellent source rockswith rich organic matter, porous reservoir rocks with variable permeability and appropriate cap rocks provide ideal conditions for accumulation and production hydrocarbons.It is caused Zagros zoneconsidered as one of the biggest oil and gas province in the world [2]. Because Khami group is very deep in Dezful embayment, drilling and access to it,s reservoirs has several difficulties. Like drilling wide jet wells in Gachsaran formation, pass through extremely fractured Asmari and Bangestan formations specially in regions that have gaseous lime stone.Because of these problems, many drillingisn't done in Khami group of Dezful Embayment.Hence our information about each of petroleum reservoirs isn't more of several wells data[9].

Khami group with thickness over than 1500 meter separated from Bangestan reservoirs by Kazhdomi shale formation in Dezful Embayment[8]. Carbonates in Jurassic and early Cretaceous are known as Khami group in Iran. First nomination is done by Strong and Falcon that is includemassiveand thin layer limestones in high rocks of khami mountain in the northeast of Gachsaran oil field in the southwest of Iran.

Khami group is divided to five formations, contain of: Surmeh, Hith, Fahliyan, Gadvan and Dariyan. SurmehandHithbelong to late Jurassic and Fahliyan, Gadvan and Dariyanbelong to early cretaceous[21]. Yet, more of observation on Khami group, are include stratigraphy, sedimentology, sedimentary environments and microfacies studies are done by various researchers inside and outside of Iran, but, in relation tointerpretation of logging charts and quality evaluation of reservoir aren't done any

studies in these formations specially two told reservoirs.

## 2. Material and methods

### 1-2. Studying area

Dezful Embayment is a structural reality in the southeast of Zagros thrust that it include majority of Iran oil and gas fields. Generally, Dezful Embayment belong to part of Zagros that, Asmari is without outcrop there. Dezful Embayment is located between three important structural zones, it restricted in the north to flexure zone of Baba Rood with east – west trend, and in the northeast limit to Jebhe Kohestan flexure with northwest – southeast trend, and in the east – southeast limit to a complex flexure zone and southern fault with north – south strike [8].

Hendijan field is located in the northern part of Persian gulf and near beach. This field is located in the north of Bahregansar field, in the east of Mahshahr field and the southwest of Tango and Rage Sefid fields, too, it has northern – southern trend. Distance of 6-Hendijan well until Hendijan city is about 16/5 kilometers [4]. Mahshahr anticline is located in the northern border of Persian gulf in the region of northern Dezful. Hendijan anticline is located in the east and Tango anticline is located in the north – northwest of Mahshahr [10]. Mahshahr anticline strike is north-northwest to south-southeast.

### 2.2. Studying of formations in the region

**Dariyan formation:** Its name get from Dariyan village situated in the south of type section. This formation had been call Orbitoline limestone, Albian – Aptian limestone and it has consider as Khami group, too. Type section of Dariyan carbonate formation has been measure in Gadvan mountain, exactly in the north of Dariyan village [8]. Dariyan formation exist in many areas expect south and southeast of Lorestan province. In this area, Dariyan carbonate formation has been changed to Garoo shale facies. In the upper part of Dariyan formation in often region of Fars province, has been recorded unconformities [7]. This unconformity disappeared to middle Fars and Dezful embayment side. This formation change to garu formation in the southwest of Lorestan. In coastal Fars and Khuzestan province, there are observation that show unconformity in the upper layers of this formation (top of Dariyan formation) [1].

**Gadvan formation:** The type section of this formation has been chose in the eastern of Gadvan mountain that is located in 39 kilometer east – northeast of Shiraz. The lower part of this formation with Fahliyan formation is concordant and traditional [8]. Gadvan formation is located in depth of 4512-

4391 meters of Mahshahr well, and contain alternation of gray – brown argillaceous – Silty limestone and dark gray shale [13]. Gadvan formation is located in depth of 3423-3545 meters of Hendijan well and it has been made of soft gray marls and sometimes calcareous, and gray to light gray claystones [4].

**Fahliyan formation:** The type section of this formation located in southern side of Dal mountain, near Fahliyan village and in 20 kilometers east – southeast of Gachsaran city in Fars region. Fahliyan formation include 365 meter of brown to gray massive limestone [8]. This formation is located in depth of 2012 – 4512 meters Mahshahr well and its thickness is about 500 meters [13]. Chiefly, it contain clay limestone, compact, hard and cream limestone and sometimes stylolite limestone. Generally, Fahliyan formation is considered a calcareous unit between Hith and Gadvan formations. This formation has most distribution in Fars province, but it observe in the north east of Dezful Embayment and in Lorestan province, too. Fahliyan formation laterally change to shale and clay limestones of Garu formation in the central region of Lorestan and Dezful Embayment. These changes are gradual and interfingering [8]. Fahliyan formation separate from Surmeh formation by Hith Anhydrite in the border of Fars province [1].

### 3. Research method

Carbonate reservoirs have high heterogenesis, common type of these rocks product 25-30 percent of oil in place by ordinary recovery methods [18]. One of methods of the reservoir evaluation is use of petrophysical features and well logging. Logging charts provide essential information for quantity evaluation of Hydrocarbon, rock type and fluid characterisations inside them, too. Running logs in the well, have information that determine reservoir features, indirectly. Remarkably, information get from logs help to recognition of the reservoirs pay zones. Thickness and depth of them, determine of oil, water and gas in the formation and estimate of hydrocarbon reserves. Because petrophysical features of formation aren't directly measurable, thus, they must be concluded by other parameters of reservoir rocks such as: electrical resistance, density, sound transmit time, Radioactive and amount of Hydrogen [20]. Development of reservoir facies in sedimentary rocks result of sedimentation in continental shelf until continental slope and sedimentation of Fahliyan formation in this position and change to the deep impermeable facies toward Lorestan provide conditions for make of oil reservoirs. Therefore study of stratigraphy, sedimentology and petrophysical evaluation of

these reservoirs is very important for recognition of region with the best reservoir quality in the Embayment of the northern Dezful. Some of this aim has been done in this research.

Goal of this research is survey of logging charts in the 1. Mahshahr well and the 6. Hendijan well for determination of reservoir features of the formation such as: porosity, permeability, shale volume and etc.

### 3.1. Calculation methods of parameters and data analysis

#### 3.1.1. resistance of formation water ( $R_w$ )

Accurate knowing of formation water resistance for determination of correct amount of saturation degree of a reservoir is necessary. There are several ways for correct calculation of formation water resistance [3]:

- A) calculation of ( $R_w$ ) by special chart (Schlumberger Gen-9) that in this chart, formation temperature is located against formation salinity and ( $R_w$ ) is calculated.
- B) We can determine ( $R_w$ ) in the clean zones and saturated of water, then consider the least quantities as ( $R_w$ ).

$$FR_w / R_t = FR_{mf} / R_{xo} \Rightarrow R_{xo} / R_t = R_{mf} / R_w \quad (1)$$

$$R_w = (R_t R_{mf}) / R_{xo} \quad (2)$$

#### 3.1.2. Calculation of formation real resistance ( $R_t$ )

Formation real resistance is related to uninvaded zone. Resistance logs with high survey depth measure this resistance. With having measured resistances in various depths of the formation contain: ( $R_{xo}$ ) = (resistance of flushed zone), ( $R_{IIS}$ ) = (total resistance and of invaded and transition zone) and ( $R_{IID}$ ) = (total of invaded, transition and flushed zone resistance), we can get ( $R_t$ ) by several ways [3]:

A) by having ( $R_{IID}$ ) and ( $R_{IIS}$ ), we can calculate the real resistivity of the formation by the down experimental formula:

Relation (3), while it is:

$$R_{mf} \langle R_w R_t = 1.7RLLD - 0.7RLLS$$

Relation (4), while it is:

$$R_{mf} \rangle R_w R_t = 2.4RLLD - 1.4RLLS$$

B) other way, is use of Tornado chart, with having ( $R_{IID}$ ) and ( $R_{IIS}$ ) and ( $R_{MSf}$ ).

#### 3.1.3. Calculation of porosity

Porosity is the percent of void volume ratio to total volume ( $\phi = v_p / v_t$ ) and it may create two forms:

1. The primary or contemporary with sedimentation and
2. The secondary or after sedimentation.

The porosity is without dimension and express with percent. In order to calculation of porosity is used porosity logs like: Neutron, Density, Sonic and usually the porosity is calculated by one or two log [15].

For years, The sonic log has been an ordinary tool for the porosity calculation because it had the less sensitivity to the changes of well walls and mud cake. But compound of Neutron and Density logs is considered as source for calculation of the porosity latterly [14]. Neutron and Density logs is used for calculation of the total porosity and sonic log for primary porosity that we can get secondary porosity of difference between those [3].

#### 4.1.3. Shale volume

The existence of shale in Hydrocarbon reservoirs, has much effect on estimation of reserve and production ability. Shales do not have constant mineralogy but clay mineral, quartz, feldspar, carbonates, amorphous silica, pyroclastic and organic matter are major constituents. Calculation of the shale volume from logging data for exact estimate of porosity and saturation is necessary [3]. If influence of the shale volume don't survey in the formation, visible influence will have on the results of water saturation, permeability and porosity of the reservoir [17], because clay minerals for having microporosity effects on petrophysical features (permeability, porosity, saturation). Existence of clays in reservoirs cause to decrease of electrical resistance of the rock and create unreal results in the saturation and porosity calculation. Thus, estimating of shale volume and its impacts is very essential [3].

There are several ways for calculate of shale volume [3]:

A) The ways base on logs that its response to shale volume, primarily and were known as shale indicators.

B) The ways base on logs that shale percentage isn't first effective parameter but influences on log response in various ways.

#### 5.1.3. Calculation of water saturation ( $S_w$ )



Generally, water saturation is the water volume in the pores in contrast with total volume of water that determine with percent and its symbol is ( $S_w$ ) [5]. Actually, the content of the fluid saturation in porous environment is include water saturation ( $S_w$ ), oil saturation ( $S_o$ ) and gas saturation and the total of those in the rock equals one.

Generally, all of ways of water saturation calculation base on Archie method and laboratory measurements in the years 1941-1942 established, and water saturation depend on the porosity, electrical resistance, formation resistance factor, shale volume, shales resistance and ionic balance capacity of the clay minerals in the all ways. but, sometimes water saturation related to velocity. Because, the fluid content influence seismic waves speed, extremely [16].

The Archie equation is used among told important relations for saturation water calculation. This relation is used for sandstone and carbonates that has been expressed below:

Relation (5)

$$S_w = \sqrt{\frac{FR_w}{R_t}}$$

In this relation ( $S_w$ ) equals water saturation ( $n$ ) is saturation coefficient and ( $n$ ) equals two ( $n=2$ ). ( $R_w$ ) is formation water resistance and ( $F$ ) is formation resistance factor and ( $F$ ) obtain of below relation:

Relation (6)

$$F = \frac{a}{Q^m}$$

In this relation ( $a$ ) is tortuosity coefficient and ( $Q$ ) is porosity and ( $m$ ) is cementation coefficient and it consider as pores figure factor recently.

Usually, ( $a$ ) equals one ( $a=1$ ) and ( $m$ ) equals two ( $m=2$ ) in carbonates, and ( $a$ ) equals 0.81 ( $a=0.8$ ) and ( $m$ ) equals two ( $m=2$ ) in consolidated sandstones and ( $a$ ) equals 0.61 ( $a=0.61$ ) and  $m$  equals 2.15 ( $m=2.15$ ) in not consolidated sandstone, is considered [3].

### 6.1.3. Calculation of water total volume:

Water total volume is water saturation ( $S_w$ ), multiply porosity ( $Q$ ) [5].

$$BVW = S_w \times \varphi$$

If the calculation contents (BVW) are fixed in various depths, it shows a homogenous layer and it will stand in the position of irreducible water saturation. So, present waters in univaded zone aren't able to movement because capillary force by rock particles prevent of flow. Thus Hydrocarbon production do without water in zones that are located in irreducible water saturation [19]. A formation, doesn't stand in position of irreducible water saturation, shows different content of (BVW).

The content of water that a formation can retain by capillary power, depend on particles size. With decrease of particle size, capillary power and (BVW) increase in rocks. Thus, we can use from amount of (BVW) for recognition of various porosities, as indicator in carbonate rocks [12].

Table 1: Relation between bulk volume water and porosity types [5].

bulk volume water (BVW)	Carbonates
0/005 - 0/015	Vug
0/015 - 0/025	Vug and Intercrystallin (Intergranular)
0/025 - 0/04	Intercrystallin (Intergranular)
BVW > 0/05	Chalk

Table 2: Relation between bulk volume water and decrease particle size [5].

bulk volume water (BVW)	Particle size (millimeter)
0/02 - 0/025	5- 1 Coarse
0/025 - 0/035	0/25 - 0/5 medium
0/035 - 0/05	0/125 - 0/25 Fine
0/05 - 0/07	0/0625 - 0/125 Very fine
0/07 - 0/09	<0/0625 Silt

### 7.1.3. Determination of lithology by use of logs:

One of the important usage of logs is determine of lithology. Lithology features, that influence on logs, are mineralogy, texture, structure, shale bulk, fluids content [3]. For determine of lithology, the best spot is place, that have the least shale bulk and porosity and is saturated of water. It cause Hydrocarbon affect on logs response get minimum [11].

We can use of two or three logs for determine of lithology.

### 8.1.3. Velocity – Deviation log

Velocity – Deviation log generate from combination of sonic with Neutron or density logs. This log is mapped as velocity- Deviation log by conversion porosity chart data to artificial velocity.

There are two ways for calculation of velocity – deviation log:

- 1) VDL calculation by usage of Sonic and Neutron log.
- 2) VDL calculation by usage of Sonic and density log.

Generally, we can record type of porosity by deviations this log to left (negative extent) or right (positive extent).

#### 4. Discussion and conclusion

##### Comparison of Dariyan formation in two field of Mahshahr 1 and Hendijan 6:

By study of changes amplitude [6] in Dariyan formation in two reservoirs, we can consider 10% porosity as weak porosity in Dariyan formation. Other aspect is shale bulk that respectively, shale content is 12% and 23% in Hendijan and Mahshahr in Dariyan formation, thus the content of shale bulk in Dariyan formation of Hendijan is lesser than Dariyan formation of Mahshahr. Content of saturation is 59% and 72% in two reservoir of Hendijan and Mahshahr, respectively, that it shows less water saturation content of Dariyan formation in Hendijan reservoir. Thus with compare this of 3 parameters, can consider Dariyan formation in Hendijan well have more quality than Dariyan formation in Mahshahr well.

##### Comparison of Gadvan formation (Khalij member) in Mahshahr 1 and Hendijan 6 reservoir:

By study of changes amplitude [6] in Gadvan formations in Mahshahr and Hendijan reservoirs that they respectively have 12% and 26% porosity, based on reservoir quality, porosity in Mahshahr well is medium and Hendijan well is good. Respectively, the content of shale in Hendijan and Mahshahr reservoirs is 3% and 13% that it is a low shale average. Water saturation is 60% and 40% in Mahshahr and Hendijan reservoirs, respectively. Thus with compare of 3 parameters, can conclude that Khalij member of Gadvan formation in Hendijan reservoir has more quality than Mahshahr reservoirs.

##### Comparison of Fahliyan formation in Mahshahr 1 and Hendijan 6 reservoirs:

By study of changes amplitude [6] in Fahliyan formation in Mahshahr and Hendijan reservoirs, that they respectively, have 7% and 6% porosity and it consider a weak porosity. respectively, shale average is 11% and 18% in Mahshahr and Hendijan reservoirs. Thus shale average is low in both reservoirs. Thus with comparison of these parameters conclude quality is equal at two reservoirs.

#### Evaluation of logs of Dariyan, Gadvan and Fahliyan formation provide many information about porosity and shale volume.

By done studies on formations in Mahshahr and Hendijan reservoirs, each of formations separated to zones:

1. Respectively, Dariyan, Gadvan and Fahliyan formation have been separated to 9,10,15 zones in Hendijan reservoir.
2. Respectively, Dariyan, Gadvan and Fahliyan formation have been separated to 12,7,13 zones in Mahshahr reservoir.

- Analysis of well logging data shows porosity is weak in Dariyan and Fahliyan formation and shale content is low.
- Because sonic chart just measure background porosity and Neutron and density charts calculate total porosity of rock, sonic chart hasn't been considered in calculations.
- Khalij member of Gadvan formation in Hendijan reservoir with porosity content equals 26% and saturation equals 41% and shale volume equals 3% has more reservoir quality than the Khalij member of Gadvan formation in Mahshahr reservoirs with porosity average equals 12% and water saturation equals 60% and shale volume equals 13%.

#### Acknowledgment

This paper has been extracted from the research project and its done by the financial support of NATIONAL IRANIAN OIL COMPANY, MANAGEMENT OF PRODUCTION AND EXPLORATION, and MANAGEMENT OF RESEARCH AND DEVELOPEMENT. The authors is deeply grateful to their help.

#### References

1. Khosro Tehrani, Kh, (1360), Facies sedimentary in tin section, Tehran university publication, page 195.
2. Darvishzadeh, A, (1370), Geology of Iran, Neda publication.
3. Rezaee, Mohammad, R and Chehrazi, Ali, (1385). Well logging interpretation and deduction elements, page 699. Tehran university publication.
4. Shah Hoseini, Kourosh, (1386). Oil engineering complementary report of Hendijan well.
5. Seyrafian, Ali, (1372). Basic well log analysis for Geologists, page 212. Esfahan university publication.

6. Tabatabaei, Javad, (1384). Petroleum engineering, page 324 – negaresheolum publication.
7. Ghalavand, Hormoz, Lithostratigraphy and Biostratigraphy in the formation Dariyan and Kazhdomi, Shahid Beheshti university, page 290.
8. Motiee, Homayoon, (1372). Geology of Iran, Zagros stratigraphy, Geological survey of Iran.
9. Motiee, Homayoon, (1374). Zagros oil geology, Geological survey of Iran.
10. Maleki, Asadolah and Niktabie, Mohammad, R(1381). The exploratory well complementary report of Mahshahr.
11. -Asquith, G.B. and case, C.R., (1983), CNT-A dolomite response, Trans. spwla 24<sup>th</sup> Annual logging symposium, papers.
12. -Asquith, G. And D. krypowski, (2004), basic well log analysis: AAPG methods in Explorations series, no.16.244p.
13. Bahrami, H., (2001). Biostratigraphy and Micropaleontological studies on the cutting samples of Mahshahr No.1.
- 14-Dewan, J,T., (1983), Essentials of modern open – Hole log interpretation, penn well publishing company, Tulsa.
15. Kharkwal. G et al., (2012), Taxonomic Diversity of Understorey Vegetation in Kumaun Himalayan orests, life science journal. 9(2)
16. Hearts, J,R., Nelson, P,H., Andpaillet, F,L., (2000), well logging for physical properties, John wiley & sons, ltd, chilchester.
17. Kamel, M.H., Mabrrouk, W.M., 2002, Anequation for estimation water saturation in clean formation untilizing resistivity and sonic log:theory and application, Journal of petroleum science and engineering, V.36,pp.159-168.
18. Lucia, F.J. (1999): carbonate reservoir characterization, springer –rerlog Berlin, Heindberg, Germany, 226p.
19. -Lashin, A., Linder (Freiberg), (2002), H., Abu Ashor, N., sharf El Dien, M., Zahra, h., Hydrocarbon potentialities and sourse rock recognition in the area north of octobr field – Gulf of suez –Gulf of suez – Egept. 2,3 p.
- 20.-Morris, R.L., and Biggs, w.p., (1967), using log – derived values of water saturation and porosity: spwla, 8<sup>th</sup> annual logging symposium transactions, paper 0.
- 21-Schlumberger, (1989), Schlumberger log interpretation charts, Houston, texas.
- 22- Setudehnia,A, (1972), Lexiquesteratigraphy International ASIE v. Fascicule 96.2 Iran du sud quest.

9/9/2012

## Stones of British Colonial Lahore: A study of two Remarkable Buildings of earlier period of British Colonial Architecture

Arif Khan<sup>1</sup>, Sabahat Arif<sup>2</sup>, Abdul Rehman<sup>3</sup> and Khalid Alamgir<sup>4</sup>

<sup>1,2,3</sup> Department of Architectural Engineering and Design, University of Engineering & Technology, Lahore

<sup>4</sup>National Institute of Vacuum Sciences

[sabahatarif@hotmail.com](mailto:sabahatarif@hotmail.com)

**Abstract:** Among many miles stones of British Raj in Lahore, the Lawrence and Montgomery Halls, presently known as Quad-e- Azam Library are the master pieces of earlier period of British architecture in Lahore which were constructed with the subscriptions of British and Indian communities of the Punjab, as memorial in the honor of two European commanders of British Indian Empire. These buildings have been greatly surviving for the last 149 years and still hold prominent position in building stock of Lahore. To find out the reasons behind the longer survival of these remarkable British colonial buildings in Lahore, this paper explores the architectural design, structural scheme, adaptive reuses and the main driving forces behind the origin of Lawrence and Montgomery Halls. The paper concludes that it is not only the flexibility in architectural planning, structure stability and acceptance of building form which keeps the major architectural and structural intervention away from the buildings but suitable selection of adaptive reuses related to the original functions of the building can also play a vital role in sustainability of older buildings.

[Arif Khan, Sabahat Arif, Abdul Rehman and Khalid Alamgir. **Stones of British Colonial Lahore: A study of two Remarkable Buildings of earlier period of British Colonial Architecture.** *Life Sci J* 2012;9(3):2653-2659] (ISSN:1097-8135). <http://www.lifesciencesite.com>. 386

**Keywords:** Lahore, Lawrence and Montgomery Halls, Quaid Azam Library, Adaptive Reuse, Colonial Architecture, Colonial Stone, Standard Design.

### 1. Introduction

Lawrence and Montgomery Halls presently known as Quaid - e - Azam Library are located in the premises of Jinnah Garden (the then Lawrence Garden) at Lower Mall Road (the then Mian Mir Road) Lahore. The main driving forces for creation of these buildings were “emotions and sentiments” of European and Indian communities of Punjab to acknowledge the service of two European commanders of Indian Empire namely Sir John Lawrence (Governor General and Viceroy of India from 1864 to 1869) and Sir Robert Montgomery (the first Lieutenant Governor of the Punjab from 01-01- 1859 to 25-02-1859), for their contribution to the British Indian Empire generally and betterment of the Punjabi people particularly. Beside European community of the Punjab, the Indian force of Rajas Maharajas, Nawabs from Punjab, Kashmir and other areas of India was remained in front to arrange the funds for the conversion and depiction of their feelings into physical form through a building to serve as memorial to attribute Sir Lawrence and Sir Montgomery. The construction cost of Lawrence Hall was Rs 34000 whereas Rs 174,000.00 was spent on construction of Montgomery Hall including the cost of Rs 66,000 for its re-roofing and renovation during the year 1875 (Latif, 1892) .

Lawrence Hall was built as memorial during the life of Sir John Lawrence (1811-1879) who started his service in India from Assistant District Officer in Delhi

and after serving at different posts finally attain the position of Governor General and Viceroy of India (1864 - 1869). Soon after the annexation of Punjab he served as member for Board of Administration in Lahore (1849-53) which was headed by his elder brother Sir Henry Lawrence. During the period of 1853-58 he held the position of chief commissioner of the Punjab and later on became the first Lieutenant Governor of the Punjab (01-01- 1859 to 25-02-1859). In lieu of valuable services rendered to British Indian Empire by him, he was decorated with the awards of G.C.B (Knight Grand Cross of the Bath) and G.C.S.I (Knight Grand Commander of the Star of India). In addition to construction of a Memorial in Lahore namely “Lawrence Hall”, three statues were also erected to him in Calcutta, Lahore (Mall road) and London (Buckland, 1905).

In the office of the Lieutenant Governor of the Punjab sir John Lawrence was replaced by Sir Robert Montgomery (1809-1887), Roy, 1914. According to Buckland (1905), Sir Robert Montgomery served for long time in India. He joined Bengal service in 1828, Magistrate Collector at Allahabad in 1839, commissioner of Lahore in 1849, member Punjab Board of Administration in 1851, Judicial Commissioner 1853, chief commissioner of Oudh 1858, second Lieutenant Governor of the Punjab 1859-1865 and finally member of the council of India from 1868-1887. He was decorated with K.C.B (Knight

Commander of the Bath) in 1859, G.C.S.I (Knight Grand Commander of the Star of India) in 1866. On the basis of his commendable polices and outstanding working, he always remained favorite personality before the people of Punjab which resulted construction of one memorial namely "Montgomery Hall" during his life nearby Lawrence Hall, Lahore .

Lawrence and Montgomery Halls were designed by the chief engineers of Public Works Department namely Mr. G. Stone and Mr. J. Gordon, respectively (Kunhya,1877). The construction of these buildings were completed under the supervision of Rai Bahaduar Kunhya Lal, who was serving as Executive Engineer in Lahore under Public Works Department (P.W.D) of the Punjab. Two Indian namely Muhammad Sultan and Lala Mela Ram were employed as contractors for Lawrence and Montgomery Halls respectively (Abbass, 2001). Halls were constructed during different times and these were connected through a closed 18 feet wide corridor. There is much dispute on the construction dates of these halls. The most reliable source in this regard is the articles written by Rai Bahaduar Kunhya Lal on these buildings in 1877 where the years of construction for Lawrence and Montgomery Halls are reported as 1862 and 1866 respectively. Later on Syed Muhammad Latif had mentioned the same dates in his book written on history of Lahore in 1892. Although Latif had not given any reference to Kunhya Lal but the details related to halls in his book reveal that the article of Kunhya Lal, published in 1877 was just reproduced. According to marble tablets fixed on the wall of entrance lobby of Montgomery Hall the construction date of this Hall is 1867. According to "London News" the construction of Lawrence and Montgomery Halls was completed in 1861-62 and 1866 respectively (The Illustrated London News,1864,1866). In 2001, Abbass Chughtai reported that Lawrence Hall was built in 1863 and Montgomery Hall in 1867. He supported his argument with Punjab Government Home department's proceeding No.10 of 25th July 1863 and mentioned that contractor of Lawrence Hall, Muhammad Sultan had written a letter to secretary of government Punjab on 15th July 1863 wherein the delay for completion of hall was explained and it was assured that building will be completed before the arrival of the Governor of the Punjab in Lahore (Abbass, 2001). It might be the final finishes which were not completed for which contractor wrote letter to secretary Punjab. However, the opening ceremony of Lawrence Hall was made by Sir John Lawrence, the Viceroy of India on 17-10-1864, to whom the building was attributed. Sir Robert Montgomery, the then Lieutenant Governor of the Punjab was also present on the occasion. After completion, the Halls became the largest one in Lahore with all modern facilities and were used for variety of activities including social gathering, public meetings,

theatrical entertainments, musical performances and durbars which defines the multifunctional dimensions of the halls and flexibility in architectural spaces. The decision to establish Mayo School of Art and Atchison College in Lahore were also taken in the meetings held in these halls. The Halls were also used for two meetings of Punjab Legislative Council, examination, meetings of Senate and annual convocation of Punjab University. Duke of Edinburgh also visited these halls in 1870 and besides a grand function in his honor the dancing party was also arranged in Montgomery Hall. Mian Mir Institute was established in these Halls in 1878 and a large collection of books from Anarkali Book Club (housed in Wazir' Khan Baradari presently known as Punjab Public Library) and Station Library (previously housed in Soldier Garden) was transferred to this Institute. In 1906 when responsibility of repair and maintenance of Halls was transferred to Punjab Government from Municipal Committee then halls were taken on lease by Gymkhana Club and instead of 'Lahore and Mian Mir Institute' it was started to be known as Gymkhana Club. In 1972 the Gymkhana Club was shifted to a new building near Bari Doab Canal on Upper Mall Road which started its construction in 1968. In 1981 it was decided to establish a model library in Lawrence and Montgomery Halls. A committee under the chairmanship of Chief Secretary Punjab was constituted on 17th May 1980 to work on the project (Abbass, 2001). The Governor Punjab, Lt. Gen. Jilani Khan took keen interest in establishing the library and finally on 25th December 1984 the official inauguration was made by Gen. Muhammad Zia ul Haq, the President of Pakistan. Since that time the Lawrence and Montgomery Halls were known as Quaid-e- Azam Library.

Although the adaptive reuses of these buildings have much similarity to the original functions of the buildings but the memorials which were built to acknowledge the services of two British commanders of Indian Empire had been renamed in 1984 from Lawrence and Montgomery to Quaid- i-Azam Library, which resulted to place the buildings away from their original context to act as memorials. However, the role of architectural scheme, structural system and adaptive reuses for longer survival of these buildings are discussed in the following sections.

## 2. Architectural Aspects

The Lawrence Hall fronting the Mall Road from its longer axis measures internally 32'-5" x 65' and externally 37'-5" x 70' whereas Montgomery Hall is facing the central avenue of Jinnah Garden the formerly called Lawrence Gardens through its longer axis and hall measures 46' x 106', 92' x 152' from internally and externally respectively. Both Halls stand on a raised platform of 4'-6" from road level creating a commanding position on surrounding environment.

The Montgomery Hall covers the whole space from all sides on raised platform whereas in Lawrence Hall an open space of 13'-6" wide is provided to all sides except the rear side which is connected to Montgomery Hall through a covered corridor of 17'-3" wide and 81'-8" in length. Besides connecting both halls the corridor also provided space for reading room and pictures gallery [Fig-1].

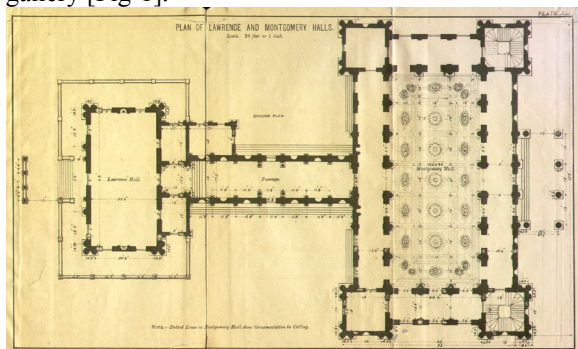


Fig-1 Plan of Lawrence and Montgomery Halls 1877

It revealed from the original drawings and old images of the Halls that a clock tower was part of whole composition, originating from the mid of the connecting corridor of the Halls. Although the tower was holding a prominent position due to its central locations between the two halls and furthermore supporting the verticality of the buildings from comparatively low height corridor but it could not survive and probably damaged during earthquake of 2005.

However, the interior designing of this gallery was accomplished by the students of Mayo School of Art presently known as National College of Arts under the supervision of their Principal John Lock Wood Kipling. Mayo school had once again worked on renovation of decorative work under the supervision of Principal Mr. Persi Brown when Kangra Earthquake of 4th April 1905 gave some damages to Montgomery Hall. Mr. Persi Brown was awarded Rs 500 against the work. During the same year the electric lights were also introduced in the Halls to make these more attractive during the visit of Prince and Princess of Wales who visited these Halls in Nov 1905. A grand function was arranged in the honor of prince and princess followed by a dance party which continued till late night on wooden floors of the halls made of deodar wood in Lawrence Hall and teak wood in Montgomery Hall. The flooring of the buildings other than halls was made with burnt hexagonal tiles laid in cement [Abbas 2001].



Fig-2 Clock Tower once existed between two Halls. Source: British Library

This symbolic architectural element of prestigious buildings of colonial period of India was not restored and buildings seem deficient of it [Fig-2].

The corridor connecting the Halls terminates from its ends at the centre of rear sides of longer axis of both Halls. In this way while standing in front of Lawrence Hall the both halls comes together in building composition which revealed that at the time of construction of Montgomery Hall the existing scheme of Architectural style of Lawrence Hall was completely followed for new building. Similarly a large basement was also constructed during the year 2010 on available space to south –west orientation of the Halls to meet the increasing demand of extension in adaptive reuses of the buildings. To make the movement ease from both halls to basement the entrance of the basement is made through the corridor connecting both halls. Furthermore, the height of the basement has been restricted to the height of the raised platform and in this way the new construction creates no disturbance in external appearance of the building. However, any future construction on basement roof shall badly affect the existing appealing views from south west sides.

The buildings were made with symmetrical composition in an efficient manner creating interest for the viewers at all level from closer as well as longer distances through small and large scale richness which still holds field around the building. Although the buildings came into existence with combined efforts of European and Indian communities of Punjab but its overall statement reflects that it was intended to reflect the classical style of architecture which was mostly in practice at that time in Europe for the buildings of such importance. The major architectural elements of buildings composition are massive walls, round arches, Greek Doric order for lofty columns, horizontal lines, pediment, small windows, balustrade and floral patterns [Fig-3].

These typical elements of European architecture with standard details had been extensively used on Exterior and interior surfaces of the buildings during colonial rule in Lahore. The deviation from standard details was strictly forbidden. These architectural elements which define the style of Lawrence and Montgomery Halls as classical, unfold that when Europeans and Indians “emotions and sentiments” for their two commanders of British Indian empire were transformed into physical form of a building, the natives’ participation could not find any space in the whole composition and remained only limited to the documentation of names on two marble tablets in the entrance lobby of Montgomery Hall. In contrast to the building style the native languages Urdu and Hindi were used to inscribe the names of Native chiefs and others to document their subscription for the memorials.



[Fig. 3 Exterior (Southern View) of Montgomery Hall .  
Photo by Authors in 2010

However, such practices were common in many memorials built during British rule in India and later on these ideas were transformed into Anglo Indian Style of architecture during the last quarter of the 19th century when Indian and European architectural elements started to appear together on buildings façades. Some important buildings of Lahore also witness the amalgam of Indian and European architectural traditions where plans were made by Europeans and exterior by natives. In fact the rich Indian built Architectural heritage and European spatial requirements in Indian climate and environment let the natives to design exterior of the buildings and European architects/engineers to make the plans of the buildings. It can be interpreted as “European and Indian Architectural friendship” emerged in the form of Anglo Indian Style of architecture which continued in many buildings of architectural importance during colonial period in Lahore and as well as in other part of the British India (Vandel, 2006) .

Like other plain areas of the British India, the climate of Lahore remained a prime considerations and a serious concern before the engineers and architects in designing of buildings for the use and occupation of European community in Lahore. To make the buildings climatically sustainable under critically conditions during summer in Lahore, various planning strategies were adopted which had already successfully worked in other plain areas of India. In result of planning against hot climate the most common features appeared in colonial buildings were thick walls, verandah, high roof, high level wall ventilators and small windows. The climatic role of these architectural elements made them essential and leading features of colonial buildings in India. Similarly in Lawrence and Montgomery Halls thickness of external walls (building envelops) was made as 30 inches thick to minimize the heat penetration inside the building during summer due to increase time lag factor. A corridor of 12'- 6" feet wide as buffer space of was provided to all sides of the Montgomery Halls to protect the main building against rain and unwanted direct solar radiations. The internal heights of the halls was made more than 58 feet to increase the volume of the buildings so that SVR (Surface-to-Volume Ratio) could be reduced resulting minimum effect of outdoor temperature on inside thermal conditions of the building (Khan 2010).

In the process of renovation of Halls by the Punjab Archaeology Department during the year 2010-11 it is observed by the author that Indian bricks of smaller size (Chotti Eent) measuring 8"x 4"x 1.5" were used in original plans of Lawrence and Montgomery Halls whereas all additions of later period were built in English bricks of size 9" x 4.5" x 3". The rooms on both ends of Lawrence Hall were constructed in English bricks and these were not given in original plan. However, in many buildings of earlier period of British rule in Lahore the English and Indian Bricks both were used side by side in the construction of buildings (Khan 2010). Kunhya Lal commenting on history of Lahore unfolds that ruins of old buildings outside the walled city were excavated deep into their foundations by many building contractors for obtaining and selling bricks on cheaper rates. These bricks of smaller size were used in many buildings of early British period in Lahore as these were ready available on cheaper rates as compare to English Bricks. Mian Muhammad Sultan the one of the contractors of Public Works Department (PWD) was famous in selling old Indian bricks. He as contractor of Lawrence Hall provided and used Indian bricks for the construction of these buildings [Kunhya ,1884].

The building external and internal walls are made of pucca bricks laid in lime mortar with lime plastered from both sides. The appearance of walls was

made different from other colonial buildings of Lahore by making white marble stone like finishes on all external surfaces of the building. The stone like finishes were achieved through providing 2.5 inches thick lime plaster layer over Indian bricks masonry and dividing it into rectangular pieces looking like natural marble stone. Each surface looking like stone was polished to create natural impression of white marble stone finishes. With all this arrangement the building once creates illusion for viewers. The exterior walls which are 60 feet high, have only small projection against rain protection therefore 2.5 thick lime plaster layer also acted as barrier against rain water penetration inside the buildings and this technique is successfully working since a long time. The uses of lime plaster and lime mortar were also common traditional practices in natives' buildings before pre colonial period in Lahore. The major ingredients of lime mortar reported in different studies during British period are 'kankar', pit-sand and 'soorkhee' (pounded bricks) but some time various substances like coarse sugar and egg shells were also added to obtain strong and fine mortar [Medley,1863]. The physical examination of old mortar used for brick masonry and walls plaster for Lawrence and Montgomery Halls reveals that its constituents are Lime and Kankar. In renovation during 2010-11, the all damaged plaster was peeled off and 2" thick new layer of lime plaster was provided on external walls and columns. The major ingredient of this mortar is fine powder of Kankar containing a large quantity of lime, lime paste and jute fibers. The mixing of Kankar and lime paste is mostly made with the ratio 2:1. The fine powder is prepared from burning of Kankar at high temperature in kiln and then it's grinding in mill.

### 3. Structural Aspects

The main vertical structural elements of both buildings such as foundations, columns, walls and arches are made of pucca brick ((burnt bricks) laid in lime mortar whereas roofing system of both cases is wooden trusses covered with lime terraced concrete in Lawrence Hall and galvanized corrugated iron sheets in Montgomery Hall. Although there is no record available on the foundations of the buildings but in view of the information available on foundations of other colonial buildings of Lahore which have almost similar magnitude and height, it is reasonable to suppose that foundations of Lawrence and Montgomery Halls would be 12 -15 feet deep with 3-5 feet lime concrete bed and above that 9-10 feet 'pucca' masonry. The exact information can be obtained through onsite investigation by means of core drilling.

The wall thickness varies at different locations from 24-36 inches depending upon load requirements. As the walls are more than 60 feet high therefore, numbers of columns were provided at regular intervals in internal and external walls which are integral part of

these walls and act as bracing member to increase the structural strength of the building under critical conditions of wind load and other loads of the building. In case of Montgomery Hall the intermediate floor of gallery further provides the bracing to buildings against lateral loads. In addition to participating in structural stability of the building the columns are effectively playing their role in aesthetic scheme of the building for interior and exterior as well. In all corners of the buildings a set of three columns are provided which strengthens these critical points and also create a pleasing impression on corners. In case of Montgomery Hall the corners are further strengthened by planning auxiliary spaces in square shape 18'x18'.

The original roof of Lawrence Hall is still working successfully. It is Deodar wooden trussed roof with ornamental flat wooden ceiling underneath and lime terraced concrete as roof covering. The original roof of Montgomery Hall (1866) was bricks vaulted roof which could not sustain and suffered much cracks and finally re-roofing of lighter construction was made in 1875 with trusses of Deodar wood overlaid with galvanized corrugated iron sheets. The new roofing was designed and executed under the supervision of Kunhya Lal, the Executive Engineer of Public Works Department (P.W.D.) Lahore. His calculations for the strength of trusses reveal that a comprehensive detailed analysis of structure was carried out to avoid any further risk of structural failure in future. The external height of the building is 69 feet-3inches therefore in addition to considering other loads the wind pressure was also taken in considerations for the design of 46 feet span truss with 8.5 feet rise. The average interval of trusses from centre to centre was taken as 5 feet. The vertical load consists of the weights of roof covering truss frames and ceiling was taken as 40 lbs/sft whereas normal load, consisting of wind pressure acting normal to roof surface, on one side of the roof at a time was considered as 30 lbs/sft. The most interesting part of truss is the wooden tie beam for 46 feet span. It was formed after jointing two wooden beams of cross section of 14" x 8" by overlapping almost 9 feet in the middle of the truss. The overlapping parts of wooden beams were jointed carefully with iron strips making attachment with king-post, Queen Post and Purlins. The dimensions calculated and implemented by Kunhya Lal for different components of truss are; Principal Rafter 10" x 8", Tie Beam 14" x 8", King Post in the middle 10" x 8", Queen Post 8" x 8", Strut 7" x 7", Purlins 6"x6", Common Rafter 3" x 2", Ridge Pole 7" x 4", Wall Plate 8"x 6", Pole 6"x4" and Purlin Blocks 12"x6" [Kunhaya, 1877]. The truss system is not visible from exterior and interior of the building. It has been completely concealed from the interior with ornamental wooden coved ceiling with colorful floral patterns and, with brick masonry parapet wall from



exterior, therefore one cannot judge about roofing system while standing inside or outside the building [Fig 4(a) and (b)]. The roof and ceiling have been generally surviving since their construction. However, the roof



Fig.4(a) Interior view of Montgomery Hall  
Photograph by Authors in 2010

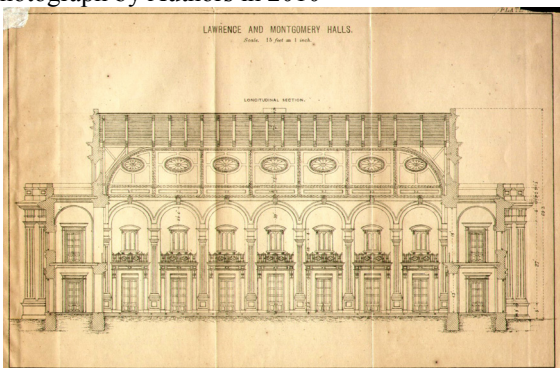


Fig.4(b) Image taken by the Original Drawings of gallery adjoining the porch was damaged partially due to the movement of porch during the Kangra Earthquake of 4th April 1905. The capital of the porch columns, keys of the arches over the gallery and ceiling of corridor adjoining the both halls were also got cracked during the earthquake (Middlemiss 1910).

#### 4. Adaptive Reuses

The buildings' stock of Lahore holds large numbers of buildings from colonial period (1849-1947) on variety of uses but the buildings purposely built for educational, health, residential, religious and public service functions are still existing and performing their original role successfully. In these types of buildings no major intervention occurred and little modifications helped the users to accommodate the requirements of the day without disturbing structural scheme and external aesthetics of the buildings. The present working condition of the buildings of such categories located in different areas of Lahore reveals that much importance was paid to them on the basis of their functional nature therefore these are regularly attaining the attention of building controlling authorities since their creation for maintenance and repair which added

more and more years to the life of these buildings. The leading examples of such buildings having the age of 100-150 are Lahore Passengers Station now Lahore Railway Station (150 years), Punjab University, The Lahore Government College presently Government College University, Central Model School, Veterinary college, Mayo School of Art presently National College of Arts, Convent of Jesus and Mary, General Post Office (GPO), Exhibition Building, Lahore Museum, Lahore Cathedral, The Punjab Chief Courts presently Lahore High Court and Victoria Jubilee Town Hall presently Office of Lahore Municipal Corporation. These examples clearly indicate that buildings stock of colonial period in Lahore is mostly from education, health, religious and service buildings. The flexibility to continue the original use with new requirements became possible in these buildings due to their structural system, architectural spaces and external appearance working all together to support the building function. The key factor for longer survival of these buildings is the nature of function for which these were purposely built.

The continuity of original uses to greater extent in Lawrence and Montgomery Halls made the survival of building possible for the last 150 years. In fact the halls were purposely built for durbars, readings, official meetings, social gatherings, cultural evenings, entertainment, theatrical and sports activities. At present time the main use of the buildings as library is in fact the partial continuation of original functions which supports the architectural spaces and structural scheme created long ago and in result of that the building underwent little intervention such as addition of stairs for upper gallery in Montgomery Hall and some rooms with Lawrence Hall (Fig.4).

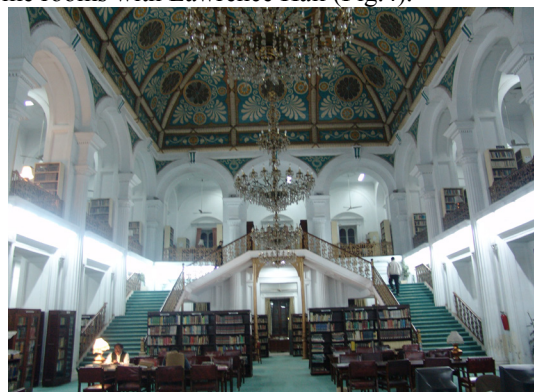


Fig.5. Stair Hall of Montgomery Hall. Photo by Authors in 2010

The building adaptive reuse and external appearance became so acceptable that it brought further extension in the existing use by constructing a large basement hall in the year 2010 with full sympathy to the existing architectural style. The present renovation

of building under taken by the Punjab Archeological department in 2010-11 further proves the architectural significance and worth for adaptive reuses.

#### Conclusion

The continuity of original use of building completely or partially plays vital role to attract the attention of building controlling authorities for maintenance/repair /renovation and hence longer life.

A building can survive for a longer time if it's architectural, structural and external appearance support together to building function.

Many old buildings in Lahore are on their last legs on the reasons that it is not possible to continue the original function. Furthermore the building plans and structure do not permit much flexibility to accommodate new functions. In result of such difficulties and high cost factors the demolishing plans of old buildings are enforced.

The standardization in architectural details during colonial period in Lahore became a useful tool in reconstruction, repair, maintenance and renovation of old buildings. In deciding adaptive reuses for old buildings a careful selection of uses can play a vital role in longer survival. In addition to an effective architectural and structural scheme of buildings the subject of any building has also a major role in longer survival. The flexibility to adjust new requirements is only possible when structural system, architectural scheme and external appearance should support the changes.

#### Acknowledgements:

The Authors are grateful to the office of the Directorate of Research University of Engineering and Technology Lahore-Pakistan.

#### Corresponding Author:

Dr. Sabahat Arif

Department Architectural Engineering & Design  
University of Engg. & Tech., Lahore. Pakistan.

E-mail: [sabahatarif@hotmail.com](mailto:sabahatarif@hotmail.com)

#### References

1. Latif, S. M., "Lahore Its History, Architectural Remains and Antiquities", New Imperial Press, pp.309-311, Lahore, 1892.
2. Buckland, C.E., "Dictionary of Indian Biography", pp. 246-247, London, 1905.
3. Roy G.K., "A Short Account of Lahore Directory 1914", pp 1-2, Lahore, 1914.
4. Kunhya L, "Memorandum on the Lawrence and Montgomery Halls", Professional Papers on Indian Engineering, H. and F.N. Spon and co, pp. 325-326, London, 1877.
5. Abbass C, "*Quaid I Azam Library Ki Amarat , Thzeb and Saqafat Ka Gahwara*" (The Building of Quaid Azam Library: the centre of Civilization and Culture), Mukhzan, Quid Azam Library, pp.144-155, Lahore, 2001.
6. The Illustrated London News, Wood engraving, Lawrence Hall, Lahore, 31 December 1864 and Wood engraving, Montgomery Hall, 17 March 1866
7. Abbass C, "*Quaid - i- Azam Library Ki amarat , Thzeb and Saqafat Ka Gahwara*" [The Building of Quaid Azam Library: the centre of civilization and Culture], Mukhzan , Quid Azam Library, pp.144-155, Lahore, 2001.
8. Abbass C Punjab Government Department Proceeding No. 16, 1878 and proceeding No 40-45, 1906, "*Quaid- i- Azam Library Ki Amarat , Thzeb and Saqafat Ka Gahwara*" (The Building of Quaid Azam Library: the centre of civilization and Culture), Mukhzan , Quid Azam Library, pp.151-152, Lahore, 2001).
9. Vandel P and Vandal S, "the Raj Lahore and Bhai Ram Singh, research and Publication Centre NCA, pp.171- 199 Lahore , 2006.
10. Khan A, Arif S and Rehman A, "Planning and Architectural Solutions in British Colonial Railway Bungalows for Summer Conditions of Lahore", Mehran University Research Journal of Engineering and Technology, Vol. 29, Number-1, pp-25-38, Pakistan, 2010.
11. Kunhya. L, "Tarikh -e - Lahore (History of Lahore), 1884", reprint 1990, Sang- e- Meel Publication pp.357-58, Lahore, 1884.
12. Medley J.G., "Peculiarities of Indian Engineering", Professional Papers on Indian Engineering, Vol.1., pp.397-405, Smith Elder and Co, London, 1863-64.
13. Kunhya L., "Calculations of Strength of Trusses for Re-roofing of Montgomery Hall", Professional Papers on Indian Engineering, H. and F.N. Spon and co, pp. 121-124, London, 1877.
14. Middlemiss C. S, "Memoirs of the the Geological Survey of India", Volume XXXVII, Calcutta, Government of India, pp. 137, India, 1910.

9/6/2012

## Evaluation of the impact of hospitality on tourism development with emphasis on Iran

Sima Hemmati

[hemmatisimal@ymail.com](mailto:hemmatisimal@ymail.com)

**Abstract:** The issue of accommodation in tourism destinations is so important that it has been considered in the definition of tourist, as tourist is someone who accommodates at least one night in a place outside his/her usual environment. The importance of this issue will be doubled when we know that successful tourism destinations are those that have the ability to welcome more tourists with longer overnight stay. The existing state of hospitality in Iran and its impact on tourism development were evaluated in the present study using the research method of descriptive-survey. The results show that hospitality industry requires some major factors for growth and prosperity. Facilities required for investment in this sector and the presence of passengers and customers are two major factors. Without tourists, there is no point in continuation of hospitality industry and generally tourism industry. After the Islamic Revolution, hospitality industry was forgotten and didn't consider as an essential industry in the economic structure of the country, but it was regarded as a luxury good. Little attention to tourism sector caused the hospitality industry to face recession. Despite the increase in the total number of accommodation facilities in the country, this increase was insufficient and there were many problems and shortcomings in the management of hotels, especially the high-grade ones. Additionally, the lack of adequate support of relevant organizations put this industry in an impasse. On the other hand, although there are thousands of beds and tourism resorts in the country, only half of the capacity of these hotels and residences is occupied by passengers at the peak time of journeys. This due to the price of hotels which is unaffordable to many people and middle class or poor people prefer to spend less money for accommodation. Hence, domestic tourists are less interested in staying in hotels, motels, suites, and so on, while the number of foreign tourists entering the country has faced with a negative growth over the past few years.

[Sima Hemmati. **Evaluation of the impact of hospitality on tourism development with emphasis on Iran.** *Life Sci J* 2012;9(3):2660-2666] (ISSN:1097-8135). <http://www.lifesciencesite.com>. 387

**Keywords:** Tourism; Accommodation; Hospitality; Iran

### 1. Introduction

In the new millennium, people's willingness to spend their extra time, especially leisure and free time from work has increased. Some commentators believe that leisure time is time that people use it for themselves and their families. Such incentive makes the international concept of tourism as a tool for the use of leisure time to visit various places and destinations (Herbert, D. (2001)). On the other hand, the issue of accommodation in tourism destinations is so important that it has been considered in the definition of tourist, as tourist is someone who accommodates at least one night in a place outside his/her usual environment (Vanegas Sr, M., & Croes, R.R. (2003) . The importance of this issue will be doubled when we know that successful tourism destinations are those that have the ability to welcome more tourists with longer overnight stay.

#### 1.1. Statement of problem:

The main components of tourism industry, in terms of supply, are divided into 5 sections including attractions, accommodation facilities, transport, travel organizers, and destination organizations. With the exclusion of one-day visitors from other types of tourists, it can be said that all tourists need to accommodate in tourism destinations. So, accommodation is one of the five main sections of tourism product (Morgan, M. (1996). Also, as

accommodation facilities as one of the most important components of tourism supply has different subsections such as inns, hotels, motels, caravans, time property facilities, hotel apartments, etc, this sector of tourism seems to have a great importance. Selection of destination is also influenced by visitors' perceptions and expectations of accessibility to accommodation facilities (Garrod, B., & Fyall, A. (2000). Hotels, especially the 4-star and 5-star ones in Iran have an annual occupancy level lower than the standards. One of the important reasons for this is the high costs of building and maintaining these hotels. In addition, these hotels have high fixed costs. Seasonality of tourism in our country is another reason for the low occupancy level of these hotels which is due to the lack of planning and marketing programs in the tourism downturn season. Hence, the present study aims to evaluate the status of hospitality in Iran and try to answer to the question that what the role of accommodations is in tourism development and increase in the number of tourists (Parasuraman, A., Zeithaml, V., and Berry, L.L. (1985).

### 2. Material and Methods

Descriptive-survey method was used in the present study and research population included accommodations (hotels, hotel apartments, motels,

inns, suites) of the country. Library collection method was used to collect data and other information needed to analyze the status of hospitality in Iran was obtained through field observations. Given that all components of research population were examined in this study, exploratory data analysis methods were also applied.

**Theoretical foundations of Research:**

**1.2. Types of accommodations:**

There are various types of accommodations that can be classified based on the features of accommodations, market trends, business performance, position, function, etc (Lau, P.M., Khatibi, A.A. and Fie, D.Y.G. (2005)). Pizam and Holcomb proposed another classification of accommodations. They classified accommodations by their type such as business hotels, airport hotels, conference centers, suites, hotel apartments, accommodation hotels, casino hotels, promenades hotels, and bed & breakfasts. They also classified the hotels based on their services such as economical hotels which only have bedrooms and bathrooms, the hotels providing all services, and luxury hotels (Sheela, A.M. (2002).

**Table 1:** Types of accommodations (Page, 2007; 207)

Types of accommodations		Function	
		Business	Leisure
Accommodations with services	Hotel	*	*
	Promenade hotel		*
	Educational facilities	*	*
	Airport hotel	*	*
	Motel	*	*
	Inn	*	*
	Bed & Breakfasts		*
Accommodations without services	Hotel apartment	*	*
	Rural homes		*
	Caravans		*
	Camps		*
	Chalet		*
	Villa		*
	Youth hostel		*

**2.1. Hospitality industry:**

The beginning of the new hospitality industry is indebted to European countries, especially Switzerland. This industry developed in small buildings and a variety of services were offered to customers in these small hotels. Hoteliers mostly belonged to the plutocracy and aristocracy. These centers were not called hotel at first, and the word "Hotel" was firstly used since the 1760s. The word "Hotel" is derived from the word "Hostel" which was used to name these centers at that time in England. In the U.S., these such centers and places were called

"Inn". The word "Inn" in English means Caravan, guest house, lodging house, and even house. In addition to this word, the word "Coffeehouse" was used in similar cases. Real growth and development of this industry in the United States began in 1794 with the opening of City Hotel in New York and this was the first building which offered hospitality-related services (Vijayadurai, J. (2008)). Activities of this center motivated other city to compete in this industry, as many investors became willing to come to this industry and establish new hotels. At this time, the number of hotels gradually increased. But the dramatic and wonderful development and expansion of this industry took place in the 20<sup>th</sup> century. Hospitality faced with a heavy and cold recession in the 1930s, but World War II caused a rapid and startling boom in this industry. Collective works and increased capitals in order to establish a chain of hotels began at that time. Owners of smaller hotels found themselves defeated in competition with big capitalists which was a complication to this industry. This industry developed in different aspects and nations and the owners of international chain hotels could apply expertise, technology, and marketing, while the owners of smaller hotels couldn't use these advantages and had no choice to join chain hotels such as Sheraton, Hilton, Hyatt, Holiday Inn, Ramada, etc.

**Table 2:** Classification of accommodations based on their features and market trends (Sheila, 2002; 4-5)

	Market trends		Features of accommodations
	Residential	Business	
Within the city	- Hotels - Suites - Time property accommodations	- Hotels - Suites - Time property accommodations	- Hotels - Motels - Suites - Lodging houses on the roads - Inns - Homes for rent - Bed & Breakfasts - Promenades - Time property accommodations
Outside the city		- Hotels - Motels - Suites - Lodging houses on the roads - Inns - Homes for rent - Bed & Breakfasts - Hostels - Promenades - Time property accommodations	
Airport		- Hotels - Motels - Suites - Lodging houses on the roads - Time property accommodations	
Highway		- Motels - Suites - Lodging houses on the roads - Inns - Homes for rent - Bed & Breakfasts - Hostels - Promenades	

The development of this industry in Europe, the emergence of railroads and mass communication, business development, and the appearance of a new social class (Bourgeois) all were the reasons for the emergence of this new form of hotels. Grand hotels can be considered as the manifestation of the magnificence of all these new social values. At this time, although large families, noblesse, princes, and rulers were still respected, the main objective was to attract the new urban class to the new architecture environment who had vast financial resources. Quality and quantity of respect in the Grand Hotels was based on the capital and bank credit of persons.

### 3.1. Iran's official accommodations:

Under the existing rules and regulations in Iran, official accommodations include inns, hotels, hotel apartments, guest houses, lodgings houses, pilgrim's houses, pensions, youth residence, tourism camps, and tourism and recreation complexes (Administrative law of establishment, modification, completion, grading, pricing, and monitoring the activities of tourism facilities; 1989).

### 4.1. Iran tourism potentials:

Iran is geographically located in the center of a region that has connected Asia, Middle East, and Europe as bridge since the ancient times to the present. One of the most important old routes which passed through Iran was the Silk Road with a length of 8000 km which connected Istanbul in Turkey to Xian in China. This road passed northeast of Iran through Herat, Mashhad, and Rey and went to Iraq and Turkey through Tabriz or Hamadan. The important strategic and geopolitical position of Iran means that Iran has been one of the power centers in the region since the ancient times. This has caused cultural groups in the region to be attracted to Iran make it a center of science, art, literature, and architectural masterpieces. These factors led to the emergence of a rich, unique, tangible, and intangible cultural heritage in Iran. Iran's cultural heritage has been accompanied with exquisite sceneries and climate variations which form comprise its natural geography. These cases include the shores of the Caspian Sea and the Persian Gulf, two great deserts in central plateau of Iran, three major mountains, and western areas of Iran's plateau bordering Iraq. Currently, these natural sceneries and resources are favorite promenades of domestic tourists and also is a market for ecotourists, but they have not been widely used by foreign tourists. Generally, Iran has a rich and diverse natural and cultural heritage and many of its resources that are unmatched in the world

comprise the basis of tourism resources and attractions of Iran.

## 3. Results

### 1.3. The status of hospitality in Iran:

Accommodation facilities are one of the effective constituent components of tourism activities. This includes a set of services, facilities, and installations which determine the scope and function of tourists and provide conditions based on tourists can experience a better relaxation and comfort. Accommodation facilities are divided into formal and informal ones. Formal accommodations have two subsets; accommodations of the first subset have been constructed only for the use of travelers and tourists and include hotels, hotel apartments, lodging houses, and pilgrim houses and the second subset are accommodations that have been established by governmental and non-governmental organizations to provide a suitable accommodation condition for their employees and guests and are not affiliated to Cultural Heritage, Handicrafts, and Tourism Organization.

### 2.3. Hotels:

According to the existing classification system of Cultural Heritage, Handicrafts, and Tourism Organization, hotels are divided into five grades, from 1-star which provide basic services and facilities to 5-star offering luxury services to customers. The number of hotels in the country, according to their grade, is shown in Table 3.

**Table 3:** The number of hotels in Iran according to their grade (Cultural Heritage, Handicrafts, and Tourism Organization, 2011)

Grade	Number	Percentage
1-star	273	31.82
2-star	312	36.36
3-star	172	20.05
4-star	68	7.93
5-star	17	1.98
Unknown	16	1.86
Total	858	100

### 3.3. Hotel apartments:

According to statistics provided by Cultural Heritage, Handicrafts, and Tourism Organization, there are a total of 440 hotel apartments in the country. Reviewing the grading of these units (Table 4) indicates that most of hotel apartments are 1-star (82.05%). 2-star and 3-star hotel apartments make up 13.18% and 3.41% of all such units, respectively.

**Table 4:** The number of hotel apartments in Iran, according to the grading of 2011

Type	Number	Percentage
1-star	361	82.05
2-star	58	13.18
3-star	15	3.41
Unknown	6	1.36
Total	440	100

**4.3. Inns:**

According to statistics provided by Cultural Heritage, Handicrafts, and Tourism Organization, there are a total of 1396 inns in the country. As shown in Table 5, 39.11% of inns are 1-star. 3-star and 2-star inns make up 30.11% and 28.80% of all such units, respectively.

**Table 5:** The number of hotel apartments in Iran, according to the grading of 2011

Type	Number	Percentage
1-star	546	39.11
2-star	402	28.80
3-star	426	30.52
Superior	17	1.22
Unknown	5	0.36
Total	1396	100

**5.3. The status of public accommodations of Iran:**

According to statistics published by the Statistical Center of Iran (Table 6), there were 4662 and 6062 public accommodations in the country in 1994 and 2002, respectively. The highest number of these accommodations in these two years belonged to student complexes and dormitories affiliated to educational centers comprising 48.88% and 46.17% of total, while formal accommodations (Hotels, motels, and inns) made up only 13.94% and 15.19% of all accommodations.

**Table 6:** The number of formal accommodations in 1994 and 2002

Type	1994		2002	
	Number	Percentage	Number	Percentage
Hotels, motels, and inns	650	13.94	921	15.19
Lodging houses, pilgrim house, camp, beach, pension	2279	48.88	2799	46.17
student complexes and dormitories affiliated to educational centers	1137	24.39	1730	28.54
Hostels and camps affiliated to organizations, agencies, and corporations	550	11.80	606	10.00
Other temporary accommodations	46	0.99	6	0.10
<b>Total</b>	<b>4662</b>	<b>100</b>	<b>6062</b>	<b>100</b>

Reference: Statistical Center of Iran, General Census of Industry and Mine- first part, 1999; General Census of Workshops, 2003

Review of the distribution of public accommodations of the country (Table 7) shows that

Khorasan Province with 1029 accommodation units and Tehran with 705 units had the highest number of public accommodations in Iran in 1994. Despite the division of Khorasan into three provinces including Khorasan Razavi, North Khorasan, and South Khorasan, Khorasan Razavi with 2020 accommodation units had the highest number in 2002. Although Tehran Province had maintained its second rank in 2002, the number of accommodation units in this province had decreased to 409.

**Table 7:** The number of public accommodations in urban and rural areas in 1999

Province	Urban areas	Rural areas	Total	Province	Urban areas	Rural areas	Total
East Azerbaijan	189	24	213	Fars	299	6	305
West Azerbaijan	157	30	187	Kurdistan	82	13	95
Ardabil	173	5	178	Kerman	143	23	166
Isfahan	166	16	182	Kermanshah	77	9	86
Ilam	37	4	41	Kuhgiluyeh and Boyer-Ahmad	56	8	64
Bushehr	63	6	69	Guilan	113	23	136
Tehran	646	59	705	Lorestan	64	2	66
Chaharmahal and Bakhtiari	41	1	42	Mazandaran	123	94	217
Khorasan	930	99	1029	Markazi	61	41	102
Khuzestan	241	28	269	Hormozgan	62	9	71
Zanjan	55	18	73	Hamadan	70	6	76
Semnan	39	5	44	Yazd	60	4	64
Sistan and Baluchistan	159	23	182				
<b>Total</b>	<b>Urban areas = 4106</b>			<b>Rural areas = 556</b>			

Reference: Statistical Center of Iran, General Census of Industry and Mine- first part, 1994

**Table 8:** The number of public accommodations in urban and rural areas in 2002

Province	Urban areas	Rural areas	Total	Province	Urban areas	Rural areas	Total
East Azerbaijan	202	27	229	Fars	380	27	407
West Azerbaijan	155	23	178	Qazvin	54	15	69
Ardabil	200	44	244	Qom	109	4	113
Isfahan	212	24	236	Kurdistan	89	35	124
Ilam	47	13	60	Kerman	184	22	206
Bushehr	65	29	94	Kermanshah	103	4	107
Tehran	464	27	491	Kuhgiluyeh and Boyer-Ahmad	49	2	51
Chaharmahal and Bakhtiari	29	3	32	Golestan	54	10	64
South Khorasan	64	31	95	Guilan	172	68	240
Khorasan Razavi	1338	61	1399	Lorestan	90	20	110
North Khorasan	32	5	37	Mazandaran	200	149	349
Khuzestan	258	27	285	Markazi	78	14	92
Zanjan	94	17	111	Hormozgan	194	15	209
Semnan	72	8	80	Hamadan	84	12	96
Sistan and Baluchistan	143	31	174	Yazd	65	15	80
<b>Total</b>	<b>Urban areas = 5280</b>			<b>Rural areas = 782</b>			

**Table 8:** The number of public accommodations in urban and rural areas in 2002

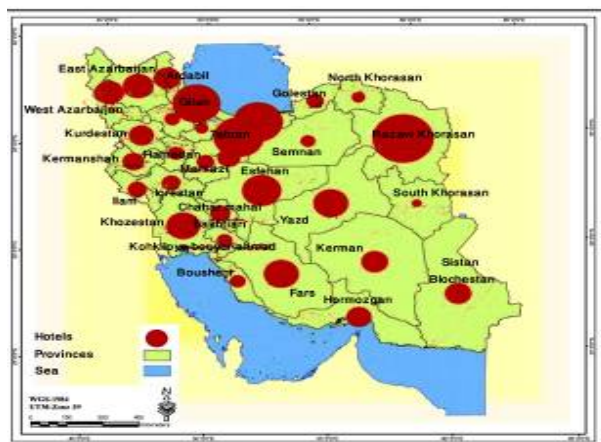
Province	Urban areas	Rural areas	Total	Province	Urban areas	Rural areas	Total
East Azerbaijan	202	27	229	Fars	380	27	407
West Azerbaijan	155	23	178	Qazvin	54	15	69
Ardabil	200	44	244	Qom	109	4	113
Isfahan	212	24	236	Kurdistan	89	35	124
Ilam	47	13	60	Kerman	184	22	206
Bushehr	65	29	94	Kermanshah	103	4	107
Tehran	464	27	491	Kuhgiluyeh and Boyer-Ahmad	49	2	51
Chaharmahal and Bakhtiari	29	3	32	Golestan	54	10	64
South Khorasan	64	31	95	Guilan	172	68	240
Khorasan Razavi	1338	61	1399	Lorestan	90	20	110
North Khorasan	32	5	37	Mazandaran	200	149	349
Khuzestan	258	27	285	Markazi	78	14	92
Zanjan	94	17	111	Hormozgan	194	15	209
Semnan	72	8	80	Hamadan	84	12	96
Sistan and Baluchistan	143	31	174	Yazd	65	15	80
<b>Total</b>	<b>Urban areas = 5280</b>			<b>Rural areas = 782</b>			

Reference: Statistical Center of Iran, General Census of Workshops, 2002

**6.3. Distribution of formal accommodations in the country:**

**1.6.3. Hotels:**

Distribution of hotels in the country (Figure 1) shows that the highest numbers of hotels are in Khorasan Razavi (125), Tehran (88), Mazandaran (82), and Guilan (77). On the other hand, the lowest number of hotels is in South Khorasan (3), North Khorasan (6), Qazvin (6), and Semnan (7).



**Fig 1:** The number and distribution of Iran's hotels in 2011

**2.6.3. Hotel apartments:**

Distribution of hotel apartments in the country (Table 9 and Figure 2) shows that Khorasan Razavi has the highest number of hotel apartments (269). There is no hotel apartment in 12 provinces and there is only one in Chaharmahal and Bakhtiari, Kermanshah, and Lorestan. Also, Khorasan Razavi has the highest number of 1-star (242), 2-star (22), and 3-star (5) hotel apartments in the country.

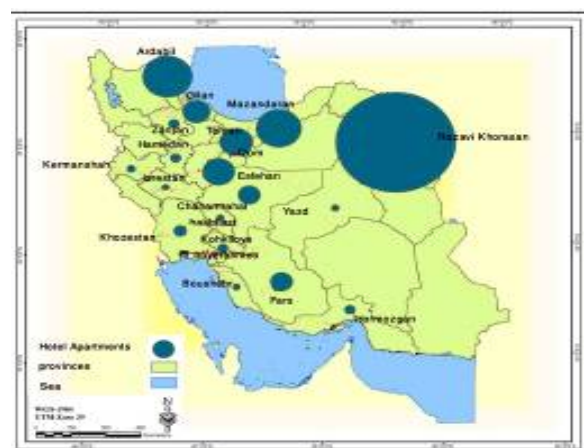
**3.6.3. Inns:**

Distribution of inns in the country (Figure 3) indicates that Khorasan Razavi has the highest number of inns with 451 units. The lowest number of inns is seen in Chaharmahal and Bakhtiari, Ilam, Markazi, and Semnan with 6, 7, 7, and 9 units.

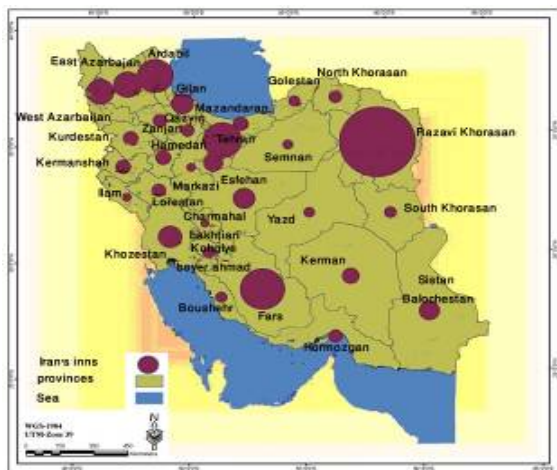
**Table 9:** Distribution of hotel apartments (according to their grade) in provinces of Iran in 2011

Province	1-star	2-star	3-star	No rating	Total	Province	1-star	2-star	3-star	No rating	Total
Ardabil	35	10	1	0	46	Qom	8	8	2	1	19
Isfahan	7	2	0	0	9	Kermanshah	0	0	1	0	1
Bushehr	1	0	0	0	1	Kuhgiluyeh and Boyer-Ahmad	2	0	0	0	2
Tehran	15	3	2	0	20	Guilan	10	4	0	0	14
Chaharmahal and Bakhtiari	1	0	0	0	1	Lorestan	0	0	1	0	1
Khorasan Razavi	242	22	0	5	269	Mazandaran	28	7	3	0	38
Khuzestan	2	0	1	0	3	Hormozgan	0	2	0	0	2
Zanjan	2	0	0	0	2	Hamadan	0	0	2	0	2
Fars	7	0	2	0	9	Yazd	1	0	0	0	1
<b>Total</b>	<b>1-star=361</b>		<b>2-star=58</b>		<b>3-star=15</b>		<b>No rating=6</b>				

Reference: Cultural Heritage, Handicrafts, and Tourism Organization, 2011



**Fig 2:** The number and distribution of Iran's hotel apartments in 2011



**Fig. 3:** The number and distribution of Iran's inns in 2011

### 7.3. Economic analysis of formal accommodations of Iran:

According to figures released by the Statistical Center of Iran, a total of 1,683,592 Rials has been received by public accommodations in 2006. 1617453 Rials has been received for the rental of rooms and beds which accounts for 96.07% of money received by these accommodations. Among the hotels of the country, the hotels of Khorasan Razavi, Tehran, and Hormozgan have the highest money received with 470600, 419328, and 153578 million Rials, respectively. On the other hand, the hotels of Kuhgiluyeh and Boyer-Ahmad, North Khorasan, and Chaharmahal and Bakhtiari have the lowest money received with 899, 1270, and 1466 million Rials, respectively. In the same year, the payment of hotels was reported 957725 million Rials that 49.62% (475180 million Rials) of it was paid as the remuneration of employees. Like the money received, the hotels of Khorasan Razavi, Tehran, and Hormozgan have the highest payment with 253936, 188921, and 111600 million Rials, respectively. On the other hand, the hotels of Kuhgiluyeh and Boyer-Ahmad, North Khorasan, and Chaharmahal and Bakhtiari have the lowest payment with 422, 568, and 2030 Rials, respectively.

### 4. Discussions

Hospitality industry requires some major factors for growth and prosperity. Facilities required for investment in this sector and the presence of passengers and customers are two major factors. Without tourists, there is no point in continuation of hospitality industry and generally tourism industry. After the Islamic Revolution, hospitality industry was forgotten and didn't consider as an essential industry in the economic structure of the country, but it was

regarded as a luxury good. Little attention to tourism sector caused the hospitality industry to face recession. Despite the increase in the total number of accommodation facilities in the country, this increase was insufficient and there were many problems and shortcomings in the management of hotels, especially the high-grade ones. Additionally, the lack of adequate support of relevant organizations put this industry in an impasse. On the other hand, although there are thousands of beds and tourism resorts in the country, only half of the capacity of these hotels and residences is occupied by passengers at the peak time of journeys. This due to the price of hotels which is unaffordable to many people and middle class or poor people prefer to spend less money for accommodation. Hence, domestic tourists are less interested in staying in hotels, motels, suites, and so on, while the number of foreign tourists entering the country has faced with a negative growth over the past few years. On the other hand, the necessity of a long-term relationship with customer's id felt in hospitality industry of Iran. In fact, problems this industry is dealing with are due to the attitude of hoteliers to the industry they are working in. Some of the hoteliers support the view of customer-orientation and some back the view of product-orientation. This means that some hoteliers believe that they should produce a product and then find customer for their product, while the supporters of customer-orientation believe that customer's tastes should be initially identified and then a product in accordance with the needs of customer should be produced in order to attract customers.

### 1.4. Proposed recommendations:

- Tourism industry highly depends on the political, economic, social, and security conditions of each country and quickly become affected by these factors. Security and political stability in the country cause the increasing growth of tourism industry and thereby hospitality industry.
- Providing facilities for the entry of foreign tourists to the country itself can lead to the boom of tourism in the country.
- Legal support for hospitality is one of the requirements to motivate investors. Facilities and loans with low and reasonable interest can encourage the country in competition with other countries in attracting investors. Tax breaks and elimination of other taxes can be effective in this regard.
- Information is not converted to knowledge in Iran's hospitality industry. Hotels should analyze the information obtained from customers and apply the results as usable knowledge in the policies of hotel.
- Iranian website has poor facilities. Lack of possibility to pay online, weak databases, lack of



interactive features to establish long-term relationships with customers, especially permanent customers, lack of specific features such as customer records, and lack of using feedback systems such as conducting online poll on the website, etc are some of the weaknesses of hotels that should be taken into account.

- Training of managers and staff of hotels to improve long-term relationship with customers. The staffs of hotel have the highest interaction with customers and their behaviors have the highest sustainability in the mind of customers after the physical features of the hotel.

#### **Acknowledgements:**

Author is grateful to the persons for support to carry out this work.

#### **Corresponding Author:**

Sima Hemmati

Email: [hemmatisimal@gmail.com](mailto:hemmatisimal@gmail.com)

#### **References**

1. , B., & Fyall, A. (2000). Managing heritage tourism. *Annals of Tourism Research*, 27(3), 682–708.
2. Herbert, D. (2001). Literary places, tourism and the heritage experience. *Annals of Tourism Research*, 28(2), 312–333.
3. Lau, P.M., Khatibi, A.A. and Fie, D.Y.G. (2005). Service quality: a Study of the luxury hotels in Malaysia. *Journal of American Academy of Business*, 7 (2), 46-55.
4. Morgan, M. (1996). *Marketing for Leisure and Tourism*. New York: Prentice Hall.
5. Brown J. Mammals on mountainsides: elevational patterns of diversity. *Global Ecology and Biogeography* 2001;10(1):101-9.
6. Parasuraman, A., Zeithaml, V., and Berry, L.L. (1985). A conceptual model of service quality and its implications for future research. *Journal of Marketing*, 49 (4), 41–51.
7. Sheela, A.M. (2002), *Economics of Hotel Management*, 2002, New Age International (P) Ltd., Publishers.p4-5.
8. Vanegas Sr, M., & Croes, R.R. (2003). Growth, development and tourism in a small economy:Evidence from Aruba. *International Journal of Tourism Research*, 5(5), 315–330.
9. Vijayadurai, J. (2008). Service quality, customer satisfaction and behavioral intention in hotel industry. *Journal of Marketing and Communication*, 3 (3), 14-26.
10. Yoon, Y., Chen, S., & Gursoy, D. (1999). An investigation of the relationship between tourism impacts and host communities characteristics. *Anatolia: An International Journal of Tourism and Hospitality Research*, 10(1), 29–44.

9/17/2012

## Comparing the role of the middle class in political development (democracy) of Turkey and Saudi Arabia

Abbas kaabi

Department of Politic, Tajikistan Academy of Sciences

[KaabbiA2@gmail.com](mailto:KaabbiA2@gmail.com)

**Abstract:** The term of Middle class is one of the common terminology in humanities especially, sociology and political science. Although it is not long time since the composition have emerged in books, articles and academic circles, very sensitive and important role of this class in society transformation has caused researchers and politicians pay particular attention to it. So there is three classes in society, the classes who possess accumulated capital, the low class who are in challenge to satisfy their necessary needs and finally the middle class who earn their living without trouble but not involve in accumulating great capital. Thus, in democracy progression, it can be said that because of their special position, middle class use third class emotion as a pressure factor and upper class wisdom as a prudent or reconcilable factor. So in the paper, we try to examine the middle class role in the process of political development and more detailed explaining of political power and democracy establishment as a method that paves the way for people more collaboration in governance, particularly in two countries of Saudi Arabia with a traditional and hereditary and Turkey with relatively democratic structure.

[Abbas kaabi. **Comparing the role of the middle class in political development (democracy) of Turkey and Saudi Arabia.** *Life Sci J* 2012;9(3):2667-2674] (ISSN:1097-8135). <http://www.lifesciencesite.com>. 388

**Keywords:** class, political development, democracy, Saudi Arabia, Turkey

### 1. Introduction

The relationship between political power and social classes is very complex and better understanding of society political life enjoys special places; political power can be divided into social and governmental power, accordingly in order to examine transformation in political layer, changes in social power and the manner of its transforming into political power which is as a main political power basis among middle class must be addressed (Haggard Stephan and Robert R. Kaufman, 1992). Class analysis is one of the theoretical approaches in the study of politics and society. In the beginning, classification (layering) was used by scholars and statesmen to determine patterns of political struggle and social transformation. In fact, one ways that lead us to understand the social structure is analyzing the layout and class structure in society. In the context of social class layout, most of the scientists have divided social groups into three categories: upper class, middle class, lower class, among these middle class will be compartmentalized old and new middle class. Upper class can be included royal family, nobilities, military and economic elite, capitalists and senior scientists. Middle-class consists of bureaucrats, professionals, petty bourgeoisie, merchants and ... And lower-class comprises workers, the unemployed, farmers and nomads.... The emergence of the middle class in various social and political arenas is so important that most of the thinkers know it as an underlying in forming new societies and one of the fundamental prerequisite elements in democratic

society. Thus, relatives to the middle-class are recognized as democracy pioneers and economic, political and social development leaders in communities (Mackey, Sandra (1996).

#### 1.1. Significance of middle class in political development (democracy)

Larok argues that middle class consists of several groups, all of them have common feature namely they are not involved nor in worker neither in ruling class (Gelvin, James L. (2008) Shakirva has written: Middle class is part of society which is placed between the upper and lower classes and characterized by high level of union, income, proprietorship, intellectuality, talent and significant skill in work (Daniel Bertaux, & Thomson, Paul.1997). In Most theories about class, the evident aspect on middle class is its critical role in the advanced new capital development. Middle class member are known by three outstanding features: education, advanced technological and executive skills and significant autonomy in working process (Moore Barrington.1966). Apart from this, they are beneficial actor in social procedures with powerful motivation to joint to new social movement (Wright, Erik Olin.1997). New middle class plays a central role in transforming social-democrat and above them worker unity organization. In Most theories about class, the evident aspect of new middle class is its critical role in the advanced capitalism development. Middle class members are known by three outstanding features: education, advanced technological and executive skills and significant

autonomy in working process, apart from this, they are beneficial actors in social procedures with powerful motivation to joint to new social movement. New middle class plays a central role in transformations social-democrat and above them in labor union organization. The upper class possess concentrated capital and lower class deals with challenges in satisfying their essential needs, middle class is referred to the groups that subsist ordinarily without trouble and not involve into accumulating great capital. If all definition is acceptable without exception, it seems the middle class have greater impact of social-political transformation: Because the upper class usually knows social order as a preserver for its position which is desirable and since plunging in accumulating wealth and power to exploit it most of the time does not allow it to think about reformation, it is natural for the upper class not to follow social structure transformation and even protest against it. Despite the lower class is likely the most beneficiary from this reformation, it is relatively deprived from achieving to reformist theoretical and practical freeness because of immersion into supplying its minimum demands. But the middle class inevitably deals with reformation thinking and necessities because in one hand it is not under the pressure of supplying the necessities and concern for satisfying his stomach due to his relative richness and is not fully hired by economy and cannot concentrate and accumulate unlimited wealth due to its relative poverty, on the other hand also because of his cultural and administrative jobs which is concentrated in this class(Grant, J. Andrew (2001)). Therefore, the most primitive societies have been detectable in the absolute absence of middle class. So that it is not wrong if we say the history of new culture and civilization is a history for emerging and expanding the middle class. The new class thinks to invent an instrument to be as a castle toward this devastating attack in order to preserve itself against arbitrary and occasionally libertine actions of upper class which primarily characterized by concentrating power or wealth and predominated on the political governance. So that democracy with separation principle, or in louder word, powers division, representative system and ruling the law documented by majority votes and preserving the minority right was founded by middle class. Middle class involving in democracy will not last here, but the class ensures the most competent elements for establishing democratic system due to its own specifications and above mentioned reasons the upstream and downstream are contradictorily have less share in thought in public sense and reform thought in special sense. So because of it not only the selected representatives, executive, justice force agents and

senior officials but also aware and selector voters, of course not the voters who comes to ballot box in weak or incomplete democracy or those who vote for promises and threat or influenced by other one without sufficient ware and consciousness, are belonged to middle class. On this basis, we can accept that developing middle class is a laying plot for political development and its restriction encourage power accumulation and political power concentration, by eliminating middle class in society, the lower class with two descriptions of relative deprivation from scientific education and being troubled in economic struggle for exist will be defenseless against upper class with two public descriptions of power and wealth concentration. Denial of education make the lower class's culture static, weak, introverted and unable and weaken its survival of noneconomic sensitiveness. So that, If the top class does not incline to monopolize political sovereignty, basically there will be no option except this; because power sharing needs the middle class whose scientific education and economic freeness allow it to think and select. If the classes will be authorized to share the upper class' wealth or power, the third class is willing to share the wealth, while the middle class prefers the power to be shared. In other word, the middle class valorize the freedom originally meanwhile knows it as a mediator to achieve economic balance, while the weak class is more prepared to grant its political right instead of ensuring their economic necessities. A third category is sensitive to the concentration of wealth in the first class and middle class is sensitive to the concentration of power in this class. So for the reason the middle class is principally and habitually want to peaceful reformation of political structure and if it fails in achieving the goal, it has to stimulate and encourage third class toward a social revolution whose main motive is to change the manner of wealth sharing and if changing political structure is desired, it will be along to this goal. This is why the lower layers tend to socialism and top layers more incline to liberalism. Both of them seek justice, but one sees justice in the sharing wealth and other knows it in sharing power. One persists on the threat associates with not distributing the wealth properly and the other focus on disadvantages of not proper distributing of power. An important point is that both transformations are inevitably done by middle class, with differences that in one of them it is necessary to stimulate the lower class and bring them into the scene and to release their great potentials and in the other it is not true. Either way, the original intentions of the middle class is political reformation and in turn social and legal reform, and ultimately, the economic

and cultural development and progress (Mahony, Pat & Zmroczek, Christine.1997).

### **2.1. History of social classes and Democracy in Turkey**

Despite the constructing of landholding in Turkey was in the a major part of Ottoman Empire era based on the independent landowners and without large landowners, but by integrating in the world system from the beginning to the end of the nineteenth century, the rich landlords emerged in some parts of the country though they are never more powerful than Iranian landowners and predominant to farmers. Although Ottoman society was based on farming, handcrafting, ranching and trade until the nineteenth century, its ethnic labor division was different from the identical communities. Balkan Christians, Anatolian Turks and Arab Muslims were sedentary farmers. Albanians, Kurds, Turkmen and Arabs were nomadic ranching; Greeks, Armenians and Christian Arabs who were mostly Lebanese residents were trading as well handcrafting was common in Istanbul and in the control of Muslims. Ottoman reformation was conducted in king Selim, Mahmoud II, and Abdulhamid era could not create a basis for a powerful Turk bourgeoisie and integrating in the world system and strong competition with international powers weakened the power of the bourgeoisie which was concentrated in the hands of ethnic minorities. The young Turks revolution in 1900s and duration of their governance till 1916 was a kind of attempt to create Turk bourgeoisie but by defeating the empire in First World War and occupying the Ottoman by winners the vision of Bourgeoisie was never realized. Thus, the Ottoman Empire at the end of the nineteenth century with a strong commercial and industrial bourgeoisie was weak class that was focused on ethnic minorities. Although Young Turk Revolution of the 1900s and its duration until 1918 was a kind of attempt to create national Turk bourgeoisie, by failure of Ottoman Empire in World War I and its occupation by victorious powers, the Turks bourgeoisie dream was not realized. More importantly, at the late of 19th century and in the process of interchanging the ethnic groups between Turkey and Greek, a kind of ethnic cleansing was done in Turkey and suddenly the country was evacuated of the minorities who shaped the main body of commercial and industrial bourgeoisie. Workpeople 's weakness was resulted from the Turkish industrial bourgeoisie because of which there was no space for workers' production. Thus, when Atatürk won the Turkish Independence War, only had landowners' force was formed in the middle of the nineteenth century and a very weak bourgeoisie. As tariff trade rules was being established in Iran till 1928, the rules were existed in

Turkey until 1929. From this year onwards, Kemal government by ridding from tariff trade achieved more freedom in economic interventions. The critical condition of world system in this year and the years afterward had weakened the landholders who were dependant to exporting farming materials, so that Kemal government found the only faced powerful class force weakened. Atatürk applied statism policy and governmental centered planning and state interventions to industrializing because of lacking national bourgeoisie for proceeding modernization planning and landholders' weakness to prohibiting state actions. And simultaneously spread his own party authoritarianism sovereignty- Republican People's Party. The number of workers in Atatürk era (1920s and 1930s) was not enough to be able to withstand against the Atatürk government. According to the coalitions of army forces, bureaucrats and landowners at the beginning of the Republic, and the lack of industrial development that can promote labor force, it was natural that the workers had no power to have organized participate in politics. While the Kemalist thought that by removing Ottoman Sultan, and foreign capital, class conflict between Turkish societies would be omitted and other class organizations would not be needed at all. Atatürk era policy and their continuances during the presidency of Ismat İnönü made severely the landowner, private sector and workers dissatisfied. A class of state bureaucrats, mainly belonging to the People's Republican Party took the affairs administration and presumed no force against them. But World War II changed the situation completely. Economic crisis resulting from the war had two evident effects. First, a group of big businessmen in war inflationary conditions gained a great wealth. In wartime demands for producing Turkey goods will increase and the price of imported goods in inflationary conditions were very profitable. Therefore, the layer of commercial bourgeoisie but powerful arose in Turkey and demanded a greater share in economic policy-making and political power. Secondly, the government attempts to transferring villagers for forced labor in mines and most importantly the "capital tax" to raise the funds for the war. The law was passed on 11 November 1942, it was decided that the tax be laid on for the wealth derived from trade and was tax-free in the past. Their capital was also assessed by the experts. Those who pay no taxes were taken to concentration camps. Most of the business tax receipt from merchandises among religious and ethnic minorities and most of the traders who were overtaxed were eliminated. Many foreigners thought this tax is a kind of opposition and this effort encouraged the fleeing of the capital and the other hand the weakened the non-Muslim

bourgeoisie. As a result of enforcing the law, a climate of mistrust was shaped toward Turkish state and economy. After the end of the war, the World system was changed completely. Turkey took the shelter of west for sake of Soviet territorial claims and became a member of NATO in 1952. Americans also tried to reconstruct Europe and needed Turkey as a food crops producer to supply Europe and European product markets. Various pressures powered by the new bourgeoisie, the landowners who export agricultural crops and U.S.A for transiting to multi-party democratic system were on Ismet Inonu's government. Finally, the pressure led to create a multi-party system in 1946 and democratic elections in 1950 (Przeworski, A .1997). Turkish landowners and independent farmers that remembered the years of Ataturk rule, the Republican Party or policies of transferring surplus from agricultural sector to industrial sector-by fixing the governmental purchase price of agricultural products and increasing investment in the industry-in new world system conditions inclined to open markets and increase their share in economic policy-making, are severely supported multi-party democracy and accompaniment with democratic dialogue governed during the after war years. Agricultural modernization program were closely followed during the years 1950 to 1954 reflected place of the same landowners in the state and of course the world system demands. More wonderful that Turkey democrat party in three sequential parliamentary elections during the years of 1950, 1954 and 1957 won by assisting independent farmer's vote and the farmers who are predominated by great landholders as well decreasing the votes in 1957 election referred to people abstain from the party (Barkey Henri J..2010) Turkey industrial bourgeoisie which had been grown under the support and sovereignty of Ataturk era governmental bureaucracy, supported democrats in 1950 election, however the Menderes state did not continue the industrializing policy in the manner of Ataturk statism and as stated the economic policy was based on little bourgeois agriculture. This half-ripe bourgeoisie strictly needs ex-government supports via granting loans, foreign exchange credit, import and export permits. By Issuing Import licenses by state could be benefit about millions of pound for each person and by granting kinds of credit and other support controlled the political action of this class. Turkish agriculture in the early 1950s was boomed due to the good weather, market for Turkish products (because of Europe needs and Korean War) and not saturating the cultivated lands, but become lethargic since the middle of this decade. Thus the government found the currency supply weakened and industry financing was faced with difficulties.

Importing was again controlled and among dissatisfaction raised from commercial bourgeoisie and pervious discontentment of industrial bourgeoisie from democratic state, Menderes backed up farmers to ensure filling his ballot box (Barkey Henri J.2010). All of industrial bourgeoisie, Bureaucratic and economic middle class, and workers in the late 1950s were democratic dissidents and just the farmers and landowners still supported democratic elections. Bourgeoisie, middle class and the labors was sure that Menderes' state relied on a large number of farmers and using paternalistic development policies saturated with economic rents to landowners and independent farmers can defeat any other political process in election ballot and so there was no resistance against the military coup and overthrowing the Adnan Menderes' government in 1960. Even university professors, students and other groups of middle-class who were the major supporters of the Democrats in the 1950 elections became the main force of opposition against the Menderes government in 1960. Bourgeoisie and middle class democracy demander were not in unequal position to landowners and farmers. Landowners, Turkey bourgeoisie and middle class had supported the Adnan Menderes selected democratic state but the economic conditions and world system pressure creates harmony between state diplomacy and landowners or independent farmers' demand, as a result 2 years after Turkey democrat party had won, dissatisfaction of industrial bourgeoisie and middle class started. At this stage, landowners were still associated with democracy and sure about their victory in election ballot box.

### **3.1. Middle-class status in Turkey current situation**

Clearly, there is a relationship between military weakening as consequences of civil society empowering and strengthening the democracy bases in the Turkey (Davutoglu Ahmet.2012). A social-political sphere with just division of income and wealth and active civil society organizations (CSO) and consciousness middle class is the best guarantee for democracy and freedom in a country like Turkey. First, it must be admitted that the reforms of the past decade which was conducted by empowering of the AKP was not the first and mere step in the democratization process in Turkey (Richard Weitz, 2012). It should not be denied that the Justice and Development Party create revolutionary and unprecedented reforms in the country. However, if the economic and social- political infrastructure was not founded at the beginning of the 1980s, the Justice and Development Party, as part of the political superstructure, would not succeed in implementing these enormous reforms. Investigations indicated that the number of civil organization in Turkey was

60931 by 2000 which grew 235% more than 1990. The number increased to 90930 till 2011 that show a 45% grow to 2000. According to statistics, in 2011, nearly 8 million people in Turkey become the members of these organizations. Although these numbers and statistics seem satisfactory, it is not sufficient in comparison to other developed countries. For example, the number of civil society organizations is 2.1 million in Germany and 1.4 million in France. In the United States the number is 7 million. Thus we can say that neither the state nor the political parties can ensure the democracy in country because developing and advancing civil society and consequently middle class growth, through which people can authorize and influence on their own destination, is the best back up and guarantee to realize democracy in a country. Saudi political structure and formation of the middle class

Important features of the Saudi Arabia political system include the authoritarianism, traditional oligarchic and patriarchal, king assignment, conservative sheiks assembly, Saudi family, independent judiciary, a severe limitation for the institution, civil activists, new middle class, the corrupt advocator-follower relationship between government and tribal elders, clerics and traditional merchants, monopolization in governmental key positions in the capital and provinces to Saudi Arabian major princes, Saudi's family economic corruption, Saudi family's perpetuated embezzlement to oil increased revenues, severe government repression, the fierce intelligence and security forces across the country and so on. In Saudi political system, king mainly makes strategic decisions. The executives is responsible only towards the king, of course ministers' accountability to appointive advisory council has been accepted since 2005 onwards, however they should be accountable toward king; cabinet are more consultative role rather than determinative. In practice, there is a kind of force integration rather than force separation and all matters are substantive to the king. The judiciary is independent of the king and Supreme Judicial Council is composed of 12 chief justices, all of which are installed and removed by the king. King possess the crude oil and all economic financial resources and perfectly supervised all governmental and non-governmental institution and offices, absolute control of governmental assets by king make him not to know himself accountable toward publics. Sheikhs House is mere controller of Shah, of course it often has conservative and non-challenging characteristic for political, religious and financial joint. Saudi oligarchic and authoritarianism political system has been faced to this mal-condition by exposing and mobilizing the social and political challenges behalf

of practitioners, thought and political movement belonging to new middle class since the second half of the 1980s. Relatively quantitative and qualitative fast growth in this class and its associated components, perhaps for the first time, has confronted this highly conservative state with a relatively strong opposition for the recent decades. It should be noted that the Gulf War and its afterward political and economic crises was influential on powerfulness and increasing political courage in revealing state political challenges. Saudi government was forced for the first time in this context that to give up to some even limited political reforms. By studying historical changes and classic revolutions in recent century, perhaps we can say that the middle class is the most effective classes. New middle class strongly supported the new social movements like the student protest movement, civil rights, feminist, environmentalists, disarmament, and, during the recent decades. Thus, the political developments and protest and reformist movements either in developed countries or in developing countries without addressing the role of this class will be imperfect. Since establishing the Saudi government in 1932 based on religious and political unity, the government has been the most authoritarians and conservative royal governments Arab Middle East. Saudi political system has been based on political and religious patriarchy since its beginning and has continued to this day. In general, several important factors were involved in Saudi family government include unity and political or religious ties between the House of Saud, Ulema and Wahhabi doctrine, mutual bonds between the clan and tribal leaders, political repression, strengthening civil traditional institutions, such as market, clergy and tribes, preventing a new civil institution empowerment, developing the links of clientelism between the government and its affiliated institution members from private sector, intelligential strong repressive systems and foreign powers support of the clan. In recent decades due to social changes in the fields of education, communication, urbanization, and like that, the new middle class in Saudi society has experienced increased quantitative and qualitative growth. Since the second half of the 1980s, especially from the 1990s onwards, the class confronts the Saudi government with significant challenges and political and social criticism; the challenges on one hand widen the people political and social awareness toward the government, inefficiencies and corruption and on the other hand, have led to some even limited political reforms. Although the members and groups belonged to the class are not integrated in Saudi Arabia they are allied on the necessity of political reform, building democratic institutions, strict

fighting with corruption, independence of judiciary, separation of forces and the like.

#### **4.1. The new middle class and political challenges in Saudi government**

One of the new features of Saudi society is the quantitative expansion of the new middle class which is considered as a product of socioeconomic modernization program since the 1970s afterward. According to a survey, the proportion of the new middle class to population was increased from 2 percent to 11 percent in the late 1980s. The quantitative and qualitative growth (enjoying awareness and thought or attitude transformation) of the class make it to emerge as a most important transforms and reformist social force and increase his political weight over the time by a significant rate. Saudi government since the second half of the 1980s has been faced by the political challenges and serious criticism from new middle class. During the recent decades, civil and political groups and practitioners among this class has been emerged as a most important critic and opposition of Saudi government during their social political life, it can be said the class is the main important source of challenges and imposing political and weakening pressure for political legitimacy of the Saudi royal family. This class is almost significantly able to emit the political and social life of community's from political stagnation and static pressures, and under its pressure the government was forced to do some limited political reforms. The middle class was the source for emerging three new social-political, protest and critical flow in the Saudi society, which include: a) liberalist intellectuals b) Reformist Islamists believed to new interpretations of traditional religions, and c) The Shiite Muslim reformer and critic (Farsy, Fouad.1982, Hopwood, Derek (ed.). 1972).

#### **5.1. The new middle class and the Islamic movement, the origins of reform in Saudi Arabia**

Growing the middle class in Saudi Arabia, although non-integrated and somewhat imbalanced and quantitatively wide was caused the traditional network of government accept the limited political reforms. The spectrum supported Islamic awakening and demanded reorganizing the Saudi kingdom based on Islamic state. The social stream attacked the liberals for their secular desires. However, many weakening preachers after his release from prison in late 1990 abandoned their radical policies, ignore the corruption and violation of citizens' civil and political rights and support the status quo against the social reformist thought. Since the late of 1990, the liberal or new Islamist flow has emerged in middle class, the flow fought and operate in media and political area and was the other source in creating political and legitimacy challenges against the government. Inside

the flow, there are two spectrums of political and social reformist, the member of the flow are mostly high educated. Social reformists are the serious critics of religious and social conservatives and know the social changes more essential than political changes and believe that by lack of fundamental religious social, political changes will lead to disastrous results. From their point of view, the social and political awareness and social changes is preferred to political changes and common religious manners and formats can be removed just by social reconstruction. The political reformists' origin is Islamic vigilance movement. To provide an Islamist progressive theory and design civil society, public participation and democracy within the framework of Islamic law, the group demands significant reconstruction of country social and political life, a constitutional monarchy, electoral institutions, separation of powers, freedom of expression, gender equality and recognizing Shiite rights. In general, all Islamic movements in the past two decades, despite the differences are common and agreed in some important issues: the opposition to Saudi Arabia's dependence on America, oppositions to issues such as social injustices, government officials' corruption, the deviation from true Islam and human rights abuses, the new middle class, despite the tendency toward modern Western democratic values emphasized on political independence in their foreign policy and has targeted the conservative relations between America and Saudi government. The members and groups belonging to the class had targeted the conservative beliefs and traditional and tribal relationships and in contrast support the civil relations and interest and the necessity to expand participative and active citizen, the new educated people do not believe the tradition-tribal legitimacy basis and protest to government authoritarian and supersession, they demand to substitute constitutional monarchy system to authoritarian monarchy, democratic reforms and multi-party system, despite of Saudi state attempts to recruit a significant part of this class in governmental offices, they were critic of Saudi authoritarian and conservative government due to their academic education, political awareness and democratic attitudes and beliefs, dissatisfaction among members of this class against violations of human rights and fundamental freedoms was one of the roots of the political challenges and the legitimacy of Saudi government. Economic corruption is another source of new middle class's objection against the Arabia government. Increased oil revenues in Saudi Arabia, is an important factor in the perpetuation of authoritarian rule.

Saudi state views oil revenues as Saudi royal incomes, the state creates and expands the kind of

advocator-follower clientelism relationship with tribal elders, wahhabi clergies and traditional markets along stabilizing Saudi royal family by using oil revenues. State ensure their political support and back up by distributing oil revenues between them to remain immune from their political challenging. New middle class strongly object to the corrupt relationships and give or takes and know it as a sign of political illness. According to International Transparency record, Saudi Arabia is among those countries with high levels of corruption. Another source of opposition among new middle class is very low levels of political freedom. According to statistical data, the kingdom is already an undemocratic country. In divisions from the valid statistic- research centers the grades 1 - Represents the rule of law and the exemption of political prisoners, the score 2 - Represents democratic and legal rule with the lowest political prisoners, grades 3 - Represents the high number of political prisoners, the score 4 - Represents the torture and killing the Political prisoners and score 5 – Represent the most horrible regimes. Saudi Arabia with the score of 3 is among the countries with high political prisoners.

**Table 1: dividing countries in terms of democracy and non-democracy level**

countries features in terms of score from 1 to 5	Score from 1 to 5
Indicates the rule of law and exceptions of political prisoner	Score 1
Indicates the democratic and legal rule with the lowest political prisoners (Turkey)	Score 2
Indicates the high number of political prisoners (Saudi Arabia)	Score 3
Indicates the torture and political murdering	Score 4
Indicates the most horrible regimes	Score 5

High growth of unemployment and rising military spending were the other source of new middle-class protests against the government of Saudi Arabia. Saudi Arabia since 2005 has faced the challenge of high unemployment level of 15%. According to the "International Research Institute on Peace» Saudi Arabia spent \$ 38 billion in military procurement equivalent to 6/2 percent of the world's shopping, is ninth in the world rankings. Between 8 to 11 percent of gross domestic product is devoted to military procurement which is a very high figure in Saudi Arabia. In 1995, the country's arms imports relative to total imports was 31/3 per cent. The huge increase in military purchases encounters the country with high political and economic challenges and external massive debts, after the Persian Gulf War. According to other statistics, the percentage of state expenditures grow as a result of enhancing in public

spending in Saudi Arabia are: 1980 (7/15), 1984 (34/4), 1988 (34/2) and 1992 (3/32). Internet has been a main channel and source of protest and challenges to data exclusivity in Saudi government since the second half of the 1990s onwards. Although public access to the Internet was started since the end of January 1999, the internet has been used by militants related to the new middle class since before namely from 1994 for political struggle. "Committee for Defense of Legitimate Rights," was the first organization affiliated to the class that used the Internet for political struggle for the first time. In 1996, the chairman of the committee, Sadan faghihe (surgeon) constructed the Committee's website in London and managed it. Although the Saudi regime blocked and filtered the political and pornographic sites, Internet users can access to political information and disclosures via internet through the proxy. However although we can say that during the recent decades, we visited quantitative and qualitative growth of new middle class influenced by structural changes and reconstructive process and the class glowed significantly, due to perennial tribal and traditional context and lack of cooperation between social body and intellectual body, the class did not enjoyed the serious, qualitative and quantitative support of mass thought to fight to government and realizing the reformist demands completely. Additionally, the level of education and political social awareness of the masses are not high and largely obey their tribal elders. So in this context we can say that the social reformist forces were not backed up by public opinion and social body. New middle class could partially create common shared strategies and purposes between the different thought aspects include moderate Shiite and Sunny Islamist and partially the Islamist inclined to liberals, the matter is apparent in their notions and complains. However the evidence shows that they are not completely solid and government creates a gap between them and prohibiting the cohesion among them by responding to more moderate political flow, thus they relatively satisfy the limited reformations. Generally, the affiliated members to the new middle class as activists to some extent could convince Saudi government to be respondent. If they play their role continuously and fulfill above conditions, this class may be an avatar of non-secular democracy and in the future of Saudi society and increase the reformation level.

## 2: Discussion

Democratization or transmission to democracy and role of middle class is one of the important issues that have been paid attention to it from the past and especially after the 11<sup>th</sup> September and great Middle East plan. Today, according to



globalization and multiplicity of interactions among the nations and human societies, the democracy dialogue is in people mind so that can be opposed clearly and even the most dictator countries attribute themselves to democracy and named their government as democrat to prevent internal and external pressures.

Thus in summarization, we should say the ending cold war have two effects of international systems; the first one the free market economy has no rivals and more or less permeated to governments as the best economic system, secondly, end the competition between ideologies and opening international politic system space and political space among the states. The issue expanding **new middle class** in most of the countries during the two decades, as well as provide protesters with a new space to follow their demands free from the bipolar ideological wars. Expanding new middle class after political-social-economic transformation after the years of Cold War, revealing a new slot in the post-Cold War space, government attribute the opposed groups to East or West camps and suppressed the challenging movements severely, increasing the penetrability level in region governments due to formation and expansion of satellite nets and covering political suppression of the states at regional and global level and enhancing the charge of these suppressions especially after establishing Aljazira net, increasing expansion of internet and virtual space in regional countries and overall the growing popularity of democracy and democratization waves after cold war and increasing the Arab powerful sovereign rulers' expenditures led to people protests increase and have an integrated shape in virtual civil society. New middle class due to its especial nature never resort to force and applies the tools of peaceful protests and demonstration such as taking refuge to precede their goals. Starting new changes in Arabic Middle East can be affected by growing new middle class influenced by structural changes in international system after cold war and spreading the globalization. The changes increase the role of non-governmental actors and penetrability in states internal or external sovereignty as well forming cooperation model among the countries influenced by international risks became new and serious. Spreading the globalization speeds up the changes. All the factors cause the area of political-social groups will be opened without the consideration of cold war as well as the economical growth in countries and awareness and literacy in global level intensified the new middle class formation. Growing

of the factor is the main cause of future transformations in 21<sup>st</sup> century which the recent transformation of Arab Middle East region is its advent sight and its perspective cannot be predicted now but it is forecasted to be accelerated in future.

#### **Acknowledgements:**

Author is grateful to the Department of Politic, Tajikistan Academy of Sciences for support to carry out this work.

#### **Corresponding Author:**

Abbas kaabi

Department of Politic, Tajikistan Academy of Sciences

Email: [KaabbiA21@gmail.com](mailto:KaabbiA21@gmail.com)

#### **References**

1. Barkey Henri J.2010, "Turkey's New Global Role," Carnegie Endowment for International Peace, November 17.
2. Daniel Bertaux, & Thomson, Paul.1997. *Pathways to Social Class: A Qualitative Approach to Social Mobility* (Clarendon Press.).
3. Davutoglu Ahmet.2012, "Principles of Turkish Foreign Policy and Regional Political Structuring," International Policy and Leadership Institute and Economic Policy Research Foundation of Turkey (TEPAV), Turkey Policy Brief Series,- Third Edition.
4. Farsy, Fouad.1982. *Saudi Arabia: A Case Study in Development*. London: Kegan Paul International.
5. Gelvin, James L. (2008). *The Modern Middle East Second Edition*. Oxford University Press, Inc.
6. Grant, J. Andrew (2001). "Class, definition of". In Jones, R.J. Barry. *Routledge Encyclopedia of International Political Economy: Entries A-F*. Taylor & Francis. p. 161.
7. Haggard Stephan and Robert R. Kaufman, 1992."Economic Adjustment and the Prospects for Democracy", in Haggard and Kaufman, eds., *The Politics of Economic Adjustment* (Princeton,NJ: Princeton University, 1992), p. 320.
8. Mackey, Sandra (1996). *The Iranians: Persia, Islam and the Soul of a Nation*.
9. Mahony, Pat & Zmroczek, Christine.1997.*Class Matters: 'Working-Class' Women's Perspectives on Social Class* (Taylor & Francis.).
10. Moore Barrington.1966. *Social Origins of Dictatorship and Democracy: Lord and Peasant in the Making of the Modern World* (Boston: Beacon Press.).
11. Przeworski, A., M. Alvarez, J.A. Cheibub and F. Limongi.1997. "What Makes Democracies Endure?"In *Consolidating the Third Wave Democracies: Themes and Perspectives*. L. Diamond et al. (eds.) Baltimore and London: The Johns Hopkins University Press.; 295-312.
12. Richard Weitz, 2012. "China-Turkey Summit: Economic Enticements Overshadow Differences," *Turkey Analyst*, vol. 5, no. 6, March 19.
13. Rowman -Hopwood, Derek (Ed.). 1972. *The Arabian Peninsula: Society and Politics*. Totowa, New Jersey: and Littlefield.
14. Wright, Erik Olin.1997. *Class Counts: Comparative Studies in Class Analysis* (Cambridge University Press.).
15. Whittaker RH. Evolution and measurement of species diversity. *Taxon* 1972; 21:213-51.

9/17/2012

## America and Russia oppositions in middle Asia after eleven September

Mahdi Nouri

Abdanan branch, Islamic Azad University, Abdanan, Iran  
NouriMahdi3@ymail.com

**Abstract:** After union of soviet republics collapsing, dominance in middle Asia was one of main and key American foreign politics purposes. This act was discussed after eleven September incidences and American presence in Afghanistan more than ever. American politics in middle Asia are parallel with main politics of this country in world level and confronts with countries that dominated on region and their politics aren't parallel with American benefits. According to this procedure, America thinks about limiting dominance in middle Asia and exiting this region under Moscow security umbrella. Russia as soviet heir wants to preserve traditional dominance in region and surveys American efforts for dominance on region carefully and tries to neutralize it.

[Mahdi Nouri. **America and Russia oppositions in middle Asia after eleven September.** *Life Sci J* 2012; 9(3):2675-2679] (ISSN:1097-8135). <http://www.lifesciencesite.com>. 389

**Keywords:** Middle Asia, eleven September, America, Russia, foreign politics

### 1. Introduction

Forty years cold war developed pattern of relations between America and soviet that its main characteristics is competition and confront in all of security , economical , political and army and even cultural eras in one geographical space . After collapsing communist united, America wanted to dominance as the great power in regions that before it was under dominance and union of soviet republics. 2001 eleven September and America army invasion to Afghanistan created a space that was a road to America middle Asia strategic region. Russia that had been decreased its dominance region, because of problems after 1991 Gregorian year, suddenly was confronted with its old rival in privacy yard. NATO efforts for developing to east, fear from decreasing international credit, Russian minorities' presence in region, great energy resources presence and competition with America were problems that caused Russia put near foreign in the top of foreign politics programs. American strategy in dominance on energy resources and controlling on its transmission lines and also compete with terrorism, needs more army and political presence of this country in this region. But for Russia, America presence and dominance is considered as potential threat. America army presence in south of Russia parallel with NATO expansion to east for economical and security benefits of Russia is considered as important worry. Russia always by insisting on its positions in middle Asia emphasizes on this point that America should committed to determined time period and exit its army forces form region, when army activities will finishes.

#### 1.1. Russian and American foreign politics in middle Asia region after eleven September:

United States of America had had dynamic and active foreign politics as a powerful country. 2001

eleven September in America caused redesigning international security environment and expended changes in foreign and security politics priorities and in fact is influenced other foreign politics priorities of this country. This changing direction had important incomes on Russia and America relations and totally with middle Asia countries. united states of America in comparison with new autonomy governments in middle Asia , continued American public procedures in using new facilities for reaching American national benefits . these are incentives that united states of America assess all of changes in political and economical space according to them and its perception from its place in world to see if it can use new conditions for following its national resources or “ for following democracy “ or not(Smith .T. 1995).America constructed its strategy in middle Asia for preventing from creating powerful in region , because in American viewpoint the more regional forces are independent , the more will be dangerous for that country benefits . Now, implementing this politics has been caused creating different challenges between Russia and America, because Moscow has conflicts with Washington for determining its dominance region and wants creating and stabilizing forces its environment (Dannreuther, R.2000). Russia spent severe conditions as the main soviet kingdom survivor in its birth time in 1991 Gregorian year. the main problem of Russia was unorganized economical condition of this country that even caused Kremlin decreased his wants against foreign powers such as . but with increasing growth of energy cost at the end of ninetieths decades and parallel with it changes in Russian leader frame , this country could dominated on problems(Lapidus, G.W.2001 ). With puttin power in 2000 January and economical, political and social conditions development in Russia and also, America presence in Afghanistan, Russia paid

attention to middle Asia again. Because in nineties decade because of more problems, Russia didn't paid attention to its environment regions and wants to organized internal conditions. Russia has more benefits and more interests in middle Asia as main regional actor. This region is so important for Russia. Because Russia can parade to have more dominance on this region as a power in region. Russian politicians have been known middle Asia as their dominance heel at the end of nineteenth century. Today, they also worry for geo politics changes in middle Asia and wanted to remove security threats (Smith, M.A. 2002). In Moscow viewpoint, previous republic should be remained in Russian dominance region. in Michael riokin viewpoint, new autonomy republics, are like karaieb countries that are under American mastery (Pushdor, Alexik (Winter 1993). but for Russia, security collaboration an presence and American army dominance in middle Asia, is considered as unprecedented threat. it is clear that if eleven September didn't existed, Russia never didn't bear American army forces presence in its traditional dominance region. today, middle Asia region has been converted to interaction and competition of two main powers of cold war, means Russia and America and these countries wants to work their politics for national benefits. both of countries have advantages for following their purposes in comparison with their rivals, in below we survey some of these advantages:

### **2.1. Russia superiorities in comparison with America in region:**

#### **1.2.1. – Army power in region:**

By flowing oil incomes in last year's, Russia governments have been thought about reconstruction and updating army forces and defense industries. Russia was the greatest weapons exporter in world from 2001 Gregorian year up to now. And solely have 30 percent of weapons sell in world. according to a program that will be implemented between 2006 to 2015 Gregorian years, Russia government wants to update army facilities of this country with two hundred million dollars cost. This is while; army Russia cost has been fourfold from 2002 to 2006 Gregorian years (Peimani, H. 2002). Absolute army superiority of Russia caused this country didn't have so much problem in advancing its purposes. Russia have launching pad in Kazakhstan and radar station in sari shanganti, that is one of first alarm systems. Russian sea army force has international communication center in iskok kol. There is space preserving station in nork in Tajikistan (Carley, P.1995).

#### **2.2.1. Shanghai collaboration organization:**

Shanghai collaboration organization that is included 43 percent of today world population, is syndicated in 1996 Gregorian year and five years after collapsing soviet united. China, Russia, Kazakhstan,

and Tajikistan first signed a declaration with decreasing stress purpose and also army collaboration reinforcement. This declaration caused creating shanghai collaborations organization in 2001 Gregorian year. And in that time Uzbekistan joined to this declaration. Also after this time, Mongolia, Iran, china and Pakistan joined to shanghai declaration as supervisor members. Shanghai collaboration organization basics that was signed by all of members in 2002 Gregorian year, is emphasized on this organization don't act against any country or international organization. Despite of that, this organization is considered as a regional organization, gradually has been considered as a replacement against NATO and America dominance on middle Asia. Shanghai declaration importance isn't a economical affaire for Russia in first priority, but it is a subject that is tied by Russian security strategy before everything. This declaration is considered as leverage for Russia against American army station expansion in neighbor countries with Russia. Also, middle Asia countries leaders see this declaration more different with other declarations. Shanghai declaration is considered as confronting leverage for this group with colorful revolutions against their autocratic regimes (Plater-Zyberk, H.2002).

#### **3.2.1. Residential Russian minorities in region:**

Middle Asia countries placed similar complex of different ethnics and people in themselves. Ethnic majority usually is considered as a threatened agent of social security. The more ethnic and language integrity is equal; we can claim that that country has high degree of social security. In all of middle Asia countries, ethnic problem and other ethnic groups always is discussed as a disturbing and threatening agent of social security. Threaten that is present in all of middle Asia countries, Russian minorities presence that is considered as main pressure Russian leverages. Today, about 30 percent of Kazakhstan population, 12.5 percent of population, 5.5 percent of Uzbekistan population, 4 percent of Turkmenistan population and 1.1 percent of Tajikistan population are Russian residential. Residential Russian people of these republics are responsible for sensitive posts in political sections, army – industrial complexes, army forces and security services, and play important role in preserving and continuity of Kremlin dominance (Vernon Loeb, 2002). In addition to this, Russia according to a rule let to army force to interfere in all of independent countries for preserving Russian minorities in that country, when minority's situation is in danger in that countries and this means that permanent threat against national security in all of region countries. Presence of these minorities is a positive score for Russia against America efforts for dismissing these countries of Russian government.

**4.2.1. Common benefits countries society (CIS):**

The most prominent Russian action after collapsing soviet alliance , for adjusting multi dimensional army security structure that is consist of middle Asia , creating common benefits countries organization ( CIS ) according to Tashkent declaration . Russia wanted to unite these countries in CIS region through helping to reconstruction army units in middle Asia countries and converted them to near Russian alliances prevent from foreign powers access to Asia. This country declared “group security declaration” in 1992 Gregorian year in Tashkent by Kazakhstan, White Russia, Uzbekistan, Tajikistan, Armenia (Lank, S. 2002) and convinced member countries for signing declaration creating peace preserving force, and was responsible for peace placement in crisis regions. in new doctrine , foreign politic of this country that was so-called “ Russian foreign politic concept “ has been emphasized on convergence procedure reinforcement in CIS , reciprocal and integral relations development with member countries and its development program in a determined period to 2005 Gregorian year (Ministry of Foreign Affairs of Russian Federation 2000). totally , Russia try to keep them in economic era especially in energy and relation to itself , in addition to intensifying and making rapid of convergence procedure of common benefits countries society . also , in security background , first in addition to continues presence in strategic regions especially crisis region , try to preserve controlling previous soviet borders and second control directing and managing crisis that can be a background for west dominance and exploit them for controlling foreign behavior of region countries .

**3. Comparison table between Russia and America foreign politics tools in middle Asia:****1.3. The comparison between foreign politics tools of Russia and America in middle Asia:****1.1.3. Foreign politics tools of Russia:**

- 1 – Army power in region.
- 2 - Shanghai collaboration organization.
- 3 – Residential Russian minority in region.
- 4 – Common benefits countries societies (CIS).

**2.1.3. Foreign politics tools of America:**

- 1 – Media power.
- 2 – Middle Asia countries support of America presence in region.
- 3 – America exploitation of NATO in middle Asia.
- 4 – America exploitation of democracy in middle Asia.

America tools for dominance on middle Asia:

**1.2.1.3: Media power:**

Media power and control on world multi media that today converted to one of main tools for governments for shaping world public thoughts and drawing attention and other countries support, create one of main agents of government’s power. This is while this era was in west countries and top of them

America’s authority and Russia didn’t have more share in this era. albeit , in last year’s , by installing multi language network in all around world try to compete in this era , but it isn’t seen that government has ability to challenge America and west government on media era in short term and midterm.

**2.2.1.3: Middle Asia countries support from America presence in region:**

Middle Asia countries leaders despite of abundant differences in their foreign politics , after eleven September happening were welcomed from political and army American presence , these countries incentive has different reasons for supporting from America government , such as :

1. Developing economical conditions: the first incentive is financial need and economical bad conditions in these republics. They hope to America economical support and international organizations for developing their economical problems that is background for security, economical and social threats against their governments. After America army presence, economical and technical supports of these countries have been developed to region countries so much.

2. Repressing Islamic movements: leaders of these countries hope to repress semi armies Muslims that are residential in middle Asia in Forqane valley and had close relation with Alqade fights and are considered as main threat against security and their governments. according to security structures and army shortage in these republics , they don’t have ability to confronted with these threats and existent security structures in region , it means that rapid reaction of group forces and shanghai organizations don’t responsible for their security needs . rapid reaction forces that was created in 2001 may 25 in same benefit leaders meeting in iravan, don’t have enough readiness and they need to collaboration and cooperation of region governments and they were directed more by Kremlin . Also, shanghai collaboration organization don’t have determined army and defense structure. so , most of leaders of these countries see as stable agent to America army presence that can prepare their economical development in secure and reliable environment , in addition to decreasing these threats .

3. Preserving national governments against Russia: because of several years’ soviet alliance government in middle Asia region, Russia always has natural government on this region even after their autonomy. Top of these countries always see their national government in danger from Moscow. So, after America invasion to Afghanistan and this country presence in middle Asia, governments of these countries support America presence in region for preserving and stability of their national governments against Russia and even they let America to install army bases. united states of

America try to use this governments worry from army and political and technical dependency for their benefits and by provoking national feelings in foreign politics , not only demoralize Russia position as power center and convergence polar in region , but also strength their positions in middle Asia and south of Asia (LUZYANIN S. 2011).

### **3.2.1.3. American exploitation of NATO in middle Asia:**

Really, NATO has been presented a network of different scientific and technical to economical and political procedures in central Asia for attaining its purposes to last decade of twenty first century. also , in twentieth century NATO invented internet connection propagation between Caucasus and middle Asia that has been presented in great frame of virtual silk road and has been passed important stages of this innovation in middle Asia and Afghanistan (Jones A. Elizabeth, 2001) but eleven 2001 September was carrier of situation for NATO and was a important phenomenon for middle Asia region, because after west Europe that inclined to membership in NATO , today also middle Asia more than virtual cooperation and far from center , see benefits and NATO activities in expanding this organization to this region's countries . Especially, stable freedom operations and ISAF forces in Afghanistan needed NATO army presence increase in middle Asia countries. Several weeks after eleven 2001 September, tony beller that time president in England proposed to substitute new security organization (PJC). a week after this proposal , in NATO and Russia collaboration committee meeting ( NRC ) and in meeting in Moscow with NATO secretary - general George Robertson and Russia president Vladimir pottin discussed and consulted about collaboration in three terrorism , armament control such as developing nuclease weapons and preserving peace. (Yavuzalp, O.2002) that needed convergence to west because of Russia economical and political purposes. So, first agreements were done for convergence. So, at the end of 2001 Gregorian year, after America invasion and its allied countries to Afghanistan, with collaboration increase between middle Asia countries, NATO introduced itself as an actor and security organization in middle Asia. albeit , in this section two branches were created in NATO , in one hand America and on the other hand was European NATO , that they had differences and conflicts with each other about subject and degree of using army forces and innovation in directing army collaborations . because of this reason , ISAF with European counterparts patronage in 2001 December 20 declaration , security committee in nations organization were responsible for preparing Kabul security and its around regions . But these efforts weren't confronted so much with Washington

welcome. America didn't want to give this war command to NATO like Kosovo war (Cheng Ning, 2005). In 2004 January meeting in Istanbul meeting, NATO leaders emphasized on middle Asia increment of middle Asia importance and they named this region in addition to Caucasus region, "special focus". Also, they accepted about liaison leader disposition in regional command organization in almaty , Kazakhstan for supporting of NATO and SOS programs to region . Despite of existent differences in NATO between America and Washington European counterparts, NATO is considered as an army supporter and reliable counterpart for America. As, NATO presence background in middle Asia was prepared by creating backgrounds of America in last decades of twentieth century.

### **4.2.1.3. America exploitations of democracy in middle Asia:**

Democratization and transformation to democracy is one of important subjects that was considered in past and especially is considered after happening eleven September incident and great middle east pattern . today , according to being universal phenomenon and governments interactions and human societies intensity , democracy speaking were placed in people minds so much that apparent opposition isn't possible with this and also , even dictators in countries used democracy for preventing from internal and external pressures and governments and country named themselves democratic . So, America tried to progress its purposes with continuity and organizations expansion and democracy liberal values in middle Asia and exploitation of democracy popularity, in addition to preventing from other powers prevalence in middle Asia region.

### **4. Discussion:**

Middle Asia and Caucasus because of geostrategic position , security importance , existence some of crisis and ethnic differences , existence of energy resources and its transportation to consume markets always has been considered by regional and infra regional powers . Russia deficiency after collapsing and west oriented procedures government caused less attention to middle Asia and Caucasus that at last power shortage was created in this region . New conditions after collapsing and geo politic benefits in region cause competition between different powers for presence and dominance in this region. After puttin reached to power in 2000 Gregorian year Russia changed its procedure against region. Middle Asia and Caucasus are considered as geo Russian strategic and geo politic depth in Russian leaders mind. Moscow's more dominance and presence in this region causes Russia international and regional position increase and Russia national benefits in strategic, security, political and economical reconvergence with dependant

republics such as Caucasus and middle Asia. In this frame, Russia rivals control and adjustment are one of Moscow's proposes .west powers with exploitation of security and economical benefits try to increase its dominance and presence. in this case , NATO by implementing " collaboration for peace " and " Europe - Atlantic cooperation committee " programs , try to prepare west political and strategic purposes . in addition to this , west by presenting educational programs and economical and financial supports and financing for transforming energy from east to west and presenting support for solving problems try to prevent from Iran , china and Russia dominance that are parallel with west politics and benefits . Caucasus and middle Asia countries , because of worry of Russia dominance return and need to economical and financial supports tended to interaction with powers and organizations and multidimensional institutes in one hand , and on the other hand , economical infra structures of this countries dependant to Russia that was heritages soviet era and security problems and ethnic differences and presence some of crisis were caused these countries couldn't deny relations and collaboration with Russia . Important point in independent countries is foreign politic should go ahead with government's survival and help them for solving problems and collaboration and alliance and multidimensional collaborations are welcomed until they were in foreign politic services. First competition in Caucasus and middle Asia are between Russia and west especially untied states of America

#### **Acknowledgements:**

Author is grateful to Abdanan branch, Islamic Azad University for financial support to carry out this work.

#### **Corresponding Author:**

Mahdi Nouri  
Abdanan branch, Islamic Azad University,  
Abdanan,Iran.  
Email:NouriMahdi3@ymail.com

#### **References**

1. Carley, P.1995. The War in Tajikistan Three Years On, United States Institute of Peace, Special Report.

2. Cheng Ning, 2005 .“The Current Situation in Central Asia”, *JSS*, 3-, pp. 34-35.
3. Dannreuther, R.2000. Russia's Eurasian Security Policy, Geneva Centre for Security Policy.
4. Jones A. Elizabeth, 2001. "U.S.-Central Asian Cooperation, "Testimony to the Subcommittee on Central Asia and the Caucasus, Foreign Relations Committee, U.S. Senate, December 13, , p. 9.
5. Brown J. Mammals on mountainsides: elevation patterns of diversity. *Global Ecology and Biogeography* 2001; 10(1):101-9.
6. Lank, S. 2002. The Shanghai Cooperation Organization and its Future, *Central Asia-Caucasus Analyst*.
7. Lapidus, G.W.2001. Central Asia in Russian and American Foreign Policy after September 11, , Berkeley Program in Soviet and Post-Soviet Studies Articles, 2001 (pdf).
8. LUZYANIN S. 2011.*SCO: Security Problems and Prospects for Cooperation in Eurasia*, in «Far Eastern Affairs», vol. 39, no.1, , p. 24.
9. Rawat YS, Singh JS. Forest floor, litter falls, nutrient return in central Himalayan forests. *Vegetatio*, 1989;82(2):113-29.
10. Peimani, H. 2002 . American Military Presence in Central Asia Antagonizes Russia, *Central Asia-Caucasus Analyst*.
11. Plater-Zyberk, H.2002. Kazakhstan: Security & Defence Challenges, *Conflict Studies Research Center*, September (pdf) .
12. Pushdor, Alexik (Winter 1993), "Letter from Eurasia: Russia and America: the Honey Moon over" , *Foreign Policy*, vol. 25,No. 1. PP 80-89.
13. Smith .T. 1995. American's Mission: The United States and the Worldwide Struggle for Democracy in the 20<sup>th</sup> Century princeton . N.Y.
14. Smith, M.A. 2002.Russia, the USA and Central Asia, *Conflict Studies Research Center*, May (pdf).
15. Vernon Loeb, 2002. "Footprints in Steppes of Central Asia," *The Washington Post*, February 9, p. A9.
16. Yavuzalp, O.2002. On the front line, NATO's relations with Central Asian Partners, *NATO Review*.

9/17/2012

## Comparison the policies of west (United States America and NATO) and East (Russia and Shanghai) in the Middle Asia

Ali Hamid

[HamidAli@gmail.com](mailto:HamidAli@gmail.com)

**Abstract:** After the Cold war era and creation the power vacuum in some world areas, the multilateral and regional organizations significantly developed in globalization age. Middle Asia and Caucasus were from the most important areas that faced power vacuum in the new international system and Russia federation as the main heir of Soviet Union from one side and The West collection from the other side attempted that benefit that conditions with adopting various methods. Formation and strengthening the regional organizations are been considered as the most important approaches of both to coordinate Middle Asia countries and Caucasus with own goals, benefits and policies. The present article try to investigate Russia policies and west powers as two main actors of developments in that area within the comparison policies that have tried to create alliances, coalitions and new organizations for own special preferences, benefits and goals or they try to join coordinator countries to own specific organizations.

[Ali Hamid. **Comparison the policies of west (United States America and NATO) and East (Russia and Shanghai) in the Middle Asia.** *Life Sci J* 2012;9(3):2680-2685] (ISSN:1097-8135). <http://www.lifesciencesite.com>.

**Keywords:** America, Russia, NATO, Shanghai, Middle Asia

### 1. Introduction

Historically, Caucasus is one of the oldest and the most important centres of human civilization that it was a section of Iran. It frequently has been changed hands between Iranian, Roman, Greek civilizations that Tsar Empire dominated it gradually. It was exchanged to contrast scene and Russia, UK, Iran and Ottoman competitions called "Great Game" beside the Middle Asia in the end of the nineteenth century and the earlier of the twentieth century. In terms of cultural, Caucasus is the collision place of Islamic and Christian civilization, Russian culture, Aran and Turkish, Pan-Turkism thoughts and also it is habitat of more than 50 ethnic groups. Economically, this area has significant resources of oil-gas and rare metals. It is path of energy transit Middle Asia and Caspian Sea to Europe so according to neighbourhood of Central Asia and Caucasus with Caspian area, it has important position in the calculations of regional and ultra-regional countries, because Caucasus is been mentioned as entry gate to Middle Asia that has been collision place of Warsaw and NATO contract. Also according the geopolitics theories, it having geostrategic and geo-economics dimensions is from areas that being a section of Hartland in Eurasia beside Middle Asia is very important in Halford Mackinder theory and it is field of great powers collision. While the countries of Middle Asia and Caucasus always welcome to alliance and coalition strategy in order to supply of own benefits in the different political, economic, security fields and maximizing own benefits for the internal problems and security concerns. Because of the security and economic considerations specially fear from Russia domination, some of the countries

have paid attention to the west in instructions to create the balance (Blua, Antoine. 2004) . We must note to intensity and weakness of their look at the west. Some of them follow confederacy approach with west and other profit by economic advantages of West; while they like having the west for need time because of historical concerns.

#### 1.1. Russia and Middle Asia:

Despite Russia decline and separation the Middle Asia and Caucasus from framework of that country, the basic and strategic importance of Middle Asia and Caucasus maintained for Moscow and the Russians that were owing an historical and strategic thought against that area, followed the ancients conduct. The political changes after the decline don't show that basic changes in look at the Middle Asia Caucasus in politicians priorities of Moscow. We must search the root of this long-lasting tradition in the belief of some of the Russian geniuses that believe the Russia influence and presence in the Middle Asia countries and Caucasus can supply the Russians benefits. They referred the role of Russia in the civilizing those societies and its historical achievements such as defence from Georgia against Turks in the end of the eighteenth century protection Ukrainian against Polishes in the seventeenth century that they were very vital and important. So Russia always treats that area very important and follow to supply own benefits (Rall, Ted. 2006). Accordingly, one of the important discussions in Russia after decline is the plan of security benefits field in the former Russia. So the first strategy Russia was prepared in 1992 that the geographic area of the former Russia mentioned as the Russia national

security area. This approach was strengthened after Yeltsin. The Middle Asia and Caucasus are a component of Russia national security benefits area and it is considered as a geopolitical area. The resident people in this area have lived within a country for a long time. Russia is very sensitive to the fate of the Russian minorities in those countries. Protection the Russian race is an important element in the regional policy of Russia that the Russian politicians consider it today. So that if the political behaviours of powers be against to expectations and goals of Russia, its policies and influences cause to not achieve the rival strategies to expected results. So if a power tries to weaken Russia in political field and finally area geopolitical, it will confront resistance and reaction of Russia. Because if Russia be weakened in that area, the competitors enter to it and this will damage Russia security. So it seems that despite the defects of Russia policy in area that caused by new conditions and independence of the new countries, there are the conditions that other countries follow own goals in the Middle Asia and Caucasus. So in the new conditions, Russia try that if it can't be the sole influential and determining power in the Middle Asia and Caucasus, at least it can prevent playing such role by others. On the other hand, Russia benefits in south Caucasus are very similar with benefits of NATO members, but approach of Moscow in that area is completely different from west (Murat Laumulin. 2007). The basic attention of Russia is confidence from security of south borders of this country. Moscow wants to have the good relations with three countries in Caucasus, because having such relations increases the power of this country to maintain the stability in North Caucasus. Although Russia has great reserves of oil and gas, but it has a great tension to hydrocarbons benefits in Caspian, so Russia like to keep west away from what is the specific benefits of it.

### 2.1. Policy of U.S. in the Middle Asia:

The strategic and geopolitical situation of Eurasia has made inevitable the presence of U.S. While U.S. extends own opportunities in the politics, economics and security fields, it wants to obtain a base to control Russia, China and even Iran. So we can divide the foreigner policy of U.S. to two times before and after the 11 September event. Before the event policy of United States was preventing the ideological and radical of Russia, preventing development of the nuclear weapons that they have remained from communism era, stopping Islam development and radical against west in area, completion of Iran siege, domination on natural resources of area and protection from democracy and

free market economy and preventing and controlling civil wars that 11 September event in 2001 caused the rotation foreigner policy of United States. United States noticed to that event more than Eurasia. After the terroristic attacks in 11 September, Moscow agreed with America request based on the militaries access of that country to the former Russia bases in the Middle Asia and Caucasus. So America could conclude several short martial contract with Kyrgyzstan, Uzbekistan, Tajikistan and Kazakhstan in order to establish the militaries of that country and use of their bases and military equipment that is was the first step i.e. the military presence of America and in the next step it decided to play a role in the regional problems and promote the security orders that were improbable and change the martial and defensive structures from eastern system to western one. However, Russia came to an agreement with martial presence of America, but it created some challenges to the presence of that country in Caucasus that is vital for Russia. The existence the crisis in the area can cause to be lost north Caucasus. For Russia control on that area it could influence on strategic policies of energy and world policies of oil pipe lines and energy transition. Anyhow as mentioned, the United States goal after 11 September is domination on Eurasia, because Hartland Mackinder view is very important yet. Because of that America acts in several forms to be present in the Middle Asia and Caucasus preventing formation the martial contracts and unions with the different forms from Iran, Russia, India, China and some of the Middle Asia governments such as Shanghai organization. Because of not having access to that domain from east and west, it had considered Caucasus the gate of entrance to that area being Georgia republic the first step. Because that country is very important for its geopolitical and geostrategic situation. After 11 September events, it has tried to power the faces with the change of region leaders that the people be relatively satisfied them and they be related to America the enforcer of Washington policies. We can point at support NATO development to the east and the martial westernized contracts such as Guam and also granting the pecuniary, technical and martial aids to above - mentioned republics.

### 3.1. NATO

The survival necessity and martial costs of NATO were considered exactly with decline of Russia and ending the cold war. The structural realistic believed that it doesn't need the survival cost of NATO with decline of rival power. Against of it, the neoliberal institutionalises believed that although the communism threat has destroyed, the principle



one has maintained yet. Finally, view of institutionalises convinced the heads of NATO. They undertook in the public meeting in 1991 that NATO will survive with dissemination of spread to east. NATO redefined own nature, goal and structure by that approach. According to importance of area for the west, NATO entered to the area by performing two plans that one of them performed via creating the cooperation council of North Atlantic and the other one was to fulfil the participation plan for the peace. The participation plan for the peace was designed to observe on the military forces, doing the joint operation that NATO guided it and the communication between the member states. NATO documents indicates that the partnership program for the peace enables the member states to strengthen own relations with NATO for their benefits and capabilities. The participation exercises have been designed for the peace in order to promote the practical military cooperation.

**Table1: comparison the Russia and U.S. in the Middle Asia:**

	U.S.	Russia
<b>Russia and U.S.</b>	1-control and weakening Russia 2-control of China in area 3-confronting with Iran influence 4-access to energy resources of Caspian sea 5-strengthening and influence of Israel in area 6-preventing fundamentalism growth 7-preventing nuclear weapons development remained from communism era 8-complete the Iran siege 9-domination on the natural sources of area 10-support the democrat and free market economy 11-prevention and control the civil wars	1-obtaining the past role and influence again 2-maintaining stability of the area 3-preventing influence of the foreigners in the Middle Asia 4-continuance the connection of the communication structures with the external world via Russia 5-transit the energy resources to the world usage markets by the oil and gas transition lines of Russia 6-strengthening own place as one of the basic suppliers of the economic and technologic needs of these countries and preventing their convergence with the west structures 7-maintaining the rest monopolies from Russia era in area maintaining their connection with Russia 8-use the first resources and the raw materials of area countries 9-transit the part of goods and products of area to north of Europe specially for the republics not having a way to the free waters 10-use the ways of area to commercial connection with Iran and the countries of the south of Asia

And the joint capabilities in the states that the program emphasises on them and also to help to develop the cooperation capabilities between the allied forces of NATO and the partner countries. Thus the identity of NATO was changes from the nature of a defence treaty to a development – oriented power and gazed to more than the geographic area of Caucasus Middle East and Middle Asia. In this regard, NATO has presented a network from the various scientific, technical, economical and political strategies in order to reach own goals in the Middle Asia since the last decade of twenty – one century, also NATO presented the initiative of promotion the internet connection between the Middle Asia countries and Caucasus within the virtual silk highway and now it has traversed the important steps from that initiative in the Middle Asia and Afghanistan. It replaces the management of the international crises, extreme nationalism, fundamentalist; terrorism and struggle with the proliferation of mass destruction weapons with own previous goals i.e. the communism control. NATO considered a special place for their own in the Middle Asia and Caucasus by that strategy. The increasing number of member states from 16 to 26 and effort of Australia and Japan on military connections with NATO are some examples from structural changes in NATO. Now all of the countries of Eastern Europe are members of NATO. Thus, NATO has organized the sensitive connections for Russia, Georgia, Azerbaijan and Ukrainian. From the view of Russia, that area is been considered as a security domain. Moscow defined destroying that area, disruption of the stability and balance of the area powers. So Russia considers it as red channel. But NATO hasn't considered these warning signals seriously. It draws own regional policies with criteria of the power balance. So it considers process of spread to east as an inhibition policy against the potential threats of area. In this approach, the process of combat with terrorism, preventing the proliferation and publication of mass destruction weapons and confronting with fundamentalism and efforts to spread the democracy along that inhibition strategy and establishment a hegemony power in area finds meaning. In this approach, the spread of NATO to east is a means to institutionalize hegemony of U.S. in Eurasia. U.S. is able to prevent the appearance any rivals in area by these political leverage. U.S. always thinks about the unipolar system with own leadership after the cold war and fears of new rivals such as Europe and China. So U.S. tries to play the basic role in the international changes by maintaining own excellence in institutions such as NATO. Although the Security Council as an efficient tool can be an appropriate assistance for expansion of U.S., but the

existence of the strong oppositions of U.S. such as China and Russia in the Security Council has decreased largely the possibility of relying to that. According to the powerful and executive role of NATO in the world, today that organization is a valuable tool more than ever. After the cold war of NATO it considered the plan of spread to east in the international system by the broad definition of security threats in order to maintain the stability in different areas in the world. Therefore, the long-term goals such as dominance on the geostrategic and geocologic of area, management of the immense resources of petrochemicals of area, confronting with countries that manufacture the nuclear and chemical weapons, confronting with Islamic fundamentalism, information exchange, preventing the formation of the traditional power of Russia in area, diffusion barrier of spread China power, blockade of Iran, to pressure the Pakistan, alongside compete with power of India are some of goals of U.S. that only achieve them via power of NATO. So it seems that in association with security issues in the Middle Asia and Caucasus, two security organizations and Europe cooperation and contract organization of North Atlantic (NATO) act co-ordinately. NATO follows the spread of military relations, information exchange and doing the joint maneuvers with countries of area within the participation plan for the peace, while the security organization and Europe cooperation act resorting to various political practices such as early warnings, preventive diplomacy, humanitarian aids and management of crisis via mediation in conflicts and other peaceful methods of the settlement of disputes. Indeed, these organizations are complementary of each other about the security issues.

#### 4.1. Shanghai

Indeed, the cooperation organization of Shanghai is a soft balancing against hegemony of U.S. The appearance and evolution of cooperation organization of Shanghai potentially is a balancing act in reaction to U.S. unilateralism. China suggestion to form the cooperation organization of Shanghai is a reason to opposition of that country with American view of the international system and U.S. claim about unipolar world. The increasing presence and influence of U.S. in the Middle Asia specially after 11 September and occupation of Afghanistan has become a security concerns of China that has caused to cooperate China more seriously and institutional with neighbouring countries within the cooperation organization of Shanghai creating the balance with coordination of Russia against the growing influence of U.S. Peking leaders have considered the view of multiple system in contrast to

unilateralism of U.S. in different occasions. However, until 2001 and even in recent years, that organization has frequently announced that it doesn't try to form the block against U.S. and west (Navrozov, Lev. (2006). The main activities of that organization are within areas of business, investment, economic and financial affairs, education and culture. From 10 mechanisms of cooperation organization of Shanghai, 4 groups are belonging to Eden policy affairs (economy, transportation, culture and parliament), 4 groups to law and order (border affairs, attorney, law and emergency cases), and only 2 groups are related to defence and state. But it doesn't mean that the organization is incurious to growing presence of NATO in area. As Shanghai has increased the quantity and quality of own military manoeuvres in area against exercises and military training cooperation of NATO since 2003. In July 2005 Shanghai in cooperation with NATO in Afghanistan in condition of determining schedule agreed to get out of Uzbekistan and Kyrgyzstan. After leaving Uzbekistan and U.S. attempt to increase the presence in Kyrgyzstan, Shanghai tried to power off to U.S. by doing the military manoeuvres 2005 in China and 2007 in Russia. On the other hand, in Astana summit in 2005 it emphasised on the collective action strategy against foreign terrorist plots or expansion with spread of terrorist threats (Stakelbeck, Frederick W., Jr. (2005). In addition, after that summit, struggle with racial separatism and extremism added to its tasks. Also, the members of organization were committed to supply the stability in area, struggle with terrorism, separatism and extremism act intercommunion and coordination in order to promote the cooperation. In addition, in 2006 it announced in a statement that the members of that land don't use themselves to compromise the rule, security or the territorial integrity of the other members and don't allow to those organizations and other groups to activate that they compromise the other member benefits. After strengthening and security jobs of that organization and interest of Russia and China to prevent the military and security interventions of the ultra-regional powers specially U.S., this organization asks U.S. in heads summit to determine program of exit of the military powers from area. Indeed, the close cooperation of China and Russia as two permanent members of the Security Council in area has encouraged the member states to convergence and more cooperation with the organization.

#### 5.1. The contrast and cooperation Shanghai and NATO in the Middle Asia:

We can evaluate the complex and invisible relations of NATO and Shanghai in the new

conditions of the Middle Asia in the analysis of the competition and reconciliation components. Two clear characteristics in the Middle Asia affect the spread of NATO to east and the military policies of U.S. in area geopolitically and geoeconomically. The Middle Asia geopolitically locates in vicinity with 4 areas of the Middle East via the shared borders with Iran, vicinity with Indian Subcontinent via the shared border with Afghanistan, Caspian Sea, Russia and also China. Establishment in this area for U.S. means to access to centres of threatening. On the other hand, the importance of energy resources of that area in the future has made U.S. sensitive to increasing Russia influence in the Middle Asia. In the early of summer in 2009, the energy information office of U.S. (EIA) predicted the intense decreasing of world oil reserves. According to Michael klar the cheap oil era is going to finish and likely the lethal competition will begin for energy. According to Pip Skobar, Afghanistan war isn't for the terrorism, it is for the energy. He is one that by expressing Pipelineistan term and the explanation the pipeline claims that Afghanistan locates in centre of energy transition and then he says: Do not "Afghanistan" and "oil", because they are similar. Indeed, we can say that many of the geopolitical and geoeconomical calculations of powers of the Middle Asia rotate about axis of energy and it unites the west in Persian Gulf wars in last decade of twentieth century and then Afghanistan and Iraq war in the first decade of twenty – one century, so it seems that Russia in addition own lone – riding policies in the energy markets in area and world, now is sought to create a east energy block. Simultaneous with summit of Shanghai heads in Bishkek in August 2007, Kremlin announced that he has decided to create an energy club among the members of that organization. It means more dominance of Russia on the energy markets and so the political exploitation from that economic instruments against west. But despite the mentioned conflict backgrounds in the Middle Asia, U.S. and NATO from one side, Russia and China i.e. Shanghai from other side have some shared concerns that it can provide the compromise and cooperation background of these two fronts. The existence of the shared threat called terrorism, drugs and organized crimes are the axis of that compromise that is an intolerable threat to them. In recent months, they have been called by NATO officials, Russia, China and Shanghai to cooperate in order to finish Afghanistan war. It seems that China is more interested in these discussions and Russia is urgent to guidance these cooperation. Making a formal discussion with cooperation organization of Shanghai may help to strengthen the role of NATO in the Middle Asia countries. However, NATO is lacking of formal relations with that organization or China

(Colson, Charles. ( 2003). The regional issues such as the social and economical development, energy utilization, struggle with terrorism and drug trafficking inhibition, control of the mass destruction weapons, cooperation in the management of the natural disasters can provide the background to strengthen NATO negotiations.

**Table2: comparison Shanghai policy and NATO in the Middle Asia:**

	Shanghai	NATO
<b>Comparison the policy of Shanghai and NATO in the Middle Asia</b>	1-creating a barrier against the security threats from Afghanistan, Iran and Pakistan 2-maintaining the stability of area 3-preventing terrorism and separation in Syngjiyang province 4-to access to the energy resources 5-creating the block of east energy 6-creating a powerful force against hegemony policy of U.S. patriarchal Power	1-struggle process with terrorism 2-preventing proliferation and publication of the mass destruction 3-contrast with fundamentalism 4-effort to promote democracy 5-establishment a hegemony power 6-inhibition of China and Russia

## 2. Discussion:

The regional and ultra-regional powers always have considered the Middle Asia and Caucasus for their geostrategic situation, security importance, existence some crises and ethnic differences, existence energy reserves and its transit to usage markets. The weakness of Russia after decline and westernized approach of Yeltsin state caused to low note at the Middle Asia and Caucasus and power vacuum in that area. The new conditions after decline and the geopolitical advantages of area caused the competition between different powers for presence and influence in that area. After Putin came to power in 2000, Russia changed own approach to area. The Middle Asia and Caucasus within the thoughts of Russia leaders are the depth of geostrategic and geopolitical of Russia. The more presence and influence of Russia in area cause to increase the regional and international situation and national benefits of Russia in review the economic, politic, security and strategic integration with independent republics in the Middle Asia and Caucasus. In this framework, control and moderating

Russia competitors are goals of Moscow. West powers try to increase own presence and influence in that area by use economical and security advantages. In this regard, NATO tries to supply the political and strategic of west by performing 'partnership for peace' and 'partnership council of Europe – Atlantic' programs. In addition to, west tries to prevent influence of Russia, China and Iran by presenting the educational programs, the financial and economic assistance and investment to energy transfer from east to west and help to settlement of disputes.

**Acknowledgements:**

Author is grateful to person for support to carry out this work.

**Corresponding Author:**

Ali Hamid

Email: [HamidAli@ymail.com](mailto:HamidAli@ymail.com)

**References**

1. Blua, Antoine. 2004. Central Asia: Shanghai Group Opens Secretariat in Beijing Tomorrow. *Radio Free Europe/Radio Liberty*. 14 January. <http://www.rferl.org/featuresarticle/2004/01/54da009d-d0ae-48db-b68e-598c0474b23e.html>.
2. Colson, Charles. (2003). "Central Asia: Shanghai Cooperation Organisation Makes Military Debut". *Radio Free Europe/Radio Liberty*.
3. Murat Laumulin. 2007. *The Geopolitics of XXI Century in Central Asia* (Kazakhstan Institute for Strategic Studies, Almaty, ), p.135.
4. Navrozov, Lev. (2006). "The Sino-Russian 'Shanghai Cooperation Organization'" *NewsMax.com*. .

9/17/2012

## Feudalism in Iran

Zia Khazaei

Department of Political Science, Zahedan branch, Islamic Azad University, Zahedan, Iran  
khazaeiZia2@gmail.com

**Abstract:** Presence or absence of Feudalism in Iran is one of the most important political and social issues since it is an important factor explaining this country's development or underdevelopment. A European feudal ownership is quite stable while that of an Iranian owner is quite shaky, and an owner might not only lose all his power and authority but also his ownership through changes in monarchies and dynasties. Lack of European Feudalism in Iran resulted from the presence of a hereditary monarchy in Iran which prevented the creation of powerful and independent groups and classes and instead established bureaucratic landholding system which resulted in controlling agriculture and trade which in turn prevented the development of capitalism and rationalization of bourgeoisie like what happened in Europe. In this connection, Karl Marx believed that feudalism plays a crucial role in historical evolution and development of a country and it is the foundation of capitalism development. On the contrary, oriental despotism and obstinacy is the main factor of historical underdevelopment of a country and its lack of growth.

[Zia Khazaei. **Feudalism in Iran.** *Life Sci J* 2012;9(3):2686-2690] (ISSN:1097-8135).  
<http://www.lifesciencesite.com>. 391

**Keywords:** Iran, development, oriental despotism, Asiatic mode of production

### 1. Introduction

Three theories have been discussed about feudalism as a historical period in Iran in since ancient era up to now. After explaining them we will discuss another theory besides them which is defended by the other and will offer our reasons to explain and prove it.

**1.1. First theory:** It is Marxist theory which knows feudalism as a kind of historical periods which almost has been somehow created and established in all countries and according to Anderson, "Feudalism in this version of materialistic narration is an instructive ocean in which every country is actually baptized (Reynolds, Susan. 1994). The history of each country or ethnic group has distinct and separate steps which include primitive communal society, slavery, feudalism and bourgeois and each of these steps follow each other with a indestructible order (Brown, Elizabeth.1974) . Therefore many Iranologists of the former Soviet which were impressed by the events analyzed Iran on this basis and exactly used the same terms and concepts of western sociology for the institutions and events of Iran history. For example the book titled as "History of Iran" which is written by a group of scholars of the former Soviet such as Grantovski, Danda Mayo, Petrusevski , Ivanov and Blue has analyzed different periods of Ancient Persia , Arabs invasion , the ruling of Umayyad dynasty and Bani Abbas , and the establishment of constitutional revolution , based on feudalism logic. In general, according to this theory, "feudalism is the system of exploiting relatives and rural peasants by feudal rulers, they believe that the

mode of production depends on its conditions" (Reynolds, Susan.1994).

**2.1. Second theory:** believes in separating the history of the world countries and thus considers feudalism as a special part of the world. This movement root traces back to Montesquieu who wrote: "It was an even that happened only once in the world and might never be repeated again." Voltaire took a stance against such an analysis and approached Marxists stance by declaring that "Feudalism is not an event, it is a very ancient form with different governments which is governing three-quarters of our hemisphere" (Poly, Jean-Pierre and Bournazel, Eric.1991). Karl Marx and Engels, influenced by Montesquieu, considered feudalism in their analysis as particular part of the world which is related to the history of Western Europe. After studying the history of West European countries such as Germany, France, and England they understood that these countries have passed communal and primitive historical periods, slavery, feudalism and capitalism and their future history will be manifested in socialism. The question that was raised for Marx and Engels was whether these historical periods existed in other areas such as the East or not. By doing some research on Eastern countries, including Iran, India, the Ottoman Empire, and china they found that these countries had their own special history and after the communal primitive period they have entered a period which is known as Asiatic mode of production or Eastern exploitation and didn't progress in this period historically, that is why Marx believed that the East lacked history. Marks believed that due to special climate and

geographical conditions and residential areas and lack of water to irrigate agricultural land, Eastern countries needed to dig canals and to build dams and to develop irrigation projects, which actually the central government was capable to deal with. Government control over water supplies and irrigating systems would cause domination and eventually ownership of agricultural lands and thus a powerful independent class which is called aristocratic landowner is not formed because the government will rent its own land to its servants and acquaintances and will take them back whenever it wants, thus aristocracy won't be developed and nothing as private ownership will be formed. According to Marx and Engels, Lack of formation of aristocratic landowner and private ownership in these countries will have a great effect on development of these countries because in absence of such aristocratic class, there won't be any power to stand against the government or control its power. Therefore, the government will dominate all aspects of the society, and insecurity is the main feature of such societies. Karl Marx believes that feudalism has just developed in West Europe where due to proper climate conditions and sufficient rainfall, there is no need to develop general irrigating system by the government. Sufficient rainfalls and enormous water, provides the required water for agricultural lands therefore there is no need for the government to interfere and thus aristocrat landowners will grow independently and will gradually stand against the government. Marx believes that this is the main factor of capitalism development since the independent powerful aristocrats stand against the government and their conflict provides a safe environment which in turn provides the best conditions for capitalism development.

**3.1. Third theory:** Hartsfield the preacher of this theory believes that the history of Iran is in fact, nothing except a succession of royal dynasties and governments. According to Diakonov, the contemporary historian of the former Soviet, although in Europe we are witnessing the evolution and development of history from feudalism to capitalism, Asia will still remain in feudalism and it seems as if Asian tribes and ethnics are not able to promote to a higher position. Of course this theory is not justifiable scientifically and logically because if we believe in feudalism in a country, it will naturally pave the way for a historical evolution and movement. Unless we believe in feudalism opposition which is Asiatic mode of production and Oriental despotism; since according to Marx this period prevents historical development and evolution by suppressing independent groups or parties.

**4.1. Fourth theory:** This theory is what the authors believe in. First of all, Marx and Engels' theory of Oriental despotism and Asiatic mode of production is accepted about the history of the East and it is believed that Feudalism couldn't be a general period for the whole world because if we believe so, then the underdevelopment of some part of the world will not be justifiable for us. This is what Anderson also believed in. He stated that "Marx was quite aware of the dangers of irregular expansion of feudalism beyond Europe and avoided to accept that the sultanate of India, Delhi or Mongol Empire were a social form of feudalism (*Bill James A. 1963*)."

Second, as feudalism theory and its important indices such as private ownership and powerful aristocratic landowner cannot be generalized to entire world, Marx and Engels' theory of Oriental despotism can't be generalized to all Eastern countries, either. It seems that by concentrating on the history of Iran we find that the history of ancient Iran owns features and characteristics which are quite distinct from its later history which begins with the attack of Muslim Arabs to Iran. The history of Ancient Iran which typically began with the establishment of Medians and Achaemenids and continued until the collapse of Sassanid Dynasty owns the logic of Feudalism and can be analyzed and assessed with this perspective. While with the collapse of Sassanid Dynasty which typically began with the attack of Arabs to Iran a new era began which is more consistent with Marx and Engels' theory of Oriental despotism.

#### **5.1. Feudal society of ancient Iran during Sassanid Dynasty**

There is evidence about the feudal society of ancient Iran during the Sassanid era which will be referred to. One of the main features of feudal systems is the existence of independent and powerful aristocratic class. According to Karl Marx this class paves the way for capitalism development. In his book "The Spirit of the Laws", Montesquieu writes about the importance of aristocracy as: "Aristocracy is somehow a part of the nature of monarchy and its fundamental principle is that wherever there is no king, there is no aristocracy either, and wherever there is no aristocracy, there won't be any king except a cruel despot (Nomani Farhad. 1977)". If we believed in the existence of aristocracy in east authoritarian regimes, this class would mostly get pension and salary from central government and would depend on it. According to Marx, this class never became a powerful independent hereditary class because the nature of political power in the East was a barrier to the development of constant power centers. Sassanid inscriptions reflect the social structure of Iran and independent aristocrats so that "social status and positions were based on aristocracy

and the nobility of the ancestors and not based on the titles, and in some cases the names have been mentioned even without any title. But the reverse situation does not exist anywhere. This indicates that an individual was more valuable than a title and the person was the main factor but the title was just something arbitrary.” The characteristics of Sassanid aristocracy definitely distinguishes it from authoritarian societies of the East. Because this class has got its status and peerage out of the scope of the government while in authoritarian regimes of the East, aristocracy emerges from the heart of the government and might disappear as quickly as it appears. Aristocracy’s power weakened in the wake of events that occurred in the late Sassanid era. These events included catastrophic failure of the Pirouz I (459 - 484) "versus Hephthalians in the East and paying taxes and tribute to them, drought and famine, Mazdak’s revolutionary movement and the invasion of aristocrats’ properties by his followers, and finally disputes among nobles themselves (Christensen, A (1971). Of course, it was important for the Sassanid kings to subdue aristocrats not to eradicate them. That is why, according to Pei Hekou, Ghobad granted glory and dignity to a person who was a member of aristocratic family and who well deserved it. Another important feature of Feudal system was the existence of private ownership by the aristocrats according to the rules and regulations and customs of these societies while it is not found in authoritarian regimes and as stated by Marx and Engels the government dominance over water supplies and irrigation system eventually led to the ownership of agricultural lands by the government and therefore no private ownership is found in such societies. Therefore there is no example of lack of laws or etiquettes in Sassanid era in Iran while the society was involved in a process in which religious laws were changing to compiled civil laws like what happened in western states therefore rules and regulations were greatly respected so that the famous Roman historian Ammian Marcellin declared: “Iranians are very afraid of the laws, especially fugitives from military service”. Of course some believe that in Parthian, Sassanid era we are not facing dynasties in special sense but we are facing some probably hereditary positions and posts which were studied as dynasties but were actually some posts or appointments. If this analysis is true, it represents an important principle of nobility, since a post in an aristocratic family has been inherited from generation to generation so that it is difficult to recognize, for instance, if Soren or Espahbod is the name of a noble family or an official position. It seems that there has been a direct relation between aristocratic families and official positions so that only

the nobles could get official posts and conversely, if the king could rule over the aristocrats and was able to grant posts to others, even in this case he couldn’t appoint low class people to such official posts. John Badan, the 17<sup>th</sup> century intellectual proposed the theory of sovereignty for the first time and separated government and sovereignty from each other. He believed that sovereignty is the way of governing society and thus he divided monarchy to three categories: absolute monarchy, aristocratic monarchy, and republic monarchy. The first one is a monarchy in which sovereignty or the highest political power is in the hands of the king and the government is also in the hand of his appointed agents. Those who think monarchy is the same as despotism refer to such monarchy. In second kind of monarchy, sovereignty is in the hands of the king and the society is governed by the aristocrats and in the second kind the society is governed by the people’s president. In fact, monarchy in Iran during Sassanid dynasty and even Ancient Persia was aristocratic monarchy because although sovereignty was in the hands of the king, society was managed and governed by the aristocrats. Enayatollah Reza quoted on behalf of Simulate that inheritance existed in official posts and also participation of nobles and aristocrats in managing the state and country affairs (Elton L Daniel, (2001). He also wrote: “ By studying the resources and references it is implied that during the reign of Sassanid kings, there had been disputes and disagreements between the nobles and aristocrats and the king which sometimes caused serious conflicts and quarrels between them(Elton L Daniel,. (2001).” It is quite natural that signing a treaty between the king and officials and fief holders is a feature of feudal systems. Because in each treaty there are two sides which have some rights and duties in relation to each other while in despotic regimes there isn’t any treaty or agreement because the tyrant is not supposed to be confined to these treaties. Another feature of feudalism is the presence of aristocratic landowners in their farmland which distinguishes it from the East despotic regimes. In these kinds of regimes, because of despotic power in cities, aristocrats or nobles try to live near the center of power to be always aware of different affairs so that their rivals couldn’t pull the rug from under their feet, while in feudal systems aristocratic landowners are less dependent on central government and their relationship with central authority is based on treaties and contracts which are necessary to be respected by both sides, therefore they don’t need to attend urban areas and power centers and thus they stay in their agricultural lands and behave as an intermediary between the government and the farmers. Although Iran needed artificial irrigation systems due to

geographical and climatic conditions, these systems as mentioned above were provided by aristocratic landowners and not by the central government. And this is an important point which has been ignored by many scientists and researchers. Finally another important issue must be referred to which indicates that Ancient Persia was not reflecting a despotic society in domain of science and cogitation because the idea of an ideal monarch prevented the establishment of political despotism.

### **7.1. Collapse of Feudalism in Iran**

With the attack of Muslim Arabs to Iran, we witness the collapse of a civilization which can be explained based on feudalism standards some part of which were referred to before. Muslim Arabs were fundamentally in conflict with feudalism and its features and indices because it had no relation with their lives. Max Weber believed that the relationship between religion and its believers was a selective relation so that the believers finally would influence the religion and would seal it and would play a decisive role in its future (James Denham-Steuart (1767). Therefore whether we care for Islam which is based on the principle of belief and the formation of a united community or care for its believers and followers that is the Arabs whose lifestyle was ethnic and tribe-oriented, both of them are against the features of feudalism system. David Farahi believes that "political wisdom and power in Greece have risen from inside a triangle of limitation and scarcity and each of its three sides can be devoted to land, wealth, and philosophy (rational thinking). But power and wisdom in tribes and Islamic governments are limited to a triangle whose sides are formed by relatives and acquaintances, loot, and religious thought. Among these three, the Greece was more fanatic about their land, and Arab tribes respected supporting relatives." He refers to this point that although the emergence of Islam caused some changes in the sides of the tribes, it couldn't eliminate the mentality of Arab tribes entirely so that it survived even after Islam. Thus Farahi's analysis of the features of power in Islamic civilization is quite in opposition to feudalism in the West. Like many other monotheistic religions, Islam advocated equality of all Muslims and it was quite natural the Muslim Arabs, who were still in elementary levels of a new civilization and couldn't comprehend the principle of labor division and specialization of tasks entirely, accepted this Islamic order completely and thus began to conflict with Iranian aristocrats and noble families. Moreover, Arabs lacked feudal ideology and they didn't consider land as a source of wealth and on the other hand the annihilation of these classes would pave the way for Iran domination. Saint Christian who believed that aristocrat's

weakness resulted in decline of Iran wrote: "The reason of the decline of Iran's nation was the principles of equality of people and classes and lack of a preacher among people that happened after the emergence of Islam in Iran. The followers of Quran could do what Mazdakian couldn't. Aristocrats gradually disappeared and their features and attributes also vanished. West Asia domination by Iran was based on very ancient political traditions which only aristocrats and clergymen knew." Saint Christian believed that even though the trunk of Iran civilization tree was still standing with the survival of the peasants, that is second rate lords, the second reason of Iran's decline was the attack of the Turk to Iran after Arabs because the peasants were killed and disappeared in this attack. Meanwhile, Aristocrats in Iran didn't just own economic power but they had all nice and superior features of Aryan race in gaining knowledge and culture and art which, according to Saint Christian, resulted in West Asia domination by Iran. That is why in Aryan thought the evil ruling begins whenever ordinary people come to power. "These people have experienced through the history that whenever inferiors, who lacked racial, blood, intellectual or innate nobility, become the leaders of them, they provide everything for the evil attack and the evils will rule Iran and people misery will begin again in Iran (Frye RN, 2000)". According to Tabatabaee one effect of this issue is that with the elimination of aristocratic families and the nobles, the chiefs of the tribes monopolized political powers and the servants got emirates so they weren't able to keep the political system and would lose their political power after at most two generations. Therefore with the elimination of powerful aristocrats and their absence in political scene of Iran, the governments were always radically despotic or extremely dissipated since this class kept the political balance during Ancient Persia era and prevented the government's slide towards the extremes. Another factor that led to the fall of aristocracy and feudalism in Iran was related to the law of inheritance which was taken from the religious laws of Islam. It was mentioned that Lambton in his book "Owner and Farmer" considered this factor very effective and important in the fall of aristocratic system because after a few generations, feudal lands were broken into small pieces and this led to the destruction of feudalism (Reynolds, Susan. 1994). On the other hand, the formation of despotic systems in Islamic countries prevented the formation of rational legal systems. Max Weber emphasized that only the West has a single rational legal system while Asian legal systems were despotic and arbitrary. In societies with ideology of feudalism and strong hierarchical settings, each person is given a special task and duty



and nobody has the right to interfere in other's affairs. Meanwhile addressing some jobs or affairs was beneath the king's and or aristocrats' dignity. A part of Feudal ideology of Ancient Persia was reflected in Zoroastrianism. As mentioned earlier, since its emergence this religion was the religion of the farmers who were fighting with invaders who had tribal lifestyles. That is why Zoroastrianism is not in favor of trade and business. Therefore the first class and group who tended to Mani religion were businessmen because this religion had a favorable opinion to trade and business and on the contrary was against farming and ranching (Frye RN, 2000).

## 2. Discussion

Unlike the theories which were established under the influence of modernity era in 19<sup>th</sup> century and considered the same stages in the development of human society and history and which were repeated again in 1950s and 1960s, this research somehow came to the conclusion that the history of each country has its own special features which cannot be generalized to other countries. This discussion was raised by the founders of historical sociology such as Montesquieu and Alexi Duetocoil and was approved of by a group of Marxist intellectuals such as Barrington Moore, Skotchdopole, and pier Anderson, who were known as history oriented Marxists. According to these movements, in order to know a society you should refer to the history of that society because there aren't any common patterns to be generalized to the history of all countries. Therefore it is concluded that each society has its own particular history and the institutions, conflicts and political trends in each society are the results of evolution and changes that occur in the history of that community. In this research it was shown that the history of Iran cannot be explained by general models and theories. The history of Iran can neither be analyzed by the logic of feudalism which was raised by Marxists nor can be entirely explained by Karl Marx and Engels' theory of Oriental despotism and Asiatic mode of production. The history of ancient Persia which is the peak of culture and civilization of its people can be explained by the logic of feudalism while the history of Iran after the attack of Muslim Arabs can be analyzed by the theory of Oriental despotism and mode of production. Of course this historical process

continued until the constitutional revolution in Iran in 1906 and since then other issues are discussed.

## Acknowledgements:

Author is grateful to Department of Political Science, Zahedan branch, Islamic Azad University for financial support to carry out this work.

## Corresponding Author:

Zia Khazaei  
Department of Political Science, Zahedan branch,  
Islamic Azad University, Zahedan, Iran  
E-mail: khazaeiZia2@gmail.com

## References

1. Bill James A. 1963. The Social and Economic Foundations of Power in Contemporary Iran. *Middle East Journal*. Vol. 17, No. 4 (autumn,), pp. 400-418.
2. Brown, Elizabeth. 1974. 'the Tyranny of a Construct: Feudalism and Historians of Medieval Europe', *American Historical Review*, 79 (), pp. 1063-8.
3. Christensen, a (1971). "Sassanid Persia", in Cook, S. A., *the Cambridge Ancient History*, XII: The Imperial Crisis and Recovery (A.D. 193-324), Cambridge: Cambridge University Press, ISBN 0521044944.
4. Elton L Daniel,. (2001), *the History of Iran*, Westport, Connecticut: Greenwood Press, ISBN 978-0-313-30731-7.
5. Farhad Nomani. 1977. Notes on the Economic Obligations of Peasants in Iran, 300-1600 A.D. *Iranian Studies* Vol. 10, No. 1/2 (Winter - Spring,), pp. 62-83.
6. Frye RN, 2000. *the Golden Age of Persia*, Phoenix Press, p. 234.
7. James Denham-Steuart (1767). *An Inquiry into the Principles of Political Economy* vol1, vol2, vol3.
8. Poly, Jean-Pierre and Bournazel, Eric. 1991, *The Feudal Transformation, 900-1200.*, Tr. Caroline Higgitt. New York and London: Holmes and Meier.
9. Reynolds, Susan. 1994. *Fiefs and Vassals: The Medieval Evidence Reinterpreted.* Oxford: Oxford University Press.

9/17/2012

## The Economic Analysis and Evaluation of the Investment projects with special References to the fuzzy Approach

Ali Flahati <sup>1</sup>, Rahman Mirzaeian <sup>2</sup>

<sup>1</sup>associate professor, department of economics at Razi University

E-mail: [aliflahati@yahoo.com](mailto:aliflahati@yahoo.com)

<sup>2</sup>Department of economics, payam Noor University, po box 19395-3697 Tehran, Iran.

E-mail: [economistilam@yahoo.com](mailto:economistilam@yahoo.com)

**Abstract:** In evaluating the economic projects by using the classical methods, the exact amounts are used. But, according to the fact that the financial exchanges/cash flows and the rate of the projects' profit are not clearly stated, the results of such evaluations won't be a real one. Thus, the alternative method to do such evaluations has been stated to be fuzzy sums/numbers. In other words, instead of using on exact number, a triangular fuzzy number can be used. Such numbers are capable of showing an exact number in three different statuses: The smallest possible value, the most value. The net present value (NPV) techniques, the yearly monotonous value, and the relativity of the expenses to our profit have been processed and developed by the use of the fuzzy approach. The final results- instead of being the exact numbers- will be the fuzzy numbers which will enable the decision makers to attain a broad and wider insight about the probable outputs. Because the results are shown in fuzzy numbers, comparing the different projects won't be done in classical ways. The ranking method, which will be introduced in this essay, will compare different projects in their fuzzy status and will also help the decision makers to choose the best project.

[Ali Flahati, Rahman Mirzaeian. **The Economic Analysis and Evaluation of the Investment projects with special References to the fuzzy Approach.** *Life Sci J* 2012; 9(3):2691-2695] (ISSN: 1097-8135).

<http://www.lifesciencesite.com>. 392

**Keywords:** The economy of engineering, Decision making, Fuzzy sums, Language variable, Fuzzy Logic.

### 1. Introduction

The economic analysis of a project includes the techniques of recognition and comparing and choosing the best choice- among other choices- according to the economic conditions. Using and applying such analysis would be of great importance because our profits or losses are the direct. Consequences of the choices made according to the analysis. It is worth mentioning that because a lot of economic analysis will be used in the future decision making and in acting upon future events, therefore, the most important part in every economic analysis would be about the quantities related to the future.

#### 1.1. Statement of the problem:

Today, the economic techniques of analysis are of great significant in every organizational decision making. Managers-with the help of such. Analysis analysis- should identify the most preferable/profitable project. In other words, in analyzing all investment projects. The followings should be considered:

I.O of all the investment projects- considering the present limitations –should be identified and the necessary data should also be collected.

II. O of in formations should be analyzed and the most economic project must also be identified.

#### 2.1. The Necessity of the Research

In the common techniques of the economy of engineering, it is supposed that the parameters are

clear and exact. Although, the sensitivity analysis studies the changes in the parameters. There exists a presupposed assumption about the parameters' certainty and exactness. Here, by considering the fact that in – every decision, there is always some uncertain ties/vagueness; the economic researches will be discussed in the light of these uncertainties. For instance, it has been assumed that the primary information's for every project are constant/fixed (eg. The yearly income of 100/000), but the projects in the real world are not always containing the fixed/an changed information's. Changes and transformations are the unknown factors in the almost every managerial and engineering activity. The following examples can be stated:

I. Human resources are becoming more and more experienced every day.

II. By the process of time the materials usefulness will change, i.e. a change in their use will occur.

III. The machineries- high would be similar at the first look- appear to possess different capabilities.

Political and economical factors are also effective in the transformation of the future parameters. Although, identifying the changes is not a difficult task, their application in economic analysis would be a problematic one. By considering the uncertainties on the way, it is so hard to gain the exact information necessary for the evaluation of a project.

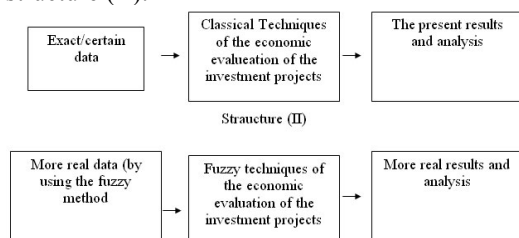
Thus, the results won't be so much acceptable. In other words, when there exists uncertainties in the economic evaluation of a project, the present methods will study them in a way that they contain exact/clear/certain information. According to what has been stated, the measurement of the amount of the basic variables is one of the issues in analyzing the investment projects. In most cases, the evaluation of the numeric amounts of such variables depends on the researcher's point of view: they are subjective. In such cases, the fuzzy logic has the capability to help the decision makers by noticing the applying language variables. In fact when a decision maker faces with statement such as, "around 30 years", "almost between 36.000 and 40.000", "nearly 9.000", the fuzzy logic can play an important role in such circumstances.

### 3.1. Research's Aims

The aim of this study is to use the capabilities of the fuzzy logic in providing a space for the evaluation of the investment projects in uncertain situations. In other words, by mixing the fuzzy concepts with the economic evaluations' techniques, the study aims at finding and bringing an approach to put together and blend science and experience. In most cases, the scholars' judgments about the application of the false information will produce better results, a point which is ignored by the classical techniques of the projects' economic evaluations. Moreover, the economic evaluation at the project considers only quantitative factors and forgets about the qualitative feature (eg. Political, cultural, etc.).

#### 1.3.1. The Research's Theoretical Framework

A variable which is of great importance in this research is the dependent variable or the results of the economic analysis of the investment projects. Independent variables are the primary data (inputs) of the investment projects: variables such as the primary expenses, fixed yearly expenses, the capital return rate, etc. The techniques of the economic evaluation of the projects are considered as mediator variables. According to what have been stated, the study's aim is to go beyond the structure (I) and arrive at the structure (II):



## 4. 1.The Research's Field of study

A. subject of study: this research aims at evaluating investment projects when the air is filled with uncertainty.

B. situational: The instructions presented in this research can be used in economy, banking, etc.

### 1.4.1. The Economic Evaluation of the project

The economic comparison between different projects. Is the most significant decision for every Manager? A manager, by choosing one of the economy of engineering techniques and its application, will present the most profitable project (Kahraman, C., Ruan, D., Tolga, E.(2002)).

Net present value method: it is one of the most important techniques of the economy of engineering, and is considered as a base. For other techniques, calculating the present value of a financial interaction is to change the future value of all the income and payment into the present value. In the net present value for a project is less than zero ( $NPV \leq 0$ ), that project would be regarded as an unprofitable/uneconomical one.  $NPV < 0$  show the fact that the present expenses are greater than the present income. But, if the  $NPV \geq 0$  is greater than or equals zero, that project would be an economical one. A project which has got more net present value is more economical.

Example I: comparing two projects (A,B) by using the present value method %15.

**Table 1:** Data

Table I, Data

Primary expenses	A	B
	2500	3500
Yearly expences	900	700
Relinquishing value	200	350
The useful life	5	5

$$PVA=2500+900 (P/A,10\%,5)-200 (P/F,10\%,5)=5788$$

$$PVB=3500+700(P/A, 10\%,5)-350(P/F,10\%,5)=5936$$

The A would be selected, because its present value of expenses is less than B ( $PVA < PVB$ ).

### 5.1. Fuzzy Approach

In fuzzy logic, the certain/an changed concepts of black and white are replaced by a gray color in which black and white are blended: no certainty can attain voice. In fuzzy logic one can use statements and modifiers such as: "It's almost right", "It's almost impossible", "scarcely", etc.

In this way, the fuzzy logic uses a flexible system of language use (Zimmermann, H.J (1996)). Fuzzy Numbers LR (left and Right).

Definition: The fuzzy number (M) is one of LR, if a function, e.g. L (for left) and R (for right), and scalar numbers ( $\alpha, \beta > 0$ ) are above zero

$$\mu_{\tilde{M}}(x) = \begin{cases} L\left(\frac{m-x}{\alpha}\right) & x \leq m \\ R\left(\frac{x-m}{\beta}\right) & x > m \end{cases}$$

In this way, m is a real number and is equal with the average of  $\tilde{M}$ .  $\alpha$ , and  $\beta$  are left and right span.

$\tilde{M}$  Is shown as (m,  $\alpha$ ,  $\beta$ ) LR (Zimmermann, H.J (1996)). The functions of LR have the following features:

1. R and L are reductive functions:  $\mathbb{R}^+ \rightarrow [0,1]$
2.  $L(0) = R(0) = 1$
3.  $L(x) < 1, R(x) > 0 \quad \forall x > 0$
4.  $L(x) > 0, R(x) < 1 \quad \forall x < 1$
5.  $L(1) = R(1) = 0$

Definition: The triangular fuzzy number

$\tilde{M} = (\alpha_1, \alpha_2, \alpha_3)$  and is shown as follow (Zimmermann, H.J (1996)).

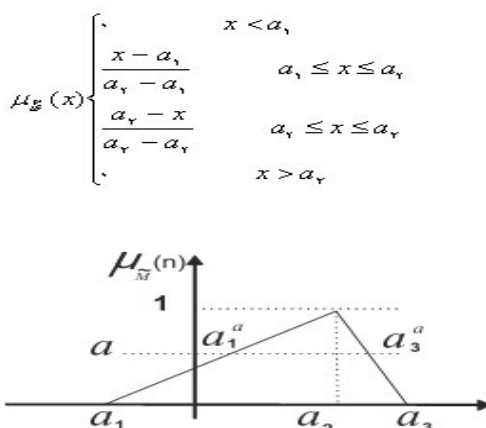


Figure 1: A triangular fuzzy number

### 6.1. The relationship between classical Economic Evaluation and the fuzzy Theory

The classical analysis of the economy of engineering is useful only if the available data be exact /certain. But, in the real world, the decision makers are faced with data which are uncertain/vague, g. high risk, low profit, etc. In other words, the uncertainties ahead of us need alternative

methods in which the human experience can be transformed into the mathematic language. One of the basic problems would be the measurement of the key variables of the analysis. In most cases, the evaluation of numeric variables is closely under the impression the individual's judgments of the analyzer. To put it in another way, because the decision makers are obliged to make decisions without enough knowledge about the problem, they are willing to present their evaluations according to the personal knowledge and experience. The statements like, "around 30 gears, almost between 36.000 and 40.000" and "nearly 9%" are examples of such a problem. Another point to be discussed here is the question of how such uncertain/vague statements can be used in economic analysis. The fuzzy logic and the theory of fuzzy sums (fuzzy numbers) play a significant role here. In this way, the fuzzy susytem can make the basic input about the income expences can be shown – instead of an exact number- in form of a triangular fuzzy number. A trainglar fuzzy number which can be shown as  $(x=x_1, x_2, x_3)$  states a fuzzy event in which  $x_1$  is the smallest possible value,  $x_3$ ;the largest possible value, and  $x_2$  can be regarded as the most promising value. The most promising value. The results of evaluations made by fuzzy numbers are also shown by fuzzy numbers. This makes the analyzers to have wider views about the probable aoutputs (Liang, 1995m 79).

### 7.1. The research's methodology

In this study, an approach which includes a way of mixing the scholars ideas will be presented. This approach would be used in forecasting future events when the situation is filled with uncertainty. By the help of this method, the fuzzy data which are the inputs will be obtained. Then, by adding fuzzy sums with the classical techniques of economical evaluations, the fuzzy technique of economical evaluation of investment projects will be introduced. Section one: making the project's input, fuzzy the method of fuzzy Delphi is the generalization of the classical method of long- term forecasting.

If it is known in managerial science as Delphi method. The basics of Delphi method are as follow:

1. Scholars are asked to separately give their opinions about a subject, e.g. the yearly expense of an investment project. It is also probable to ask them to forecast the overall situation of the market economy, etc.
2. Then the information are collected and analyzed, and after that the results will be returned to those scholars.
3. Scholars will study the results and give new premonitions.

4. This process is repeated again and again in order to reach a homogenized solution.

The decisions which would be made according to the scholars' analysis are abstract and imaginative. Thus, it is more acceptable to describe the information in terms of the fuzzy numbers. Triangular fuzzy numbers consist of the smallest, the largest and the most promising value.

According to what has been stated, fuzzy Delphi includes the following stages:

I. scholars (E<sub>i</sub>, i=1, 2, n) are asked to state clarify their opinions about a project in terms of the smallest ( $a_1^i$ ), the most promising ( $a_m^i$ ), and the largest possible value ( $a_2^i$ ). The information given by the scholars are changed in fuzzy numbers by the scholars (E<sub>i</sub>):

$$A_i = (a_1^i, a_m^i, a_2^i), i=1, 2, \dots, n$$

II. The average of A<sub>i</sub>s ( $A_{ave}(m_1, m_m, m_2)$ ) will be calculated, then the deviation A<sub>i</sub> from A<sub>ave</sub> would be determined, they are shown in a triangular number. Finally, the deviation between a ave - A<sub>i</sub> will be reported to the scholars in order to be tested.

III. Each scholar (E<sub>i</sub>) gives a new triangular number  $B_i = (b_1^i, b_m^i, b_2^i)$

When the second stage starts, this process will be repeated. The triangular average (B<sub>m</sub>) is calculated, but this time  $a_1^i, a_m^i, a_2^i$  are replaced by  $b_1^i, b_m^i, b_2^i$ . If necessary, the new triangular numbers C<sub>i</sub>=( $c_1^i, c_m^i, c_2^i$ ) will be produced and the average will be calculated. This process will be repeated again and again.

TV, If new discoveries reveal important and unnoticed information, forecasting will be tested according to the same process (stages 1 to 3). Fuzzy Delphi is one way among others to mix different ideas.

**8.1. Sensitivity Analysis**

Before applying the results attained from the above calculations, in analyzing cash flow, we have to notice the fact that the boundaries of the final fuzzy number is a base upon which the decisions are made. In other words, if this boundary is small and not so wide, choosing the preferable item will be an easy task. But, if the boundary is wide and large, the final decision in choosing the preferable case would generate some difficulties. The aim of sensitivity analysis is to determine the factors which will mostly affect the final fuzzy number. In other words, sensitivity analysis is one of the ways of reducing the final fuzzy number's boundary. After the sensitivity analysis, the decision maker will attain and collect

information about the sensitivity rate of the result of the problem. This information will help him/her to give a more accurate definition of the data.

**9.1. Fuzzy Net present value**

In order to reach a formula of fuzzy net present value the following concepts should be defined: Net present value (NPR), left, the smallest possible value (L); mean, the most promising value (M); right, the largest possible value; cash flow (F), Interest rate (i), Time (n, t).

It is worth mentioning that in fuzzy investment projects one is just allowed to use (SPPWF), Present value.

This present value will determine the amount of data (F) after (n) years and rate of (i) percent.  $(P/F, i\%, n) = \frac{1}{(1+i)^n}$  (14)

The final formula of fuzzy net present value (FNPR) is derived from methods of cash flow reduction and fuzzy mathematics:

$$NPV_L = F_0^L + \sum_{t=1}^n F_t^L \begin{cases} \prod_{i=1}^n (P/F, i_t^L \%, 1) & F_t^L < 0 \\ \prod_{i=1}^n (P/F, i_t^R \%, 1) & F_t^L > 0 \end{cases} \quad (2.4)$$

$$NPV_M = F_0^M + \sum_{t=1}^n F_t^M \prod_{i=1}^n (P/F, i_t^M \%, 1) \quad (3.4)$$

$$NPV_R = F_0^R + \sum_{t=1}^n F_t^R \begin{cases} \prod_{i=1}^n (P/F, i_t^L \%, 1) & F_t^R > 0 \\ \prod_{i=1}^n (P/F, i_t^R \%, 1) & F_t^R < 0 \end{cases} \quad (4.4)$$

$$FNPV = (NPV_L, NPV_M, NPV_R) \quad (5.4)$$

If you want to compare the (FNPV) for several projects, we can use the method of arranging the fuzzy member's which will be discussed below. Another point to be mentioned here is the calculation of the difference between two fuzzy values (FNPV), in order to do that one can use the formulas below: The distance between two triangular fuzzy numbers of  $\tilde{M} = (a_L, a_M, a_R)$  and  $\tilde{N} = (b_L, b_M, b_R)$  would be calculated as:

$$S(\tilde{M}, \tilde{N}) = \frac{(a_L + 2a_M + a_R) - (b_L + 2b_M + b_R)}{4} \quad (6.4)$$

$S(\tilde{M}, \tilde{N})$  Is the algebraic distance between  $\tilde{N}$  and  $\tilde{M}$  witch can be negative, positive or zero.

**10.1. The Order of Fuzzy Number**

In discussing fuzzy numbers, their arrangement and order is one of the key issues. There are different ways of arranging fuzzy numbers, here; one of them will be discussed. In this method, three

standards have been presented. These standards must be used carefully one after the other. (Lee. S. M., Lin. K. L., Gupta. S (1994).

I. for Every triangular number  $\tilde{M} = (a_L, a_M, a_R)$ , the following formula must be used:

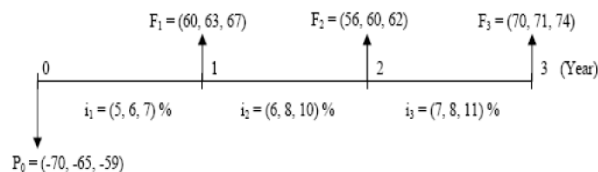
$$S(\tilde{M}, O) = \frac{a_L + 2a_M + a_R}{4} \quad (7.4)$$

Category, you can arrange them by applying the standard. In this way the most promising value of each one is compared with others.

III. Still, there may be some numbers belonging to the same category. By using the domain criteria, we can reach the linear order of the fuzzy numbers. The larger the difference between the smallest and the largest possible value in each triangular number gives it a height rank /position among others.

### 11.1. Numeric Example

Consider a 3 years investment project. Cash flow and preferable rate have been shown in the below figure. Net present value of this project will be calculated as:



**Figure2:** Cash flow and preferable rate

By using the classical techniques, net present value is 104. But, by using fuzzy formulas the triangular fuzzy number will be (87,104,123).

## 2. Discussions

In the first section, a technique for making the uncertain data capable of becoming fuzzy has been thoroughly discussed. Data such as the primary capital, return rate, capital, etc. will be considered in evaluating the projects.

In the second part, the formula for calculating the fuzzy net present value was presented. This formula has the capability to take the fuzzy data of the investment projects and give the results in the form of a fuzzy number. In this formula, the most

promising value is exactly the same as the result of the classical evaluation. Then, for calculating the largest possible value, some of the primary was use. The same method can be used for identifying the smallest possible value.

In the third part, a method for arranging the fuzzy numbers- which would be used in choosing the best project-was introduced.

In this research, the application of the triangular fuzzy numbers presents a good approach to the cash flows in the economic analysis of the projects

By considering the analysis, one can surmise that the given methods of fuzzy approach are more fruitful /desirable. Using this approach helps the decision makers to have more information about the possible results. The results reached by fuzzy system are more reliable even if the primary data (input) change. Finally, find in designs of this research can help solving the problems of evaluating the investment projects, such as the uncertainties around the impute data and also lack of exact information.

### .Acknowledgements:

Authors are grateful to Department of economics, payam Noor University for financial support to carry out this work.

### Corresponding Author:

Rahman Mirzaeian

Department of economics, payam Noor University, PO Box 19395-3697 Tehran, Iran.

E-mail: [economistilam@yahoo.com](mailto:economistilam@yahoo.com)

### References

1. Kahraman, C., Ruan, D., Tolga, E.(2002).: Capital budgeting techniques using discounted fuzzy versus probabilistic cash flows. Inf Sci 142, 57-76.
2. Lee. S. M., Lin. K. L., Gupta. S (1994)," Economic Decision Making Using Fuzzy Numbers", Florida International University.
3. Zimmermann, H.J (1996), 3rd Ed; Fuzzy Set Theory, Boston/Dordrecht/London, Kluwer academic publisher.

9/17/2012

## Use of the *cdt* gene specific PCR in determining virulence properties of *Campylobacter jejuni* isolated from chicken meat samples obtained in some supermarkets in Mafikeng, NWP, South Africa

Masego Montwedi and Collins Njie Ateba \*

Department of Biological Sciences, School of Environmental and Health Sciences, Faculty of Agriculture Science and Technology, North-West University – Mafikeng Campus, P. Bag X2046 Mmabatho 2735, South Africa. [atebacollins1@hotmail.com](mailto:atebacollins1@hotmail.com)

**Abstract:** *Campylobacter* species are implicated as the most common cause of gastroenteritis worldwide and this usually results from the consumption of contaminated water or food. Sporadic cases and /or outbreaks of infections cause by *Campylobacter* species are frequently reported in countries that have more advanced public health facilities. However, in South Africa, chicken processing industries do not perform routine screening for this pathogen. The aim of this study was to isolate *Campylobacter* species from chicken meat samples and to determine their virulent gene determinants using species specific PCR. Chicken samples were bought from some supermarkets, properly labeled and transported on ice to the laboratory for analysis. Samples were analyzed for characteristics of *Campylobacter* using preliminary (Gram staining, oxidase test and catalase test) and confirmatory (API *Campy*) biochemical tests. A total number of seventy (70) preliminary isolates were subjected to the above mentioned tests. The morphology of the species was observed as curved spiral rods that were gram negative. Sixty six (66) isolates were positive for the oxidase test and fifty four (54) isolates for the catalase test. When the confirmatory (API *Campy*) test was used, 62.5% of the isolates were positive for *Campylobacter jejuni* and the rest were identified as *C. lari* and *C. coli*. The subsequent positive isolates were amplified by specific PCR analysis to authenticate identification. The virulent gene determinants *cdtA*, *cdtB*, and *cdtC* were identified using specific PCR and their presence was established. The results obtained in this study indicate that the chicken meat that was tested was contaminated with *C. jejuni*.

[Montwedi MG, Ateba CN. Use of the *cdt* gene specific PCR in determining virulence properties of *Campylobacter jejuni* isolated from chicken meat samples obtained in some supermarkets in Mafikeng, NWP, South Africa. *Life Sci J* 2012;9(3):2696-2701] (ISSN:1097-8135). <http://www.lifesciencesite.com>. 393

**Keywords:** *Campylobacter jejuni*, gastroenteritis, chicken meat, cytolethal distending toxin (CDT), PCR analysis

### 1. Introduction

*Campylobacter* species are small, curved, motile, microaerophilic gram-negative spiral rods with individual cells range from 0.2-0.9  $\mu\text{m}$  in width and 0.5-5.0  $\mu\text{m}$  in length (Ang et al., 2011). They exhibit rapid, darting motility in corkscrew fashion using a single flagellum (Ang et al., 2011). Although there are many species within the genus, *C. jejuni* and *C. coli* are the most frequently isolated from humans, animals, water and environmental sources (Allos, 2001).

*Campylobacter* species have been isolated from a wide variety of domestic animals that include pets, cattle, swine, and sheep (Saito et al., 2006; Krutkiewicz and Klimuszko, 2010). However, poultry are known to be the most common source *Campylobacter* and therefore the consumption of improperly cooked poultry meat is the most common risk factor for human infections (Grant et al., 1993; Steinbruecker et al., 2001; Lubber et al., 2006; Andersen et al., 2006; Zorman et al., 2006; Han et al., 2007; Aquino et al., 2010; EFSA, 2010; Behringer et al., 2011). *Campylobacter* species cause diseases in humans through the production of toxins and/or invasions and these virulence determinants contribute

to survival and establishment of disease in susceptible hosts (Bhavsar and Kapadnis, 2007). Infections caused by *Campylobacter* species include gastroenteritis that may be self limiting (Allos, 2001). However, in some patients the disease may progress to Guillain-Barre Syndrome, a neurological disease that most often results in death (Caporale et al., 2006).

A number of toxins are produced by the different *Campylobacter* species and *C. jejuni* produces the cytolethal distending toxin (CDT) (Lee et al., 2003). CDT causes direct damage on the DNA of the host cell leading to damage. The affected cells arrest in G1 or G2 phases and eventually die. The CDT gene cluster consists of three protein subunits that include the *cdtA*, *cdtB*, and *cdtC*. Although very little is known about the functions of the *cdtA* and *cdtC* gene fragments, the *cdtB* has recently identified to have nuclease activities (Lee et al., 2003). Beside these virulence determinants, the presence of flagella in pathogenic *Campylobacter* species has been found to enhance attachment, internalization and translocation of epithelial cells of GIT in infected individual and thus contribute to their pathogenicity (Grant et al., 1993; Müller et al., 2011). However, the

ability to resist oxidative stress, toxin production, and invasive properties significantly enhances the survival of *Campylobacter* species in the host and these increase the chances of developing disease (Bhavsar and Kapadnis, 2007).

Several studies have been conducted to determine relationship of *Campylobacter* species from different sources and therefore assess their similarities based on their antibiotic resistance profiles, *flaA*-RFLP, MLST, PFGE and REP-PCR profiles (Luber et al., 2006; Behringer et al., 2011). Close similarities in the antibiotic resistant profiles and genetic patterns between strains obtained from humans and poultry indicating that chicken meat could be a potential source for transmitting *Campylobacter* species to humans (Luber et al., 2006; Behringer et al., 2011). Despite the problems that *Campylobacter* species pose to consumers even in countries with more advanced public health and health care facilities (Andersen et al., 2006; Zorman et al., 2006; Han et al., 2007; Aquino et al., 2010), poultry processing industries do not screen for these pathogens in both live birds and the finished products in South Africa. It is therefore suspected that these pathogens may be transmitted to humans if chicken meat is improperly cooked and consumed. Moreover, in the North West province of South Africa, only one study has been documented that evaluates the occurrence of this pathogen in chicken meat (Mabote et al., 2011). This study was therefore aimed at providing information of both the level of contamination with *Campylobacter* species in chicken meat samples from supermarkets in the Mafikeng and their virulent gene determinants.

## 2. Materials and methods

### 2.1 Sampling site

A total of 10 packets of fresh chicken meat samples were bought at supermarkets and butcheries in around Mafikeng.

### 2.2 Sample collection

The chicken meat samples were properly labeled and transported on ice to the laboratory for analysis. Upon arrival in the laboratory, the samples were analyzed for the presence of *Campylobacter* species within 24 hours.

### 2.3 Analysis of the samples

Approximately 2g of each chicken meat sample was washed in 5ml of 2% peptone water (Biolab, S.A). Ten fold serial dilutions were prepared and the aliquots of 100µl from each dilution was spread-plated on Brain Heart Infusion (BHI) agar that was supplemented with *Campylobacter* selective supplement (Vacomycin=10mg/L; Polymyxin

B=0.25mg; Trimithoprim= 5.0 mg/L) and 5% ox-blood. The selective supplement was obtained from Merck, Germany and supplied by Merck, South Africa. The plates were incubated under micro-aerophilic conditions at 37°C in 10% CO<sub>2</sub> for 24 to 72 hours. After incubation presumptive *Campylobacter* isolates that were grey in colour were sub-cultured on to fresh BHI agar plates and the plates were incubated as mentioned above. Pure colonies were stored at room temperature until they were identified using preliminary and confirmatory biochemical tests.

## 2.4 Identification of presumptive *Campylobacter* species

The presumptive *Campylobacter* species were identified using the following criteria:

### 2.4.1 Gram staining

Isolates were gram stained using the standard methods to determine the morphology of the cells (Cruikshank et al., 1975). Isolates that were Gram negative and spiral in shape were retained for identification using preliminary tests.

## 2.5 Preliminary Biochemical Tests

### 2.5.1 Oxidase test

The oxidase test was performed using the oxidase test reagent obtained from Pro-Lab Diagnostics- United Kingdom as indicated in the manufacturer's protocol. Test results were recorded as positive upon the observation of a colour change and negative if no colour was produced.

### 2.5.2 Catalase test

This test was used to determine the presence of the catalase enzymes that degrade toxic hydrogen peroxide in cells containing the cytochrome oxidase system.

## 2.6 Confirmatory Biochemical Test

### 2.6.1 Analytic Profile Index Campy (API Campy)

The API Campy test was performed according to instructions from the manufacturer (BioMérieux, Marcy l'Etoile, France). The indices generated for the different isolates were used to determine their identities with the API web software.

## 2.6.2. Confirmatory identification of *Campylobacter jejuni* using PCR

### 2.6.2.1 DNA extraction

Pure isolates from the Brain Heart Infusion agar were inoculated into 10ml of nutrient broth and incubated aerobically at 37°C for 24 hours in a shaking incubator to enhance bacterial growth. DNA



was extracted using the alkaline lysis method with certain modifications (Sambrook et al., 1989).

All isolates were screened for identification of *C. jejuni* using *ceuE* specific primers. The primer sequences of the oligonucleotides used are shown in Table 1. All PCR amplifications were performed using DNA thermal cycler (model-PTC-220 DYAD™ DNA ENGINE). The reactions were prepared in 25µl volumes which were made up of 10µg/µl of the template DNA, 50pmol of each oligonucleotide primer set, 1X PCR master mix and nuclease free water. All PCR reagents were obtained from Fermentas, USA but supplied by the Inqaba Biotec Ltd, Sunnyside South Africa. The cycling conditions included an initial DNA denaturation step at 95°C for 5 minutes; 30 cycles of denaturation step at 95°C for 30 seconds; primer annealing at 62°C for 1 minute and primer elongation 72°C for 30 seconds. The final elongation was carried out at 72°C for 10 minutes and PCR products were stored at 4°C.

**Table 1:** Oligonucleotide sequences of PCR primers that were used for the identification of *Campylobacter jejuni*

Primers	Sequence (5'→3')	Product size (bp)
JEJ1	CCTGCTACGGTCAAAGTTTGC	793
JEJ2	GATCTTTTTGTTTTGTGCTGC	

### 2.6.2.2 PCR for the detection of virulence genes in *C. jejuni* isolates

The virulence gene determinants in *C. jejuni* isolates were determined by specific PCR analysis using the primers that listed in Table 2. Cycling was performed using a DNA thermal cycler (model-PTC-220 DYAD™ DNA ENGINE) at an initial DNA denaturation step at 95°C for 5 minutes; 30 cycles of 95°C for 30 seconds; 60°C for 1 minute and 72°C for 30 seconds. The final elongation was carried out at 72°C for 10 minutes and products were stored at 4°C.

**Table 2:** Oligonucleotide sequences of PCR primers that were used for the detection of virulence genes in *Campylobacter jejuni* isolates

Target gene	Primers	Sequence (5'→3')	Product size (bp)
<i>cdtA</i>	DS-18	CCTTGTGATGCAAGCAATC	370
	DS-15	ACACTCCATTGCTTTCTG	
<i>cdtB</i>	<i>cdtB</i> -113	CAGAAAGCAAATGGAGTGT	620
	<i>cdtB</i> -713	AGCTAAAAGCGGTGGAGTAT	
<i>cdtC</i>	<i>cdtC</i> -192	CGATGAGTTAAAACAAAAGATA	182
	<i>cdtC</i> -351	TGGCATTATAGAAAATACAGTT	

### 2.6.3 Electrophoresis

The DNA extracted and PCR products were resolved by electrophoresis on a 1% (w/v) agarose gel at 80 volts for 3hours, using 1X TAE buffer (40Mm Tris, 1Mm EDTA and 20 mM glacial acetic

acid, pH 8.0). A 100bp DNA molecular weight marker (Fermentas, USA) was included in each gel. The gels were stained in 0.001 µg/ml of ethidium bromide for 15 minutes and the amplicons were visualized under UV light at 420nm wavelength (Sambrook et al., 1989). A gene Genius Bio Imaging System (Syngene, Synoptics; UK) was used to capture the images using Gene Snap (version 6.00.22) software. Gene Tools (version 3.07.01) software (Syngene, Synoptics; UK) was used to analyze the images in order to determine the relative sizes of the amplicons.

### 2.6.4 Control strain

*C. coli* (ATCC 43478) and *C. jejuni* (ATCC 33291) were used as negative and positive control strains, respectively, in all experiments.

## 3 Results

### 3.1 Detection of *Campylobacter* species using preliminary biochemical and API Campy tests

A total of 70 presumptive isolates identified based on colonial morphology on BHI agar were subjected to preliminary and confirmatory screening tests characteristic of *Campylobacter* species. Results for the different tests are as shown in Table 3. All the isolates were spiral rods. A large proportion of the isolates (54 out of 70) were catalase positive. Further, 66 out of 70 of these isolates were oxidase positive. *Campylobacter* species are both catalase and oxidase positive and these isolates satisfied the identification criterion for the genus. Based on the API Campy test, all the isolates were identified as *Campylobacter* species despite the results obtained for the catalase and oxidase tests. A large proportion of the isolates (61.4%) were identified as *C. jejuni* while *C. coli* and *C. lari* were obtained at proportions of 25.7% and 12.9%, respectively.

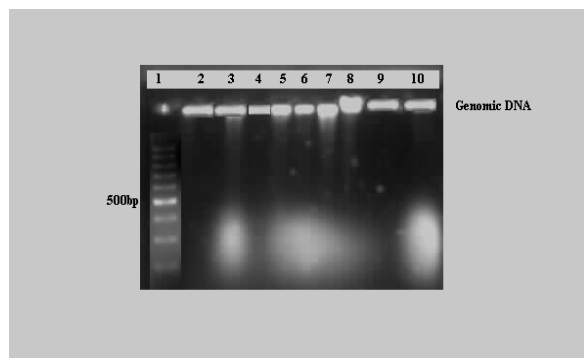
**Table 3:** Results of the biochemical tests and gram staining for identification of *Campylobacter* species

Gram staining	Catalase test		Oxidase test		API Campy		
	+	-	+	-	<i>C. coli</i>	<i>C. jejuni</i>	<i>C. lari</i>
Spiral rods	54	16	66	4	18	43	9

### 3.2 Confirmation of *Campylobacter* species using the Polymerase Chain Reaction (PCR) technique

#### 3.2.1 DNA extraction

A total of 70 *Campylobacter* isolates that had been presumptively identified using the API Campy test kit were screened by PCR for characters of *C. jejuni* using specific primers (Table 3). The makeup of these isolates included 18 *C. coli*, 43 *C. jejuni* and 9 *C. lari*. DNA extracted from these isolates is shown in Figure 1.



**Figure 1:** Lane 1= 100bp DNA marker; Lanes 2-10= DNA extracted from *Campylobacter* isolates from test isolates that were screened.

### 3.2.2 Proportion of *C. jejuni* isolates identified from chicken meat samples obtained from supermarket through PCR amplification of the *JEJ* gene fragments

The identities of *C. jejuni* isolates were investigated based on the presence of the *JEJ* gene fragments using specific PCR analysis. A total number of 70 isolates were screened and a large proportion (71.4%) was identified by PCR as *C. jejuni*. Results obtained from PCR typing indicated that all the isolates that were positively identified as *C. jejuni* using API Campy were also correctly confirmed by specific PCR analysis. However, a small proportion (28.6%) of the *C. jejuni* isolates were not correctly identified by API analysis. From these results it is therefore suggested that molecular methods are more reliable in the detection and classification of microbes in general and these pathogens in particular. Correct identification would facilitate management strategies and thus reduce human infections that result from the consumption of contaminated meat products.

### 3.2.3 Amplification of the virulent genes from confirmed *Campylobacter jejuni* isolates using specific PCR analysis

The *cdtA*, *cdtB* and *cdtC* virulent gene determinants were amplified from confirmed *C. jejuni* isolates by PCR analysis using specific primer sequences, with *C. coli* (ATCC 43478) and *C. jejuni* (ATCC 33291) serving as negative and positive controls, respectively. A total of 50 *C. jejuni* isolates were subjected to this screening method and the number of isolates that were positive for these genes are shown in Table 4.

**Table 4:** Number of *Campylobacter jejuni* that were positive for the *cdt* genes

Targeted specie	No. of virulence genes positive by specific PCR analysis		
	<i>cdtA</i>	<i>cdtB</i>	<i>cdtC</i>
<i>Campylobacter jejuni</i>			
NT = 50	18	43	9

## 4. Discussion

The primary aim of the study was to isolate *Campylobacter* species from chicken meat samples obtained from supermarkets in the Mafikeng area. Although numerous studies have been conducted in countries with more advanced health care systems, very little information exists on the prevalence of *Campylobacter* species in South Africa and Mafikeng in particular (Mabote et al., 2011). In the present study, all the samples were found positive for *Campylobacter* species. The species distribution indicated that *C. jejuni* was more frequently identified when compared to *C. coli* and *C. lari*. These findings are similar to those reported in other studies in which *C. jejuni* and *C. coli* are the species that are mostly isolated from food products such as chicken, eggs, milk and meat (Yu et al., 2001; Saito et al., 2005; Oyarzabal et al., 2007; Rantsiou et al., 2010; Mabote et al., 2011; González and Hämmänen, 2011; Kudirkienė et al., 2011). The results obtained in the present study indicated that chicken meat may serve as a potential source for the transmission of *Campylobacter* species to humans. Moreover, *Campylobacter* species are easily transmitted from live birds to humans who work in a broiler house (Shreeve et al., 2000). There is need to screen *Campylobacter* species in the area using genetic fingerprinting methods to facilitate an understanding of the potential transmission routes of this pathogen to human (Steinbruecker et al., 2001). This may reduce the incidence of *Campylobacter* associated infections in humans.

Another objective of the study was to screen positively identified *Campylobacter* species for the presence of the *cdt* virulence gene determinants. *Campylobacter* species cause diseases in humans that result from the ability to express certain virulent genes. The cytolethal distending toxin (CDT) is present in *Campylobacter* species (Johnson and Lior, 1988) and this toxin induces cell distension in different mammalian cell lines resulting in elongation, swelling, and eventually cell death (Whitehouse et al., 1998). Although the *cdt* cluster contains a number of specific gene determinants, in the present study only the *cdtA*, *cdtB*, and *cdtC* were detected. The *cdtA* and *cdtC* are necessary for binding to the host cell while the *cdtB* is the active moiety of the *cdt* ABC complex (Pickett and Whitehouse, 1999; Lara-Tejero and Galán, 2001). The *cdt* genes in *C. jejuni* are known to play a role in

the invasion and modulation of the immune response thereby contributing to the pathogenesis in host cells (Purdy et al., 2000). In chickens the *cdt* genes do not cause inflammation of the intestinal epithelium, while in humans CDT toxin induces the production of neutralizing antibodies which indicates that *C. jejuni* antigens are host-specific (Young et al., 2007). In the present study, all isolates possessed the *cdt* genes and these genes could cause disease in humans if the chicken meat products are consumed undercooked. Moreover, the impact of this pathogen is even more severe when infections are caused by multiple antibiotic resistant strains (Pratt and Korolik, 2005).

Isolation, identification and characterization of *C. jejuni* were carried out using both conventional microbiological and molecular methods, which included polymerase chain reaction (PCR). The results obtained reflected that contamination had occurred in the chicken meat products that were tested and indicated the presence of *Campylobacter* species. However, the contamination identified at retail points do not exclude that which occurred in the farms and the slaughter houses. Contamination during processing can be identified at the retail points or in the finished products (Alter et al., 2006; Kudirkienė et al., 2011). The results therefore indicate that meat products should be cooked properly at a minimum internal temperature of 73.9°C to prevent these pathogens from producing their virulent gene determinants and thus reduce the occurrence of diseases in humans. This recommendation was proposed by the United States Department of Agriculture – Food safety and inspection services.

Seventy (70) presumptive isolates were screened for characters of *Campylobacter* species using several conventional microbiological methods (Gram staining, oxidase test, catalase test and API Campy test). All the isolates were positively identified. However, *Campylobacter* specific PCR analysis revealed that although a large proportion (71.4%) of those isolates were *C. jejuni*, some of them were false positive results when conventional microbiology methods were employed. It is therefore suggested that to obtain accurate results when investigating the occurrence of pathogens in food and/or water samples, conventional microbiological methods must be used in combination with specific PCR analysis.

### 5. Conclusions

*Campylobacter jejuni* was isolated from the chicken meat samples that were bought from various supermarkets and butcheries in the Mafikeng area. Infections that are caused by *Campylobacter* species vary from diarrhoea to the more complicated neuropathological autoimmune diseases such as Guillain Barre Syndrome and Miller-Fisher

Syndrome that may lead to the death of the patient (Fry et al., 2000). These infections may be more severe in patients whose immune system is compromised and thus in a country like South Africa the importance of these studies cannot be over emphasized.

### Acknowledgement:

Authors are grateful to the Department of Biological Sciences, North West University-South Africa for financial support to carry out this work.

### Correspondence to:

Dr. C.N Ateba

Department of Biological Sciences, School of Environmental and Health Sciences, Faculty of Agriculture Science and Technology, North-West University – Mafikeng Campus, P. Bag X2046 Mmabatho 2735, South Africa.

Telephone: +27-78-334-4878

Emails: [atebacollins1@hotmail.com](mailto:atebacollins1@hotmail.com)

### References

1. Allos BM. (2001). *Campylobacter jejuni* Infections: Update on Emerging Issues and Trends. Clin. Infect. Dis. 32: 1201–1206.
2. Ang JY, Nachman S. (2011). Pediatric *Campylobacter* Infections. Medscape reference
3. Alter T, Bori A, Hamed A, Ellerbroek L, Fehlhaber K. (2006). Influence of inoculation levels and processing parameters on the survival of *Campylobacter jejuni* in German style fermented turkey sausages. Food Microbiol. 23(7): 701-707.
4. Andersen SR, Saadbye P, Shukri NM, Rosenquist H, Nielsen NL, Boel J. (2006). Antimicrobial resistance among *Campylobacter jejuni* isolated from raw poultry meat at retail level in Denmark. Int. J. Food Microbiol. 107(3): 250-255
5. Aquino MHC, Filgueiras ALL, Matos R, Santos KRN, Ferreira T, Ferreira MCS, Teixeira LM, Tibana A. (2010). Diversity of *Campylobacter jejuni* and *Campylobacter coli* Genotypes from Human and Animal Sources from Rio de Janeiro, Brazil. Res. Vet. Sci. 88(2): 214-217.
6. Behringer M, Miller WG, Oyarzabal OA. (2011). Typing of *Campylobacter jejuni* and *Campylobacter coli* isolated from live broilers and retail broiler meat by *flaA*-RFLP, MLST, PFGE and REP-PCR. Microbiol. Meth. 84(2): 194-201.
7. Bhavsar SP, Kapadnis BP. (2007). Virulence factors of *Campylobacter*. J. Microbiol. 3(2).
8. Caporale CM, Capasso M, Luciani M, Prencipe V, Creati B, Gandolfi P, De Angelis MV, Di-Muzio A, Caporale V, Uncini A. (2006). Experimental axonopathy induced by immunization with *Campylobacter jejuni* lipopolysaccharide from a patient with Guillain-Barré syndrome. Neuroimmunol. 174(1-2): 12-20.
9. Cruikshank R., Duguid J.P., Marmoin B.P., Swain R.H. (1975). Medical Microbiology. 12<sup>th</sup> Edition. New York: Longman Group Limited

10. Fry BN, Shi Feng, Yuen-Yuen C, Diane GN, Peter JC, Victoria K. (2000). The gale gene of *Campylobacter jejuni* is involved in lipopolysaccharide synthesis and virulence. *Infect. Immun.* 68: 2594-3601
11. **González M, Hänninen M. (2011). Reduction of *Campylobacter jejuni* counts on chicken meat treated with different seasonings. *Food Cont.* 22(11): 1785-178**
12. Grant CCR, Michael EK, Witold CJR, Lucy ST. (1993). Role of flagella in adherence, internalization and translocation of *Campylobacter jejuni* in non polarized and polarized epithelial cell cultures. *Infect. Immun.* 61: 1764-1771
13. Han K, Sik-Jang S, Choo E, Heu S, Ryu S. (2007). Prevalence, genetic diversity, and antibiotic resistance patterns of *Campylobacter jejuni* from retail raw chickens in Korea. *Int. J. Food Microbiol.* 114(28): 50-59.
14. Johnson WM, Lior H. (1988). A new heat-labile cytolethal distending toxin (CLDT) produced by *Campylobacter* spp. *Microb. Pathogen.* 4: 115-126.
15. Kelly DJ. (2001). The physiology and metabolism of *Campylobacter jejuni* and *Helicobacter pylori*. *Appl. Microbiol.* 90: 16-24.
16. Krutkiewicz A, Klimuszko D. (2010). Genotyping and PCR detection of potential virulence genes in *Campylobacter jejuni* and *Campylobacter coli* isolates from different sources in Poland. *Folia Microbiol.* 55 (2): 167-175.
17. Kudirkienė E, Bunevičienė J, Brøndsted L, Ingmer H, Olsen JE, Malakauskas M. (2011). Evidence of broiler meat contamination with post-disinfection strains of *Campylobacter jejuni* from slaughterhouse. *Int. J. Food Microbiol.* 145(1): S116-S120.
18. Lara-Tejero M, Galán JE. (2001). *CdtA*, *CdtB*, and *CdtC* form a tripartite complex that is required for cytolethal distending toxin activity. *Infect. Immun.* 69: 4358-4365.
19. Lee RB, Hassane DC, Cottle DL, Pickett CL. (2003). Interactions of *Campylobacter jejuni* Cytolethal Distending Toxin Subunits *CdtA* and *CdtC* with HeLa Cells. *Infect. Immune.* 71: 4883-4890
20. Luber P, Brynestad S, Topsch D, Scherer K, Bartelt E. (2006). Quantification of *Campylobacter* species cross-contamination during handling of contaminated fresh chicken parts in kitchens. *Appl. Environ. Microbiol.* 72: 66-70.
21. Mabote IK, Mbewe M, Ateba CN. (2011). Prevalence of *Campylobacter* in fresh chicken meat and milk obtained from markets in the North West Province, South Africa. *Human Ecol.* 36(1): 23-28
22. Müller W, Böhlend C, Methner U. (2011). Detection and genotypic differentiation of *Campylobacter jejuni* and *Campylobacter coli* strains from laying hens by multiplex PCR and *fla*-typing. *Res. Vet. Sci.* 91: e48-e52.
23. Oyarzabal OA, Backert S, Nagaraj M, Miller RS, Hussain SK, Oyarzabal EA. (2007). Efficacy of supplemented buffered peptone water for the isolation of *Campylobacter jejuni* and *C. coli* from broiler retail products. *Microbiol. Meth.* 69(1): 129-136.
24. Pratt A, Korolik V. (2005). Tetracycline resistance of Australian *Campylobacter jejuni* and *Campylobacter coli* isolates. *Antimicrob. Chemother.* 55: 452-460
25. Pickett CL, Whitehouse CA. (1999). The cytolethal distending toxin family. *Trends Microbiol.* 7: 292-297.
26. Purdy D, Buswell CM, Hodgson AE. (2000). Characterisation of cytolethal distending toxin (CDT) mutants of *Campylobacter jejuni*. *Med. Microbiol.* 49: 473-479.
27. Rantsiou K, Lamberti C, Coccolin L. (2010). Survey of *Campylobacter jejuni* in retail chicken meat products by application of a quantitative PCR protocol. *Int. J. Food Microbiol.* 141, (31): S75-S79.
28. Saito S, Yatsuyanagi J, Harata S, Ito Y, Shinagawa K, Suzuki N, Amano K, Enomoto K. (2005). *Campylobacter jejuni* isolated from retail poultry meat, bovine faeces and bile, and human diarrheal samples in Japan: Comparison of serotypes and genotypes. *FEMS Immunol. Med. Microbiol.* 45(2): 311-319.
29. Sambrook J, Fritsch EF, Maniatis T. (1989). *Molecular Cloning: A Laboratory Manual*, vol. 1. 2<sup>nd</sup> ed. Cold Spring Harbor Laboratory Press
30. Shreeve JE, Toszeghy M, Pattiso M, Newell DG. (2000). Sequential spread of *Campylobacter* infection in a multipen broiler house. *Avian Dis.* 44: 983-988
31. Steinbruecker B, Ruberg F, Kist M. (2001). Bacterial genetic fingerprint: a reliable factor in the study of the epidemiology of human *Campylobacter enteritis*. *Clin. Microbiol.* 39: 4155-4159.
32. Whitehouse CA, Balbo PB, Pesci EC, Cottle DL, Mirabito PM, Pickett CL. (1998). *Campylobacter jejuni* cytolethal distending toxin causes a G<sub>2</sub>-phase cell cycle block *Infect. Immun.* 66: 1934-1940
33. Young KT, Davis LM, DiRita VJ. (2007). *Campylobacter jejuni*: molecular biology and pathogenesis. *Nat. Rev. Microbiol.* 5: 665-679.
34. Yu LSL, Uknalis J, Tu S. (2001). Immunomagnetic separation methods for the isolation of *Campylobacter jejuni* from ground poultry meats. *Immunol. Meth.* 256(1-2): 11-18.
35. Zorman T, Heyndrickx M, Uzunovic-Kamberovic S, Mozina SS. (2006). Genotyping of *Campylobacter coli* and *Campylobacter jejuni* from retail chicken meat and human with campylobacteriosis in Slovenia and Bosnia and Herzegovina. *Int. J. Food Microbiol.* 110: 24-33.

9/6/2012

## Detection of Avian Influenza (H5N1) In Some Fish and Shellfish from Different Aquatic Habitats across Some Egyptian Provinces

A.E. Eissa<sup>1</sup>, H .A. Hussein<sup>2</sup> and M.M. Zaki<sup>3</sup>

<sup>1</sup> Department of Fish Diseases and Management, Faculty of Veterinary Medicine, Cairo University, Giza 11221 Egypt.

<sup>2</sup> Department of Virology, Faculty of Veterinary Medicine, Cairo University, Giza 11221 Egypt.

<sup>3</sup> Department of Veterinary Hygiene and Management, Faculty of Veterinary Medicine, Cairo University, Giza 11221 Egypt.

[aeissa2005@gmail.com](mailto:aeissa2005@gmail.com)

**Abstract:** The global climatic changes impact on air, water and earth could extend scope of Avian Influenza (H5N1) virus to another broad sector of creatures including aquatic animals, especially those with direct relationship to aquatic birds. In the current study, Avian Influenza virus (H5N1) was detected in hemolymph of the Red Swamp crayfish (*Procambrus clarkii*) from three different provinces across the Nile Delta. Most of the positive cases were from the neighborhood of migratory bird natural stop stations. The virus was also detected in the Mediterranean Cone Shell (*Conus mediterraneus*) and the Pufferfish *Lagocephalus sceleratus* (Gmelin, 1789) during its course of invasion to the Mediterranean Sea. Two out of three poultry manure samples collected prior to earthen pond fertilization at three different localities were proved to be positive for the H5N1 virus. Tissue / mucous samples collected from earthen pond raised tilapias were negative for the virus. Catfish (*Clarias gariepinus*) has presented a striking model for aquatic species carrying the virus in their blood. The current results are suggestive for an important epidemiological role played by aquatic animals in spread of avian influenza (H5N1) virus across the Egyptian aquatic habitat.

[A.E. Eissa H .A. Hussein and M.M. Zaki. **Detection of Avian Influenza (H5N1) In Some Fish and Shellfish from Different Aquatic Habitats across Some Egyptian Provinces.** *Life Sci J* 2012;9(3):2702-2712] (ISSN:1097-8135). <http://www.lifesciencesite.com>. 394

**Key words:** Avian Influenza, H5N1, Crayfish, Nile tilapia, Catfish, Poultry manure

### 1. Introduction

The global surge of relatively large number of epidemics as well as pandemics has had deleterious impacts on world socioeconomics. During the past few decades, several epidemics have drastically influenced animals as well as human health. These conspicuous circumstances quicken the search for safe and secure alternatives to terrestrial animals and perhaps looking in the vast blue areas (water) covering more than 75 % of the globe. Aquaculture, the so called "Blue Revolution" was thought to be the ideal alternative to help get out of the dilemma. Unfortunately, due to interference of many environmental / biological factors that might possibly included global warming, aquaculture integration, maritime trade, globalization, overseas continental migratory bird' flyways; aquatic creatures became another vulnerable possible source for devastating pandemics.

Influenza viruses of avian origin have been implicated in outbreaks of influenza in marine mammals, such as harbor seals. Geraci *et al.*, 1982 have indicated that more than 400 harbor seals, most of them immature, died along the New England coast between December 1979 and October 1980 of an acute pneumonia associated with influenza virus

A/Seal/Mass/1/180 (H7N7). The isolated virus has avian characteristics, replicates principally in mammals, and causes mild respiratory disease in experimentally infected seals. In 1986, several influenza epidemics have erupted among the cetaceans 'populations at Atlantic and Pacific oceans (Hinshaw *et al.*, 1986). The nucleoprotein (NP) genes of influenza viruses were sequenced from a variety of virus isolates derived from marine mammals: whales from the Pacific / Atlantic oceans, seal and gull from the Western Atlantic, and a tern from the Caspian Sea (Mandler *et al.*, 1990). In comparison to published NP sequences, they found pairs of NPs derived from avian and marine mammal isolates to be closely related, e.g., the gull-whale and mallard-seal pairs from the Atlantic Coast of the USA and the tern-Pacific Ocean whale pair of the Eastern Hemisphere (Mandler *et al.*, 1990).

Known as integrated livestock-fish farming, the technique involves transferring the wastes from raising pigs, ducks or chickens directly to fish farms, with chicken or duck sheds sometimes located directly over the fish ponds themselves. At the correct amount, the nutrients in the manure give potential stimulus to the growth of plankton in the ponds, which are the predominant food for fish such as carp,

tilapia and mugil. Several authors have emphasized that integrated fish farming is now the main basis for aquaculture in China and many bordering countries (Little and Muir, 1987; Edwards *et al.*, 1988; Phong, 2010). Integrated farming with a fish species provides an efficient usage of on-farm resources, increased food and income opportunities, fewer economic risks through farm diversity, and especially effective disposal of crop residues and animal wastes by recycling these materials into high quality fish protein (Little and Muir, 1987; Edwards *et al.*, 1988; NACA, 1989). While the potential of integrated farming present a promising future for global economy, it should be noted that on-farm practice of integrated crop-livestock-fish farming represents less than one percent of farming populations in the tropical countries (Smith, 1988).

Scholtissek and Naylor (1988) were first to discuss the expected role of integrated fish farming systems in the spread of influenza pandemics. Further, Experimental studies suggest that there might be strong links between the resurgence of influenza A virus epidemics and the integration of aquaculture with duck and pig farming close to human dwellings. The transmission of genetic material from ducks to human influenza viruses seems to occur by reassortment in pigs (Kida *et al.*, 1994; Dong *et al.*, 2011). Pigs can become infected with and may transmit both human and avian influenza viruses not only to other pigs but also to the original avian host (Kida *et al.*, 1994; Furuse *et al.*, 2010). Thus, pigs are thought to be 'mixing vessels' where reassortment between avian and human influenza A viruses occurs, resulting in an antigenic shift that ends with the evolution of new human influenza strains with new surface antigens (Kida *et al.*, 1994; Itoa and Kawaoka, 2000; Furuse *et al.*, 2010). For this specific reason, Scholtissek and Naylor (1988) have recommended the development of integrated aquaculture systems in which pigs are reared in enclosed farms away from ducks.

Throughout the past few decades, poultry manure has been widely used as a major source of organic fertilizer to fish ponds in several nations along the Asian continent (Hu and Zhou, 1989; Subosa, 1992; Knud-Hansen *et al.*, 1993). The main reason for adding animal manures to fish ponds is to provide degradable organic matter, which is the most important component to promote the growth of bacteria (Schroeder, 1980; Hu and Zhou, 1989). During the decomposition of such bacteria, CO<sub>2</sub>, phosphorus, nitrogen are liberated to constitute essential constituents for phytoplankton's growth (Schroeder, 1980). Planktons represent the bottom of the food chain for fish. Partially, poultry manure can be directly utilized as a food for several cultured fish

species like tilapia, mullet and carp (Phong *et al.*, 2007).

Although the recycling of manure in integrated agriculture-aquaculture farming systems presents numerous benefits, the transmission / spread of diseases to human via aquatic organisms multiplying in excreta-laden water requires special attention. There is strong evidence that aquatic organisms may be more important vectors for human diseases than generally realized. However, conclusive epidemiological studies linking the use of excreta in aquaculture with human diseases are lacking (Naegel, 1990). Great portion of the huge increase in China's recent inland aquaculture production is attributed to organic fertilization, provided by the parallel spectacular growth of poultry and pig production. In the past few years, some global wildlife organizations such as Birdlife International has called for an investigation into the possibility that these thousands of manure-fed ponds across Asia may be the means by which the lethal strain of avian influenza, H5N1, is being spread. Birdlife has declared that outbreak of H5N1 occurred in 2004 / 2005 at diverse locations in China, Romania and Croatia where linked to the locations at which fish ponds are widely distributed (Feare, 2006).

Although the concentration of viruses and bacteria leaching from the manure into the aquaculture system is reduced drastically by dilution, filter feeders (e.g. mullet, shrimps, crayfish and snails) can concentrate these pathogens in its body fluids / surface. Despite the die-off pattern associated with this condition and high dilution in the water, they can propose a possible health hazard (Naegel, 1990). Author has also emphasized that convincing epidemiological studies still have to be done to link the risk of bacterial/viral infections to the consumption of aquatic organisms produced in manure-laden ponds. In recent studies, however, it has been proven that after exceeding a rather clearly defined threshold concentration of pathogens in the water, both viruses and bacteria are able to penetrate into the peritoneal fluid and even into the muscles of fish (Buras *et al.*, 1985; Buras *et al.*, 1987). This has an impact on the transmission of viruses and bacteria to persons who have direct contact with the intra-peritoneal fluid and blood of infected fish, like fish handlers and housewives when they are cutting, gutting and cleaning fish in preparation.

There has been overall agreement between the findings of various influenza surveillance studies in migratory birds in regard to the role played by birds in the emergence of pandemics in humans, lower animals, and domestic poultry (Halvorson *et al.*, 1983). The occurrences of outbreaks of highly pathogenic avian influenza H5N1 in Romania,

Turkey and Croatia in October 2005 have all been close to wetlands (Feare, 2006). This, together with their timing, has implicated the migration of migratory aquatic birds from southern Siberia in bringing the virus to Eastern Europe. In autumn 2004, stacks of poultry waste, including dead birds, were dumped next to fish farms at Varazdin, Northeast Croatia (Feare, 2006). The dead bird's stacks were left to seep into the ponds as fertilizer. In Serbia, manufactured poultry manure fertilizers are added to fish ponds; they are believed to be imported but their origin was not known. The association of some wild bird deaths with proximity to fish farms led to this search for information on fish farming practices that could be involved in avian influenza transmission (Feare, 2006). It is imperative to recognize that virus movement between wild birds and poultry is not a one-way street. For example, wild birds may become infected through feeding on infected poultry carcasses (Kwon *et al.*, 2005), and the practice of fertilizing fish ponds with poultry manure, which is widespread in Asia and Eastern Europe, proposes a route by which a wide range of aquatic birds might become infected (Melville and Shortridge, 2006; Bennum, 2006; Brown, 2006).

Molecular techniques such reverse transcriptase polymerase chain reaction (RT-PCR), multiplex transcriptase PCR and real time PCR are the most accurate / rapid tools for the detection of viral particles in clinical specimen as well as environmental samples (Saberfar *et al.*, 2007; Koehler *et al.*, 2008). RT-PCR can also be utilized as a rapid screening method for the simultaneous detection of type A influenza virus, H5 and H9 subtypes in clinical samples (Saberfar *et al.*, 2007; Ip *et al.*, 2008).

The main goal of the current study is to investigate the possible epidemiological role played by some fish /shellfish including native and invasive species in transmission and spread of the avian influenza (H5N1) virus across the Egyptian aquatic habitat.

## 2. Materials and Methods

### Sampling locations:

Sampling locations selection criteria was based upon previous Egyptian official reports on the detection of the Avian Influenza virus in poultry populations from several provinces scattered through the Nile delta. Thus, our sampling protocol was planned to cover vast areas of freshwater as well as marine aquatic habitats located at the basin and within the core of poultry farms neighborhood at these provinces (Plate 1). Definite sampling sites have included several earthen ponds at Sharkiya (Abassa and Eltel-Elkabeir), Manzala Lake basin at

both Dakhleya and Damietta, Port Said (Ashtoum Algami Natural Wilderness) and Alexandria (Abou-Qir Bay) (Plate 1).

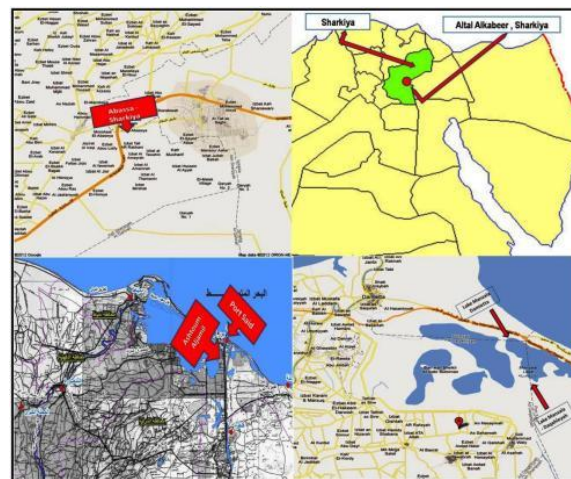


Plate (1). A map showing the geographical locations of fish / shellfish sampling sites.

### Sample collection:

Throughout the period from July 2010 till September 2011 a total of 160 live red swamp crayfish (*Procambrus clarkii*), 30 Mediterranean cone shell (*Conus mediterraneus*), 25 Pufferfish (*Lagocephalus sceleratus*), 30 sharp toothed catfish (*Clarias gariepinus*) and 400 live Nile tilapia (*Oreochromis niloticus*) fingerlings, were collected from number of earthen pond based fish farms located at the vicinity of the migration route of some transcontinental migratory aquatic birds crossing the mid-zone of the Egyptian Nile Delta at the above mentioned locations (Table 1). The endemic nature of avian influenza virus (H5N1) were the triggering factor behind selection of certain delta provinces as sites for wild aquatic bird / poultry manure sampling. Cloacal swabs from a total of 15 herrons (5 Abassa / Sharkiya, 5 Altal Alkabeer / Sharkiya and 5 Lake Manzalla / Damietta) were pooled into three samples, each representing a single geographical locality (Table 2). Further, a total of 10 colacal swabs (2 pools) were collected from wild ducks (5 Bahr Albaqar / Sharkiya and 5 Lake Manzalla / Damietta). A total of 15 poultry manure samples (3 pools of 100 gm each) were collected from some of recently fertilized earthen ponds within the vicinity of Sharkiya (Abassa), Dakhleya (Lake Manzalla), and Damietta (Shatta) (Table 2).

### Sample processing:

Nile tilapias and Red Swamp crayfish were transferred alive to the wet lab of the Fish Diseases and Management Laboratory (FDML) using well aerated insulated Styrofoam boxes. Pufferfish and

oysters were collected alive from Abou Qir Bay then transferred to the FDML using ice filled standard insulated ice boxes. Pooled samples from mouth parts, crusts and thoracic legs of adult Red swamp crayfish were finely homogenized using sterile homogenizer. Pooled sample of juvenile nymphal stages of crayfish were minced together using sterile pair of scissors then further homogenized. Homogenates were further diluted using Hanks balanced salt solution (HBSS: Sigma Chemical Co, St. Louis, MO, USA) (4 HBSS / 1 homogenate). Hemolymph samples from adult crayfish were collected using sterile syringes then aliquoted into 1 ml microfuge tubes. Diluted homogenates / hemolymph were stored at -80 °C freezer till processed.

All fish samples were washed up using 70 % ethanol before being dissected (Kidneys were retrieved from fish after opening under complete aseptic condition using three line incision). Mucous / fins mixture, gills and kidneys of Nile tilapia were finely homogenized using sterile homogenizer. Only blood samples were collected from the caudal vessels of sharp toothed catfish that were recently predated on dead bird carcasses as reported by the fish ponds owners (Plate 3-B). Blood samples were quickly aliquoted into 2 ml microfuge tubes and stored at 80 °C freezer till processed. Pufferfish kidney samples were transferred into sterile falcon tubes then further finely homogenized before being stored at -80 °C. Whole oysters were washed up using 70 % ethanol then flesh from each individual gastropod was dissected using sterile pair of scissors and forceps. Flesh tissues were transferred to 1 ml microfuge tube then finely homogenized using sterile homogenizer and stored at 80 °C freezer till processed.

Ducks and herons were trapped using duck traps and clap nets. Cloacal swabs were collected using cotton swabs and subsequently stored in transport media at -80°C. Transport media consisted of Hanks balanced salt solution supplemented with 10 % glycerol, 200 U/ml penicillin, 200 µg/ml streptomycin, 100 U/ml polymyxin B sulphate, 250 µg/ml gentamicin and 50 U/ml nystatin (All from, Sigma Chemical Co, St. Louis, MO, USA). In respect to poultry manure samples, random amounts (1gm from each pool) were stored in transport media at -80°C till processed.

#### **RNA isolation:**

RNA was extracted from the collected samples using Trizol<sup>®</sup> LS Reagent (Invitrogen, Carlsbad, CA) or the QIAamp<sup>®</sup> Viral RNA Mini Kit (Qiagen Inc., Valencia, CA) following manufacturers' instructions with minor modifications. A 0.2 ml sample was homogenized by vortexing and subsequently lysed

with 0.4 ml lysis/binding buffer. After binding to the column, DNase-I digestion and washing, the RNA was eluted in 50 µl nuclease-free double-distilled water. Initially, pools of 5 samples are tested (without significant loss of sensitivity).

#### **RT-PCR:**

Samples were amplified in a one-step RT-PCR in 25 µl final volume, containing 50 mM Tris. HCl pH 8.5, 50 mM NaCl, 7 mM MgCl<sub>2</sub>, 2 mM DTT, 1 mM each dNTP, 0.4 µM each oligonucleotide, 2.5 U recombinant RNasin, 10 U AMV reverse transcriptase, 2.5 U Ampli-Taq DNA polymerase (all enzymes from Invitrogen) and 5 µl RNA. Primers to detect any type A influenza viral genome located at M gene as well as the H5-specific primers were adopted from a previous protocol described by Saberfar *et al.* (2007). The sequences of the designed primers were MF: 5' CTT CTA ACC GAG GTC GAA ACG 3' and MR: 5' AGG GCA TTT TGG ACA AAG CGT CTA 3' for M gene amplification. The used H5-specific primers were H5F: 5' ACG TAT GAC TAT TCA CAA TAC TCA G 3' and H5R: 5' AGA CCA GCT ACC ATG ATT GC 3'. Thermo-cycling was performed in a thermal cycler (Bio-Rad, Hercules, CA) using the following cycling conditions: 30 minute at 42°C, 4 minutes at 95°C once; and 1 minute at 95°C, 1 minute at 45°C, 3 minutes at 72°C repeated 40 times.

### **3. Results**

#### **Freshwater fish and shellfish:**

RT-PCR results for the hemolymph samples of the freshwater crayfish (*Procambrus clarkii*) collected from Abassa / Sharkiya have revealed that 3 out of 4 pools were positive for H5N1 virus while all hemolymph samples of Altal –Elkabeer crayfish were positive (4 out of 4 pools). A total of 2 out of 3 whole minced freshwater crayfish juveniles collected from Abassa / Sharkiya were positive for the virus while all samples collected from Altal –Elkabeer were negative for the virus. It is worthy to mention that all crust-legs-mouth parts samples collected from both locations were negative (Plate 2 B) (Table 1).

As a positive remark for the endemic existence of the virus in crayfish, we have found that all hemolymph samples collected from Port Said and Damietta earthen ponds were positive for the virus. Controversially, all Nile tilapia's mucous; fins, gills and kidney samples collected from Abassa / Altal Elkabeer Sharkiya were negative for the H5N1 virus. RT-PCR test has confirmed that all blood samples collected from the bottom feeder sharp toothed catfish at Lake Manzala / Damietta were positive for the virus (Plate 2 A) (Table 1).



Table (1) Fish and shellfish sampling details and Avian Influenza virus detection results

Sampled Species	Province	Sampling location	Aquatic habitat	Sampled stage	Average Weight	Sampled tissue	Number samples	RT-PCR results	
								# +	# -
Freshwater Crayfish	Abassa	Earthen pond	Adult	50	Crust- legs - mouth parts	5 (1 pool)	0	1	
			Adult	50	Hemolymph	20 (4 pools)	3	1	
			Juvenile	20	Whole minced	15(3 pools)	2	1	
			Adult	70	Crust- legs - mouth parts	5 (1 pool)	0	1	
	Sharkiya	Earthen pond	Adult	70	Hemolymph	20 (4 pools)	4	0	
			Juvenile	30	Whole minced	15 (3pools)	0	3	
			Adult	45	Hemolymph	40 (4 pools)	4	0	
	Port Said	Ashtoum Algamil	Earthen Pond	Adult	40	Hemolymph	40 (4 pools)	4	0
Damietta	Lake Manzala	Earthen Pond	Adult	40	Hemolymph	40 (4 pools)	4	0	
Nile tilapia	Abassa	Earthen Pond	Fingerling	50	Mucous & fins	50 (5 pools)	0	5	
					Gills	50 (5 pools)	0	5	
					Kidney	100 (10 pools)	0	10	
	Sharkiya	Earthen Pond	Fingerling	50	Mucous & fins	50 (5 pools)	0	5	
					Gills	50 (5 pools)	0	5	
					Kidney	100 (10 pools)	0	10	
Sharp toothed Catfish	Damietta	Lake Manzala	Earthen Pond	Adult	600	Blood	30 (3 pools)	3	0
Rabbitfish	Alexandria	Abou Qir Bay	Mediterranean Sea coastal water	Adult	1000	Kidney	25 (5 pools)	4	1
Mediterranean Cone Shell			Mediterranean Sea coastal water	Adult	50	Whole flesh	30 (3 pools)	3	0

Table (2) Birds sampling and Avian Influenza virus detection results

Sampled Species	Province	Sampling location	Aquatic habitat	Average Weight / gm	Sampled tissue	Number samples	RT-PCR testing results	
							# +	# -
Herons	Abassa	Altal Alkabeer	Neighborhood of sampled Earthen ponds	1000	Cloacal swab	5 (1 pool)	1	0
				900	Cloacal swab	5 (1pool)	0	1
	Damietta	Lake Manzala	Neighborhood of sampled Earthen ponds	1050	Cloacal Swabs	5 (1pool)	0	1
Ducks	Sharkiya	Bahr Albaqar	Neighborhood of sampled Earthen ponds	1000	Cloacal swab	5 (1pool)	1	0
				1050	Cloacal Swabs	5 (1pool)	1	0
	Damietta	Lake Manzala	Neighborhood of sampled Earthen ponds	1050	Cloacal Swabs	5 (1pool)	1	0
Poultry	Dakhleya	Manzala	Earthen Ponds	100	Manure	5 (1pool)	1	0
	Damietta	Shatta	Earthen Ponds	100	Manure	5( 1pool)	1	0
	Sharkiya	Abassa	Earthen Ponds	100	Manure	5 (1pools)	1	0

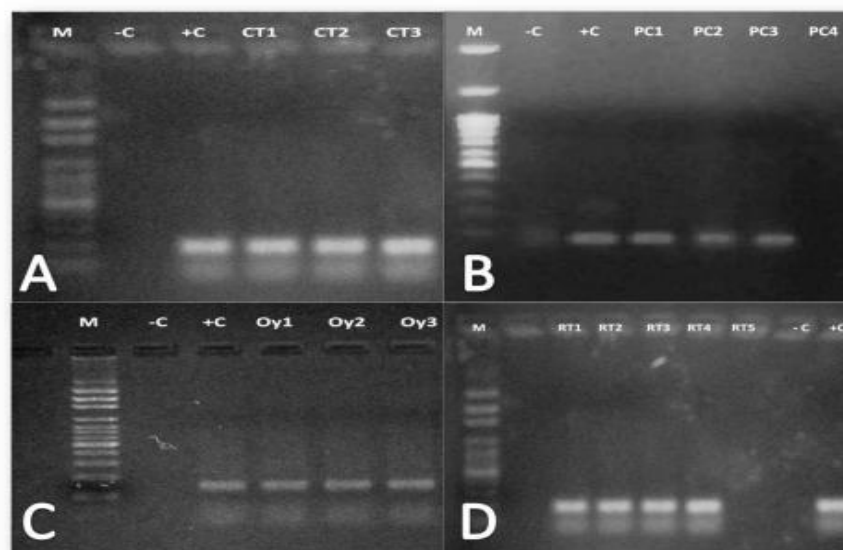


Plate (2) A. Agar gel electrophoresis showing specific bands for H5N1 positive catfish (CT) blood samples ; (2)B. Agar gel electrophoresis showing specific bands for H5N1 positive crayfish (PC) hemolymph samples; (2)C. Agar gel electrophoresis showing specific bands for H5N1 positive Mediterranean cone shell (OY) tissue samples; (2)D. Agar gel electrophoresis showing specific bands for H5N1 positive Pufferfish (RT) kidney samples.

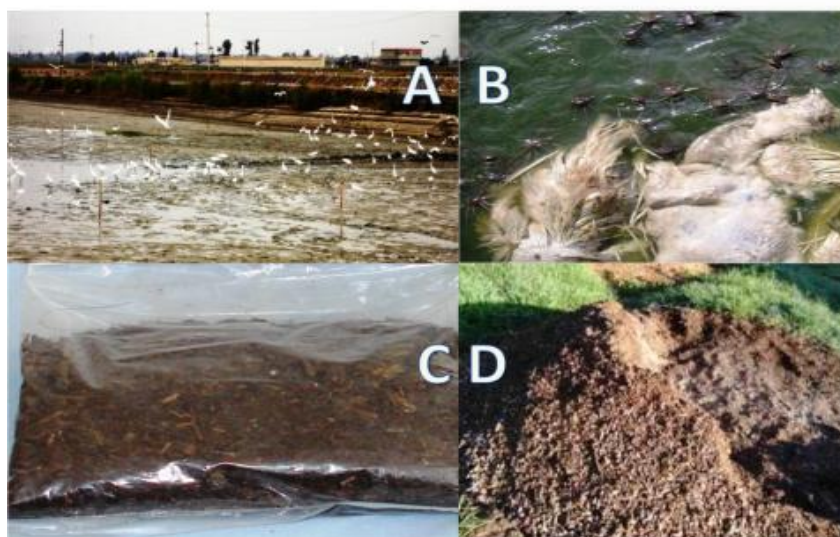


Plate (3)A. Herons dominating an aquaculture earthen pond; (3)B. Sharp toothed catfish preying on dead bird carcasses thrown at Manzala water body; (3)C. Poultry manure sample after collection ; (3) D. Poultry manure piles before earthen pond natural fertilization.

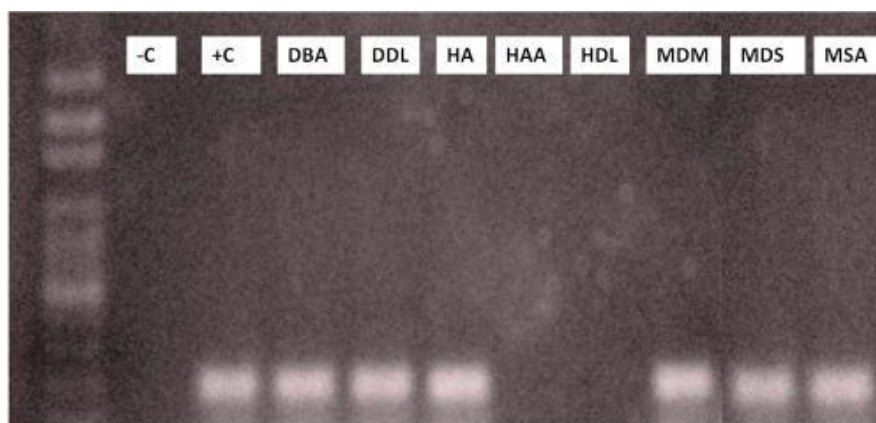


Plate (4) Agar gel electrophoresis showing the positive RT-PCR results of sampled aquatic birds: DBA: Ducks from Bahr Albaqar, Sharkiya; DDL: Ducks from Lake Manzala , Damietta ; HA : Herons from Abassa , Sharkiya; HAA: Herons from Altal Alkabeer, Sharkiya; HDL: Herons from Lake Manzala, Damietta ; MDM: Poultry manure from Manzala, Damietta; MDS: Poultry manure from Shatta, Damietta; MSA: Poultry manure from Abassa, Sharkiya

#### Marine fish and shellfish:

RT-PCR testing of the invasive Pufferfish (*Lagocephalus sceleratus*) collected from Abou Qir Bay , Alexandria has revealed that 4 out of 5 pools were positive for H5N1 virus (Plate 2 D) (Table 1) while whole flesh samples of the gastropod Mediterranean Cone Shell (*Conus mediterraneus*) were all positive (3 out of 3 pools) (Plate 2 C) (Table 1).

#### Poultry and manure samples:

RT-PCR tests indicated that cloacal swabs sampled from herons captured at Abassa / Sharkiya

were positive while that of Altal Alkabeer herons were negative for H5N1 virus. On the contrary, cloacal swabs from Damietta's herons were negative for the virus. Remarkably, Ducks' cloacal swabs from Bahr Albaqar / Sharkiya as well as Lake Manzala / Damietta were all positive for the virus. Ultimately, all poultry manure samples collected from recently fertilized earthen ponds at Manzala/ Dakhleya, Shatta/ Damietta and Abassa / Sharkiya were all positive for H5N1 virus (Plate 4, Table 2).

It should be noted that all tested samples were subject RT-PCR testing for type A influenza virus using M-gene primers then positive samples were

further subjected to RT-PCR testing for H5N1 virus using H5 gene primers.

#### 4. Discussion

During the past few years, Egypt has been stormed with numbers of influenza virus epidemics among human, poultry and swine populations. The peak of fatalities among human populations at different Egyptian provinces was mainly attributed to acute cases of swine flu (H1N1). On the other side, countable number of human mortalities scattered through vast geographical locations were mainly related to the vulnerable household rearing of different avian influenza (H5N1) possibly infected poultry populations (Aly *et al.*, 2008). However, the countable number of human cases was not reflecting the real crisis among the Egyptian poultry industry.

In 2006, the Egyptian government screening tools have discovered that a relatively large proportion of the poultry farms as well as backyard birds were positive for the virus (Aly *et al.*, 2008). This shocking news have triggered a very swift reaction from the veterinary authorities to stop the swift spread of the virus from state to another fearing the possible transmission to human populations Egypt's wide. By the end of 2006, millions of birds including farm, household and wild populations were subjected to total condemnation in a trial to eradicate the disease. Unfortunately, all control trials have faced absolute failure with an ultimate result that Office of International Epizootics (OIE) has listed Egypt among the avian influenza (H5N1) endemic states which became an existing fact till the moment (Aly *et al.*, 2008).

Throughout the past few years following the declaration of Egypt as an H5N1 endemic state, many researchers have been deeply investigating the real causes behind such national crisis. These investigations have involved numerous possible biological, environmental and administrative confounded artifacts that tragically ended with such national disaster. Researchers have followed several diversified assumptions which included but not limited to: application of faulty imported vaccine, un-tightened biosecurity procedures, improper eradication regimes, rearing of backyard poultry populations, wild bird migration flyways crossing north and south of Egypt, unhygienic disposal of dead birds' carcasses into the water bodies, habitual predation of carnivorous fishes on infected dead bird carcasses, predation of piscivorous birds on fish and shellfishes mechanically carrying the virus on/in their body surfaces/ tissues, and misuse of inefficiently treated poultry manure as aquaculture ponds fertilizers.

As an initial pilot study for our current 200 K Cairo university funded project titled "The roles played by shrimp, freshwater crayfish (*Procambrus clarkii*) and fish in the transmission and spread of Avian Influenza H5N1 at the Egyptian Territory "we have investigated the possible existence of the H5N1 influenza virus on/in surfaces, biological fluids and tissues of several fish and shell fish species from diverse geographical location scattered through Egyptian Nile delta. To be representative, we have collected samples from both open/closed aquatic habitats geographically located at the flyways of intercontinental bird migration as well as those neighboring poultry farms with previous history of endemic nature of H5N1 influenza virus.

Interestingly, all Nile tilapia (*O. niloticus*) mucus, fins, gills and kidney samples were free from the H5N1 viral particles which could attributed to the fact that cichlid family of fishes are surface feeders which means they selectively pick up their foods directly from the water surface. The earthen pond aquaculture facilities at Abassa / Altal Alkabeer, Sharkiya are open type facilities which utilize both artificial (floating or semi-floating pellets) and natural (surface water phytoplankton) foods which are the preferred type of food for Nile tilapias (Ita, 1980; World Bank, 1997; Popma and Masser, 1999). Thus, the sedimentation of H5N1 possibly infected piscivorous bird' droppings into the bottom of the aquaculture pond will deprive surface feeder fish like tilapia from apprehending such infected particulate matter. As a result of such gifted behavior, tilapias might not carry on the viral particles in / on their body tissues. Being omnivorous non predator fish (Ita, 1980; illay, 1990), tilapias are hypothetically unable to attack dead bird carcasses while floating in pond water surface, hence, their possibility of carrying viral particles are relatively nil. All above mentioned assumptions might explain how Nile tilapia samples from two diverse geographical locations are negative for the virus.

Red swamp crayfish (*Procambrus calrkii*) is a bottom filter feeding shellfish which sweeps the pond's bottom predated on several benthic organisms (Momot *et al.*, 1978; Scott and Thune, 1986; Darrigren, 2002). Thus, crayfish can engulf bottom settled benthic organism which could be parts of the settled down poultry droppings infected with H5N1 virus or any other pathogens. The well documented fact entailing the accidental presence of some pathogenic viruses (e.g. parvo virus) in the hemolymph of crayfish (Edgerton *et al.*, 1997) could explain how H5N1 influenza viral particles were detected in the hemolymph of the majority of Red swamp crayfish collected from the earthen ponds or even open water bodies at three different provinces

(Sharkiya, Damietta and Port Said). The presence of the three provinces at the scope of major migratory bird flyways, crowd of poultry farms as well as the faulty usage of poultry manure as fish pond fertilizers might explain the possible existence of H5N1 virus in both water and pond's bottom (Melville and Shortridge, 2006; Bennum, 2006; Brown *et al.*, 2007) for enough period that could approach several weeks (up to 190 days in wild viral strains) (Brown *et al.*, 2007) before being uptake by the filter feeder crayfish.

The erratic dumping of dead poultry carcasses into the water bodies is an environmental catastrophe that might represents a potential source for interspecies infectious diseases' transmission. Further, the predator feeding behavior of sharp toothed catfish could allow them to attack the dumped dead carcasses which were originally derived from an H5N1 infected neighboring poultry farm around Lake Manzala. After having such possibly infected meal, the virus could circulate in catfish blood for reasonable time till completely cleared. The bottom feeding behavior of catfish might add another predisposing factor for contracting H5N1 viruses from the precipitated poultry manure coming from either swimming migratory aquatic birds or poultry manure pond' fertilizers.

The biodiversity of the East Mediterranean has been considerably altered since the opening of the Suez Canal in 1869. The pufferfish, *Lagocephalus sceleratus* (Bilecenoglu *et al.*, 2006) is an alien fish species that has invaded the Mediterranean sea causing violent ecological alterations after escaping their native habitat (Indian Ocean) due to diverse ecological, food zone and climatic changes ( Halim and Rizkalla, 2011). Pufferfish are predominately feeding on dinoflagellates existing in the profound Mediterranean Sea 'depths (80 m), thus they are usual unintentional components of the fishing harvest by trawling machines at such areas of the Mediterranean (Golani and Levy, 2005; Aydin, 2011).

Interestingly, our RT-PCR screening assay has confirmed the presence of H5N1 viral particles in all examined kidney tissue samples of Pufferfish caught from Abou Qir Bay, Alexandria. The presence of H5N1 viral particles in kidney tissues could be derived from the feeding of pufferfish on possibly infected dinoflagellates followed by their digestion and sequential circulation in blood. Once viral particles got arrived to pufferfish blood, they could be lodged in their circulating phagocytes with an ultimate settling into the gut associated lymphoid tissues (GALT) and anterior kidney. This pathophysiological mechanism were imitated from similar viral infections belonging to the same influenza virus family (Orthomyxoviridae) infecting

fishes such as infectious salmon anemia (ISA) (Kibenge *et al.*, 2006). However, other non orthomyxoviridae viruses (infectious hematopoietic necrosis) were following the same sequential pathogenesis in different fish species (Kim *et al.*, 1999). Some viral species such as white spot syndrome virus (WSSV), Noda virus and other DNA viruses have been reported to infect dinoflagellates in marine environment (Nagasaki *et al.*, 2006; Tomaru *et al.*, 2009; Soumya *et al.*, 2012). Similarly, H5N1 virus could be incidentally slotted into dinoflagellates inhabiting the profound zones of Abou Qir Bay where they might be fed by the existing pufferfish allowing the viral particles to be settled in the fish's GALT and anterior kidney hematopoietic tissues .

Concurrently, the H5N1 viral particles were also detected in all soft tissues of the filter feeder cone shell (*Conus Mediterraneus*) collected from Abou Qir Bay, Alexandria. The H5N1 viral particles were possibly reached the soft tissues of the cone shell either by incidental lodging via filter feeding on the settled marine aquatic birds' droppings or by feeding on infected oligochaete worms. Our assumption was inferred from the fact that oligochaete worms were reported to be vulnerable source of transmission to many filter feeder shellfish specific viruses such as WSSV and Noda virus (Vijayan *et al.*, 2005; Katsanevakis *et al.*, 2008; Sudhakaran *et al.*, 2008; Jones, 2012).

Wild birds are considered to be the natural reservoirs of avian influenza virus (AIV) (Webster *et al.*, 1992) and the Anatidae (in particular ducks), many of which are long distance migrants, generally have a higher incidence of infection than other birds (Webster *et al.*, 1992). In early 2006, the expansion of H5N1 outbreak range has continued into more central parts of Europe and the Middle East, together with Africa and India (FAO, 2005). The proximity of these outbreaks to water bodies has led wild water birds to be blamed for virus introduction, e.g. the OIE report on the deaths of poultry (ducks and geese) in Kazakhstan stated that the birds had contracted the virus through contact with wildfowl on open reservoirs (FAO, 2005). Duck flocks are also frequently led to nearby ponds and lakes during the day, and taken back to the homestead at night where they mix with the remainder of the backyard poultry flock (FAO, 2005). There is thus a degree of association between avian influenza outbreaks and wetlands in many parts of south-east Asia and this has led to suspicions (in some circles claimed certainty) that wild water birds have been responsible for the spread of the virus.

Coinciding with the above reported data, all pooled Cloacal swabs collected from number of wild ducks caught at the nearby of fish ponds throughout

two different provinces (Sharkiya and Damietta) were positive for H5N1 virus. However, 50 % of Cloacal swabs collected from native wild herons caught at the nearby of fish ponds within two different sampling locations at Sharkiya province (Abassa and Altal Alkabeer) were positive for the virus. From different biological perspective, the predatory feeding behavior of migratory aquatic birds which naturally feed on aquatic invertebrates such as shrimps, crayfish and snails might set a reasonable hypothesis for their significant role in the epidemiological cycle of H5N1 virus in Egypt and worldwide.

The positive RT-PCR results of the poultry manure samples collected from earthen aquaculture ponds at three different Egyptian provinces (Sharkiya, Dakhleya and Damietta) prior to their usage as a pond fertilizer, is highly suggest for a very critical role in spread and transmission of H5N1 virus through integrated aquaculture systems adopted by many Egyptian aquaculture investors. These results coincided with many worldwide published reports confirming the possible role of poultry manure and integrated aquaculture in the spread and outbreaks of H5N1 virus (Bennum, 2006; Brown, 2006; Melville and Shortridge, 2006).

## 5. Conclusion

In conclusion, the majority of the retrieved data in our two years study has exposed the critical importance of many aquatic species in creating an intermediary link for transmission, processing and spread of influenza viruses to and from vulnerable aquatic and poultry populations (Kwon *et al.*, 2005). Further, it is very imperative to conclude that erratic dumping of dead bird carcasses into water bodies as well as faulty usage of inefficiently treated poultry manure in organic fertilization of fish ponds would result in catastrophic eruption and evolution of new influenza viral hybrids with an ultimate disaster of state wide pandemic. Ultimately, extensive pathogenicity studies are essential to investigate the assumed probability of the H5N1 virus to adapt and replicate in aquatic animal modules.

## Acknowledgments

We are very proud that the current research article is an end product to a current research project that is officially funded by Cairo University. We greatly appreciate the assistance of our colleagues Prof. Mohamed Moustafa and Prof. Mohamed Abdel Aziz from the Department of Fish Diseases and Management (FDM) for their valuable support during all research project phases. Also, we would like to thank Dr. Osama Saleh from the Central Laboratory for Aquaculture Research, Abassa, Sharkiya for his endless support during crayfish and Nile tilapia

collection. Ultimate thanks will be to Dr. Amany Elsameen, from the National Authority for Fish Wealth Development for her generous supply of fish, crayfish and water samples.

## Corresponding author

**Dr. Alaa Eldin Eissa**

Department of Fish Diseases and Management,  
Faculty of Veterinary Medicine, Cairo University,  
Giza

[aeissa2005@gmail.com](mailto:aeissa2005@gmail.com)

## References

1. Aly, M.M., Arafa, A., Hassan, M.K., 2008 . Epidemiological findings of outbreaks of disease caused by highly pathogenic H5N1 avian influenza virus in poultry in Egypt during 2006. *Avian Dis.* 52: 269–277.
2. Aydın, M., 2011. Growth, Reproduction and Diet of Pufferfish (*Lagocephalus sceleratus* Gmelin, 1789) from Turkey's Mediterranean Sea Coast. *Turk. J. Fish. Aquat. Sci.* 11, 569-576.
3. Bennum, L., 2006. Reality takes wing over bird flu. *BBC news.* <http://news.bbc.co.uk/1/hi/sci/tech/4721598.stm> (Accessed 22 February 2006).
4. Bilecenoglu, M., Kaya, M., Akalin, S., 2006. Range expansion of silverstripe blaasop, *agocephalus sceleratus* (Gmelin, 1789), to the northern Aegean Sea. *Aquat. Invas.* 1, 289-291.
5. Brown, D., 2006. Poultry, not wild birds, most often carries deadly avian flu to Africa. *Washington Post* 16 February 2006. <http://www.washingtonpost.com/wp-dyn/content/article/2006/02/15/AR2006021502324.html> (Accessed 22 February 2006).
6. Buras, N., Duek, L., Niv, S., 1985. Reactions of fish to microorganisms in wastewater. *Appl. Environ. Microbiol.* 50, 989-995.
7. Buras, N., Duek, L., Niv, S., Hopher, B., Sandbank, E., 1987. Microbiological aspects of fish grown in treated wastewater. *Water Res.*, 21, 1-10.
8. Darrigren, G., 2002. Potential impact of filter-feeding invaders on temperate inland freshwater environments. *Biol. Invas.* 4, 145–156.
9. Dong, G., Luo, J., Zhang, H., Wang, C., Duan, M., Deliberto, T.J., Nolte, D.L., Ji, G., He, H., 2011. Phylogenetic diversity and genotypical complexity of H9N2 influenza A viruses revealed by genomic sequence analysis. *PLoS One* 6(2), e17212.
10. Edgerton, B., Webb, R., Wingfield, M., 1997. A systemic parvo- like virus in the freshwater

- crayfish *Cherax destructor*. Dis. Aquat. Org. 29: 73-78.
11. Edwards, T. C., Collopy, M. W., Steenhof, K., Kochert, M. N., 1988. Sex ratios of fledgling Golden Eagles. Auk 105,793-796.
  12. FAO , 2005. Wild birds and avian influenza. [http://www.fao.org/ag/againfo/subjects/en/health/diseases/cards/avian\\_HPAI\\_risk.html](http://www.fao.org/ag/againfo/subjects/en/health/diseases/cards/avian_HPAI_risk.html).
  13. Feare, C. J. 2006 . Fish Farming and the Risk of Spread of Avian Influenza. Cambridge (United Kingdom) Bird Life International 1-9.
  14. Furuse, Y., Shimabukuro, K., Odagiri, T., Sawayama, R., Okada, T., Khandaker, I., Suzuki, A., Oshitani, H., 2010. Comparison of selection pressures on the HA gene of pandemic (2010) and seasonal human and swine influenza A H1 subtype viruses. Virology, 405: 314-321.
  15. Geraci, J.R., Aubin, S.t., Barker, D.J., Webster, I.K., Hinshaw, R.G., Bean, V.S. , Ruhnke, W.J., Prescott, H.L., Early, J.H., Baker, G., Madoff A.S. , Schooley, R.T. (1982). Mass mortality of Harbour Seals: pneumonia associated with influenza A virus. Science 215: 1129-1131.
  16. Golani, D., and Levy, Y., 2005. New records and rare occurrences of fish species from the Mediterranean coast of Israel. Zool Middle East 36, 27–32.
  17. Halim, Y., Rizkalla, S., 2011. Aliens in Egyptian Mediterranean waters. A check-list of Erythrean fish with new records. Medit. Mar. Sci. 12, 479-490.
  18. Halvorson, D., Karunakaran, D., Senne, D., Kelleher, C., Bailey, C., Abraham, A., Hinshaw, V. S., J. Newman, 1983. Epizootiology of avian influenza-simultaneous monitoring of sentinel ducks and turkeys in Minnesota. Avian Dis. 27: 77-85.
  19. Hinshaw, V.S., Bean, W.J., Geraci, J., Fiorelli, P., Early, G., Webster R.G., 1986. Characterization of two influenza A viruses from a pilot whale. J. Virol. 58, 655-656.
  20. Hu, B., Zhou, E., 1989. Review on development of integrated fish farming in China. Selected papers of freshwater fisheries research, Asian-Pacific Regional Research and Training Centre for integrated fish farming, p.89-110.
  21. Ip, H. S., Flint, P. L., Franson, J. C. , Dusek, R. J., Derksen, D. V. , Gill, R. E., Ely, C. R., (2008). Prevalence of influenza A viruses in wild migratory birds in Alaska: patterns of variation in detection at a crossroads of intercontinental flyways. J. Virol. 5, 71.
  22. Ita, E.O., 1980. Principles and practices of integrated commercial fish farming in Nigeria. Technical report series No. 19, National Institute for Freshwater Fisheries Research, New Bussa.
  23. Itoa, T., Kawaoka, Y., 2000. Host-range barrier of influenza A viruses. Vet. Microbiol. 74, 71-75.
  24. Jones, B., 2012. Transboundary movement of shrimp viruses in crustaceans and their products: A special risk? J Invertebr. Pathol. 110, 196-200.
  25. Katsanevakis, S., Lefkaditou, E., Galinou-Mitsoudi, S., Koutsoubas D., Zenetos, A. 2008. Molluscan species of minor commercial interest in Hellenic Seas: Distribution, exploitation and conservation status. Medit. Mar. Sci. 9(1), 77-118.
  26. Kibenge, F.S., Kibenge, M.J., Groman, D., McGeachy, S., 2006. *In vivo* correlates of infectious salmon anemia virus pathogenesis in fish. J. General Virol. 87, 2645-2652.
  27. Kida, H., Ito, T., Yasuda, J., Shimizu, Y., Itakura, C., Shortridge, K. F., Kawaoka, Y., Webster, R. G. , 1994. Potential for transmission of avian influenza viruses to pigs. J. General Virol. 75, 2183-2188.
  28. Kim, C. H., Dummer, D. M., Chiou, P. P., Leong, J. A., 1999. Truncated particles produced in fish surviving infectious hematopoietic necrosis virus infection: mediators of persistence? J Virol. 73, 843-849.
  29. Knud-Hansen, C.F., McNabb, C.D., Batterson, T.R., 1993. The role of chicken manure in the production of Nile tilapia (*Oreochromis niloticus*). Aquacult. Fish. Manage. 24, 483-493.
  30. Koehler, A. V., Pearce, J. M., Flint, P. L., Franson, J. C. , Ip, H., 2008. Genetic evidence of intercontinental movement of avian influenza in a migratory bird: the northern pintail (*Anas acuta*). Mol. Ecol. 17, 4754-4762.
  31. Kwon, Y.K., Joh, S.J., Kim, M.C., Lee, Y.J., Choi, J.G., Lee, E.K., Wee, S.H., Sung, H.W., 2005. Highly pathogenic avian influenza in Magpies (*Pica picasericca*) in South Korea. J Wildlife Dis. 41, 618–623.
  32. Little, D., Muir, J., 1987. A Guide to Integrated Warm Water Aquaculture. Institute of Aquaculture, University of Stirling, Stirling, Scotland, 238 pp.
  33. Mandler, J., Gorman, O.T., Ludwig, S., Schroeder, E., Fitch, W.M., Webster, R.G., Scholtissek, C., 1990. Derivation of the nucleoproteins (NP) of influenza A viruses isolated from marine mammals. Virology 176(1), 255-61.
  34. Melville, D.S., Shortridge, K., 2006. Spread of H5N1 avian influenza virus: an ecological conundrum. Lett. Appl. Microbiol. 42, 435–437.

35. Momot, W.T., Gowing, H., Jones, P. D., 1978. The dynamics of crayfish and their role in ecosystems. *Am. Midl. Nat.* 99, 10-35.
36. NACA, 1989. Integrated Fish Farming in China, A World Food Day Publication of the Network of Aquaculture Centres in Asia and the Pacific, Bangkok, Thailand. 278pp.
37. Naegel, L.C.A., 1990. A review of the public health problems associated with the integration of animal husbandry and aquaculture, with emphasis on Southeast Asia. *Biol. Wastes* 31, 69-83.
38. Nagasaki, K., Tomaru, Y., Shirai, Y., Takao, Y., Mizumoto, H., 2006. Dinoflagellate-infecting viruses. *J. Mar. Biol. Assoc.* 86, 469-74.
39. Phong, L.T., H.M.J. van Udo, M.E.F. Mensvoort, R.H. Bosma, L.Q. Tri, D.K. Nhan , A.J. van der Zijpp, 2007. Integrated agriculture-aquaculture systems in the Mekong Delta, Vietnam: an analysis of recent trends. *Asian J. Agric. Dev.* 4, 51-66.
40. Phong, L.T., 2010. Dynamics of sustainability in Integrated AgricultureAquaculture systems in the Mekong Delta. Ph.D. thesis. Wageningen Institute of Animal Sciences, Wageningen University, Wageningen, the Netherlands.
41. Pillay, T.V.R., 1990. *Aquaculture: Principles and Practices*. Fishing News Books, London, 575 pp.
42. Popma, T., Masser, M. 1999. *Tilapia Life History and Biology*. SRAC Publication No. 283
43. Saberfar, E., Forghani-fard, M., Mosavi, M., 2007. Multiplex RT-PCR Assay for Typing and Subtyping of Influenza A (H5 and H9) Virus in Iran. *Iran. Biomed. J.* 11 (2), 69-74.
44. Scholtissek, C., Naylor, E., 1988. Fish farming and influenza pandemics. *Nature*, 331, 215.
45. Schroeder, G.L., 1980. Fish farming in manure loaded ponds, p 73-86. In ICLARM- SEARCA Conference of Agriculture, Aquaculture and Farming System, Manila, Philippines.
46. Scott, J.B., Thune, R.L., 1986. Bacterial flora of hemolymph from Red Swamp Crawfish, *Procambarus clarkii* (Girard), from commercial ponds. *Aquaculture* 58, 161-165.
47. Smith, I., 1988. "Preface." In Peter Edwards, Roger S.V. Pullin, and James Gartner eds., *Research and Education for the Development of Integrated Crop-Livestock-Fish Farming Systems in the Tropics*. ICLARM Studies and Reviews 16. Manila: International Center for Living Aquatic Resources Management.
48. Soumya, J., Sekhar, K.S., Niharika, M., Mohanapria, K., 2012. Marine toxicity and its implication on human health. *Intern. Res. J. Pharm. online* 3(3), 39 - 42.
49. Subosa, P., 1992. Chicken manure, rice hulls, and sugar-mill wastes as potential organic fertilizers in shrimp (*Penaeus monodon* Fabricius) ponds. *Aquaculture* 102, 95-103.
50. Sudhakaran, R., Haribabu, P., Kumar, S.R., Sarathi, M., Ahmed, V.P.I. and Babu, V.S., 2008. Natural aquatic insect carriers of *Macrobrachium rosenbergii* nodavirus (MrNV) and extra small virus (XSV), *Dis. Aquat. Org.* 79, 141-145.
51. Tomaru, Y., Mizumoto, H. and Nagasaki, K., (2009). Virus resistance in the toxic bloom-forming dinoflagellate *Heterocapsa circularisquama* to single-stranded RNA virus infection. *Environ. Microbiol.* 11, 2915-2923.
52. Vijayan, K.K., Stalin Raj, V., Balasubramanian, C.P., Alavandi, S.V., Thillai Sekhar, V., Santiago, T.C., 2005. Polychaete worms as a vector for white spot syndrome virus (WSSV). *Dis. Aquat. Org.* 63, 107-111.
53. Webster, R.G., Bean, W.J., Gorman, O.T., Chambers, T.M., Kawaoka, Y., 1992. Evolution and ecology of influenza A viruses. *Microbiol. Rev.* 56, 152-179.
54. World Bank, 1997. Mexico Aquaculture Development Project. Report 16476-ME. Washington, DC.

9/2/2012

## Studies on Detoxification of Aflatoxins Contaminated Rabbits' Rations Treated with Clay and Ammonia

Helal S.H. Abu-EL-Zahab<sup>1,2</sup> Ahmed Abdel Aziz Baiomy<sup>1,2</sup> and Dalia Yossri Saad<sup>1,2</sup>

<sup>1</sup>Medical Biotechnology Department, Faculty of Applied Medical Sciences, Taif University, KSA

<sup>2</sup>Zoology Department, Faculty of Science, Cairo University, Egypt

[Aabdelaziz.baiomy@gmail.com](mailto:Aabdelaziz.baiomy@gmail.com)

**Abstract:** The aim of the present study is to investigate the effect of ammonia and clay on detoxification of aflatoxins contaminated Rabbits' rations. Four rations (control, aflatoxin contaminated ration, contaminated ration treated with ammonia (1%) and contaminated ration treated with clay (2%)) fed to 40 New Zealand male rabbits (10 animals each). The average daily weight gain of rabbits fed contaminated ration was reduced, whereas rabbits fed ration in addition to clay or ammonia showed weight gain. The increase in relative weight of the studied rabbit's organs (liver and kidneys) was reported in this study. However, the improvement in relative weight of internal organs of rabbits fed aflatoxin contaminated ration treated with clay, could be due to the protection effect of bentonite against aflatoxin and the alkaline effect of ammonia treatment on depressing the growing of fungi which reflect on less production of aflatoxin. Histopathological changes in liver of rabbits fed aflatoxin contaminated ration treated with clay at 45 and 90 days period and kidneys at 45 days period showed mild to moderate in severity. While the kidneys at 90 days period showed normal histological structure. Histopathological changes which occurred in liver and kidneys at 45 and 90 days period of rabbits fed contaminated ration treated with ammonia are considered mild changes and reversible. So, ammoniation or clay addition proved to be recommended as a cheapest way to inhibit the fungus growth and can detoxify its effect in rabbits feeds.

[Helal S.H. Abu-EL-Zahab Ahmed Abdel Aziz and Dalia Yossri. **Studies on Detoxification of Aflatoxins Contaminated Rabbits' Rations Treated with Clay and Ammonia.** *Life Sci J* 2012;9(3):2713-2721] (ISSN:1097-8135). <http://www.lifesciencesite.com>. 395

**Keywords:** Aflatoxins; Rabbits' rations; Ammonia; Clay; Liver; Kidney; Histopathology

### 1 Introduction

Aflatoxins refer to a group of extremely poisonous mycotoxins produced by two common fungi *Aspergillus flavus* and *Aspergillus parasiticus*. Mycotoxins are chemical compounds produced by fungi while growing on organic substances such as corn and peanuts (Wood, 1989). When animals or humans consume these compounds, they may produce severe undesirable health effects. Aflatoxins affect animal performance via reducing feed intake and growth and can cause serious economic problems for animal production industry (Brekke *et al.*, 1977; Rodgers *et al.*, 2002; Pfohl-Leszkowicz *et al.*, 2007; Asi *et al.*, 2012 and Somorin *et al.*, 2012). Aflatoxins are of great concern as carcinogenic, mutagenic and immunosuppressive substances (Eaton and Gallagher, 1994 and Theumer *et al.*, 2003). Signs of acute aflatoxicosis are seen as severe liver and kidney damage, hemorrhage, suppression of immune system and death (Moorthy *et al.*, 1985; Huff *et al.*, 1986 and Pier, 1992). Aflatoxin is toxic to embryonic human liver in tissue culture (Zuckerman *et al.*, 1967). Indeed rat fibroblasts in tissue culture are so sensitive to aflatoxin was able to develop a useful bioassay method on this basis (Daniel, 1965). In chronic aflatoxicosis, most of the effects are still referable to hepatic injury, but on a milder scale, reduction of feed intake and growth rate of young

animals and reduction of reproductive performance of adult animals (Diekman and Green, 1992; Lindemann *et al.*, 1993; Schell *et al.*, 1993 and Nowar *et al.*, 2000). The rabbit appears to be even more sensitive to the acute effects of aflatoxin than mammalian species (Abdelhamid *et al.*, 1985). In addition aflatoxin binds with DNA and RNA and prevents the protein synthesis in the body (Pier, 1992). There are different means for aflatoxin inactivation, physical and chemical methods (János *et al.*, 1995). Removing aflatoxins from contaminated foods and feedstuffs remaining a major problem and there is a great demand for effective decontamination technology (Janos *et al.*, 2010). Ammoniation of any infected materials with fungi and used in animal feed can come over the problem of aflatoxins produced by such fungi (Norred, 1990; Fayed, 1999 and Mahendra *et al.*, 2012). Clays are generally inert and non toxic to animals (Oliver, 1997) and have a capacity to bind aflatoxin (Phillips *et al.*, 1990 and Mahendra *et al.*, 2012). The dietary addition of zeolites (Kececi *et al.*, 1998; Bailey, 2006 and Dixon, 2008), bentonite (Oguz, 1997 and Magnoli *et al.*, 2008) and Egyptian tafla (Nowar and Abd EL-Mageed, 1996) have been used for reduction of aflatoxins toxicity *in vivo*.

### 2. Materials and Methods

#### Animals:

Forty growing New Zealand white male rabbits



aged one month and half were divided into four groups. All groups were equal in number (10 rabbits each). All rabbits were approximately similar in their initial body weight at the beginning of the experiment. They were fed the experimental rations to meet nutrient requirements of rabbits during the growing period according to Nutrient Research Council (NRC, 1977).

#### The experimental groups:

Group 1 (G1): Aflatoxin free ration (Control group). Group 2 (G2): Aflatoxin contaminated ration. Group 3 (G3): Aflatoxin contaminated ration treated with 2% clay (Nowar *et al.*, 2001). Group 4 (G4): Aflatoxin ammoniated ration, treated with anhydrous ammonia at 1% concentration (Sundstol *et al.*, 1978). For each dietary treatment three rabbits were randomly chosen at the middle and the end of the experimental period, all rabbits were fasted before slaughtering. The slaughter test was performed at 45 and 90 days of the experimental period. The three rations group was compared to a control ration free from aflatoxin contamination.

#### Microorganism:

*Aspergillus flavus*, NRRL 2999 (Chohal and D. Howks Worth laboratory U.S.A.). Aflatoxin was produced according to the method by Shotwell *et al.* (1966) and Sharon *et al.* (1973).

#### Average of live body weight (LBW):

Live body weight of rabbits was recorded individually at beginning and at weekly intervals to the nearest gram until the end of the experimental period. Weighing was done in early morning before receiving feed or water.

#### Average of live body weight gain (BWG):

The BWG was calculated at the end of the experimental period, by subtracting the LBW from the weight at the end of the experiment, then divided by the experimental period.

#### Histopathological examination:

Samples for histopathological examination were taken from liver and kidney at 45 and 90 days period. Liver and Kidney were fixed in 10% neutral buffer formalin solution then washed in tap water and dehydrated by different grades of alcohol and cleared by xylene then embedded in paraffin. The paraffin embedding blocks were cut at 4-5 $\mu$ m thick. The sections were routinely stained with haematoxylin and eosin (Bancroft and Cook, 1994).

#### Statistical analysis:

All statistical analysis were done according to SAS (1998).

### 3. Results

#### Growth performance:

Data in tables (1, 2 and 3) presented the growth performance of rabbits fed the experimental rations. Average daily gain of rabbits fed

contaminated ration (G2) was reduced by about 56.1% when compared with the control group (G1) after 45 days. While the reduction was 64.3% at 45-90 days period, whereas the overall period (90 days) was 64.2%. Rabbits fed ration in addition to clay (G2) gained 29.8% more than the control after 45 days; 2.4% at 45-90 days and 15.3% after 90 days. Rabbits in group G4 showed a percentage of 17.9 more gain after 45 days and 8.2% at the overall period (0-90 days) compared to the control (G1), while it had less gain reached 1.1% at 45-90 days period than G1.

**Table 1:** Animal growth performance for rabbits fed the experimental rations for 45 days (Mean  $\pm$  SE). a,b,c and d: Means in the same row with different

Items	G1	G2	G3	G4
IBW (g)	939.80 $\pm$ 3.13	940.6 3 $\pm$ 6.17	940.00 $\pm$ 2.14	940.63 $\pm$ 3.11
FBW (g)	1860.8 5 <sup>c</sup> $\pm$ 12.40	1345.00 <sup>c</sup> $\pm$ 11.11 <sup>d</sup>	2135.63 <sup>a</sup> $\pm$ 23.10	2026.25 <sup>a</sup> $\pm$ 18.19
Daily gain (g)	21.93 <sup>b</sup> $\pm$ 1.22	9.63 <sup>c</sup> $\pm$ 0.16	28.47 <sup>a</sup> $\pm$ 2.14	25.85 <sup>a</sup> $\pm$ 3.13
% difference from G1	-	-56.1	+29.8	+17.9

superscripts are significantly different (P<0.05).

**Table 2:** Animal growth performance for rabbits fed the experimental rations from 45 to 90 days (Mean  $\pm$  SE).

Items	G1	G2	G3	G4
IBW (g)	1851.82 <sup>c</sup> $\pm$ 24.16 <sup>d</sup>	1267.78 <sup>e</sup> $\pm$ 37.14	2180.83 <sup>a</sup> $\pm$ 20.11	2063.85 <sup>b</sup> $\pm$ 19.18
FBW (g)	3330.85 <sup>c</sup> $\pm$ 44.15	1796.25 <sup>e</sup> $\pm$ 48.17	3695.20 <sup>a</sup> $\pm$ 41.14	3527.46 <sup>b</sup> $\pm$ 39.15
Daily gain (g)	35.22 <sup>a</sup> $\pm$ 1.20	12.58 <sup>c</sup> $\pm$ 2.15	36.06 <sup>a</sup> $\pm$ 0.85	34.85 <sup>a</sup> $\pm$ 0.91
% difference from G1	-	-64.3	+2.4	-1.1

a,b,c,d and e: Means in the same row with different superscripts are significantly different (P<0.05).

**Table 3:** Animal growth performance for rabbits fed the experimental rations from 0 to 90 days (Mean  $\pm$  SE).

Items	G1	G2	G3	G4
IBW (g)	939.80 $\pm 2.14$	940.63 $\pm 2.34$	940.00 $\pm 1.95$	940.63 $\pm 3.02$
FBW (g)	3330.85 $\pm 6.15$	1796.25 $\pm 11.11$	3695.20 $\pm 9.17$	3527.46 $\pm 13.20$
Daily gain (g)	28.46 <sup>b</sup> $\pm 0.16$	10.19 <sup>c</sup> $\pm 1.13$	32.80 <sup>a</sup> $\pm 2.21$	30.80 <sup>ab</sup> $\pm 1.90$
% difference from G1	-	-64.20	+15.30	+8.20

a,b,c,d and e: Means in the same row with different superscripts are significantly different ( $P < 0.05$ ).

#### Relative organs weight to live body weight of rabbits:

Relative organs weight to live body weight of rabbits fed the experimental rations are presented in table (4) after 45 days and table (5) after 90 days. Rabbits fed aflatoxin contaminated ration (G2) showed heavier ( $P < 0.05$ ) relative weight of liver (3.70%), kidneys (0.92%) after 45 days and (3.52 and 1.08) for both liver and kidney respectively after 90 days than those fed aflatoxin free ration (G1). Other groups of rabbits had no significant relative weight of liver and kidneys to live body weight after both 45 and 90 days periods.

**Table 4:** The effect of the experimental rations on relative organs weight (Liver and kidney) to live body weight of rabbits after 45 days of the experiment (Mean  $\pm$  SE).

Items	G1	G2	G3	G4
Live body weight (g) "Pre slaughter"	1900.00 <sup>b</sup> $\pm 4.87$	1436.67 <sup>c</sup> $\pm 7.72$	1933.33 <sup>a</sup> $\pm 8.89$	1863.33 <sup>c</sup> $\pm 11.20$
Liver weight (g)	49.00 <sup>b</sup> $\pm 1.11$	53.13 <sup>a</sup> $\pm 2.02$	51.67 <sup>ab</sup> $\pm 2.12$	49.33 <sup>b</sup> $\pm 1.00$
Relative liver weight (%)	2.58 <sup>b</sup> $\pm 0.61$	3.70 <sup>a</sup> $\pm 0.06$	2.67 <sup>b</sup> $\pm 0.72$	2.65 <sup>b</sup> $\pm 0.12$
Kidneys weight (g)	14.33 <sup>a</sup> $\pm 0.01$	13.31 <sup>a</sup> $\pm 0.55$	14.77 <sup>a</sup> $\pm 0.11$	14.07 <sup>a</sup> $\pm 0.21$
Relative kidneys weight (%)	0.75 <sup>b</sup> $\pm 0.49$	0.92 <sup>a</sup> $\pm 0.04$	0.77 <sup>b</sup> $\pm 0.91$	0.75 <sup>b</sup> $\pm 0.84$

a,b,c,d and e: Means in the same row with different superscripts are significantly different ( $P < 0.05$ ).

#### Histopathological lesions:

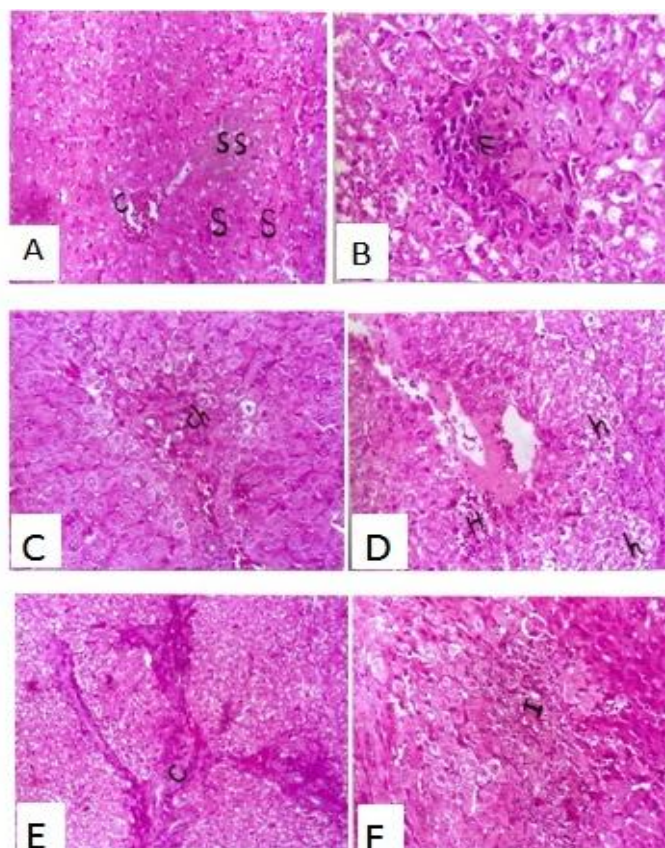
No histopathological lesions were detected in liver and kidneys of rabbits fed the normal ration (control group) from beginning up to the end of the experimental period.

**Table 5:** The effect of the experimental rations on relative organs weight (Liver and kidney) to live body weight of rabbits after 90 days of the experiment (Mean  $\pm$  SE).

Items	G1	G2	G3	G4
Live body weight (g) "Pre slaughter"	3063.67 <sub>bc</sub> $\pm 66.14$	1913.33 <sub>d</sub> $\pm 38.42$	3478.34 <sub>a</sub> $\pm 21.41$	3165.67 <sub>b</sub> $\pm 48.24$
Liver weight (g)	74.58 <sup>a</sup> $\pm 6.33$	67.31 <sup>c</sup> $\pm 5.35$	85.09 <sup>a</sup> $\pm 2.37$	75.81 $\pm 1.07$ <sup>b</sup>
Relative liver weight (%)	2.43 $\pm 0.22$ <sup>c</sup>	3.52 $\pm 0.10$ <sup>a</sup>	2.45 $\pm 0.15$ <sup>c</sup>	2.39 <sup>c</sup> $\pm 0.10$
Kidneys weight (g)	22.55 <sup>bc</sup> $\pm 0.11$	20.70 <sup>c</sup> $\pm 3.14$	26.03 <sup>a</sup> $\pm 0.81$	23.83 <sup>ab</sup> $\pm 2.12$
Relative kidneys weight (%)	0.74 <sup>b</sup> $\pm 0.33$	1.08 <sup>a</sup> $\pm 0.13$	0.75 <sup>b</sup> $\pm 0.03$	0.76 <sup>b</sup> $\pm 0.11$

a,b,c,d and e: Means in the same row with different superscripts are significantly different ( $P < 0.05$ ).

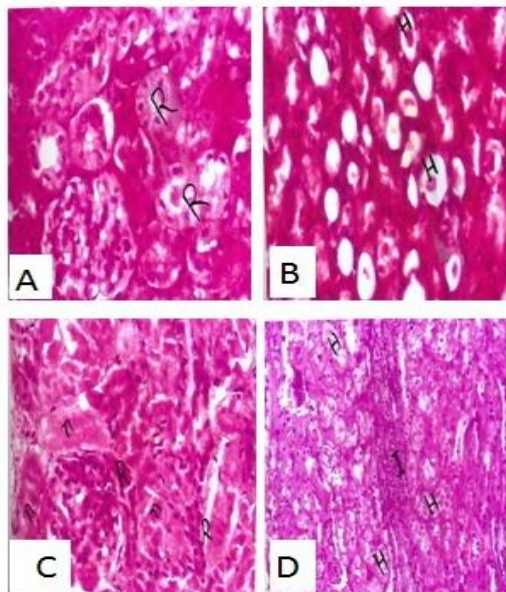
The liver of (G2) after 45 days of treatments showed congestion of central vein, sinusoids and portal blood vessel (Fig.1A). Hepatocytes showed increase in its size with vacuolation of their cytoplasm (Hydropic degeneration), there was midzonal necrosis characterized by deeply eosinophilic cytoplasm, pyknosis of nucleus (Fig.1B). Cholangiofibrosis was detected in the portal areas characterized by proliferation of fibrous connective tissue around portal triad accompanied with mononuclear cells aggregation (Fig.1C). After 90 days of the experiment, the same previous pathological lesions were detected in liver but in sever degree. There were multiple areas of hemorrhage dispersed hepatocytes from each others (Fig.1D). The fibrous connective tissue proliferation extended in-between the hepatic lobules to form periportal cirrhosis (Fig.1E). There were hyperplasia of bile ducts accompanied with infiltration of mononuclear cells mainly macrophages and lymphocytes (Fig.1F). The kidneys of (G2) group after 45 days of the experiment showed different degenerative changes in epithelial lining proximal and distal convoluted renal tubules as hydropic degeneration, renal cast and coagulative necrosis. Renal epithelium appeared enlarged in size with vacuolation of the cytoplasm and even necrosis, (Figs., 2A, 2B and 2C). After 90 days of the experiment, kidneys showed hydropic degeneration in the epithelial lining of most of renal tubules, there was interstitial nephritis characterized by proliferation of fibrous connective tissue and mononuclear cells aggregation mainly macrophages and lymphocytes (Fig.2D).



**Figure 1.**

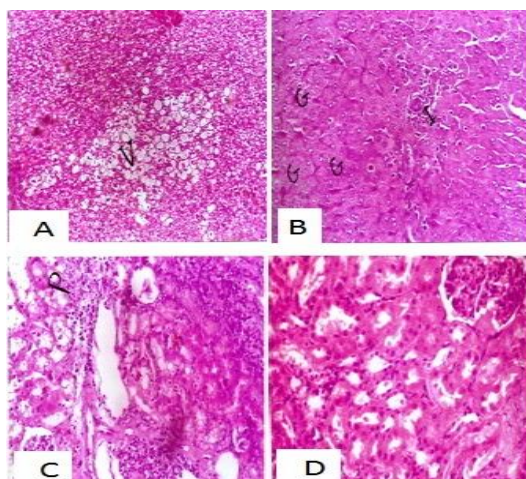
- (1A): Photomicrograph of Liver of rabbits fed aflatoxins contaminated ration and sacrificed at 45 days showing congestion of central vein (C) and sinusoids (S). H&E x100
- (1B): Photomicrograph of Liver of rabbits fed aflatoxins contaminated ration and sacrificed at 45 days showing midzone necrosis and inflammatory cells aggregation (n). H&E x400
- (1C): Photomicrograph of Liver of rabbits fed aflatoxins contaminated ration and sacrificed at 45 days showing cholangiofibrosis (ch). H&E x200
- (1D): Photomicrograph of Liver of rabbits fed aflatoxins contaminated ration and sacrificed at 90 days showing hemorrhagic (H) areas and hydropic degeneration of hepatocytes (h). H&E x200
- (1E): Photomicrograph of Liver of rabbits fed aflatoxins contaminated ration and sacrificed at 90 days showing periportal cirrhosis (C). H&E x100
- (1F): Photomicrograph of Liver of rabbits fed aflatoxins contaminated ration and sacrificed at 90 days showing proliferation of connective tissue between hepatocytes with inflammatory cells (I). H&E x400

The liver of rabbits fed on ration treated with clay (G3) after 45 days of the experiment showed moderate congestion of central vein, sinusoid and portal blood vessel. The hepatocytes were suffered from vacular degeneration of the cytoplasm (moderate hydropic degeneration). There were focal areas of vacular nodules in midzonal area characterized by ballooning of hepatocytes with losing of most of their nuclei (Fig.3A). After 90 days of the experiment, there was slight enlargement of hepatocytes accompanied with granulation of the cytoplasm (cloud swelling). There was mild changes in mononuclear cells aggregation mainly macrophages and lymphocytes were detected in portal triad (Fig.3B). The kidneys after 45 days of the experiment showed moderate congestion of glomerular tuft and renal blood vessels. Some cases showed perivascular cuffing represented by aggregation of lymphocytes around the renal blood vessels (Fig.3C). The kidneys after 90 days of the experiment showed normal histological structure (Fig.3D).



**Figure 2.**

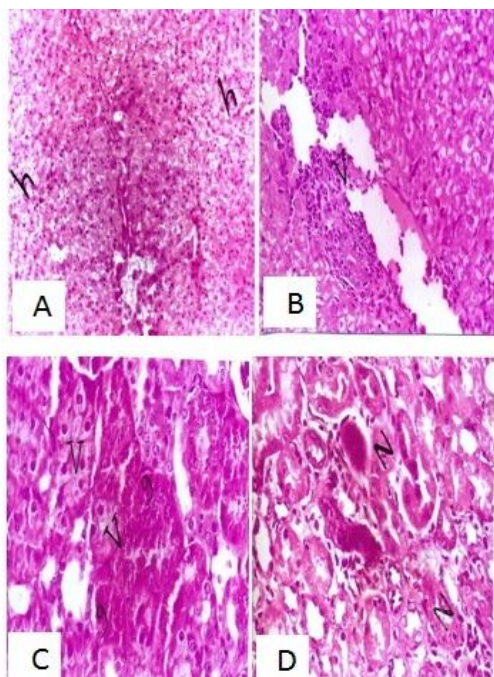
- (2A): Photomicrograph of Kidneys of rabbits fed aflatoxins contaminated ration and sacrificed at 45 days showing enlargement of renal epithelium and vacuolation of its cytoplasm (R). H&E x400
- (2B): Photomicrograph of Kidneys of rabbits fed aflatoxins contaminated ration and sacrificed at 45 days showing hyaline cast in the lumen (H) of most of renal tubules. H&E x400
- (2C): Photomicrograph of Kidneys of rabbits fed aflatoxins contaminated ration and sacrificed at 45 days showing coagulative necrosis of most renal tubules (n). Notice the regenerating tubules (R). H&E x400
- (2D): Photomicrograph of Kidneys of rabbits fed aflatoxins contaminated ration and sacrificed at 90 days showing fibrous connective tissue proliferation accompanied with mononuclear cells aggregation (I). Notice hydropic degeneration of epithelial lining of most renal tubules (H). H&E x200



**Figure 3.**

- (3A): Photomicrograph of Liver of rabbits fed aflatoxins contaminated ration treated with clay and sacrificed at 45 days showing vacuolar nodules (V). H&E x200
- (3B): Photomicrograph of Liver of rabbits fed aflatoxins contaminated ration treated with clay and sacrificed at 90 days showing few inflammatory cells aggregation in portal area (I). Notice the granulation of most of cytoplasm of hepatocytes (G). H&E x200
- (3C): Photomicrograph of Kidneys of rabbits fed aflatoxins contaminated ration treated with clay and sacrificed at 45 days showing perivascular cuffing (P). H&E x200
- (3D): Photomicrograph of Kidneys of rabbits fed aflatoxins contaminated ration treated with clay and sacrificed at 90 days showing normal histological structure. H&E x200

The liver of rabbits fed on ration treated with ammonia (G4) after 45 days of the experiment showed slight enlargement of hepatocytes and mild hydropic degeneration of cytoplasm (Fig.4A). Whereas after 90 days of the experiment the liver blood vessels showed signs of vasculitis represented by desquamation of endothelial lining, mild destruction wall and inflammatory cells aggregation (Fig.4B). The kidneys after 45 days of the experiment showed mild hypercellularity of the glomerular tuft. The epithelial lining of proximal convoluted tubules showed slight degenerative changes as granulation and vacuolation of the cytoplasm with narrowing of their lumen (Fig.4C). After 90 days of the experiment, most of the renal tubules showed slight enlargement of the size of tubular epithelium (Fig.4D).



**Figure 4.**

- (4A): Photomicrograph of Liver of rabbits fed aflatoxins contaminated ration treated with ammonia and sacrificed at 45 days showing mild hydropic degeneration of hepatocytes (h). H&E x100
- (4B): Photomicrograph of Liver of rabbits fed aflatoxins contaminated ration treated with ammonia and sacrificed at 90 days showing vasculitis and rupture of portal blood vessels (V). H&E x200
- (4C): Photomicrograph of Kidneys of rabbits fed aflatoxins contaminated ration treated with ammonia and sacrificed at 45 days showing granulation (g) and vacuolation of cytoplasm of epithelial lining of the renal tubules (V). H&E x400
- (4D): Photomicrograph of Kidneys of rabbits fed aflatoxins contaminated ration treated with ammonia and sacrificed at 90 days showing enlargement of the nucleus of some epithelial lining of the renal tubules (N). H&E x400

#### 4. Discussion

In the present study, the effect of clay and ammonia on aflatoxin contaminated ration had been studied on rabbits. The average daily body gain of rabbits fed aflatoxin contaminated ration was linearly decreased with the advance of the feeding period. The decrease in body weight was associated with decline in the average of daily feed intake. Feed intake may have been depressed as a result of decreased palatability of aflatoxin contaminated ration. In addition, aflatoxins impair nitrogen and energy utilization on the ingested diet through its

adverse affects on the liver, as it is considered as the center of body metabolism (Reddy *et al.*, 1991).

In the present study, seven rabbits fed aflatoxin contaminated ration were died through the experimental period. This could indicate a sign of chronic aflatoxicosis in rabbits fed contaminated ration with aflatoxin. The obtained results are agreed with Nowar *et al.* (2001) they noticed a reduction in average of live body weight and gain of rabbit fed diet naturally contaminated with 860 ppb aflatoxins. When aflatoxin ration treated with clay (2%) (bentonite), the performance of rabbits were

improved, this could be explained by the basic mechanism of bentonite and the adsorbents in preventing the aflatoxin toxicity, it appears to involve sequestration of aflatoxin in gastrointestinal tract and chemisorptions to the adsorbent, which reduces the bioavailability of aflatoxins (Davidson *et al.*, 1987 ; Lindemann *et al.*, 1993 and Mahendra *et al.*, 2012). The effect of ammonia treatment of aflatoxin contaminated rations in improving animal performance could be due to the effect of ammonia releases as alkaline compound on preventing the production of aflatoxicosis by fungi and verified the conversion of B1 aflatoxin (more toxic) to D1 aflatoxin (non toxic) (Southern and Clawson, 1980 ; Norred, 1982; Fayed, 1999 and Mahendra *et al.*, 2012).

The increase in relative weight of organs (liver and kidneys) of rabbits fed aflatoxin contaminated ration was reported in this study, this result was agreed with Nowar *et al.* (1996 and 2001) they explained that the relative weight of internal organs could be a result of increased lipids in the liver which associated with harmful effect of aflatoxin. However, the improvement in relative weight of internal organs of rabbits fed aflatoxin contaminated ration treated with clay, could be due to the protection effect of bentonite against aflatoxin (Nowar *et al.*, 2000 and 2001; Bailey *et al.*, 2006 and Dixon *et al.*, 2008) and the alkaline effect of ammonia treatment on depressing the growing of fungi which reflect on less production of aflatoxin (Jones *et al.*, 1996; Fayed, 1999 and Mahendra *et al.*, 2012).

Aflatoxin B1 is one of the most common mycotoxin and it is a potent hepatoxins and hepatocarcinogen. The liver histopathological results observed in this study could be due to the metabolism of aflatoxins occurs in liver by cytochrom P450 enzyme. In the liver cell, aflatoxins converted to classes of metabolites which bound to cellular macromolecules such as essential enzymes blockages of RNA polymerase and ribosomal translocase and formation of DNA adduct. Aflatoxins can bind to various proteins which may affect structural and enzymatic protein functions. Also, aflatoxins and their metabolite are mainly secreted by bile, so this explains the pathological lesions observed in bile duct (Hsieh, 1985; Hsieh and Atkinson, 1990 and Leesson *et al.*, 1995). Although the kidney was not the target organ for the effect of aflatoxins; there were histopathological changes recorded in this study. Aflatoxin and its metabolite can be excreted via the kidneys producing damage to kidney's tissue (Leesson *et al.*, 1995 and Agag, 2004). Histopathological changes were showed in liver of rabbits fed aflatoxin contaminated ration treated with clay after 45 and 90 days of the experiment, whereas

kidneys after 45 days showed a mild to moderate histopathological severity. While the kidneys after 90 days of the experiment showed normal histological structure. Histopathological changes which occurred in liver and kidneys at 45 and 90 days period of rabbits fed contaminated ration treated with ammonia are considered as mild changes and reversible. The histopathological findings clearly indicated that the addition of clay or ammonia to aflatoxins contaminated ration greatly diminished the deleterious effect of aflatoxicosis on liver and kidneys (Jones *et al.*, 1996; Fayed, 1999; Nowar *et al.*, 2001 and Mahendra *et al.*, 2012).

So, it can be concluded from this study, that aflatoxin contaminated ration treated with either clay 2% (G3) or ammonia 1% (G4) had proven to be the best detoxification methods. However, ammonia treatment can be recommended as a cheapest way to inhibit the fungus growth and can effectively detoxify aflatoxin in animal feeds. Clay (bentonite) at the rate of 2% could be also another cheap way for the detoxification of aflatoxin effect by adsorption of it from gastrointestinal tract of animals on the surface of the bentonite layers, consequently prevent the bioavailability of aflatoxin.

#### Corresponding Author:

**Dr. Ahmed Abdel Aziz<sup>1,2</sup>**

<sup>1</sup>Medical Biotechnology Department, Faculty of Applied Medical Sciences, Taif University, KSA

<sup>2</sup>Zoology Department, Faculty of Science, Cairo University, Egypt

[Aabdelaziz.baiomy@gmail.com](mailto:Aabdelaziz.baiomy@gmail.com)

#### References

1. Abdelhamid, A. M.; Sadik, E. A. and Fayzalla, E. A. Preserving power of some additives against fungal invasion and mycotoxin production in stored-crushed-corn containing different levels of moisture. *Acta phytopathologica Academic Scientiarum Hungaricae*, 1985; 20: 309.
2. Agag, B. I. Mycotoxins in food and feeds. 1- Aflatoxins. *Ass. Univ. Bull. Environ. Res.*, 2004; 7(1): 173-206.
3. Asi, M. R.; Iqbal, S. Z.; Arino, A. and Hussain, A. Effect of seasonal variations and lactation times on aflatoxin M1 contamination in milk of different species from Punjab, Pakistan. *Food Control*, 2012; 45(1): 34–38.
4. Bailey, C.A.; Latimer, G.W.; Barr, A.C.; Wigle, W.L.; Haq, A.U.; Balthrop, J.E. and Kubena, L.F. Efficacy of montmorillonite clay for protecting full-term broilers from aflatoxicosis. *J. Appl. Poult. Res.*, 2006; 15: 198-206.
5. Bancroft, J. and Cook, H. *Manual of*

- histological technique 3<sup>rd</sup> Ed Churchill, Livingston, London, New York. 1994.
6. Brekke, O. L.; Peplinski, A. J. and Lancaster, E. B. Aflatoxin inactivation in corn by aqua ammonia. *Trans. Am. Soc. Agric. Eng.*, 1977; 20(6): 1160- 1166.
  7. Daniel, M. R. *In vitro* assay systems for aflatoxin. *Br. J. Exp. Path.*, 1965; 46: 183.
  8. Davidson, J. N.; Babish, J. G.; Delaney, K. A.; Taylor, D. R. and Phillips, T. D. Hydrated sodium calcium aluminosilicate decreases the bioavailability of aflatoxin in the chicken, *J. Poult. Sci.*, 1987; 66(Supp1-1): 89 (Abstr.).
  9. Diekman, M. A. and Green, M. L. Mycotoxins and reproduction in domestic livestock. *J. Anim. Sci.*, 1992; 70 (5): 1615-1627.
  10. Dixon, J.B.; Kannevischer, M.G. and Barrientos, V.A. Aflatoxin sequestration in animal feeds by quality-labeled smectite clays: an introduction plan. *Appl. Clay Sci.*, 2008;40:201-208.
  11. Eaton, L. D. and Gallagher, E. P. (1994). Mechanism of aflatoxin carcinogenesis, *Ann. Rev. Pharmacol Toxicol.*, 34: 135-172.
  12. Fayed, A. M. Ammoniation of the contaminated crop residues with aflatoxins and its effect on rabbits. M.Sc. Thesis, Fac. Sci. Cairo Univ., Egypt. 1999.
  13. Hsieh, D. P. H. An assessment of liver cancer risk posed by AFM1 in western world. In: Lacey, J. (ED.), *Trichothecenes and other mycotoxins*. Wiley and sons, Chichester, 1985; 521-527.
  14. Hsieh, D. P. H. and Atkinson, D. N. Biological reactive intermediates and carcinogenicity. Plenum Press, New York, 1990; 525-532.
  15. Huff, W. E.; Kubena, L. F.; Harvey, R. B.; Corrier, D. E. and Molenhauer, H. H. Progression of aflatoxicosis in broiler chickens. *J. Poult. Sci.*, 1986;65:1891.
  16. János, V.; Sándor, K.; Zsanett, P.; Csaba, V. and Beáta, T. Chemical, Physical and Biological Approaches to Prevent Ochratoxin Induced Toxicoses in Humans and Animals. *Toxins*, 2010; 2: 1718-1750.
  17. Jones, F. T.; Wineland, M. J.; Parsons, J. T. and Hagler, W. M. Degradation of aflatoxin by poultry litter. *Poult. Sci.*, 1996; 75: 52-58.
  18. Kececi, T.; Oguz, H.; Kutoglu, V. and Demet, O. Effect of polyvinyl polypyrrolidone. Synthetic zeolite and bentonite on serum biochemical and hematological characters of broiler chickens during aflatoxicosis. *British Poult. Sci.*, 1998; 39: 452-458.
  19. Leesson, S.; Diaz, G. and Summers, J. D. Aflatoxins, in: Leesson, S. Diaz, G. and Summers, J. D. (EDs). *Poultry metabolic disorders and mycotoxins*. Guelph, Canada, University Books. 1995;248-279.
  20. Lindemann, M. D.; Biodgett, D. J.; Kernegay, E. T. and Schurig, G. G. Potential ameliorators of aflatoxicosis in weaning growing swine. *J. Anim. Sci.*, 1993; 71: 171-178.
  21. Magnoli, A.P.; Tallone, L.; Rosa, C.A.; Daclero, A.M.; Chiaacchiera, S.M. and Torres, S.R. Commercial bentonites as detoxifier of broiler feed contaminated with aflatoxin. *Appl. Clay Sci.*, 2008;40:63-71.
  22. Mahendra, K.; Shital, R.; Avinash, P. and Aniket, K. Mycotoxin: rapid detection, differentiation and safety. *J. Pharm. Educ. Res.*, 2012;3(1).
  23. Moorthy, A.S.; Mahender, M. and Rama Rao, p. Hepatopathology in experimental aflatoxicosis in chickens. *Indian J. Anim. Sci.*, 1985; 55: 6929.
  24. Norred, W. P. Ammonia treatment to destroy aflatoxins in corn. *J. Food Prot.*, 1982; 45(10): 972-976.
  25. Norred, W. P. Animal testing procedures in assessing the efficacy of ammoniation commodities. In: *Aperspective on aflatoxin in field crops and Animal food products in the United States: National Technical Information services*, Spring field, Virginia. 1990; 120-126.
  26. Nowar, M. S. and Abd El-Mageed, F. A. New simple approach for quick prevention or minimizing acute aflatoxicosis by adding soil to ration. 36<sup>th</sup> Festival of week science. University of Halab, Syria, 1996.
  27. Nowar, M. S.; Abdel-Rahim, M. I.; El-Gaafary, M. N.; Ibrahim, Z. A. and Abdallah, F. R. Aflatoxicosis in rabbits: 3- Effectiveness of Egyptian raw bentonite in prevention or diminution of the detrimental effects of aflatoxins naturally contaminated diets on reproductive performance, blood biochemistry and digestibility in rabbits. 5<sup>th</sup> Scientific Vet. Med. Conf., 12-14 Sep. Sharm El-Sheikh. Egypt. 2000; 321.
  28. Nowar, M. S.; Abdel-Rahim, M. I.; Tawfeek, M. I. and Ibrahim, Z. A. Effect of various levels of Egyptian raw bentonite on detoxification of rabbits diet naturally contaminated with aflatoxins. *Egyptian J. Nutrition and Feeds*, 2001; 845-860.
  29. N.R.C. National research council, nutrient requirements of domestic animals. Nutrient requirements of rabbits, Washington, D.C., 1977.
  30. Oguz, H. The preventive efficacy of polyvinylpyrrolidone alone and its combination

- with the other adsorbents into broiler feeds against aflatoxicosis. Ph.D. Thesis (University of Selcuk. Institute of Health Sciences, Konya). 1997.
31. Oliver, M. D. Effect of feeding clinoptilolite (Zeolite) on the performance of 3 strains of laying hens. *British Poult. Sci.*, 1997; 38: 220-222.
  32. Pfohl-Leszkowicz, A.; Manderville, R.A. Ochratoxin A: an overview on toxicity and carcinogenicity in animals and humans. *Mol. Nutr. Food Res.*, 2007; 51, 61-99.
  33. Phillips, T. D.; Clement, B. A.; Kubena, L. F. and Harvey, R. B. Detection and detoxification of aflatoxins: Prevention of aflatoxicosis and aflatoxin residues with hydrated sodium calcium aluminosilicate. *Vet. Human Toxicol.*, 1990; 32: 15-19.
  34. Pier, A. C. Major biological consequences of aflatoxicosis in animal production. *J. Anim. Sci.*, 1992; 70: 3944-3967.
  35. Reddy, R. S.; Rao, P. V. and Reddy, V. R. Effect of dietary aflatoxin on protein quality and metabolizability of energy in chickens. *Indian J. Anim. Sci.*, 1991; 16: 1132-1135.
  36. Rodgers, A.; Vaughan, P.; Prentice, T.; Edejer, T.; Evans, D.; Lowe, J. Reducing risks, promoting healthy life. In: Campanini B, Haden A, eds. *The World Health Report*. Geneva: World Health Organization, 2002.
  37. SAS SAS user's guide: Statistics. SAS Inst., Inc Cary, NC Raleigh. 1998.
  38. Schell, T. C.; Linemann, M. D.; Kornegay, E. T. and Blodgett, D. J. Effects of feeding aflatoxin contaminated diets with and without clay to weanling and growing pigs on performance, liver function and mineral metabolism. *J. Anim. Sci.*, 1993; 71: 1209-1218.
  39. Sharon, W.; Wyatt, R. D. and Hamilton, P. B. Improved yield of aflatoxin by incremental increase of temperature. *Appl. Microbiol.*, 1973; 26: 1018-1019.
  40. Shotwell, O. L.; Hesseltine, C. V.; Stubblefield, R. D. and Sorenson, W. G. Production of aflatoxin on rice. *Appl. Microbiol.*, 1966; 14: 425-429.
  41. Somorin, Y. M.; Bertuzzi, T.; Battilani, P. and Pietri, A. Aflatoxin and fumonisin contamination of yam flour from markets in Nigeria. *Food Control*, 2012;25(1):53-58.
  42. Southern, L. L. and Clawson, A. J. Ammoniation of corn contaminated with aflatoxin and its effects on growing rats. *J. Anim. Sci.*, 1980; 50: 459-466.
  43. Sundstol, F.; Coxworth, E. and Mowat, D. N. Improving the nutritive value of straw and other low quality roughages by treatment with ammonia. *Wld. Anim. Rev.*, 1978; 26: 13-21.
  44. Theumer MG, Lo'pez AG, Masih DT, Chulze SN, Rubinstein, HR. Immunobiological effects of AFB1 and AFB1-FB1 mixture in experimental subchronic mycotoxicoses in rats. *Toxicology*, 2003;186:159-70.
  45. Wood, G. E. Aflatoxins in domestic and imported foods and feeds. *J. Assoc. Offic. Anal. Chem.*, 1989;72: 543-548.
  46. Zuckerman, A. J.; Tsiquaye, K. N. and Fulton, F. Tissue culture of human embryo liver cells and the cytotoxicity of aflatoxin B1. *Br. J. Exp. Path.*, 1967;48: 20-21.

9/2/2012



## Use of Waves and Tide Energy for Production Electricity in Iran

Nafiseh Ghorbani<sup>1</sup>, Amrollah Moradi<sup>1</sup>, Heidar Abdollahian<sup>1</sup> and Mohammad Ranjbar Kohan<sup>2</sup>

<sup>1</sup> Department of Technical Drawing, Shahr-e-rey Branch, Islamic Azad University, Shahr-e-rey, Tehran, Iran

<sup>2</sup> Department of Mechanical Engineering, Buinzahra branch, Islamic Azad University, Buinzahra, Iran

**Corresponding Author:** Mohammad Ranjbar Kohan, Department of Mechanical Engineering, Buinzahra branch, Islamic Azad University, Buinzahra, Iran, Email: [RanjbarKohan@gmail.com](mailto:RanjbarKohan@gmail.com)

**Abstract:** Fossil source limits, augmenter expansion of the energy demand and most importantly the catastrophe of environmental pollution resulting from the burning of fossil materials have caused the science to apply natured recoverable energies. One of the sources of recoverable energies is the tides and the other is wave energy. Existence of long sea borders in Iran, have turned the mentioned country to one of the potentials in the region to use energy from the sea. In this article beside the examination of the methods to acquire energy from the sea, the already-done measures related to this issue are also considered and evaluated.

[Nafiseh Ghorbani, Amrollah Moradi, Heidar Abdollahian and Mohammad Ranjbar Kohan. **Use of Waves and Tide Energy for Production Electricity in Iran.** Life Sci J 2012;9(3):2722-2725] (ISSN:1097-8135). <http://www.lifesciencesite.com>. 396

**Key words:** fossil source – pollution – waves and tide energy – Iran

### 1- Introduction

Fossil source limits, augmenter expansion of the energy demand and most importantly the catastrophe of environmental pollution resulting from the burning of fossil materials have caused the science to apply natured recoverable energies [3].

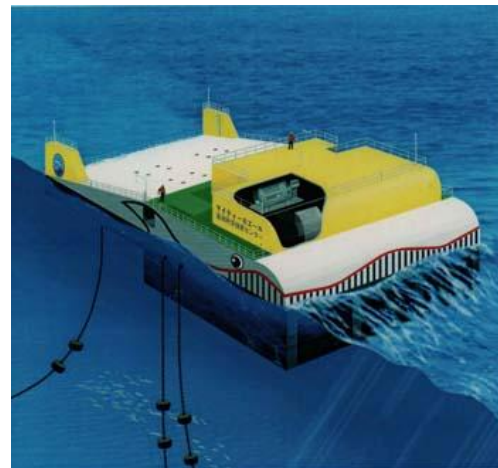
Marine or decanis energy, is one of the recoverable energies alongside solar and wind energies which has been considered. Waves energy and tides energy can be counted the two major marine energies. The reason why the development of these energies have been independent is in their various features and different methods to attract them [4, 5].

The tidal power planets for their similarity to water power plants and using their prepared technology have achieved quick progresses. But changes and basic alternations in the procedure is necessarily needed because of the environmental problems.

### 2- Kinds of Waves and Tidal Power Planets

Waves and tidal power planets have a lot of types; some are floating on the water and some are installed on the seashore. There is also a difference

in their involvement with the waves and following it the move they attract. In addition to the researches, some small samples of wave systems are built all over world and experimented upon. Figure 1 is showing a schematic of a wave power plant [5].



**Figure1,** A Schematic from Tidal Power Plants

The transition of energy from the wind to the sea creates the waves. The rate of this transition depends on the speed of the wind and also the distance which the wind had had interplay with the surface of the water. The waves carry potential energy because of the water weight transition in

regard to the intermediate sea level and carry kinetic energy for the speed of water particles. The restored energy wastes via friction, turbulence and the severest. Which depends on the waves properties and the water depth. The big waves lose their energy in the dept waters too slowly. The system/model of waves is complicated and almost often originates from local winds and the storms which wave brewed in the far distance. The waves are specified from their heights, lengths and intermittences.

Waves power is stated on the basic of kilowatt/meter which indicates the transition strength or the traverse of the energy from an imaginary line with the length of one meter and parallel to wave front. Nowadays the technology of producing energy from the oceans waves is invented and over 400 inventions are registered [5].

### 2-1 Using the Waves Energy

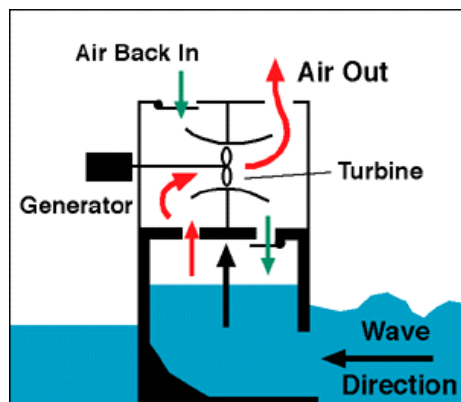
Three designs of waves energy are applied to conserve the energy [1, 2]:

#### Using Floating Columns

The mobile waves of the ocean pass kinetic energy. The mentioned energy can be applied to rotate a turbine. Figure 2 is showing a simple schematic of such energy switch. As shown in the picture the wave goes up in the column/capsule and it causes the air exist from the other side.

Then the moving air helps the turbine rotate which results in the rotation/operation of the generator.

When the waves go down, the air flows through turbine and once again enter the capsule through doors that are usually closed. This is, merely, one of the waves' energy producing systems.



**Figure 2,** Schematic Image of a Wave Turbine with the Help of Floating Cylinders

### Using Floating Cams

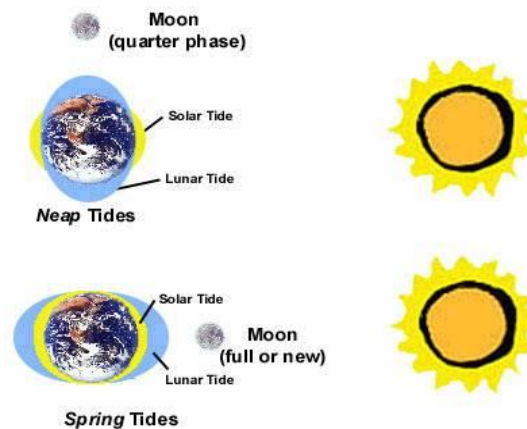
When the tide comes up, it will turn the cams and this turning movement connects to the generator. In fact the waves connect a big number of the cams together by a rod and put the device on the waves near the shores. These systems are useful for heavy waves.

### Using the Drum Islands of the Drum System

It is something like an automobile tube whose rims are flexible and a turbine has been installed into the internal parts of the distributing compartments. This system is thrown into water floating around and the waves hit it. This strike hits the tube's rim and causes depression. The depression causes the condensation of the internal air. As a result, the condensed air enters a capsule from another capsule and causes the turbines to turn.

### 2-2 Using the Tides Energy

The sea's tides are created as a result of the moon and the sun's gravity as the earth turns. The moon's force of gravity causes the water to rise up and as a result of the earth's situational circulation, this rising flows towards the west. Consequently, waves will be created at the intervals of 12 hours and 25 minutes whose flexibility scope in the big oceans is about 0.5 meters. The effect of the sun's force of gravity is similar, but weaker and it appears once every 12 hours [5].



**Figure 3,** Schematic Condition of Creation of Tides

Thus, tides take place regularly in the shape of lunar waves. The highest scope of waves happen when the sun and the moon are in the same direction and the lowest takes place when they are not in the same direction. When the tidal waves

reach the continent's shores, their scope can increase the creation of resonance considerably as a result of the rush of water and the funneling of the waterway. For example, the scope of tides at appropriate places in Canada reaches as high as 10 meters. Despite the specific complications that exist in the tides, the precise anticipation and calculation in every place is possible [1, 2].

Seeking energy from the tides is practical in places where a lot of energy is concentrated in them as big tides and furthermore, the location's geography has also created a suitable site for the installation of tidal reactors. Such places can not be found everywhere. However, so far, a relatively high number of them have been identified. For the time being, few tidal reactors have been installed in the world. The first and the biggest of them is a type of single-pool and it has two effects. One with the 240

megawatt capacity has been installed in Lawrence, France which is commercial. Other than that one, the 20 megawatt reactor in Annapolis, Canada and the 400 kilowatt reactor located in Kislaygoba in the old Soviet Union and 3.2 megawatt reactor located in Jiangezia, China can be mentioned. There are also a few multi-purpose stations located in China [1, 2]. Figure 4 shows one of the methods of taking advantage of the tides energy.

When the water rises on one end of the reactor as a result of reflux causes the water to pass through the turbines and turn them. The turning of the turbines causes the generator to turn on and generate electricity.

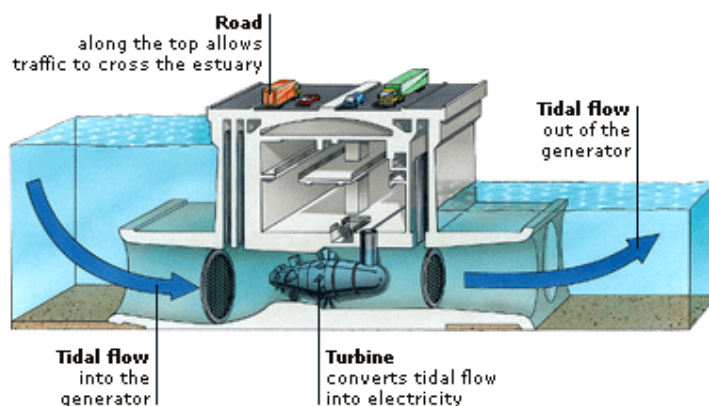


Figure 4, Shows One of the Methods of Using the Energy of Flux and Reflux

### 3- Projects Which Are in Process of Execution in Iran

#### 3-1 Manufacturing Laboratory Models for Changing the Sea's Waves into Energy

This project started in 1996 and ended in 1999. The conductor of this project was Iran's New Energy Institute and the testing site was Tehran. During this project, designing and manufacturing of laboratory models for changing the sea waves' energy were tested. Coming along with the exploitation technology by taking advantage of the sea's wave around the world was researched [5].

#### 3-2 Manufacturing an Apparatus for the Absorption of Energy from the Sea's Waves in Iran

This project was accomplished by an Iranian inventor and the assembled apparatus included a

main body and a number of arms and also a gearbox that turned linear movements of the arms into circular movements and the power of the manufactured sample was one kilowatt. The capability of doing the task in the vicinity of the waves' height was from short to tall and the regular and irregular waves were some of the advantages of this device [5].

Except for two mentioned cases, other researches and studies are being conducted in the form students' theses and other related projects. Among them, we can refer to the analysis of potential production of energy from the waves in the Persian Gulf region and the Oman Sea and or the simulation of the waves' motion on the sea and the effective factors [5].

#### 4- Conclusion

Following the evaluation of potential studies and the possibilities of manufacturing waves and flux and reflux reactors taking into account the very high costs of operating them and their technical difficulties for which the resources cannot be justified, the accomplished activities in Iran are, merely, about the researches and, so far, no reactor has been operated for producing energy by the help of waves' energy in Iran.

We hope that as the technology advances, methods with higher efficiencies will provide the necessary conditions for building reactors in the field.

#### 5- References

[1] Energy Information Administration (EIA) of the Department of Energy, "Annual Energy Outlook 2003 with Projections to 2025", 2003. <http://www.eia.doe.gov/>, <http://www.eia.doe.gov/oiaf/aeo/index.html> 9.10.2003.

[2] Energy Information Administration (EIA) of the Department of Energy, "Annual Energy Outlook 2003 with Projections to 2025", 2003. <http://www.eia.doe.gov/oiaf/aeo/assumption/download.html>, [http://www.eia.doe.gov/oiaf/aeo/assumption/pdf/0554\(2003\).pdf](http://www.eia.doe.gov/oiaf/aeo/assumption/pdf/0554(2003).pdf) 9.10.2003

[3] Ghobadian, B., Najafi, Gh., Rahimi, H. and Yusaf, T.F. (2008) Future of renewable energies in Iran, *Renewable and sustainable energy reviews*, xxx, pp. xxx-xxx.

[4] H Vakil, GE Global Research Center, Schenectady, NY. Subject: Capital Costs and Efficiencies of Gas Turbines. Personal communication to W. Edelstein.

[5] [WWW.SUNA.ir](http://WWW.SUNA.ir) (Wind office-Renewable Energies Office-Ministry of Energy-Islamic Republic of Iran).

11/4/2012

## The theory of mind in terms of Sheykh Ishraq:

**Zeinab Sagvand**

Technical University of Country

Teacher of Girls Technical college of Khoramabad, Khoramabad, Iran

**Abstract:** In this paper we tried to study Sheykh Ishraq's view on knowledge. Although Suhrawardi's views on epistemology system considers wisdom and intuition as the knowledge tools, in this view there is deep stuff which must be studied in this manner, including Ishraqi's style which is actually conscience perceiving and mystic examination. Ishraqi's philosophy aimed to get the facts by experiencing not by rational reception and acclaiming by long-distance.

[Zeinab Sagvand. **The theory of mind in terms of Sheykh Ishraq.** *Life Sci J* 2012;9(3):2726-2729] (ISSN:1097-8135). <http://www.lifesciencesite.com>. 397

**Keywords:** idealism, origin reason rational intuition, Seir-o-solook, ontology, knowledge through feeling.

### Introduction:

In Sheykh Ishraqi's epistemology, origin and final reason aren't the way through which human can discover the reality, and if the ladder of logic is short, mystical intuition and esoteric perceptions and physical science will continue idealism and seek for truth and reality. To Sheykh, the necessity of his knowledge is moving towards Kingdom of God which obtained through scientific and abstraction, and the condition for entering the Kingdom of God is abstraction and deposition the body. Indeed, in Sheykh's philosophical system, one of the truth-seeking implements is abstraction. So human can, by deposition his body and gaining abstraction state, get to the abstraction light and benefit of it. Accordingly, since abstraction is the main condition of entering to the light universe and discovering the facts, Sheykh in his philosophy has masterfully changed the entering way of abstraction and light universe in the axis of humanity and joined it in a point called self-knowledge.

In Ishraq's philosophy system self-knowledge is the center of all talented learning and the axis of all problems reason and transportation sciences and the basis of all charities and prosperities.

In Sheykh's epistemology realm what is right and is of genuineness is the fact of objects in the Kingdom of God which are truth. So, human in order to reach fact and discover the facts requires some objects of abstraction class, and realizes it as a talent. In fact, for him understanding the facts is as experiencing which includes getting to destination. He believes that it should be united with the essence of wisdom and scientific forms of donor, which population denominators is from flaw up to perfection, then Sheykh prepares and arms himself by the wings of science and reason for human not to fail in his discoveries, and measures whatever he has discovered, believed and felt by means of argumentative benchmarks. To Sheykh it is also not enough and uses another safe criterion of

discovering to self-purification and also uses Jihad field in his book Al-Mashare' which is the interpretation of formal science and illumination philosophy. In response to a problem he explains that formal knowledge is obtained through realizing and perceiving known scientific form. So, the subjective known must match and be identical with the external object.

### Sheykh Ishraq's views on theory of knowledge:

Abolfath Yahya ibn Habash Suhrawardi in the Islamic universe and philosophy of wisdom does not need to be introduced. Suhrawardi's philosophical system despite many exile and nostalgia is one of the most important systems in Islamic philosophic systems which is strongly influenced by Platonic and neo-Platonic and Fahlavi philosophy, in exchange for this sad and influence Suhrawardi has a remarkable effect in his later philosophy, i.e., Transcendent philosophy. In Suhrawardi's epistemology, reason and intuition, both are of originality and the two instruments can be used to identify things.

In his epistemology, the origin and final reasons are not the course of truth-seeking for human and if the ladder of logic is short intuition and esoteric (inward) perceptions and physical science (Ilm-e-huduri; knowledge by presence) will continue the course of truth-seeking and idealism, in fact intuition is one of the knowledge tools, as the reason and sense. Wisdom uses intuition itself. If wisdom copies or uses the sense perceptions, the lowest of powers, now cannot it copy heart and intuition? In Suhrawardi's philosophy, wisdom is accepted as far as not go beyond its limits in the knowledge and its limits be observed and not be greedy in the comments beyond his understanding power. Due to the limitations of reason, we can never consider it as the only means of knowledge infinite beings including God.

And so, discussions about talents (chimerical) in Ishraqi's philosophy are of importance. Sheikh Ishraq in

his epistemology respects and reverences intellects and wisdom and for him deprived of intellect and wisdom is as a defect and failure.

Sheykh believes that in the wise man, mind and heart must be in agreement with each other, and what is in speech should be consistent with what is going on the mind that is he believes that thought and intuition should be synchronized with each other. For Suhrawardi, it is possible to think about intuitive knowledge, and obtained the facts thoughtfully by evident combination.

In this case thought with heart and gaining knowledge with intuition will be in harmony.

That is we can intuitively think of theoretical thought in terms of intuitive sciences and can understand the intuitive theoretically and objectively.

For Suhrawardi wise is a person who gets the facts by any way whether intellect or by the heart. So that he finds a mystic who is of right wisdom. Therefore the absolute discursive intellect is not the way of getting to right wisdom. What is needed in philosophy is utilizing the absolute reason either discursive intellect or wisdom derived from intuition but Suhrawardi prefers intuitive wisdom. Accordingly Suhrawardi defines philosophy on the basis of its ends through which fact is obtained. To his vision, pure spirituality, due to its purpose, is the same as philosophy, and mystics (Sufis) are the true scholars.

In sheikh Ishraq's school reason and intuition are another ways because both talent and wisdom ways are open to each other. Hence it must be admitted that intuition and intellect are not opposites.

Sheikh claims that he can argue about his intuition and implement these two tools. He believes that intuition and wisdom aren't against each other. He acknowledges this in his Kitab Talvihah and hikmat-al-ishraq (the intimations and illumination philosophy)

And so similarity to right is the way of eternal bliss and happiness, i.e., man is the greatest manifestation of the self-existent.

Suhrawardi's epistemology, although considers wisdom and intuition as the knowledge tools but this view there is deep stuff which must be studied in this manner, including Ishraqi's style which is actually conscience perception and mystic examination. His philosophy aimed to get the facts through experiencing and getting to Kingdom of God not through rational perceptions and calling from long-distance; in this respect what can help man to reach the facts are two: first expertise in forensic science i.e., theoretical reason and secondary the way of self-discovery to collect abstraction and entering into the world of facts. For Suhrawardi, since the facts of objects are in the world of Anwar (Lights) so in order to get the facts we must enter to their world, and the condition of entering is self-knowledge deposition of body and abstraction. Prof. Dinani in his book "arrays

of thought and intuition" on Suhrawardi's philosophy writes:

"This illumination philosopher, although finds the basis of wisdom on the abstraction science associating with intuitive knowledge, he also relies on argument and considers it as the criteria of affairs. He warned his audience from any duplication, and says with great emphasis that: "copy neither me nor anyone else in any way", because the diagnostic criteria are in the proof of state.

As it can be seen in the words, Suhrawardi made an essential emphasis on argument and considered it as the state criteria. So, we can claim that according to him, Illumination philosophy was based on thought and intuition, and Sages' grades are evaluated and classified based on these two factors.

According to his view, Seir-o-solok, self-illumination, and thoughts and recollections of God are arranged in reasonable manner, and sufficient truth is getting through the real perceptions and corresponding to God.

He writes in his book "Bostan al-Qoloub":

"Thought is after praying and recollection". Praying and recollection is of great importance and influence, and the Lord is always good and acceptable to you. When the prophet Muhammad has come and introduced by Gabrael, most intellects did not believe it and said that when Gabrael comes, brings Qur'an with himself.

In Sheykh's epistemology field, what is right and authenticity and the truth of objects is in the Kingdom of God which is facts. So, human needs some tools of abstractive type to get and collect facts and discover truths which finds it as a talent. In fact, to him everybody should experience it to understand the facts such as approaching to God. He believes that nature and essence of wisdom and scientific forms of donor must be united which population denominators is from defect to perfection, so Sheykh prepares himself with knowledge and proof to help to man not do any errors in his discovery and evaluate whatever he has discovered and experienced but to Sheykh it is not enough, and for him, another measure of the safe discovery is self-purification, thinking of God and Jihad (Tajahod). In Sheykh's epistemology, man as a microcosm, and as the comprehensive and concise description of the realms, is a being that can move towards universe by self-knowledge and self-realization, and be in the ascending course of the universe which is in correspondence with outside and external world. In fact, self-knowledge in illumination philosophy is as an interface segment between man and the Kingdom of God which is the entry way for man into Kingdom of God and real and scientific forms of objects and self-knowledge is a short and close way that man can enter it by thinking and recalling God, and by self-discovery realizing the conscience can get to self-reality, and reality of

testimony world, so we can get to their reality through this knowledge.

### **The priority of epistemology or ontology:**

As it was mentioned, although emphasizing to epistemology for the pioneers of new philosophy is evident, the history of priority of epistemology problems over ontology topics belongs to Kaant's philosophy. Many intellects after Kaant influenced by this and even some of contemporary Muslim scholars prefer epistemology logically, that is why in order to comment about existence issues we must discuss in the beginning about identification, so that commenting about reality requires comment about identification. But, there are some people against this who believe that ontology proceeds epistemology. To justify this view, some points noted here:

1. Natural state of mind considers the fact and mind only considers the quality of identifying the truth when it ignores the reality indirectly.

2. In contrary, a counterpoint reason that documents it, we can say that whatever we say about knowledge and recognition requires a theory of reality and existence. That is as far as there is no viewpoint about the self-reality any theory about knowledge will be senseless.

3. In the theory of those who believe in the priority of epistemology, it is possible to find a kind of priority for the theory of ontology, for example Dekart's view on knowledge and technique based on "I think, so I am" and that is a theory about universe. Also, indeed there is a theory about emergent distinction and per se object which is actually a theory concerning ontology, because knowledge itself is one of the realities of universe.

So, it seems that we should not easily submit to the viewpoint of the priority of epistemology over ontology, and note that these two topics are strongly associated with each other: "we should note that the distinction between these two topics and differentiating them, such that some of contemporary philosophers take pride in it, it is important for those who know that it is impossible to ignore these two topics from each other, in such a case this view would be virtual and baseless."

So, it should be noted that separating the topics on ontology from those of epistemology is difficult and probably not correct.

### **Levels of knowledge:**

The first point that should be noted in the studying of Suhrawardi's views about knowledge is that for him knowledge limited not to an order. Thus he considers some types of knowledge that form the hierarchy. He divides the knowledge into acquiring or gaining knowledge and knowledge of presence.

In the knowledge of presence which is noted by the changes of illumination, association, intuitive and talent knowledge, the Known is indirectly and immediately

recognized. But in the acquiring or gaining science, also named formal science, is an intermediate in the work which if the intermediate is a form of senses it is called "intuitive knowledge", and if it is conceptual, logical or discursive it is called "rational knowledge".

### **Formal and illuminative science:**

Suhrawardi uses some versions of formal and illuminating sciences in Al-Mashare', and in order to response to a problem explains that formal science is obtained over the acquiring and perceiving of known scientific form and there should be a compatibility between the subjective and the external object. Accordingly, truth and falsity which are defined based on compatibility of the scientific form with the external object, respectively. It is only meaningful about formal science. If scientific form is in accordance with out it will be true otherwise, it would be false. So, Suhrawardi's point (ostensible purpose) of formal science is the acquiring or gaining science. There is another type of science against formal science that needs not to match. This kind of science which is called illuminative shows a clear relationship and supplement between the universe and known which Suhrawardi takes it as "illuminative addition". In this kind of science, soul of the universe surrounds known and there is no need to acquire or gain the scientific form. It is obvious that in this world there is no possibility of error, because error or false is the incompatibility of scientific form and external object, while scientific form cannot do as an intermediate in the Illumination sciences in any way.

So, illuminating science is completely based on knowledge of presence (physical science).

Classification of acquiring or gaining knowledge into notion and authentication:

In logic, science is divided into notion and authentication. If scientific form shows a relationship of something than to another thing it is authentication otherwise, it is called notion. Suhrawardi notes that this division is in relation with acquiring (gaining) or formal science but then notion or authentication cannot be included in physical science (knowledge of presence), because both notion and authentication are kinds of scientific form, while in the physical science (knowledge of presence) there is no scientific form and the known is indirectly and immediately perceived. Therefore, the division of notion and authentication is not an absolute science but it is only an acquiring or gaining science. Notion and authentication is senseless about science which is a kind of physical science (knowledge of presence), because in this science, the existing of illuminated universe will suffice to known (ascertain) and there is no need for scientific form to be an intermediate. Also science of God is not of notion or

authentication kind, but of surrounded existential and illuminated presence.

### Surface science and inner science:

There is another division of science that can be seen in Persian treatise of Safire-e-Simorgh. Suhrawardi in this treatise separates the surface and inner science from each other. Common science and technology amongst the people are of surface science. Suhrawardi also considers most of the provisions of worship and transactions such as divorce, Ataq and bill in the group of surface science which are against the inner science and it is a science that stems from development scenarios Qiyomat and Kbrya and Roboobiyyat and those who know this science can aware of the orders of universe and Kingdom of God and Hidden secrets of heaven and earth. If it is noted in prophet's Hadith (words) that "God never chooses an ignorant representative, then prophet himself asks for science and knowledge from God and He seeks science and knowledge, never assume that its purpose is surface science, but also inner knowledge is included. According to Suhrawardi's descriptions, surface and inner knowledge is based on acquiring and physical knowledge, respectively.

We mean formal science by surface knowledge which Suhrawardi considers them in the group of mediated or acquired knowledge, but the inner knowledge is a kind of immediate or physical awareness and therefore it is associated with illuminated knowledge or talented wisdom. So, Suhrawardi's theory of knowledge must be expressed in three parts:

1. Sense perception (feeling)
2. Mental science
3. Physical science

### Conclusions:

What is extracted in this article is that a science on which Suhrawardi studies is a wisdom based on discussions and witnesses. His intended wisdom is not discussable and theoretic wisdom. Sheykh Shahb Al-Din Suhrawardi believes that wisdom is an instrument or tour of hunting. In addition to his emphasis on his own witnesses Sheykh believes that there are two ways of realities in philosophy;

The intuitive and rational ways and these two are not incompatible. In fact, we should know that in epistemology system of Sheykh Ishraq also wisdom is necessary, like a progression wing of intellect, to transcendental journey of man, and Sheykh never orders to his followers deny or scorn the reason and always finds the rational reasoning topic as an instrument of knowing the realities and considers it necessary but not enough.

### References:

1. Rhamimian, Hussein, theoretical foundations of spirituality, 1388, Tehran, SAMT publishing.
2. Shirazi, Qutbuddin, Hikmah Al-Isharaq description, 1405 qamari, Tehran, Bidar publishing.
3. Shirazi, Qutbuddin, the description of the Hikmah Al-Isharaq Mosannafat-e Mir set, 1405, Tehran, Bidar publishing.
4. Fo'aad, Mohamed Abdalbaki, Almefres Aljum distract, 1388, Tehran, publication Zhkan.
5. Malekshahi, Hassan, description of Isharat wa Tanbihat (remarks and admonitions), 1385, Tehran, sorush publishing.
6. Ashtiani, Sayyed Jalal al-Din, description of the introduction to fosos-e- Qaesarea, 1380, Qom, Bostan-e-Kitab publishing.
7. Ebrahimi Dinani, Gholam-Hossein, the arrays of the thought and intuition in the philosophy of Suhrawardi, 1388, Tehran, Hikmat publication.
8. Karbon, Henri, Mosannafat-e Sheykh Ishraq, 1396, Q.Tehran, community of Hikmat publishing.
9. Movahhed, Samad, originates from Ishraq, 1374, Faravan publishing.

10/03/2012



**False belief about etiology of cancer**

Ali M. Al-Amri, MD

Department of Internal Medicine/Oncology, College of Medicine, University of Dammam, King Fahd Hospital of the University, Al-Khobar, Eastern Province, Kingdom of Saudi Arabia.

Correspondence to: Dr. Ali M. Al-Amri, MD, Department of Internal Medicine and Oncology, King Fahd Hospital of the University, Al-Khobar 31952, PO Box 40182, Saudi Arabia. Telephone 9663896741, E-mail: [aliamri49@hotmail.com](mailto:aliamri49@hotmail.com).

**Abstract:** To many, the etiology of cancer remains one of the mysterious myths among many of patients suffering of cancer in spite of the plenty of information available nowadays. Even though, many cancer patients can be treated and their diseases can be cured, they are still blaming others for the etiology of their suffering, specially their friends, family members or neighbors. In our area, many cancer patients continue to believe in false idea (al-ain) as a cause of their cancer. This believes can lead to cultivation of fears and affect the relation of cancer patients to their close relatives, friends and even can interfere with cancer management. It is important, therefore, to study this myth and explore if it has any role in relation to the etiology of cancer disease.

[Ali M. Al-Amri. **False belief about etiology of cancer.** *Life Sci J* 2012;9(3):2230-2232] (ISSN:1097-8135). <http://www.lifesciencesite.com>. 398

**Keywords:** al-ain, cancer, cause, exponential, patients

**Introduction**

The relationship between physical and psychological health is obscure. Currently, there is no evidence that stress, death of relatives, divorce and others adverse life events are a direct cause of cancer.<sup>1-6</sup>

There is no yet clinical evidence that alain can cause or contribute to cancer and to my knowledge this is the first study about al-ain as a cause of cancer. When patients are diagnosed with cancer, they are very often desperate to find any reason or explanation for their disease. Some of the patients believe alain is the causes of cancer. The patients said this is an effect of visual array which initiate cancer and lead to imminent death.

In this study, we evaluate if there is correlation of al-ain as described by the patients, with their malignant disease.

**Patients and methods:**

This study was carried out at King Fahd Hospital of the University at al-khobar. It is an open interview and questions with patients suffering of cancer. We interviewed only patients who mentioned al-ain as the cause of their cancer and patients who did not mention al-ain were not included in this study. This interview was accomplished in 2 days. In the first day, data about al-ain were collected and in the second day close review of the symptoms of the patients were carried out. The description of al-ain and information related to al-ain are reflective of the patients view. Devil person is the person who is able to use al-ain to cause immediate harm. Al-ain is the adverse outcome of talk or touch of devil person by mentioning the

patient's good health, appetite or look. The talk or the touch of the devil person should be accompanied with surprise without faith of god.

**Results:**

A total of 42 patients were included in this study as shown in table1. These patients had different type of cancer. 22 (52.38%) patients were male and 20 (47.62%) were female. In all patients, prior to symptoms review, 100%, the symptoms of cancer were coincidental to al-ain. Ninety-five percent had at least tumor  $\geq 3$ cm or metastatic disease at the time of al-ain. All of them they haired talk or touch with talk from the devil person mentioning their good health or nice look and immediately started to complain of symptoms as shown in table1. Twenty-seven (64.28%) of the devil persons were relative of the patients. These devil persons had history of breaking cars, glasses and causing harm to others but none of these events were witnessed by the patients themselves as shown in table2. Table3 show that 40 (95.24%) of the patients had many symptoms prior to al-ain time of at least 2 weeks. Only 2 (4.76%) had coincidental symptoms.

**Discussion**

Several cancer patients believed that cancer was caused by many factors such as family history, lifestyle and a trigger such as a virus or stress. In our area, cancer patients believed al-ain is a cuase in adition to what mentioned above.

Neoplasm arises from transformed cells by multi-step carcinogenesis. This process of pre-clinical satge include: initiation, promotion and conversion to malignant cells. The stage from preneoplasia to the

stage of conversion to malignant cells extend from months to years.<sup>7</sup> This length of time prior to suffering of cancer symptoms is the first important factor against al-ain as a cause of cancer in this study.

Exponential growth of converted malignant cells is cellular division with a constant dividing time. One cell divides into two and then four, etc., with each doubling taking the same time. This growth is easily recognizable when graphed. It is a straight line on a semi-log scale.<sup>8,9</sup>

The number of cells is described by the equation  $2^n$  where n is the number of doublings that have taken place. Tissue density is approximately a billion cells per cubic centimeter (cc). A billion is approximately  $2^{30}$ . Ignoring the normal cells, a 1 cc tumor started as a single cancer cell that has divided 30 times to cause symptoms. Data show the time for a breast cancer to double in volume is 25 days to at least 1000 days with a typical value of about 100 days. Combining this information, we can estimate the usual preclinical time of breast cancer as 30 doublings at 100 day or a total of 8 years.<sup>10</sup> Table 1 indicate that all patients said that al-ain was affected them on the day they start to complain of symptoms. That mean the malignant cells have reached large size with long time prior to cause these

symptoms. This paradox of exponential growth time of beginning of cancer and the timing of al-ain is the second important factor against al-ain as a cause of cancer.

The third important reason against al-ain as a cause of cancer that the old events of the devil persons were not witnessed or watched by the patients. The patients said they hair about these events only even though 40% of these devil persons were close relatives.

The fourth important factor against al-ain as a cause of cancer is the review of the symptoms of the patients. Table 3, shows that 95% of those patients actually had symptoms prior to the al-ain events time and only about 5%, the tow events were coincidental. All of the patients said that al-ain and the disease should be coincidental and occurs on the same time. However, close review of their symptoms show that it is not the case, rolling out what they belief (al-ain) is the cause of their cancer.

In summary, the pre-clinical stage or the multi-step carcinogenesis, the exponential growth of the transformed malignant cells, the un-witnessed previous events and the presence of symptoms prior to al-ain indicated that al-ain is a false belief as a cause of cancer in this study.

Table 1. Demographic of cancer patients

	Gender	Diagnosis	Time of symptoms	Time of ain	Average Size of mass	Description of how devil person affected them
6	M	Lymphoma	2 weeks	2 weeks	3x4cm	Patients heard verbal talk from someone and immediately start to complain of symptoms
2	M	AML	4 weeks	4 weeks	-	
20	F	Breast ca	4weeks	4weeks	3x2 cm with metastasis	
5	M	CML	1 weeks	1 weeks	Met	
2	M	Pancreatic	3 weeks	3 weeks	2x3 with liver met.	
7	M	Prostates ca	4 weeks	4 weeks	Hematuria	

Table 2: patient's description of the devil persons

patients	Devil person gender	Relations with patients	Type of old events done by devil person	Witnessed events
22	Male	12 with close relation	Break glass,	None
20	Female	15 with close relation	Break watch, Break cars and tires	None

Table 3: close review of the patients symptoms

Patients	Start of symptoms	Symptoms at the Time of ain
14	6 weeks -12 weeks prior to alain time: fatigue, loss of weight, feeling of not the right person, anorexia	Pain
26	2 weeks to 4 weeks prior to al-ain time: sleep disturbance, fever, anorexia, weight loss, stress and anxiety and hematuria	Pain or fever
2	pain at the same time and were normal prior to alain time	Pain

**References**

1. Priestman TJ, Priestman SG, Bradshaw C. Stress and breast cancer. *Br J Cancer*. 1985;51:493–498.
2. Kvikstad A, Vatten LJ, Tretli S, Kvinnsland S. Death of a husband or marital divorce related to risk of breast cancer in middle-aged women: a nested case-control study among Norwegian women born 1935–1954. *Eur J Cancer*. 1994;4:473–477.
3. Kvikstad A, Vatten LJ. Risk and prognosis of cancer in middle-aged women who experienced the death of a child. *Int J Cancer*. 1996;67:165–169.
4. Johansen C, Olsen JH. Psychological stress, cancer incidence and mortality from non-malignant diseases. *Br J Cancer*. 1997;75:144–148.
5. Chen CC, David AS, Nunnerly H, et al. Adverse life events and breast cancer: case-control study. *BMJ*. 1995;311:1527–1530.
6. Roberts FD, Newcomb PA, Trentham-Dietz A, Storer BE. Self-reported stress and risk of breast cancer. *Cancer*. 1996;77:1089–1093.
7. Charles M Haskell. Introduction. In: *Cancer Treatment* 5th ed. W.B Saunders company. 2-8.
8. Courtney JG, Longnecker MP, Theorell T, de Verdier G. Stressful life events and the risk of colorectal cancer. *Epidemiology*. 1993;4:407–414.
9. Brown BW, Atkinson EN, Bartoszyński R, Thompson JR, Montague ED. Estimation of human tumour growth rate from distribution of tumour size at detection. *J Natl Cancer Inst* 1984, 72:31-38.
10. Norton L. A Gompertzian model of human breast cancer growth. *Cancer Res*. 1988, 48:7067-7071.

9/17/2012

## The Evaluation of Right Atrial Temporary Pacing for Preventing Postoperative Atrial Fibrillation Following Coronary Artery Bypass Grafting Surgery: prospective observational study

Abbasi Tashnizi Mohammad<sup>1</sup>, Moeinipour Ali Asghar<sup>2</sup>, Mirzai Asadollah<sup>3</sup>, Asadollah Jalal<sup>4</sup>, Sadraee Javad<sup>5</sup>, Sepehri Shamloo Alireza<sup>6</sup>, Zirak Nahid<sup>7</sup>, Khameneh Bagheri Ramin<sup>8</sup>, Amouzeschi Ahmad<sup>9</sup>

1. Department of Cardiac Surgery, Imam Reza Hospital, Mashhad University of Medical Sciences, Mashhad, Iran.
2. Department of Cardiac Surgery, Imam Reza Hospital, Mashhad University of Medical Sciences, Mashhad, Iran.
3. Department of Cardiac Surgery, Imam Reza Hospital, Mashhad University of Medical Sciences, Mashhad, Iran.
4. Department of Cardiac Surgery, Imam Reza Hospital, Mashhad University of Medical Sciences, Mashhad, Iran.
5. Department of Cardiac Surgery, Imam Reza Hospital, Mashhad University of Medical Sciences, Mashhad, Iran.
6. Department of Cardiac Surgery, Imam Reza Hospital, Mashhad University of Medical Sciences, Mashhad, Iran.
7. Department of Cardiac Surgery, Imam Reza Hospital, Mashhad University of Medical Sciences, Mashhad, Iran.
8. Department of Cardiac Surgery, Imam Reza Hospital, Mashhad University of Medical Sciences, Mashhad, Iran.
9. Department of Cardiac Surgery, Imam Reza Hospital, Mashhad University of Medical Sciences, Mashhad, Iran.

**Abstract:** Atrial fibrillation (AF) is the most frequent (arrhythmia) complication following coronary artery bypass grafting surgery (CABG). The present study is designed to evaluate the efficacy of temporary atrial pacing in the prevention of AF after off pump coronary artery bypass graft surgery. The patients who had first-time off-pump CABG were enrolled in the study. The exclusion criteria were that the patients had valve dysfunctions. The study group (n = 39) were paced electively and the control group (n = 40) were not paced, and both were monitored for 96 hours postoperative for the occurrence of AF. The end points of the study were occurrence of AF, death during postoperative period, and discharge from hospital. The data analyzed by t-test and chi-squared test for variables. A total of 120 patients enrolled in the study. Forty-one patients were excluded from the study because of intraoperative dysrhythmia, tachycardia or failure of pacing, so the final study subjects consist of 79 patients. AF occurred in 13 of 39 paced group (33.33%) and 13 of 40 non-paced group (32.5%). No statically significant difference in the proportion of patients developing atrial fibrillation was observed between the study and the control group for incidence of AF. Old age (P=0.007), history of myocardial infarction (P=0.001), systolic dysfunction (P=0.003), ejection fraction (P=0.022) and atrial enlargement (P=0.001) were identified as AF predictors. The result of this study shows that prophylactic right atrial pacing had no significant effect on reducing the incidence of AF following off-pump CABG.

[Abbasi Tashnizi Mohammad, Moeinipour Ali Asghar, Mirzai Asadollah, Asadollah Jalal, Sadraee Javad, Sepehri Shamloo Alirez, Zirak Nahid, Khameneh Bagheri Ramin, Amouzeschi Ahmad. **The Evaluation of Right Atrial Temporary Pacing for Preventing Postoperative Atrial Fibrillation Following Coronary Artery Bypass Grafting Surgery: prospective observational study.** *Life Sci J* 2012;9(3):2233-2237] (ISSN:1097-8135). <http://www.lifesciencesite.com>. 399

**Key words:** Atrial fibrillation; Coronary artery bypass grafting; Atrial pacing

### 1. Introduction

Atrial fibrillation (AF) is the most frequent (arrhythmia) complication following coronary artery bypass grafting surgery (CABG) and “The incidence of postoperative atrial fibrillation is approximately 30% after isolated coronary artery bypass grafting (CABG) surgery, 40% after valve replacements or repair, and increases to approximately 50% after combined procedures (1).” It is typically seen between the second

and fourth postoperative days and the highest incidence is in the second day after surgery (2). Initially it was thought that AF is harmless, but is now recognized as a dangerous postoperative condition (3). Although this complication is well tolerated in patients but Atrial fibrillation may lead to hemodynamic instability especially in those patients who have left ventricular diastolic dysfunction function (4).

Postoperative atrial fibrillation (PAF) is associated with prolonged hospital stay, and reduced in-hospital and long-term survival, an increased early stroke risk and sometimes causes serious injuries in patients undergoing coronary artery bypass surgery (5).

Due to the disadvantages and the limited efficacy of pharmacological prophylaxis, there has been a great attempt in the development of nonpharmacologic techniques to prevent postoperative AF. With limited use of beta blockers and amiodarone as prevention of postoperative atrial fibrillation (6, 7), new methods have been proposed to avoid this complication furthermore they avoid the toxicity of antiarrhythmic drugs. Among non-pharmacological methods to prevent postoperative atrial fibrillation, right atrial pacing therapies have decreased the incidence of AF from 42% to 13% on average and in other study it has reported 31.1% to 5.2% (8). Some studies have shown that patients who get atrial or dual chamber pacemakers have fewer episodes of AF than those get ventricular pacemakers, but its impact is not definite yet (9, 10, 11).

The present study is designed to evaluate the efficacy of right atrial temporary pacing in the prevention of atrial fibrillation after off-pump coronary artery bypass surgery and to compare the incidence of postoperative AF between patients with and without right atrial temporary pacemakers.

## 2. Materials and Methods

Over a period of eight months (February 2011 –September 2011) a total of 120 patients who had first-time off-pump CABG were enrolled in this prospective observational study. All these patients were treated in the open-heart surgery ward at Imam Reza teaching hospital, the main referral hospital in north eastern Iran.

The trial was performed in accordance with the declaration of Helsinki and approved by ethic committee at Mashhad University of Medical Sciences. Written informed consents were obtained before entering into the study.

The inclusion criterion was that all the patients who had first-time off-pump CABG and the exclusion criteria was that patients had history of supraventricular (including atrial flutter or AF) or ventricular tachyarrhythmia, intraoperative AF, use of cardiopulmonary bypass for CABG, valve dysfunctions, and preoperative heart failure.

Forty-one patients were excluded from the study because of intraoperative dysrhythmia. Patients randomly divided into 2 groups. The study group (n = 39) consisted of patients who had been operated on by one surgeon and paced electively in the postoperative period. During the same period, patients with off-pump CABG operations carried out by the same surgeon and were not paced served as the control group. (n = 40). In the study

group, before sternal closure, two temporary epicardial pacing wires (model 2500 Medtronic Inc) were fitted to the epicardium of the right atrium, one near the site of sinus node and the other one, on the lateral wall of the right atrium; then, the right atrial (RA) pacing (AAI mode) was set at rate of 90/min-120/min and the sensitivity of 0.25mv after transferring the patient to intensive care unit. Pacing threshold and sensitivity were checked and reset as needed during each of the following 18 hours and the pacing was continued for 96 hours if the patient had a normal sinus rhythm. So both groups underwent continuous pacing and electrocardiographic monitoring for four days after surgery, and beta-blockers were administered on the first day after the CABG. The end points of the study were the occurrence of AF, the passing 96 hours after the surgery, the death during postoperative period, and discharge from hospital. In the control group, the operations were the same with the study group, but no atrial pacing wires were fitted in these patients. Considering the influence of electrolyte disturbances and hypoxia in incidence of atrial fibrillation, serum potassium and calcium, and oxygen saturation of arterial blood was daily measured in both groups.

Left ventricular diastolic and systolic dysfunctions, left atrial enlargement and a history of myocardial infarction were also recorded to consider in the results for incidence of atrial fibrillation.

The data was analyzed with SPSS version 13 (SPSS Inc., Chicago, IL, USA). Summary statistics were expressed by mean, frequency or numbers and percentages of the patients. The two groups were compared by standard t-test and Chi-squared test for variables. If some of the confounding variables in both groups were not homogeneous, we used logistic regression method for these variables. For all tests, a p-value value of <0.05 was considered significant.

## 3. Results

A total of 120 patients enrolled in the study. Forty-one patients were excluded from the study because of intraoperative dysrhythmia, so the final study subjects consist of 79 patients. 39 patients entered to the study group (right atrial pacing) and 40 patients were in the control group (no atrial pacing). According to preoperative characteristics of patients, no statically significant difference was observed between the study and the control group. There were no complications due to the placement or removal of the atrial electrodes and no patient died during the study period.

There was no significant difference in the proportion of patients developing atrial fibrillation in two groups. (Study group vs. control group adjusted OR=1.03, 95%CI; p=0.82) Incidence of AF was reported in 26 patients (Table 2). Average time to onset

of atrial fibrillation was non-significantly shorter in the control group than the study group. (Study group=41.0±10 h, control group 35.3±13 h; p=0.488)

Then we investigate the characteristics of patients with and without incidence of AF. (Table 3)

#### 4. Discussion

The purpose of this study was to assess the efficacy of right atrial temporary pacing for the prevention of postoperative atrial fibrillation (AF). We found that there was no significant difference between the proportion of patients with right atrial (RA) pacemakers developing atrial fibrillation and the proportion of patients without right atrial pacemakers. In fact, our study shows that temporary right atrial pacing after CABG surgery does not reduce the occurrence of postoperative AF. However, other studies show the effectiveness of pacemakers in reducing the incidence of postoperative AF (12, 13).

Therefore, since 1960, epicardial pacing in cardiac surgery has been common as a method of counteraction or prevention of A few hours before, after, and while performing the surgery arrhythmias and this procedure has been used to maintain cardiac output and performance (14).

Based on the "prevention is better than the cure strategy," several methods for preventing postoperative AF have been proposed. These methods include the use of beta-blockers in the pre, intra, and postoperative periods alone or in combination (15, 16), statins administration before and after surgery, off-pump CABG operation, upper thoracic epidural anesthesia and rapid extubation after surgery (17, 18, 19).

Several clinical factors have been considered as factors that increase the incidence of postoperative AF, Age, hypertension, a history of AF, male gender, obesity, chronic obstructive pulmonary disease, prolonged cardiopulmonary bypass, left atrial with increased size, and left ventricular with decreased ejection fraction (20-26). In this study, we observed that underlying factors such as gender, right atrial pacemakers, hypertension, diastolic dysfunction, number of grafts, serum calcium and potassium level and oxygen saturation were not associated with the incidence of postoperative AF, However, old age (P=0.007), history of myocardial infarction (P=0.001), systolic dysfunction (P=0.003), ejection fraction (P=0.022) and atrial enlargement (P=0.001) were identified as the AF risk factors.

Banach et al. (27) selected twelve hundred patients to evaluate the risks factors of atrial fibrillation (AF) following coronary artery bypass grafting (CABG). Statistical analysis identified 5 risk factors of AF: advanced age, history of supraventricular arrhythmias, preoperative heart failure, operation with standard CABG technique and repeated revascularization and

this trial also indicated that administration of beta-blockers and the OPCAB (off-pump CABG) operating technique were identified as protective factors. All these risk factors except advanced age were considered as the exclusion criteria of our study.

The trials that investigated the use of RA pacing alone for controlling of AF after cardiac surgery have yielded mixed results.

Fan et al. (28) studied 137 patients, randomizing them to 4 groups, biatrial, right atrial, left atrial and a control group. They found that the incidence of AF in the RA, LA and control groups were 36%, 33% and 42% respectively, but the incidence in the biatrial pacing group was 12.5%. Thus they concluded that biatrial pacing was a better strategy in the controlling of postoperative AF. Incidence of AF in this study RA group (36%) was almost similar to our RA group (33.3%) and perhaps if we did BA on our patients, we might report the similar incidence of AF among them as well.

Chung et al. (29) studied 100 patients with and without post-CABG atrial pacing. The results demonstrated atrial fibrillation occurred by day 4 in 13 of 51 (25.5%) paced patients and in 14 of 49 (28.6%) Control patients (p = 0.9). Gerstenfeld et al. (30) conducted a study on 61 post-CABG patients who were randomly divided into three groups: control (NAP), right atrial pacing (RAP) and biatrial pacing (BAP). There was no significant difference in the proportion of patients developing AF in that trial three groups (NAP 5 33%; RAP 5 29%; BAP 5 37%; p> 0.7). But he suggested for further studies on the effect of combined beta-blocker drugs and pacing.

Avila Neto et al. (31) surveyed the effect of temporary right atrial pacing in prevention of AF after CABG on 160 patients. They find a reduced the incidence of atrial fibrillation after the surgery. The incidence of AF was 13.1% (12.5% in non-pacing and 0.6% in right atrial pacing group). They also indicated that older age and non-atrial pacing were the risk factors of post-CABG atrial fibrillation but in our study just the older age was similar as the risk factor. This conclusion about the effectiveness of pacemakers' prevention therapy is also confirmed by Singhal et al. (32) and Greenberg et al. (33).

Archbold and Schilling reviewed the literature regarding the efficacy of epicardial atrial pacing to prevent post-CABG AF during 13 studies. Overall, they conclude that biatrial epicardial pacing appears to be effective prophylaxis against post-CABG AF (34).

Any complication related to pacing wire removal didn't observed. Pacing was safe and well tolerated in patients, and did not increase hospitalization period.

In another study, Chavan et al. studied (35) Bachmann Bundle pacing as an alternative approach in prevention of AF after CABG. Results showed that

incidence of AF were 0% in Bachmann Bundle pacing group whereas it was 16.6% in No pacing and 12.5% in RA pacing groups.

Considering the results of this study and of other studies, it seems that the use of right atrial pacemakers to control postoperative AF is debated. However, biatrial pacing seems to be more favorable in reducing the incidence of post-CABG AF (35).

The number of patients in this study is small. Therefore, for a more definite conclusion, it would be better to perform this study in a larger group. In this study, only the right atrium was paced, and it might be better if we studied on biatrial (BA) pacing as well.

Although many trials regarding the evaluation of pacing for the prevention of postoperative AF following CABG have been conducted, we did not find any trial investigating the relative benefits or risks of surgery to upgrade to a dual chamber pacemaker. Considering the results of the trials, we now believe that the more favorable efficacy of biatrial pacing as an AF prevention strategy is obvious, but we are not sure if the complications of this procedure are less in comparison with right atrial pacing. Therefore, the next step is to assess and compare the post-operative complications of BA and RA pacing following CABG.

**Table 1.** Characteristics of patients before off-pump CABG.

	Study group (n=39)	Control group (n=40)	p-value
Age (mean±SD, year)	63.7±7	61.6±9	NS
Gender (male/female)	26/13	25/15	NS
Hypertension (%)	74.4%	70%	NS
Recent MI* <sup>1</sup> (%)	35.9%	30%	NS
Systolic dysfunction* <sup>2</sup> (%)	51.3%	40%	NS
Diastolic dysfunction (%) <sup>3</sup>	92.3%	82.5%	NS
Left atrial enlargement (%)	6 (15.4%)	3 (7.5%)	NS
Left ventricular ejection fraction (mean±SD)	45.0±9.07	45.7±9.47	NS

\*1. MI: Myocardial infarction

\*2. Systolic dysfunction: Refers to impaired left ventricular contraction.

\*3. Diastolic dysfunction: Refers to decline in performance of left ventricles of the heart during the time phase of diastole.

**Table 2.** The incidence of atrial fibrillation, according to groups.

Group (n)	Postoperative AF*, n (%)
Total patients (79)	26 (32.9%)
Study group-with right atrial pacing (39)	13 (33.3%)
Control group-without atrial pacing (40)	13 (32.5%)

\* AF= Atrial fibrillation is confirmed with an electrocardiogram (ECG or EKG) which demonstrates the absence of P waves together with an irregular ventricular rate.

**Table 3.** Comparison of with and without AF patients' characteristics

Groups (n)	Patients with AF (26)	Patients without AF (53)	p-value
Age (mean±SD, year)	67.0±9	60.6±9	P=0.007
Gender (male/female)	15/11	36/17	NS
Hypertension (%)	86.0%	66.0%	NS
Recent MI** (%)	61.5%	18.9%	P=0.001
Oxygen saturation (%)	95.1±2.4	94.5±2.6	NS
serum calcium level (mEq/L)	4.4±0.3	4.5±0.3	NS
serum potassium level (mEq/L)	4.0±0.5	3.9±0.4	NS
Systolic dysfunction (%)	69.2%	34.0%	P=0.003
Diastolic dysfunction (%)	92.3%	84.9%	NS
Left atrial enlargement (%)	23.1%	5.7%	P=0.022
The mean number of grafts	3.53	3.58	NS
Left ventricular ejection fraction (mean±SD)	39.8±7.3	48.2±8.8	P=0.001

\*AF: atrial fibrillation

\*\*MI: myocardial infarction

### Acknowledgements

This study has been financially supported by Medical Faculty of Mashhad University of Medical Sciences.

### References

- Echahidi N, Pibarot P, O'Hara G, Mathieu P. Mechanisms, prevention, and treatment of atrial fibrillation after cardiac surgery. *J Am Coll Cardiol.* 2008; 51 (8): 793–801.
- Selvaraj R. Prevention of postoperative atrial fibrillation - a stitch in time. *Indian Pacing Electrophysiol J.* 2011 Feb 7;10(12):526-8.
- Hogue CW, Hyder ML. Atrial fibrillation after cardiac operation: risks, mechanisms, and treatment. *Ann Thorac Surg.* 2000; 69:300–6.
- Kowey PR, Stebbins D, Igidbashian L, Goldman SM, Sutter FP, Rials SJ, et al. Clinical outcome of patients who develop PAF after CABG surgery. *Pacing Clin Electrophysiol.* 2001; 24(2):191-3.
- Crystal E, Connolly SJ, Sleik K, Ginger TJ, Yusuf S. Interventions on prevention of postoperative atrial fibrillation in patients undergoing heart surgery: a meta-analysis. *Circulation.* 2002;106(1):75-80.
- Leitch JW, Thomson D, Baird DK, Harris PJ. The importance of age as a predictor of atrial fibrillation and flutter after coronary

- artery bypass grafting. *J Thorac Cardiovasc Surg.* 1990;100(3):338-42
7. Coleman CI, Perkinson KA, Gillespie EL, Kluger J, Gallagher R, Horowitz S, et al. Impact of prophylactic postoperative beta-blockade on post-cardiothoracic surgery length of stay and atrial fibrillation. *Ann Pharmacother.* 2004;38(12):2012-6.
  8. Singhal P, Kejriwal N. Right atrial pacing for prevention of postoperative atrial fibrillation following coronary artery bypass grafting: a prospective observational trial. *Heart Lung Circ.* 2010 Jul;19(7):395-9.
  9. Edward P Gerstenfeld, Michael R.S Hill, Steven N French, Rahul Mehra, Karen Rofino, Thomas J Vander Salm, Robert S Mittleman, Evaluation of right atrial and biatrial temporary pacing for the prevention of atrial fibrillation after coronary artery bypass surgery, *Journal of the American College of Cardiology*, Volume 33, Issue 7, June 1999, Pages 1981-1988, ISSN 0735-1097, 10.1016/S0735-1097(99)00115-1.
  10. E.B. Sgarbosa, S.L. Pinski, J.D. Maloney et al. Chronic atrial fibrillation and stroke in paced patients with sick sinus syndrome: relevance of clinical characteristics and pacing modalities. *Circulation*, 88 (1993), pp. 1045–1053
  11. H.R. Andersen, L. Theusen, J.P. Bagger, T. Vesterlund, P.B. Thomsen. Prospective randomised trial of atrial versus ventricular pacing in sick-sinus syndrome. *Lancet*, 344 (1994), pp. 1523–1528
  12. Burgess DC, Kilborn MJ, Keech AC. Interventions for prevention of post-operative atrial fibrillation and its complications after cardiac surgery: a meta-analysis. *Eur Heart J.* 2006;27:2846–57.
  13. Crystal E, Garfinkle MS, Connolly SS, Ginger TT, Sleik K, Yusuf SS. Interventions for preventing post-operative atrial fibrillation in patients undergoing heart surgery. *Cochrane Database Syst Rev.* 2004;4:CD003611.
  14. Wakamatsu H, Takase S [Effect of intra-operative low-dose infusion of landiolol hydrochloride on post-operative atrial fibrillation after off-pump coronary artery bypass grafting]. *Kyobu Geka* 2010 Aug;63(9):764-8
  15. Tanaka K. [Effects of landiolol on hemodynamic improvement and prevention of atrial fibrillation in the perioperative period of off-pump coronary artery bypass grafting] *Kyobu Geka.* 2010 Mar;63(3):175-9
  16. Ji Q, Mei Y, Wang X, Sun Y. Effect of preoperative atorvastatin therapy on atrial fibrillation following off-pump coronary artery bypass grafting. *Circ J.* 2009 Dec;73(12):2244-9
  17. Anselmi A, Possati G, Guadino M. Postoperative inflammatory reaction and atrial fibrillation: simple correlation or causation?. *Ann Thorac Surg* 2009 Jul;88(1):326-33
  18. Bakhtiari F, Therapidis P, Dzembali O, Ak K, Heining D, Kessler P, Kleine P, Moritz A, Aybek T, Dogan S. Impact of high thoracic epidural anesthesia on incidence of perioperative atrial fibrillation in off pump coronary bypass grafting: a prospective randomized study. *J Thorac Cardiovasc Surg* 2007 Aug;134(2):460-4
  19. Hemmerling TM, Minardi C, Zaouter C, Noiseux N, Perieto I. Sevoflurane causes less arrhythmias than desflurane after off-pump coronary artery bypass grafting: a pilot study. *Ann Card Anaesth.* 2010 May-Aug;13(2):116-22
  20. Zaman AG, Archbold RA, Helft G, Paul EA, Curzen NP, Mills PG. Atrial fibrillation after coronary artery bypass grafting: a model for preoperative risk stratification. *Circulation* 2000;101:1403–8.
  21. Maisel WH, Rowan J D, Stevenson WG. Atrial fibrillation after cardiac surgery. *Ann Intern Med* 2001;135:1061–73.
  22. Mathew JP, Parks R, Savino JS, Friedman AS, Koch C, Mangano DT, Browner WS. Atrial fibrillation following coronary artery bypass graft surgery: predictors, outcomes, and resource utilization. MultiCenter Study of Perioperative Ischemia Research Group. *JAMA* 1996;276:300–6.
  23. Aranki SF, Shaw D P, Adams DH, Rizzo RJ, Couper GS, VanderVliet M, Collins Jr JJ, Cohn LH, Burstin HR. Predictors of atrial fibrillation after coronary artery surgery: current trends and impact on hospital resources. *Circulation* 1996;94:390–7
  24. Mathew JP, Parks R, Savino JS, Friedman AS, Koch C, Mangano DT, Browner WS. Atrial fibrillation following coronary artery bypass graft surgery: predictors, outcomes, and resource utilization. MultiCenter Study of Perioperative Ischemia Research Group. *JAMA* 1996;276:300–6.
  25. Zacharias A, Schwann TA, Riordan CJ, Durham SJ, Shah AS, Habib RH. Obesity and risk of new-onset atrial fibrillation after cardiac surgery. *Circulation* 2005;112:3247–55.
  26. Zacharias A, Schwann TA, Riordan CJ, Durham SJ, Shah AS, Habib RH. Obesity and risk of new-onset atrial fibrillation after cardiac surgery. *Circulation* 2005;112:3247–55.
  27. Banach M, Rvz J, Drozd JA, Okonshki P, Misztal M, Barylski M, Irzmanski R, Zaslonka J. Risk factors of atrial fibrillation following coronary artery bypass grafting. *A preliminary report.* *Circ J* 2006 Apr;70(4):438-441
  28. Fan K., Lee KL., Chiu CS., Lee JW., He GW., Cheung D., Sun MP., Lau CP. Effects of biatrial pacing in prevention of postoperative atrial fibrillation after coronary artery bypass surgery. *Circulation* 2000;102:755-60
  29. Chung MK, Augostini RS, Asher CR, Pool DP, Grady TA, Zikri M, Buehner SM, Weinstock M, McCarthy PM. Ineffectiveness and potential proarrhythmia of atrial pacing for atrial fibrillation prevention after coronary artery bypass grafting. *Annals of Thoracic Surgery* 2000; 69(4):1057–63.
  30. Gerstenfeld EP, Hill MR, French SN, Mehra R, Rofino K, Vander Salm TJ, Mittleman RS. Evaluation of right atrial and biatrial temporary pacing for the prevention of atrial fibrillation after coronary artery bypass surgery. *Journal of the American College of Cardiology* 1999;33:1981-8.
  31. Avila Neto V, Costa R, Silva KR, Martins ALM, Moreira LF, Pinho, Santos LB, et al. Effect of temporary right atrial pacing in prevention of atrial fibrillation after coronary artery bypass graft surgery. *Rev Bras Cir Cardiovasc.* 2007;22:332–40.
  32. Singhal P.M, Kejriwal F. Right Atrial Pacing for Prevention of Postoperative Atrial Fibrillation Following Coronary Artery Bypass Grafting: A Prospective Observational Trial. *Lung Circ j* 2010;19(2):395-399
  33. Greenberg MD, Katz NM, Luliano S, Te mpesta BJ, Solomon AJ. Atrial pacing for the prevention of atrial fibrillation after cardiovascular surgery. *J Am Coll Cardiol* 2000;35:1416–22.
  34. Archbold RA, Schilling RJ. Atrial pacing for the prevention of atrial fibrillation after coronary artery bypass graft surgery: a review of the literature. *Heart.* 2004;90:129–133.
  35. Chandrakant Chavan, Mukund Karmalkar, Rajesh Badani, K Sharada, Usha Rani, Prasad Rao, Ram Subramanyam, and C Narasimhan. Evaluation of Bachmann Bundle Pacing Versus Right Atrial Pacing in Prevention of Atrial Fibrillation After Coronary Artery Bypass Surgery. *Indian Pacing Electrophysiol J.* 2010; 10(12): 529–535.
  36. Vora A. To Pace Or Not To Pace! Prevention Of Atrial Fibrillation After Coronary Artery Bypass Surgery. *Indian Pacing Electrophysiol J.* 2005 Jan-Mar; 5(1): 1–4



## Tiny Circularly Polarized Printed Slot Antenna for UWB Usage

Majid Shokri<sup>1</sup>, Ch. Ghobadi<sup>1</sup> and J.Nourinia<sup>1</sup>, Hamed Shirzad<sup>2</sup>, S.Asiaban<sup>2</sup> and Zh.Amiri<sup>2</sup>

1. Department of Electrical and Electronic Engineering, Urmia University, Urmia, West-Azarbayjan, Iran

2. Department of Electrical and electronic engineering, Urmia Branch, Islamic Azad, University Urmia, West-Azarbayjan, Iran

**Abstract:** This letter offers a wideband circularly polarized square slot antenna (CPSSA) fed by coplanar waveguide (CPW), with a compact size of only 25 mm (length)  $\times$  25mm (width)  $\times$  0.8 mm (height). The proposed antenna provides impedance bandwidth of 2.86–10.95 GHz (117%) with VSWR  $\leq$  2, and its CP bandwidth is larger than 47.5% that covers 5.05-8.20 GHz which is obtained by embedding two inverted-L grounded strips around two opposite corners whereas the impedance bandwidth can be greatly improved through the tuning stubs. The simulated and measured results of the proposed antenna have been discussed to verify its characteristics.

[Majid Shokri, Ch. Ghobadi and J.Nourinia, Hamed Shirzad, S.Asiaban and Zh. Amiri. **Tiny Circularly Polarized Printed Slot Antenna for UWB Usage.** *Life Sci J* 2012;9(3):2238-2241] (ISSN:1097-8135). <http://www.lifesciencesite.com>. 400

**Key Words:** slot antenna, circular polarization

### 1. Introduction

Due to attractive properties of printed slot antennas namely wide impedance BW, low profile, and easy fabrication, with various feeding techniques, they have attracted much attention in circular polarization (CP) applications [1]. Recently, various geometries of broadband CP slot antennas have been reported to overcome the narrow impedance and axial-ratio bandwidths (ARBWs) while, both right-hand CP and the left-hand CP are achieved simultaneously with various techniques as follows: embedding two inverted-L grounded strips around two opposite corners of the slot with vertical tuning stub [1], inserting a lightning-shaped feed line and inverted-L grounded strips [2], embedding a T-shaped grounded metallic strip that is perpendicular to the axial direction of the coplanar waveguide (CPW) feed line [3], utilizing a spiral slot in the ground plane [4], utilizing the embedded arc-shaped grounded metallic strip for circular and linear polarization [5]. In this Letter, a tiny, yet structurally simpler, circularly polarized square slot antenna (CPSSA) for UWB systems with the combination of the technique introduced in [1] and a crescent shaped patch is presented. The measurements indicate that it has an impedance bandwidth (BW) of 2.86–10.95 GHz (3.83:1, 117%), which is three times wider than previous square slot antenna structures [2–3].

### 2. Antenna design

Fig. 1 exhibits the geometry of the proposed single-layer CPW-fed CPSS antenna. As it is shown, the proposed antenna consists of a square ground plane, two equal size inverted-L-shaped strips around two opposite corners, a tuning circle stub embedded in the feeding structure and a crescent main patch clung to the feed line (all units are in mm). The proposed CPS

antenna is printed on a commercially cheap FR4 substrate with a loss tangent of 0.024, permittivity of 4.4 and tiny dimensions of 25 mm (length)  $\times$  25mm (width)  $\times$  0.8 mm (height). To achieve 50 $\Omega$  characteristic impedance, the width and length of the coplanar waveguide (CPW) feed line is 3.1 mm and 11.4 mm, respectively, and the width of the gap between the feed line and the ground plane is 0.3 mm. The size of the inverted-L-shaped strips are; a=5mm and b=4mm and the radius and center point of circles 1, 2 and 3 are reported in table 1.

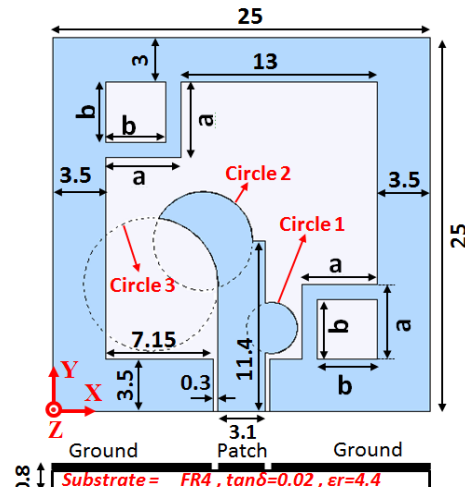


Fig. 1 Geometry of proposed CPW-fed CPSSA (all dimensions in mm)

Table 1: Radius and position of circles 1, 2 and 3

	Circle1	Circle2	Circle3
Radius	R1=1.7mm	R2=3.3mm	R3=4.46mm
Center position	X1=14.5mm Y1=5.6mm Z1=0.8mm	X2=10mm Y2=11.4mm Z2=0.8mm	X3=6.5mm Y3=8.8mm Z3=0.8mm

Other dimensions are shown in Fig1. In the designing of the antenna three steps are accomplished; the first step includes only a single strip and ground plane, the second one consists two inverted-L grounded strips around two opposite corners and a metal circle clung to feed line and the last one encompasses crescent shaped main patch (a part of circle 2). In the Fig.2 a three steps of designing the antenna is seen and VSWR curves of them and measurement VSWR of the proposed antenna are depicted in Fig.2 b.

Mainly two objects have been considered with in the design: one for enhancing the impedance bandwidth and the other for producing and expanding the CP bandwidth which is principally related to inverted-L-shaped strips around two opposite corners. The measured and simulated results of three prototypes of CPSSA, parametric studies on: inverted-L-shaped strips, the size of the radius and center position of stub and patch syndetic to feed line, and finally the measured radiation pattern of the offered antenna will be discussed in next section.

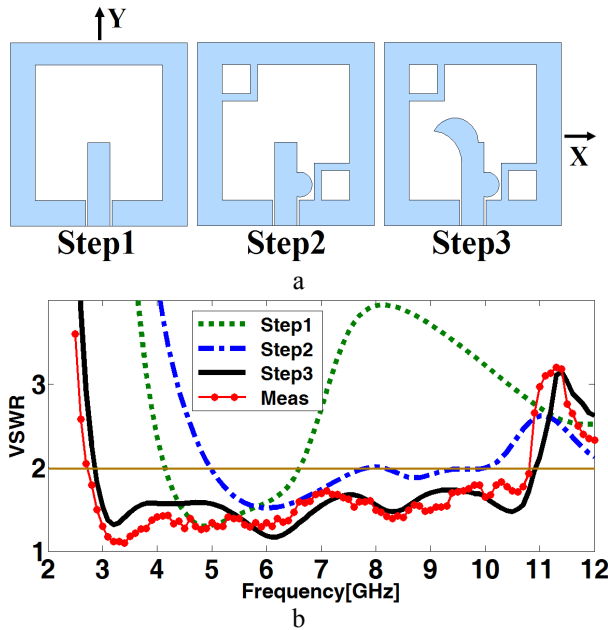


Fig. 2 antenna designing steps, VSWR of antenna steps  
 a) Three steps of designing the antenna  
 b) VSWR curves of the antenna designing steps and measurement vswr results

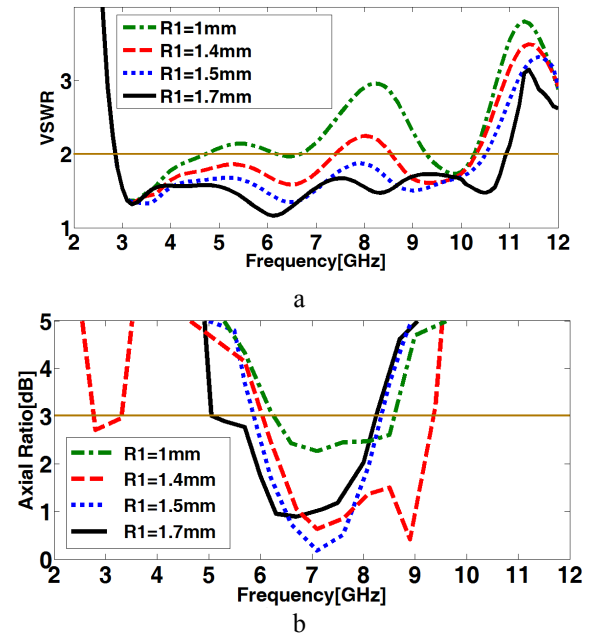


Fig. 3 VSWR and CP axial ratios of various value of R1 (radius of circle1)  
 a) VSWR curves of different values of R1  
 b) CP axial ratios of different values of R1

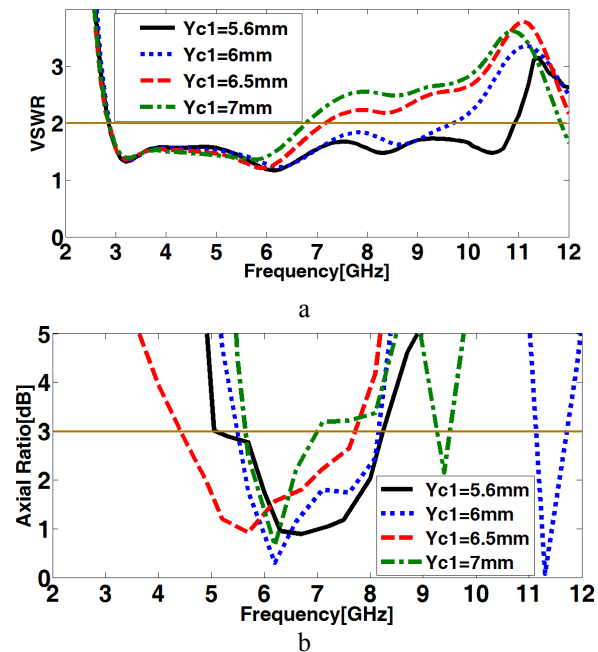


Fig.4 VSWR and CP axial ratios of various value of Yc1 (vertical center position of circle1)  
 a) VSWR curves of different values of Yc1  
 b) CP axial ratios of different values of Yc1

3. RESULTS AND DISCUSSION

In this article two objects have been tracked: one

enhancing the impedance BW and the other producing and expanding the CPBW. As shown in Fig. 2 a and Fig. 2 b for achieving the objects, three steps from CPSSA design techniques have been traversed namely: firstly adopting a square GND plane and a rectangular feed line, secondly embedding a circular stub to the feed line and inverted-L metal strips to ground and at last appending a crescent shape main patch to feed line. From the figures it is clear that adopting the techniques the impedance BW increases step by step and close correspondence between measured and simulated VSWR of the optimized antenna (named as Step3) is a considerable point plotted in the Fig. 2 b and it is also understood from the figure that the measured impedance bandwidth for the antenna has an operating frequency range from 2.86 GHz to 10.95 GHz. The simulated VSWR and CP axial ratio curves for two various CPSSA parameters, R1 and Yc1 (radius of circle1 and its vertical center position respectively) are plotted in Fig.3 and Fig.4. A tuning circular stub (perpendicular to the feed line) which is built by expanding a circular metal with R1 (radius of circle1) =1.7mm, Yc1 (its vertical center position) =5.6mm and Xc1 (its horizontal center position) =14.5mm structural features, is added in the rectangular feeding to broaden the impedance BW. Our parametric simulations indicate that the radius and vertical position of the tuning stub has important affect on improving the impedance BW. From the numerical results in Fig. 3 a, it is gotten that the impedance bandwidth is expanded at the upper frequency as R1 increases from 1mm to 1.7mm, meanwhile broader impedance BW is earned by taking a smaller Yc1 parameter among its values shown in Fig.4 a. On the other hand, as shown in Fig.3 b and Fig.4 b, the optimum values of R1 and Yc1 which simultaneously leads to the widest impedance BW and satisfying CPBW, covering 5GHz-6GHz (IEEE 802.11a), are 1.7mm and 5.6mm respectively. Due to numerical results which were accomplished by using the Ansoft High Frequency Structure Simulator (HFSS), the combination of two inverted-L-shaped strips, made of two arms ( a and b as shown in Fig. 1), to GND has a great effect on both impedance and CP BWs as discussed in Fig 5. It means that increasing a and b (3mm and 2mm to 5mm and 4 mm) will yield not only to additional impedance BW but also a wider CPBW, associated with  $AR \leq 3$  dB, is taken which covers 5150–5350/5725–5825MHz (specified by IEEE 802.11a) bands for wireless standard technologies. Fig.6 indicates the close correspondence between the measured and simulated curves of gain and AR for the proposed antenna with optimized values presented in Fig.1 and in Table1. As plotted in Fig.6, the ARBW of the suggested antenna is from 5050MHz to 8200MHz (47.5%) and its gain is

acceptable. Fig.7 shows the simulated normalized RHCP and LHCP radiation patterns of the offered CPSSA at 5.5GHz and 7.3GHz. We have simulated the time-varying surface current distribution on proposed antenna at 6.8GHz, at the minimum point of AR. The simulation results of surface current distribution for the antenna are shown in Fig.8. It is observed that the surface current distribution in  $180^\circ$  and  $270^\circ$  are equal in magnitude and opposite in phase of  $0^\circ$  and  $90^\circ$ . If the current rotates in the clockwise/counter clockwise (CW/CCW) direction, the antenna can radiate the right/left hand circular polarization (RHCP/LHCP). The proposed CP slot antenna is able to generate an RHCP in the +z direction, whereas an LHCP is produced in the -z direction. The suggested antenna with optimal structure, as shown in Fig. 9, was fabricated and tested in the Antenna Measurement Laboratory at Iran Telecommunication Research Center (ITRC).

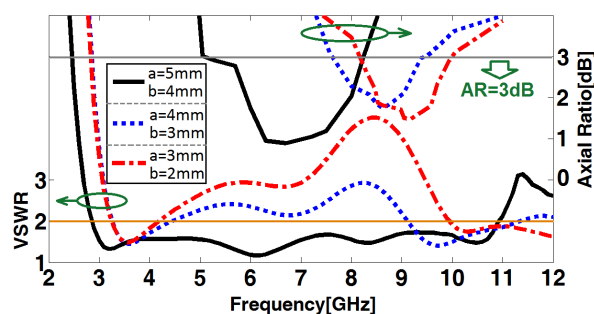


Fig.5 VSWR and CP axial ratios of various values of a and b (arms of the inverted-L-strips)

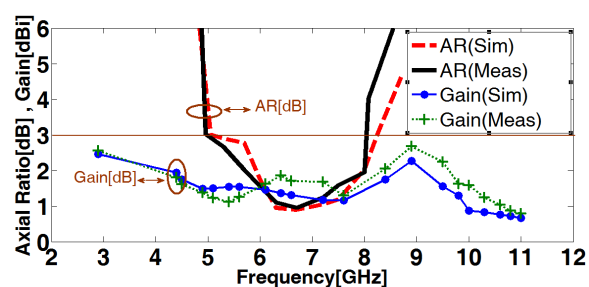


Fig. 6 Measured and simulated CP axial ratios and gain of the proposed antenna

#### 4. Discussion

This paper presents circularly polarized square slot antenna (CPSSA) fed by coplanar waveguide (CPW) with a crescent shaped patch. All of the important parameters that are determinant in antenna characteristics were depicted one by one while keeping the others fixed. At last the antenna's features namely: current distributions, gain level, radiation patterns and agreement between numerical and experimental results acknowledge that this radiator is a good candidate for

5150–5350/5725–5825MHz (specified by IEEE 802.11a) bands for wireless standard technologies with CP coverage.

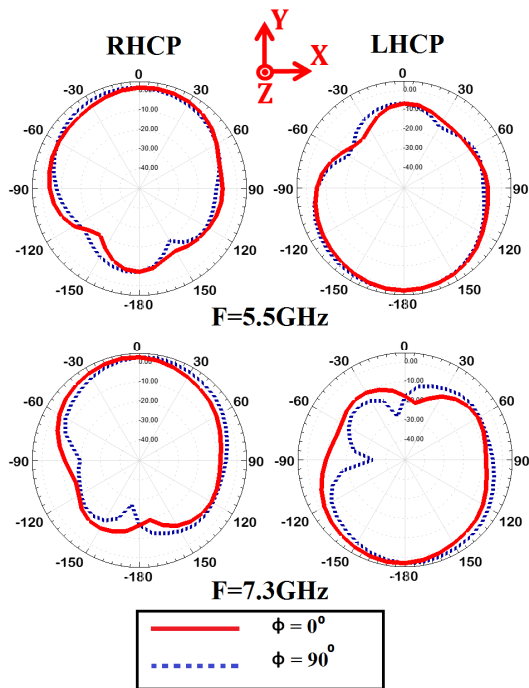


Fig. 7 Simulated radiation patterns of the proposed antenna at 5.5GHz and 7.3GHz

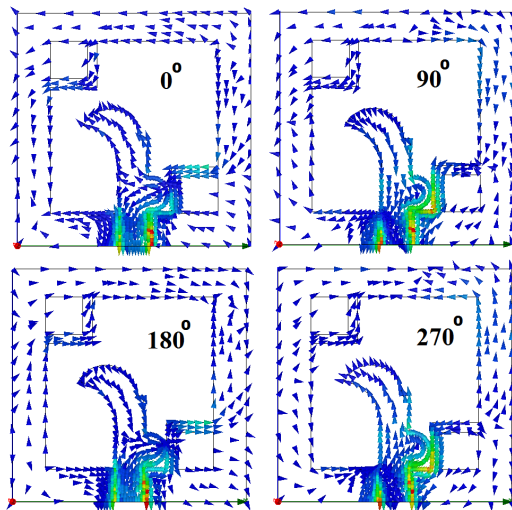


Fig. 8 Distribution of the surface current on the feed and ground plane of the CPSSA antenna at 6.8 GHz in 0°, 90°, 180°, and 270°

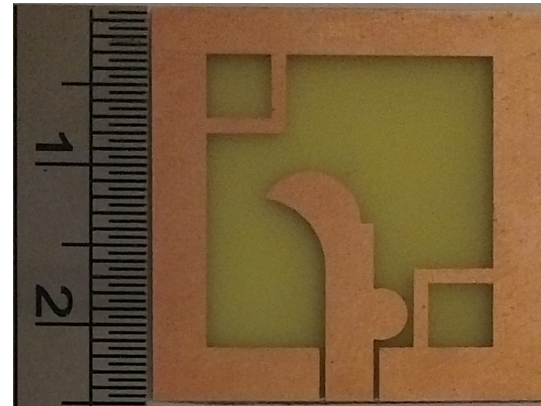


Fig. 9 Photograph of the realized antenna.

**References**

- [1] Javad Pourahmadazar, Ch. Ghobadi, J. Nourinia, Nader Felegari, and Hamed Shirzad, Broadband CPW-Fed Circularly Polarized Square Slot Antenna with Inverted-L Strips for UWB Applications. *IEEE Antenna Wireless Propag. Lett.*, vol. 10, pp. 369–372, 2011.
- [2] Jia-Yi sze, C-I. G. Hsu, Z-W.Chen, and C-C Chang, Broadband CPW-fed circularly polarized square slot antenna whit lightning shaped feed line and inverted-L grounded strips. *IEEE Trans Antenna Propag.*, vol. 58, no .3, pp. 973–977, Mar. 2010.
- [3] J-Y. Sze, K-L. Wong, and C-C . Huang, ” Coplanar waveguide-fed square slot antenna for broadband circularly polarized radiation”. *IEEE Trans. Antenna Propag.*, vol. 51,no. 8, pp. 2141–2144,Aug 2003.
- [4] C. Chen and E.K.N. Yung, ” Dual-band dual-sense circularly- polarized CPW-fed slot antenna with two spiral slots loaded,” *IEEE Trans Antenna Propag.*, vol. 57, no. 6, pp. 1829–1833, Jun 2009.
- [5] M.-J. Chiang, T.-F. Hung, and S.-S. Bor., “Dual-band circular slot antenna design for circularly and linearly polarized operations,” *Microw.Opt. Technol. Lett.*, vol. 52, no. 12, pp. 2717–2721, Dec. 2010.

9/6/2012

**Microleakage Evaluation of Two Different Nano-Restorative Materials in Primary Molars: *In Vitro* Study**Eman A. El-Ashiry<sup>1</sup>; Niveen S. Bakry<sup>2</sup>; Najat Farsi<sup>3</sup> and Deema Farsi<sup>3</sup><sup>1</sup>Preventive Dental Sciences Department, Faculty of Dentistry, King Abdulaziz University (Pedodontic Department, Faculty of Dental Medicine for Girls, El Azhar University).<sup>2</sup>Pediatric Dentistry Department, Faculty of Dentistry, Alexandria University.<sup>3</sup>Preventive Dental Sciences Department, Faculty of Dentistry, King Abdulaziz University  
[emanashkmm@yahoo.com](mailto:emanashkmm@yahoo.com)

**Abstract:** The aim of this *in vitro* study was to compare the microleakage values of a nano-resin modified glass ionomer, nano-composite alone and in contact with nano-resin modified glass ionomer base (sandwich technique) versus conventional-resin modified glass ionomer and conventional-composite in primary molars. **Methods:** Seventy five extracted primary molars were selected, and class V cavities were prepared on the buccal/lingual surfaces. Teeth were randomly distributed to 5 groups according to the type of restorative materials (n=15). Group 1: nano-resin modified glass ionomer (nano-RMGI) Group 2: nano-composite. Group 3: nano-resin modified glass ionomer (nano-RMGI) as a base followed by bonded nano-composite as a sandwich technique. Group 4: conventional-resin-modified glass ionomers (conv-RMGI). Group 5: conventional-composite. After thermocycling assessment of gap surface area was done. The teeth were immersed in basic fuchsin dye then sectioned and evaluated under a stereomicroscope. Microleakage was assessed using linear dye penetration in ( $\mu\text{m}$ ) and on a scale from zero to three. **Results:** There was statistically significant difference between the five groups gap surface area and gap surface fraction. Nano-RMGI /nano composite sandwich technique group exhibited the lowest value followed by nano composite group while conv-RMGI showed the highest value. Regarding linear dye penetration and microleakage scores, no significant differences were found between the tested materials. The degree of leakage in the gingival margins was significantly higher than that of occlusal margins for nano-RMGI, nano-RMGI / nano-composite and conv-RMGI groups. **Conclusion:** Complete marginal sealing could still not be reached with any of the tested restorative materials. Nano-RMGI / nano-composite sandwich technique showing the least microleakage followed by nano-composite when compared to the other four materials tested.

[Eman A. El-Ashiry; Niveen S. Bakry; Najat Farsi and Deema Farsi. **Microleakage Evaluation of Two Different Nano-Restorative Materials in Primary Molars: *In Vitro* Study.** Life Sci J 2012;9(3):2242-2250]. (ISSN: 1097-8135). <http://www.lifesciencesite.com>. 401

**Keywords:** Microleakage, nano composite, nano glass ionomer, primary teeth

**1. Introduction**

For many decades, silver amalgam has been the standard restorative material in pediatric dentistry. However, the detrimental environmental effects of mercury, debates on possible health effects of amalgam, and the growing interest of patient and parents in enamel-colored restorations have resulted in a considerable reduction in the use of amalgam in dentistry.<sup>1,2</sup> The most frequently used alternatives to amalgam for restoring primary teeth have been glass-ionomer cements,<sup>3</sup> resin modified glass-ionomer cements (RMGICs)<sup>4</sup>, compomers<sup>5</sup> and resin composites.<sup>6</sup>

Microleakage is a common problem in restorative dentistry. It is defined as the leakage of microorganisms and toxins between the restoration and walls of cavity preparation. It influences the restoration longevity leading to postoperative sensitivity, recurrent caries and negative pulpal sequelae.<sup>7</sup> Microleakage is considered mainly as the result of polymerization shrinkage. Techniques to reduce the effects of polymerization shrinkage in clinical practice

include incremental placement of light-curing composite resins<sup>8</sup>, sealing restoration margins with a 'glaze' of unfilled resin<sup>9</sup>, beveling enamel margins<sup>10</sup>, and use of staged light curing<sup>11</sup>. Other techniques involve use of the sandwich technique where a glass ionomer is placed as a base<sup>12</sup> or liner<sup>13</sup> with a bonded composite resin forming the outer, functional surface of the restoration. Tolidis et al<sup>14</sup> showed that use of an RMGI liner significantly reduced volumetric polymerization contraction for all the light-curing composite resin restorative materials tested.

The field of nanotechnology has expanded dramatically as nanostructured materials exhibit unique properties on the macroscale that offer high-potential technological benefits. Typically, the critical properties of nanomaterials are attributable to internal structures between 1 and 100 nanometers in dimension, defining the nano world. As size is decreased to nanoscale dimensions, physical properties, e.g. optical characteristics, get altered, especially when size nears the molecular scale, meaning < 5 nm. These unique properties are in the focus when research starts its

innovative work to achieve materials with greatest efficiencies.

In 2007, a new generation of RMGI was introduced. Ketac Nano (3M ESPE) is described by manufacturers as a nano-ionomer. It is based on a simplified dispensing and mixing system (paste/paste) that requires the use of a priming step, without separate conditioning step. Its primary curing mechanism is by light activation, and no redox or self curing occurs during setting.<sup>15</sup> Killian and Croll<sup>16</sup> showed that nano-ionomer and its improved properties make it an effective alternative for restoring primary and permanent teeth. Manufacturers claimed that Ketac Nano physical properties exceed those of other popular RMGI restoratives. The manufacturer reports that the nano filler and nanofiller clusters comprise approximately 60% of the glass component of Ketac Nano and are responsible for higher filling contents and accompanying enhancement in physical properties. It has better polishability than other RMGI restorative cements and fluoride ion dynamics comparable to other glass ionomer. The manufacturer's technical profile also states that in vitro tests have shown that Ketac Nano has the ability to act as fluoride reservoir and recharge the fluoride release after application of a topical fluoride source.<sup>16</sup>

Polymer nano-composite is another new class of material with unique internal structure and properties and contain nano fillers that are 0.005 to 0.01 micron in size. Dabanoglu et al<sup>17</sup> found that a high filler degree combined with small particle dimensions reduced abrasion by up to 50% compared to composites of lower filler degree or those with organic (pre-polymerized) filler. Furthermore, Mitra *et al.*,<sup>18</sup> measured nano composite properties, in vitro, in comparison with several existing composites (hybrids, microhybrids, and microfill). Nano-composite showed high translucency, high polish ability and retention similar to those of microfill while maintaining physical properties and wear resistance equivalent to

Apart from the obvious improvements in mechanical properties and user-friendliness, it is not clear how the addition of nano-fillers will influence the adhesiveness of resin modified glass ionomer and composite in primary teeth. Therefore, the aim of this study was to evaluate and compare marginal adaptation of class v in primary teeth restored with:

1. Nano-resin modified glass ionomer (Nano-RMGI)
2. Nano-composite
3. Nano-composite in contact with nano resin-modified glass ionomer liner (Nano RMGI/nano composite sandwich technique)
4. Conventional resin modified glass ionomer. (Conv-RMGI)
5. Conventional composite (Conv-composite)

## Materials and methods

### Selection and Preparation of Teeth:

A total of 75 extracted primary molars, due to caries or orthodontic reasons were collected for this study. The selected teeth needed to have at least three sound walls and one half to two thirds of root length. The teeth were debrided and stored in distilled water at room temperature.

### Cavity preparation:

Standardized class V cavity preparations were prepared in the middle third of each tooth on the buccal or the lingual surface, care was taken that cavity margins were surrounded by enamel. The cavity was prepared with # 330 carbide bur on a high-speed hand piece with water spray. The cavity preparation was oval in shape with dimensions approximately 3 mm mesiodistal width, 2 mm occlusogingival height and 1.5 mm axial depth (length of bur was used as guide for cavity depth)<sup>19</sup>. Each bur was replaced after five preparations. The dimensions were standardized by having the outline dimension cut on a matrix band figure (1). The cavo-surface walls finished to a butt joint.

## Restorative Materials

Table 1: Materials used. Group Materials	Product	Manufacturer
Nano- resin modified glass ionomer	- Ketac™ N100 (nanoRMGI)	3M ESPE Seefeld, Germany
-Nano composite	- Ketac™ supreme XT universal Restorative	3M ESPE Seefeld, Germany
-Conventional resin-modified glass ionomer	PhotacFil Seefeld,	3M ESPE (Aplicap) Germany
-Conventional composite resin	-Z-100 St. Paul,	3M Dental products Minn U.S.A.

### Cavity restoration

The teeth were randomly selected and assigned to one of the five experimental groups according to the restoration type (15 per group). Group I restored by nano- resin modified glass ionomer (Nano RMGI), group II restored by nano composite, group III restored by nano RMGI/nano composite sandwich technique, group IV restored by conventional resin-modified glass ionomer and group V conventional composite resin. Restoration of prepared teeth were done according to manufacturer instructions and cured by the same light-curing unit (POLYlux II, KaVoDental GmbH, KG, and Germany). All teeth were thermocycled for 500 cycles between 5° and 55°C with a dwell time of 30 seconds.<sup>20</sup>

#### Assessment of gap surface area

The gap surface area of each restoration were assessed. Photomicrograph was taken by CCD digital camera (Olympus-Japan) attached to zoom stereo microscope (Olympus SZ-PT-Japan) at magnification X15. A binary threshold of the desired area of gap was done. Surface area of the gap (measured by  $\mu\text{m}^2$ ) at the restoration / tooth interface along the entire circumference of the restoration outline was automatically calculated using the image analysis software (Imageware, Image 1.3-1b, USA). The surface area fraction of the gap surface area to the entire surface area of the restoration was calculated. All the recorded data were collected, tabulated and statistically analyzed.

#### Assessment of Microleakage

##### - Assessment of linear dye penetration

After detection of the gap surface area, the teeth were covered with yellow sticky wax to occlude all the openings and the teeth received 3 coats of a colorless nail varnish, except for a 1-mm window around restoration margins. Then specimens were immersed in 0.5 % basic fuchsin solution for 24 hours at room temperature. Samples were rinsed with distilled water to remove excess dye, and then sectioned in a buccolingual direction through the center of each restoration with a water cooled diamond disc to avoid overheating and cracking of restorations.

The area of the restoration was captured by a CCD digital camera (DP10, Olympus, Japan) mounted on Zoom stereo microscope (Olympus SZ-PT-Japan) at a magnification 30x. Digital images were then transferred to a computer system. They were analyzed using the image analysis software (ImageJ, 1.31b, USA).

The linear dye penetration is measured in microns of each section from the outer surface into enamel or/and dentin was automatically calculated using the same software for both the occlusal and the gingival margins. Moreover, the percentage of the linear dye penetration (occlusally and gingivally) to

the entire length of occlusal or gingival margins was calculated.<sup>21</sup>

#### Assessment of Microleakage scores

Microleakage was assessed also by scoring the degree of linear dye penetration in the tooth / restoration interface. The degree of dye penetration was identified according to ISO specification 11405:2003,<sup>22</sup>.

0=no dye penetration.

1= dye penetration to the enamel aspect of preparation wall.

2= dye penetration to the dentin aspect of the preparation wall, but not including the pulpal floor.

3= dye penetration including the pulpal floor of the preparation

Both sections of each restoration were scored and the section with the greatest amount of microleakage was recorded as the score of that restoration. Microleakage scores were recorded for both the occlusal and the gingival margins. Two investigators examined the teeth independently. If the scores were different discussion took place till agreement.

#### Statistical analysis:

Descriptive statistics were displayed as means and standard deviations for quantitative variables and frequencies and percents for qualitative variables. Mean gap surface area and mean gap surface area fraction were checked for normality and found to be normally distributed. Means were compared among groups using analysis of variance (ANOVA).

Percentage of linear dye penetration was checked and found to be non normally distributed. Comparison of mean die penetration and microleakage scores among the study groups was done using Kruskal Wallis test whereas comparison in the same group between the occlusal and the gingival aspects was done using Wilcoxon signed ranks test.

Significance level was set at  $P < 0.05$ .

### 3. Results

This study was carried out on 75 human clinically sound a naturally exfoliated primary molars. Standardized class V cavity preparations were prepared in the cervical third of each tooth on the buccal or lingual surface surrounded by enamel. The prepared teeth were classified into five equal groups, 15 specimens each, according to the type of restoration used.

Assessment of gap surface area at restoration / tooth interface in microns<sup>2</sup>, linear dye penetration in microns and microleakage scores were done. All recorded data were tabulated and statistically analyzed.

#### Assessment of Gap Surface Area

For each restoration a photo micrograph was taken by CCD digital camera attached to zoom stereomicroscope at magnification x15. A binary

threshold of the desired area of gap was done figure (2). A surface area of gap in  $\mu\text{m}^2$  at restoration / tooth interface along the entire circumference of the restoration outline was calculated using image analysis software. The gap surface area fraction of the gap surface area to the entire surface area of the restoration was also calculated.

Table (2) figures (2, 3) show the comparative analysis of the mean gap surface area ( $\mu\text{m}^2$ ) and the mean gap surface area fraction for the tested restorative materials.

The mean gap surface area of nano- RMGI (group I) was (71355.54 $\pm$ 36161.06), nano composite (group II) was (57674.73 $\pm$  43554.24), group(III) Nano RMGI /Nano composite sandwich technique was (42269.87 $\pm$  11978.07), group (IV) Conv-RMGI was (74649.46 $\pm$  44308.64) and for Conv-composite was (85124.46 $\pm$  45875.51). The results revealed that there

was statistically significant difference between the five tested groups ( $P=0.015$ ) regarding the mean gap surface area, at a significance level of ( $P < 0.05$ ).

For the mean gap surface area fraction of Nano-RMGI, Nano composite, Nano RMGI /Nano composite sandwich technique, Conv-RMGI and Conv-composite were (0.536 $\pm$  0.3973), (0.422 $\pm$  0.356), (0.390 $\pm$  0.337), (0.618  $\pm$  0.421) and (0.827 $\pm$  0.408) respectively. Also, there was statistically significant difference between the five tested groups ( $P=0.021$ ).

It is clear that nano RMGI /nano composite sandwich technique group, had the least the mean gap surface area and the mean gap surface area fraction followed by nano composite group, while conv-composite group, had the highest one.

**Table (2): Comparative analysis of the mean gap surface area and the mean gap surface area fraction among the tested restorative materials**

Dependent Variable	Nano-RMGI	Nano composite	Nano RMGI /Nano composite	Conv-RMGI	Conv-composite	ANOVA <i>P</i> value
Number of teeth	15	15	15	15	15	
Gap surface area ( $\mu\text{m}^2$ )	71355.54 $\pm$ 36161.06	57674.73 $\pm$ 43554.24	42269.87 $\pm$ 11978.07	74649.46 $\pm$ 44308.64	85124.46 $\pm$ 45875.51	0.016*
Gap surface area fraction	0.536 $\pm$ 0.3973	0.422 $\pm$ 0.356	0.390 $\pm$ 0.337	0.618 $\pm$ 0.421	0.8267 $\pm$ 0.408	0.021*

\* Statistically significant at  $P < 0.05$

#### Assessment of the linear dye penetration

Table (3), figures (4,5,6,7,8) demonstrates the comparative analysis for the mean of the linear dye penetration percentage both occlusally and gingivally among the tested restorative materials.

It is clear that, nano RMGI/nano Composite sandwich technique group showed the least degree of microleakage as they had the least mean linear dye penetration percentage both occlusally and gingivally restorations (12.84 $\pm$ 8.00), (20.87 $\pm$ 10.92) followed by nano composite group (14.62 $\pm$  4.94), (21.83 $\pm$  13.10), while conv-composite group were the highest where the mean of linear dye penetration percentage occlusally and gingivally were (20.63 $\pm$  21.22), (29.51 $\pm$  24.65) respectively. For Nano RMGI group the mean of linear dye penetration percentage occlusally and gingivally were (16.55 $\pm$  7.42), (27.32 $\pm$

10.31) and for Conv-RMGI were (16.28 $\pm$  6.10), (29.24 $\pm$  11.63) respectively.

Although there were differences among the five groups of restorative materials for the mean occlusal and gingival linear dye penetration percentage, that differences were not statistically significant as they were ( $P=0.42$ ) ( $P=0.35$ ) at the significance level  $P < 0.05$ .

Also, the results revealed that there is statistically significant differences of the mean linear dye penetration percentage between the occlusal and gingival margins for some tested groups as in the nano RMGI/nano composite sandwich technique group ( $P=0.03$ ), nano RMGI group ( $P=0.03$ ) and conv-RMGI group ( $P=0.001$ ) at the significance level  $P < 0.05$ .



**Table (3): Comparative analysis of the mean linear dye penetration percentage both occlusally and gingivally between the tested restorative materials.**

Dependent Variable	Nano RMGI	Nano composite	Nano RMGI / Nano composite	Conv-RMGI	Conv-Composite	P. value
Mean Linear Occlusal Dye Penetration Percentage	16.55 ± 7.42	14.62 ± 4.94	12.84 ±8.00	16.28 ± 6.10	20.63 ± 21.22	0.42
Mean Linear Gingival dye penetration percentage	27.32 ± 10.31	21.83 ± 13.10	20.87 ±10.92	29.24 ± 11.63	29.51 ± 24.65	0.35
P value	0.003*	0.06	0.03*	0.001*	0.30	

\* Statistically significant at  $P < 0.05$

#### Assessment of the microleakage scores

The comparative analysis of the microleakage scores at both occlusal and gingival margins were shown in table (4) (figures 4,5,6,7,8). None of the restorative materials showed occlusal or gingival dye penetration along the pulpal (axial) wall, score (3) microleakage. It was observed that (Nano-RMGI / nano composite) sandwich technique group showed the least degree of microleakage scores, followed by nano-composite group, meanwhile the conv-

composite group showed the highest microleakage scores. There was no significant difference ( $P=0.12$ ) in the amount of microleakage scores at occlusal or gingival margins for nano-RMGI / nano composite sandwich technique group, nano-composite group or conv-composite group. However, the difference between the occlusal and gingival margins showed a statistically significant difference of nano-RMGI group ( $P=0.04$ ), and conv-RMGI group ( $P=0.003$ ).

**Table (4): Comparative analysis of the microleakage scores among the tested restorative groups at the occlusal and gingival margins**

Aspects		Nano-RMGI	Nano-composite	Nano RMGI / nano-composite	Conv-RMGI	Conv-Composite	P. value
Occlusal	Score	1 (6.7%)	2 (13.3%)	5 (33.3%)	1 (6.7%)	3 (20%)	0.12
	Score	13 (86.7%)	13 (86.7%)	9 (60%)	14	9 (60%)	
	Score	1 (6.7%)	0	1 (6.7%)	0	3 (20%)	
	Score	0	0	0	0	0	
Gingival	Score	1 (6.7%)	1 (6.7%)	1 (6.7%)	0	1 (6.7%)	0.56
	Score	7 (46.7%)	11 (73.3%)	11 (73.3%)	7 (46.7%)	9 (60%)	
	Score	7 (46.7%)	3 (20%)	3 (20%)	8 (53.3%)	5 (33.3%)	
	Score	0	0	0	0	0	
	P.	0.04*	0.17	0.15	.003*	0.47	

\* Statistically significant at  $P < 0.05$

#### 4. Discussion

There have been more changes and developments in dentistry over the past decade. In the current age of adhesive dentistry or microdentistry, conservation of tooth structure is paramount. Rather than using extension for prevention as a treatment guideline, emphasis now is placed on restriction with conviction.

Microleakage is the major problem in clinical dentistry. The longevity of the restoration is largely determined by marginal sealing of the cavity. Achieving a micromechanical and biomechanical

bond between the restoration and tooth is considered effective and a standard procedure in clinical practice. The ability of a restoration to minimize the extension of microleakage at the tooth/ restoration interface is important in predicting its clinical success. Numerous investigations have used a variety of research tools to evaluate the extent of microleakage and the marginal integrity of restorations. The use of dye diffusion is one of the most commonly used methods.<sup>23-25</sup>

In the present study, the evaluation and the comparison of the microleakage of the restorative materials were done *in vitro*. We choose class V

preparations to study the behavior of the tested restorative materials in a high C-Factor design (preparations with high ratio of bonded “flow-inactive” to free “flow-active” surfaces). Moreover, we selected the butt joint enamel margin to comply with traditional enamel cavity margin designs advocated for most posterior restorations.

Thermocycling has been used in this study to simulate oral conditions. It is a method widely used in dental research, particularly when testing the performance of adhesive materials. It aims at thermally stressing the adhesive joint at the tooth/restoration interface by subjecting the restored teeth to extreme temperatures compatible with temperatures encountered intraorally. This process may highlight the mismatch in thermal expansion between the restoration and tooth structure, resulting in different volumetric changes during temperature changes and causing fatigue of the adhesive joint with subsequent microleakage. This is in agreement with other researches which stated that, thermo-cycling mimic intra-oral temperature variations and subjecting the restorations on the tooth to temperature extremes compatible with oral cavity. In the absence of a definite recommendation for number of cycles needed to simulate oral conditions 500 cycles was applied in this study. The number of cycles reported in previous studies range from 300 to 5000.<sup>20,26-28</sup>

The results of the present study revealed that there was statistically significant difference between the five groups regarding gap surface area and gap surface fraction ( $P=0.016,0.021$ ). Nano-RMGI /nano composite sandwich technique group exhibited the lowest value followed by nano composite group while conv-composite showed the highest value.

Also analysis of the obtained data of this *in vitro* study concluded that, none of the tested restorative materials completely eliminate microleakage at the occlusal or gingival margins. Assessment of the linear dye penetration fraction and the microleakage scores showed that Nano -RMGI /nano composite sandwich technique group had the best results that they had the least linear dye penetration and the best control of microleakage, the second one was nano composite group. In contrast, conv-composite showed the greatest linear dye penetration and microleakage measures compared with other restorative groups in the present study. This can explained by that conv-composites shrink more than nan-ocomposite as they have lesser filler loading and a greater proportion of resin matrix. The difference in coefficient of thermal expansion and elastic modulus between the composite and dentin causes stress in the interfacial gaps contributing to microleakage. This is in agreement with Tolidos *et al.*,<sup>14</sup> who found that resin modified glass ionomer liner significantly reduce volumetric polymerization contraction for all the light-curing

composite resin restorative materials tested. Croll and Cavanaugh<sup>29</sup> reported that properties of light-hardened glass ionomer cements makes them ideal dentin replacement and properties of composite makes them ideal enamel replacement. When used together, the properties of each material are maximized and the resulting restoration simulates the tooth form and function. In addition, Dabanoglu *et al.*,<sup>17</sup> has suggested that nano- composite has high filler degree and spherical nano particles that reduces organic matrix content and gave a hard surface compared to conventional composite. This quality would also improve its wear and abrasion resistance and enhance the marginal seal to enamel.<sup>30</sup> Hedge *et al.*,<sup>31</sup> compared microleakage in three different composite resins (nano- composite, nano- ceramic composite and nano-hybrid composite) in class V in permanent teeth. Although there was no statistical difference between the three groups, nano-composite showed the least mean leakage values.

The results of the present study showed that conv-RMGI group also showed low leakage level occlusally than nano-RMGI group. This finding is in consistence with Coutinho *et al.*,<sup>32</sup> who showed that nano-RMGI bonded less effectively than conv-RMGI.

With respect to the cavity margins evaluated in this study, there was no significant difference between the occlusal and gingival margins for nano composite and conv - composite. A suitable explanation for such results may be the fact that gingival wall was located in enamel. The use of etch-bond technique improved the composite bond to enamel gingivally. This was in agreement with Fahmy and Farag<sup>33</sup> who evaluated gingival microleakage in class II cavities in primary molars restored with nano hybride composite using three different techniques (total bonding, closed or open sandwich technique). The best gingival marginal seal was obtained with the total bonding technique.

On the other hand there were significant differences between the occlusal and gingival margins for nano-RMGI, nano-RMGI / composite sandwich technique and conv -RMGI. According to Croll and Cavanaugh<sup>29</sup>. RMGI including nano-RMGI bond to enamel and dentin through both chemical and micromechanical bonding mechanism. RMGI due to lack of an additional conditioning step might show more gingival leakage because of the superficial mechanical interlocking.<sup>30</sup> Moreover, Fakhri *et al.*,<sup>34</sup> support the conclusion that the difference in mineral content and a prismatic layer thickness may account for the difference in microleakage between the occlusal and gingival margins in primary teeth.

### Conclusion

Within the experimental results of this in vitro study, the following conclusions were drawn:

- Nano- RMGI /nano composite sandwich technique exhibiting the best control of marginal leakage followed by nano composite. The conv-Composite, however, showed the highest microleakage values.
- For (nano -RMG), (nano- RMGI / nano composite) and (conv-RMGI), microleakage was higher at the gingival margin.
- Statistical significant differences were found between the five restorative groups
- regarding gap surface area and gap surface area fraction while no statistical significant differences were found in degree of microleakage between the five groups regarding the linear dye penetration fraction or microleakage scores.
- The results of this study potentiate the importance of using liners under nano- composite restorations.

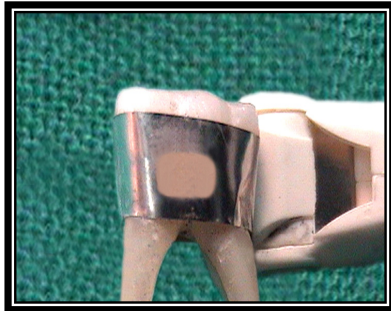


Fig (1): Standardized Class V Cavity preparation.

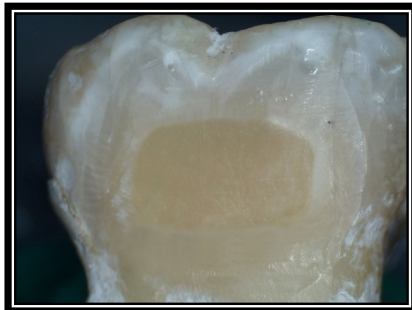


Fig (2): The photomicrograph shows a specimen of Nano Composite group before sectioning with magnification X15.



Fig (3): The previous photomicrograph after binary thresholding of the area of gap at the restoration/tooth interface. This area is then automatically calculated.

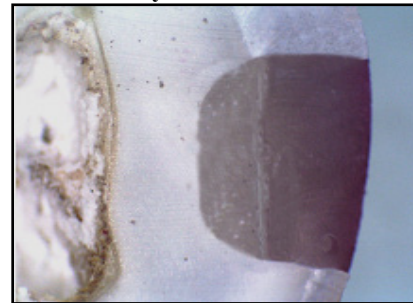


Fig (4): A Photomicrograph of Nano RMGI /Nano Composite sandwich restoration showing score 0 occlusally and score 0 Gingivally.

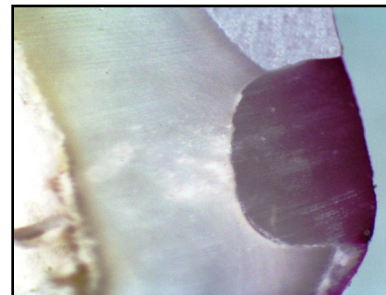


Fig.(5): A Photomicrograph of Nano Composite restoration showing score 1 occlusally and score 1 Gingivally.

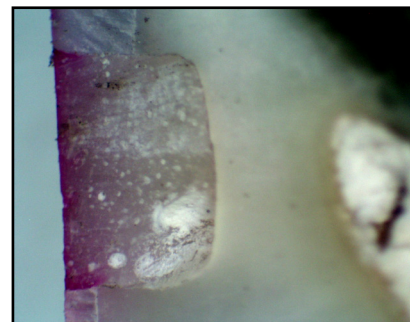
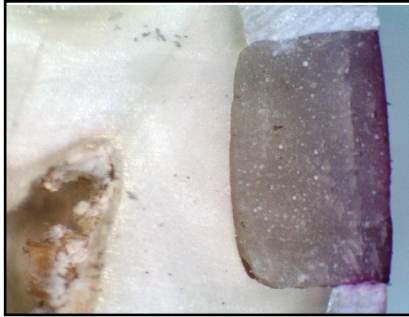


Fig.(6): A Photomicrograph of Nano RMGI restoration showing score 1 occlusally and score 1 Gingivally



**Fig.(7): A Photomicrograph of Conv-RMGI restoration showing score 0 occlusally and score 2 Gingivally.**

#### Acknowledgement

This project was funded by the Deanship of Scientific Research (DSR) King Abdulaziz University, Jeddah, under grant number 185/254/1431. The author therefore acknowledge with thanks DSR for the technical and financial support.

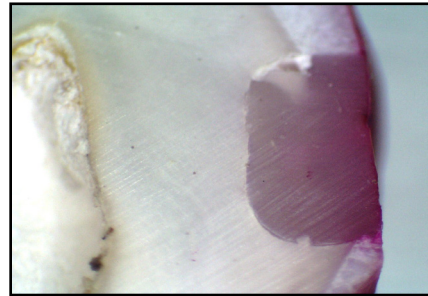
#### Corresponding author

**Eman A. El-Ashiry**

Preventive Dental Sciences Department, Faculty of Dentistry, King Abdulaziz University (Pedodontic Department,  
[emanashkmm@yahoo.com](mailto:emanashkmm@yahoo.com)

#### References

1. Lutz F, Krejci I. Amalgam substitute: A critical analysis. *J Esthet Dent.* 2000;12:146-157.
2. Hübel S, Mejáre I. Conventional versus resin-modified glass ionomer cement for class II restorations in primary molars. A 3-year clinical study. *Int J Paediatr Dent.* 2003; 13:2-8.
3. Croll TP and Nicholson JW. Glass ionomer cements in pediatric dentistry: review of literature. *Pediatr Dent.* 2002; 24:423-29.
4. Tyas MJ, Burrow MF. Clinical evaluation of a resin-modified glass ionomer adhesive system: results at five years. *Oper Dent.* 2002; 27(5):438-41.
5. Iazzetti G, Burgess JO, Gardiner D. Selected mechanical properties of fluoride-releasing materials. *Oper Dent.* 2001; 26:21-26.
6. Combe EC, Burke FJT. Contemporary resin-based composite materials for direct placement restorations: packable, flowable, and others. *Dent Up.* 2000; 27:326-36.
7. Burgess JO, Walker R, and Davidson JM. Posterior resin-based composite: review of literature. *Pediatr Dent.* 2002; 24:465-479.
8. Jedrychowski J, Bleier R, Caputo A. Shrinkage stresses associated with incremental composite



**Fig.(8): A Photomicrograph of Conv-composite restoration showing score 1 occlusally and score 2 Gingivally**

filling techniques. *ASDC J Dent Child,* 1998;65:111-15.

9. Tjan AHL, Tan DE Microleakage at gingival margins of Class V composite resin restorations rebonded with various low viscosity resin systems. *Quintessence Int.* 1991; 22: 565-573.
10. Han L, Okamoto A, Iwaku M. The effects of various clinical factors on marginal enamel microcracks produced around composite restoration. *Dent Mater.* 1990;11: 26-37.
11. Ernst CP, Brand N, Frommator U, Rippin G, Willershausen B. Reduction of polymerization shrinkage stress and marginal microleakage using soft-start polymerization. *J Esthet Restor Dent.* 2003;15(2):93-103.
12. McLean JW, Powis DR, Prosser HJ, Wilson AD. The use of glass ionomer cements in bonding composite resins to dentine. *Br Dent J.* 1985; 158: 410-14.
13. Kemp-Scholte CM and Davidson CL. Complete marginal seal of Class V resin composite restorations effected by increased flexibility. *J Dent Res.* 1990; 69: 1240-43.
14. Tolidis K, Nobecourt A, Randall A. Effect of a resin-modified glass ionomer liner on volumetric polymerization shrinkage of various composites. *Dent Mater* 1998; 14:417-23.
15. Moshaverinia A, Ansari S, Movasaghi Z, Billington RW, Darr JA, Rehman IU. Modification of conventional glass-ionomer cements with N-vinylpyrrolidone containing polyacids, nano-hydroxy and fluoroapatite to improve mechanical properties. *Dent Mater.* 2008;24(10):1381-90.
16. Killian CM and Croll TP. Nano-ionomer tooth repair in pediatric dentistry. *Pediatr Dent.* 2010;32:530-5.
17. Dabanoglu A, Kunzemann KH, Hickel R, Korary F. Three bodies wear resistance of resin composite. EFCD Conference, Munich, 2003.

18. Mitra SB, Wu D, and Holmes BN. An application of nanotechnology in advanced dental materials. *J Am Dent Assoc.*, 2003;134(10):1382-90
19. Wadenya RO, Yego C, Mante FK. Marginal microleakage of alternative restorative treatment and conventional Glass ionomer restorations in extracted primary molars. *J Dent Child* 2010;77:32-35.
20. Wahab FK, Shaini FJ, Morgano SM. The effect of thermocycling on microleakage of several commercially available composite class V restorations *in Vitro*. *J Prosthet Dent.* 2003 ; 90 (2): 168-74.
21. Borsatto MC, Corona SA, Chinelatli MA, Ramos R *et al.*, Comparison of marginal microleakage of flowable composite restorations in primary molars prepared by high-speed carbide bur, Er:YAG laser, and air abrasion. *J Dent Child.* 2006;73:122-26.
22. International Standards Organization. ISO standard 11405:2003. Dental materials—testing of adhesion to tooth structure. Geneva: ISO/TS, 2003. Available at: "<http://www.iso.ch/iso/en/prods-services/ISOstore/store.html>". 2d Edition, 2003-01-20.
23. **Pilo R, Ben-Amar A.** Comparison of microleakage for three one-bottle and three multiple-step dentin bonding agents. *J Prosthet Dent.* 1999 Aug;82(2):209-13.
24. Del Nero MO, de la Macorra JC. Sealing and dentin bond strengths of adhesive systems. *Oper Dent.* 1999 Jul-Aug;24(4):194-202.
25. Van Meerbeek B, De Munck J, Yoshida Y *et al.*, Adhesion to enamel and dentin :Current status and future challenges. *Oper Dent.* 2003;28;215-35.
26. Duangthip D, Lussi A. Microleakage and penetration ability of resin sealant versus bonding system when applied following contamination. *Pediatr Dent.* 2003;25:505-11
27. Gupta KV, Pradhuman, Verma and Trivedi A. Evaluation of Microleakage of Various Restorative Materials: An *in Vitro* Study *J Life Sci,* 3(1): 29-33 (2011).
28. de Moraes PM, Rodrigues Junior AL, Pimenta LA. Quantitative microleakage evaluation around amalgam restorations with different treatments on cavity walls. *Oper Dent.* 1999 ;24 :217-22.
29. Croll TP, Cavanaugh RR. Posterior resin-based composite restoration :A second opinion. *J Esthet Restor Dent.*, 2002;14:303-12.
30. Geraldini S, Perdigao J. Microleakage of a new restorative system in posterior teeth. *J Dent Res* 2003 (special issue A):126.
31. Hegde MN, Vyrapake P, Shetty S, A comparative evaluation of microleakage of three different newer direct composite resins using a self etching primer in class V cavities :An *in vitro* study. *J Conserv Dent.* 2009;12(4):160-163
32. Coutinho E, Cardoso MV & De Munck J. (2009) Bonding effectiveness and interfacial characterization of a nano-filled resin-modified glass-ionomer *Journal of Dental Material* 25 :1347-1357.
33. Fahmy AE & Farrag NM (2010) Microleakage and shear punch bond strength in class II primary molars cavities restored with low shrink silorane based versus methacrylate based composite using three different techniques *Journal of Clinical Pediatric Dentistry* 35:173-181.
34. Fakri M, Seraj B, Shahrabi M, Motahary P & Hooshmand T (2009). Effect of salivary contamination on microleakage of resin composites placed with self etch adhesive in primary teeth: An *in vitro* study *Journal of Pediatric Dentistry* 31:334-339.

9/20/2012

## Nerve Conduction Velocity of Sciatic Nerve in High Fat Diet Induced Obesity in Rats: Effect of Corn Oil and Omega 3 Fatty Acids Supplement

Laila Ahmed El sayed, Samah Elattar, and Nashwa Eltablawy

Department of Physiology, Faculty of Medicine, Cairo University, Cairo, Egypt  
[omarattar1993@yahoo.com](mailto:omarattar1993@yahoo.com)

**Abstract: Background:** Obesity is a major susceptibility factor leading to the development of various conditions of the metabolic syndrome. In obese rats, slowing of motor nerve conduction velocity was observed. Fatty acids metabolism disturbance is very important in the occurrence of peripheral neuropathy. The aim of this work is to consider the role that balanced diets high in omega 6&9 PUFA (corn oil) or supplying rats with omega 3, play in modulating the impaired nerve function in obese rats. **Methods:** Thirty two adult male albino rats were randomly assigned to receive normal chow (NC) (n=8) or high fat diet HFD (n=24), for 12 weeks. After 12 weeks, body weight and body mass index(BMI) were measured and the NC group(n=8) continue their normal chow diet, **Group 1 (NC)** and served as a control group and the obese rats were randomly divided into 3 groups, 8 rats each: **Group 2:** Ob + HFD group, they continue their high animal fat diet, **Group 3:** Ob+HFD + corn oil group, they are obese rats received high fat diet containing corn oil and **Group 4:** Ob + HFD + Omega 3 group, they are obese rats, fed high animal fat diet supplemented with omega 3 (0.4 g/kg) daily. After five weeks, the final body weight was measured and BMI was calculated and blood samples were collected for measuring fasting plasma glucose level and insulin level and homeostasis model assessment of insulin resistance (HOMA-IR) test were evaluated. Plasma cholesterol, triglycerides and free fatty acids (FFAs) were measured. The rats were then killed and sciatic nerves were carefully dissected for measuring the nerve conduction velocity (NCV). Superoxide dismutase activity (SOD), malondialdehyde (MDA) and tumor necrosis factor alpha (TNF $\alpha$ ) were estimated in the nerve tissue of the 4 groups. **Results:** The results of this study showed a significant increase of body weight (gm) and BMI (kg/m<sup>2</sup>) in high fat diet group ( $p < 0.05$ ) after 12 weeks of the start of the diet when compared to the control group (NC). There were significant elevations in the final weight (gm) and BMI (kg/m<sup>2</sup>), a significant elevation in insulin level ( $\mu$ IU/l) and HOMA-IR test, a significant increase in nerve malondialdehyde (MDA), and tumor necrosis factor alpha (TNF $\alpha$ ) and a significant decrease in superoxide dismutase activity (SOD) and nerve conduction velocity (NCV) (m/s) after 5 weeks of high fat diet in (Ob+HFD) group, when compared to NC group. Changing diet composition for 5 weeks in Ob+ HFD+corn oil and Ob+HFD+omega 3 groups, did not induce any significant variation in body weight, BMI, or fasting blood glucose level as compared to Ob+HFD group. Insulin level ( $\mu$ IU/l) and HOMA-IR test were significantly decreased in Ob+ HFD+corn oil and Ob+HFD+omega 3 groups compared to Ob+HFD group. Plasma cholesterol levels (mg/dl), triglycerides (mg/dl), and free fatty acids (FFA) (mmol/l) were significantly decreased after 5 weeks diet in Ob+ HFD+corn oil or Ob+HFD+ Omega 3 groups when compared to mean values of Ob+HFD group. Tissue malondialdehyde (MDA) and tumor necrosis factor alpha (TNF $\alpha$ ) were significantly decreased but superoxide dismutase (SOD) activity was significantly increased in Ob+HFD+corn oil and Ob+HFD+omega3 groups compared to Ob+HFD. NCV(m/s) in Ob+HFD+ corn oil group was significantly increased compared to Ob+HFD and their values in Ob+HFD+ corn oil group showed no significant variation as compared to NC group. While there was a significant increase in NCV in Ob+ HFD+Omega 3 group as compared to Ob+ HFD group, there was still a significant decrease compared to NC group. **Conclusion:** The results of this study may have important clinical and speculative implications. Corn oil or omega 3 supplementation may be effective in obesity induced neuropathy. The mechanism of their effects is multifactorial including improving insulin sensitivity, correction of dyslipidemia, reducing oxidative stress and an anti-inflammatory effect. This possibility should be carefully considered and examined in future trials of essential fatty acid supplementation.

[Laila Ahmed El sayed, Samah Elattar, and Nashwa Eltablawy. Nerve Conduction Velocity of Sciatic Nerve in High Fat Diet Induced Obesity in Rats: Effect of Corn Oil and Omega 3 Fatty Acids Supplement. *Life Sci J* 2012;9(3):2251-2264] (ISSN:1097-8135). <http://www.lifesciencesite.com>. 402

**Key words:** nerve conduction velocity, obesity, oxidative stress, inflammation, corn oil, omega3, insulin resistance.

### 1. Introduction

Obesity is a pathological condition in which excess body fat has accumulated to the extent that it may have an adverse effect on health, leading to

reduced life expectancy and/or increased health problems [1]. Obesity is a major susceptibility factor leading to the development of various conditions of the metabolic syndrome. A recent study from the

World Health Organization approximates that, globally, 1.6 billion adults are overweight with at least 400 million adults classified as obese [2].

In obese rats, slowing of motor nerve conduction velocity was observed. Obese Zucker rats develop neural deficits independently of hyperglycemia [3]. Evidence for the development of neuropathic changes at the prediabetic stage, prior to development of overt hyperglycemia and diabetes mellitus, is emerging from both clinical [4] and experimental [5] studies. The pathophysiologic basis of this relationship is not well understood. A number of pharmacological agents that showed promise in animal studies have been withdrawn from clinical trials because of a lack of efficacy or adverse side-effects [6].

The induction of obesity may be performed in animals by neuroendocrine, dietary or genetic changes. [7]. High-fat diet (HFD)-fed rats with alimentary obesity and hyperinsulinemia, develop nerve conduction velocity deficit, therefore, represent an ideal model for evaluating effects of changing dietary composition on manifestations of neuropathy[8]. The contributions of insulin resistance, hypertriglyceridemia and/or increased nonesterified fatty acids (NEFA), and hypercholesterolemia to this condition remain unknown [9].

Fatty acids metabolism disturbance is very important in the occurrence of peripheral neuropathy. Low plasma omega-6 and omega-3 fatty acids levels were associated with accelerated decline of peripheral nerve function with aging [10]. Evidence has emerged suggesting that both omega-6 and omega-3 fatty acids are also important for peripheral nerve health and function [11].

The administration of unsaturated fatty acids especially omega-3 has gained considerable attention recently. The effect of omega-3 fatty acid on the treatment of coronary arteries atherosclerosis has been shown [12]. Consumption of Omega-3 fatty acids in animal models could be effective in restoring nerve conduction velocity [13]. Also, omega 6&9 poly unsaturated fatty acids (PUFA) supplied from corn oil has also been reported to be beneficial in systemic diseases, such as hypertension [14], cardiovascular disease [15] and cancer [16], however, little is known about the possible benefits that dietary omega-3 or omega 6&9 may have for the nerve conduction disorders in obesity. In this study, we propose that the lipid changes associated with obesity might partially explain the reported neural dysfunction. We consider the role that balanced diets high in omega 6&9 (corn oil) or supplying rats with omega 3, can have in modulating the impaired nerve function in obese rats.

## 2. Material and methods

### Experimental animals and groups

Thirty two adult male albino rats of body weight 80-100 gm, 3 to 4 weeks old, were included in this study. The rats were supplied by the Animal House Unit of Kasr Al-Ainy, Faculty of medicine, Cairo University, housed in cages at room temperature with normal light & dark cycle. The rats were randomly assigned to receive normal chow; control group (NC) [16] (n=8), and HFD [17] (n=24), for 12 weeks. The composition of the different experimental diets used is shown in table 1.

**Table 1:** The composition of experimental diets

Ingredients Contents (g/kg diet)	HFD (animal fat)	HFD (animal fat) +corn oil	Control diet (NC)
Carbohydrates			
-Corn starch	100	100	480
-Sucrose	100	100	100
Fats			
- Soybean oil	50	50	50
- Animal fat	500	300	120
- Corn oil		200	
Protein			
- Casein	190	190	190

This study was carried out in the Physiology and Biochemistry Departments, Faculty of Medicine, Cairo University. After 12 weeks, the rats were classified into:

**Group 1:** they are the normal rats, received normal chow and served as normal control. They continued free access to laboratory rat chow and tap water and received 4 mL of normal saline through gavage daily for another 5 weeks (NC). The HFD-fed rats were divided into 3 groups, 8 rats each:

**Group 2:** Ob + HFF group, they are obese rats those continue their high animal fat diet and received 4 mL of normal saline through gavage for 5 weeks.

**Group 3:** Ob +HFD+ corn oil group, they are obese rats, received high fat diet. In this group of rats, corn oil was administered as 20% of the diet, replacing same percent of animal fat and received 4 mL of normal saline through gavage daily. Corn oil contains high omega 6&9 polyunsaturated fat [18]. FA analysis of corn oil showed that corn oil contained mono unsaturated fatty acids (27.576%), poly unsaturated fatty acids (PUFA) (57.36%),

omega 6 (58%) and omega 9 (28%), fatty acids in the percent shown in table 2 [19].

**Table 2:** The fatty acid analysis of corn oil

	Saturated fatty acids	MUFA	PUFA	Omega 3	Omega 6	Omega 9
<b>Corn oil</b>	12.948	27.576	57.36	1	58	28

Values are expressed as weight percent (%) of total fat.

**Group 4:** Ob + HFD + Omega 3 group, they are obese rats, fed high fat diet rich in saturated animal fat for 5 weeks and received omega 3 (0.4 g/kg BW) daily through gavage [20]. Each Omega-3 capsule contains Fish Oil (Omega-3 Docosahexaenoic acid DHA 12%, eicosapentaenoic acid EPA 18%) 999 mg, Vitamin E 1 mg, Gelatin (food grade) 371 mg. Alpha tocopherol is included in the capsule to avoid auto-oxidation.

#### **Weight measurements:**

All rats were weighed in grams and naso-anal lengths were measured in cm at the end of the 12-weeks study and at the end of the 5 weeks of different diet trial. The body mass index (BMI) was calculated (by dividing the body weight in kilograms by the length in meters squared) [21] at the end of the study period (after 12 weeks of NC or HFD and after 5 weeks of corn oil or omega 3 supplementation).

Rats were fasted overnight for at least 6 hours and blood samples were obtained by introducing a fine heparinized capillary tube at the inner canthus of the eye into the venous plexus. The blood samples were delivered into centrifuge tubes to which anticoagulant was added then centrifuged at 10,000 rpm for 20 minutes and plasma was separated and stored at -70°C for measuring fasting blood glucose level and insulin level and HOMA-IR test were evaluated. Plasma cholesterol, triglycerides and FFAs were measured. The rats were then killed and sciatic nerves were carefully dissected for measuring of nerve conduction velocity, tissue superoxide dismutase activity (SOD), malondialdehyde (MDA) and tumor necrosis factor alpha (TNF $\alpha$ ).

#### **Biochemical measurements**

##### **Measurement of fasting plasma glucose level**

Plasma glucose in blood samples was measured using oxidase- peroxidase method [22].

##### **Measurement of plasma insulin**

Plasma insulin levels were analyzed using enzyme-linked immunosorbent assay ELISA (Dako, Carpinteria, CA) according to the manufacturer's instructions [23].

#### **HOMA-IR test**

To estimate insulin resistance, the homeostasis model assessment for insulin resistance (HOMA-IR: insulin resistance index) [24] was used, calculated as the product of fasting insulin (in  $\mu$ IU) and fasting glucose (in mmol/l) divided by 22.5. A lower index indicates greater insulin sensitivity.

#### **FFA detection**

FFA was measured in plasma samples using Free Fatty Acid Quantification Kit supplied by Abcam USA according to manufacturer guide [25].

#### **Measurement of lipid**

Plasma total cholesterol was assayed as described by Siedel *et al.* [26], while the protocols of Jacobs and Van Denmark [27] was adopted for the determination of triglycerides (TAG).

#### **Measurement of MDA**

To measure the MDA concentration, 100 mg of sciatic nerve tissue in 1 mL PBS, pH 7.0 was homogenized with micropestle in microtube. 20 % TCA was added to nerve homogenate to precipitate the protein, and centrifuged. Supernatants were collected and thiobarbituric acid (TBA) solution was added to the supernatants. After boiling for 10 minutes in water bath, the absorbance was measured. Concentration of MDA in supernatants of nerve homogenate was calculated using the standard curve [28].

#### **Measurement of SOD activity**

Superoxide dismutase (SOD) activity in nerve homogenate was measured through the inhibition of nitroblue tetrazolium (NBT) reduction by O<sub>2</sub><sup>-</sup> generated by the xanthine/xanthine oxidase system. One SOD activity unit was defined as the enzyme amount causing 50% inhibition in 1 mL reaction solution per milligram tissue protein and the result was expressed as U/mg protein [29].

#### **Measurement of TNF- $\alpha$**

TNF- $\alpha$  was measured by in nerve tissues using ELISA (quantikine R&D system USA) according to the manufacturer's instructions [30].

#### **Nerve conduction velocity measurements:**

##### **Electrophysiological Recording:**

The Sciatic nerve was mounted in a nerve chamber designed for recording of action potential from isolated nerve. It contains 15 stainless wire electrodes. The nerve was dissected free without any muscles remnants. About 2 cm of the nerve was positioned over the electrodes and embedded in paraffin oil to maximize signal amplitude and prevent drying. The proximal part of the nerve was stimulated by 2 platinum stimulating hook electrodes and the recording electrode was placed 1 cm apart from the stimulating one.

Electrophysiological measurements were performed using an AD instruments Power Lab 4/25



stimulator and Bio AMP amplifier followed by a computer assisted data analysis. Sciatic nerves were stimulated with square wave pulses of 200  $\mu$ sec duration at 1-10 volts for conduction velocities. Conduction velocity is measured by dividing the distance between the stimulating and recording electrodes by latent period, which is the time elapsed between the application of stimulus until the peak of the maximum compound action potential(CAP) [31].

#### **Statistical analysis:**

Data were analyzed using the statistical package SPSS version 15. Values were expressed as mean + standard deviation (SD). Comparisons between groups were done using analysis of variance (ANOVA) with multiple comparisons post hoc test in normally distributed quantitative variables while non para metrical Mann- Whitney test was used for non normally distributed quantitative variables. *P*-values less than 0.05 were considered as statistically significant [32].

### **3. Results**

#### **Effect of 12 weeks of HFD on body weight and BMI in rats:**

The results of this study showed a significant increase of body weight (gm) and BMI ( $\text{kg}/\text{m}^2$ ) in high fat diet group ( $p < 0.05$ ) when compared to control group (NC) after 12weeks of the start of the diet, indicating presence of obesity in HFD group (Table 3, Figures 1,2).

#### **Effect of 5 weeks of HFD (without supplementation) on body weight and BMI:**

The results reported a significant elevation in the mean values of final weight measurements (gm) and BMI( $\text{kg}/\text{m}^2$ ) in rats after 5weeks of high animal fat diet (Ob+HFD), when compared to corresponding values of normal chow group(NC).(Table 4, Figures 3,4)

#### **Effect of 5 weeks of HFD on plasma glucose, insulin, HOMA-IR in obese rats:**

Table 5 and figures 5-7 show that HFD yielded an insignificant elevation in the mean value of fasting blood glucose level (mmol/l), while there was a significant elevation in insulin level ( $\mu\text{IU}/\text{l}$ ) and HOMA-IR test after 5weeks of HFD compared to NC group. This reflects the effect of HFD on induction of insulin resistance.

#### **Effect of 5 weeks of HFD on cholesterol levels, triglycerides and free fatty acids.**

When observing levels of plasma cholesterol levels (mg/dl), triglycerides (mg/dl), and free fatty acids (mmol/l) after 5weeks of high animal fat diet (Ob+HFD) in table 6 and figures 8-10, the present results recorded a significant elevation in their plasma levels compared to NC group, denoting the effect of

obesity and HFD on dyslipidemia and elevation of plasma lipid levels.

#### **Effect of 5 weeks of HFD on oxidative stress and inflammation:**

Our results recorded a significant increase in nerve tissue malondialdehyde (MDA), and tumor necrosis factor alpha (TNF $\alpha$ ) and a significant decrease in superoxide dismutase activity (SOD) after 5weeks of high animal fat diet in obese rats compared to NC group (Table 7, Figures 11-13). This reflects impairment of antioxidant activity and the effect of HFD in obese rats on elevation oxidative stress and increased the inflammatory marker.

#### **Effect of 5 weeks of HFD on nerve conduction velocity in obese rats:**

Interestingly, the current results recorded a significant decrease in nerve conduction velocity (NCV) (m/s) after 5weeks of high animal fat diet (Ob+HFD), compared to values recorded from normal chow group of rats (NC) ( $p < 0.05$ ) (Table 8, Figure 14).

#### **Effect of changing diet composition in obese rats on different parameters: Ob+ HFD+corn oil versus Ob+HFD+ Omega 3:**

When observing the values of final body weight (gm) and BMI measurements ( $\text{kg}/\text{m}^2$ ) in rats after changing diet composition for 5W, we can observe that there was no significant variation in these values in Ob+HFD+ corn oil group or in Ob+HFD+omega 3 groups compared to values recorded in Ob+HFD group (Table 4 and Figures 3&4).

Furthermore, as shown in table (5) and figures (5-7) there was no significant variation in fasting blood glucose level in Ob+HFD+ corn oil and Ob+HFD+ Omega 3 group compared to Ob+HFD group. As regarding the mean values of fasting insulin level ( $\mu\text{IU}/\text{l}$ ) and HOMA-IR test after 5 weeks, there was no significant variation between Ob+HFD+corn oil group when compared to Ob+HFD+Omega 3, however, the plasma levels of these parameters in the Ob+HFD+ corn oil and Ob+HFD+ Omega 3 groups were significantly decreased when compared to Ob+HFD. Thus, these results reflect that changing the formula of diet from HFD only to addition of corn oil or of omega 3 to HFD improved insulin sensitivity and decreased the exposure to insulin resistance condition.

When observing levels of plasma cholesterol levels (mg/dl), triglycerides (mg/dl), and free fatty acids (mmol/l) after 5weeks diet (Ob+HFD+ corn oil or Ob+HFD+ Omega 3), table 6 and figures 8, 9 & 10 show no significant change in the mean values recorded between these 2 groups, but the mean values of these parameters in the 2groups were significantly decreased when compared to mean values recorded in

Ob+HFD group. This indicates that the corn oil or omega3 protected against dyslipidemia.

When nerve tissue malondialdehyde level (MDA), superoxide dismutase activity (SOD) and tumor necrosis factor alpha level(TNF $\alpha$ ) were estimated after 5weeks of high corn oil diet (Ob+HFD+ corn oil), or high fat diet supplemented with omega 3 (Ob+HFD+Omega 3) in male rats, it can be observed that there was no significant variation in mean values of MDA, SOD activity or TNF $\alpha$  in Ob+HFD+ corn oil group compared to Ob+HFD+ Omega 3 group, but the 2 groups showed significantly decreased tissue malondialdehyde and (MDA) and tumor necrosis factor alpha (TNF $\alpha$ ) levels and significantly increased superoxide dismutase activity (SOD) when compared to Ob+HFD (Table 7, Figures 11-13).

Regarding NCV(m/s) values, both in Ob+HFD+ corn oil and Ob+ HFD+Omega 3 groups, there was a significant increase compared to Ob+HFD and their values in Ob+HFD+ corn oil

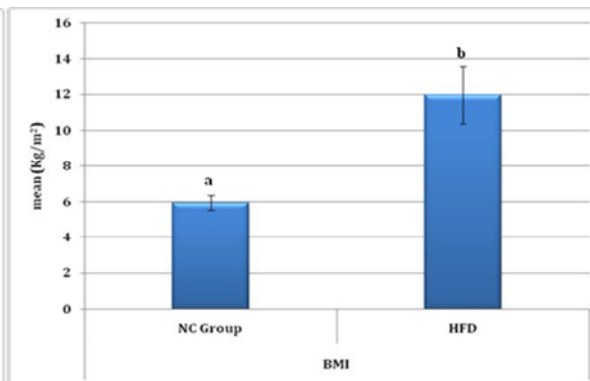
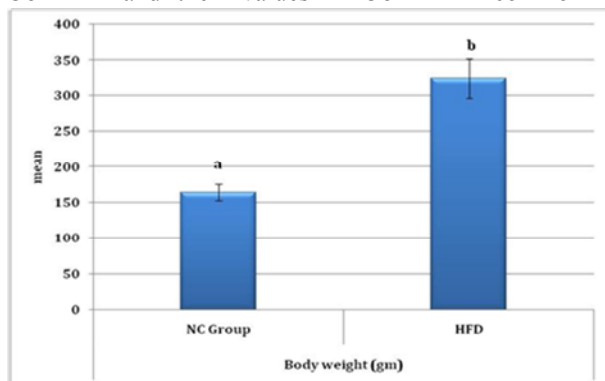
group showed no significant variation as compared to control group. In contrast in Ob+ HFD+Omega 3 group, there was a significant decrease in values of this group as compared to the control group and Ob+HFD+ corn oil (Table 8, Figure 14).

**Table 3:** Body weight measurements (gm) and body mass index (Kg/m<sup>2</sup>) in rats after 12weeks of normal chow (NC) (n=8), high animal fat diet (HFD)(n=24), in male rats.

	NC Group	HFD group
<b>Body weight (gm)</b> Mean $\pm$ SD	163.88 $\pm$ 11.52 <sup>a</sup>	324.25 $\pm$ 28.07 <sup>b</sup>
<b>BMI (Kg/m<sup>2</sup>)</b> Mean $\pm$ SD	5.93 $\pm$ 0.40 <sup>a</sup>	11.69 $\pm$ 1.09 <sup>b</sup>

Results with different letters in the same raw are significant ( $p < 0.05$ )

Results with the same letter in the same raw are insignificant ( $p > 0.05$ ).



**Figure 1: Body weight measurements (gm) and figure 2: body mass index in rats after 12weeks of normal chow(NC) (n=8), high animal fat diet (HFD)(n=24), in male rats.**

Results with different letters are significant ( $p < 0.05$ )

Results with the same letter are insignificant ( $p > 0.05$ ).

Results with the same letter in the same raw are insignificant ( $p > 0.05$ ).

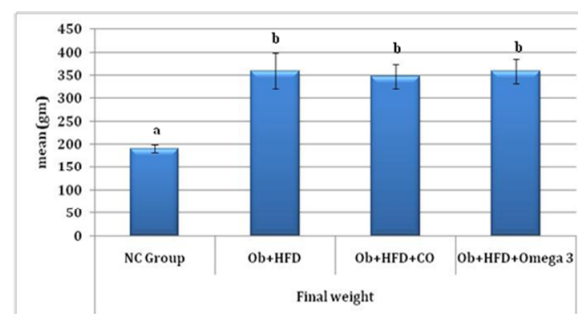
**Table 4:**Final body weight measurements (gm) and body mass index(Kg/m<sup>2</sup>) in rats after 5weeks of normal chow(NC), high animal fat diet (Ob+HFD), high corn oil diet (Ob+HFD+corn oil), or high fat diet supplemented with omega 3 (Ob+HFD+Omega 3) in male rats.

	NC group	Ob +HFD	Ob+ corn oil	Ob+HFD +Omega 3
<b>Final weight (gm)</b>	189.50 $\pm$ 8.50 <sup>a</sup>	359.38 $\pm$ 38.53 <sup>b</sup>	347.25 $\pm$ 25.76 <sup>b</sup>	358.13 $\pm$ 26.16 <sup>b</sup>
<b>BMI (kg/m<sup>2</sup>)</b>	5.93 $\pm$ 0.40 <sup>a</sup>	11.96 $\pm$ 1.62 <sup>b</sup>	11.70 $\pm$ 0.55 <sup>b</sup>	11.90 $\pm$ 0.43 <sup>b</sup>

(n=8)

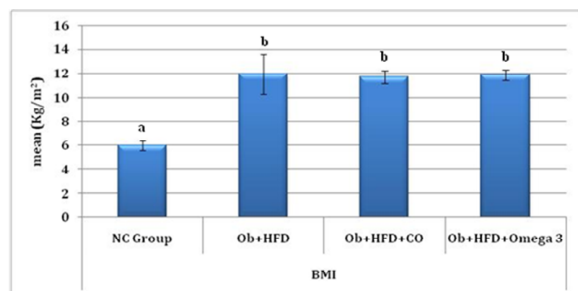
Results are mean  $\pm$  SD.

Results with different letters in the same raw are significant ( $p < 0.05$ )



**Figure 3:** Final body weight measurements (gm) in rats after 5weeks of normal chow(NC), high animal fat diet (Ob+HFD), high corn oil diet (Ob+HFD+corn oil), or high fat diet supplemented with omega 3 (HFD+Omega 3) in male rats.

(n=8) -Results with different letters are significant ( $p < 0.05$ ).-Results with the same letter are insignificant ( $p > 0.05$ ).



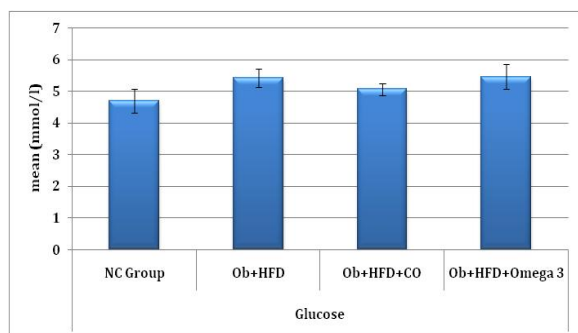
**Figure 4:** Body mass index (kg/m<sup>2</sup>) in rats after 5weeks of normal chow(NC), high animal fat diet (Ob+HFD), high corn oil diet (Ob+HFD+corn oil), or high fat diet supplemented with omega 3 (HFD+Omega 3) in male rats. n=8

Results with different letters are significant ( $p < 0.05$ )  
Results with the same letter are insignificant ( $p > 0.05$ ).

**Table 5:** Fasting plasma glucose level (mmol/l), insulin level(μIU/l) and HOMA-IR test after 5weeks of normal chow(NC), high animal fat diet (Ob+HFD), high corn oil diet rich in polyunsaturated fatty acids( Ob+HFD+corn oil), or high fat diet supplemented with omega 3 (HFD+Omega 3) in male rats.

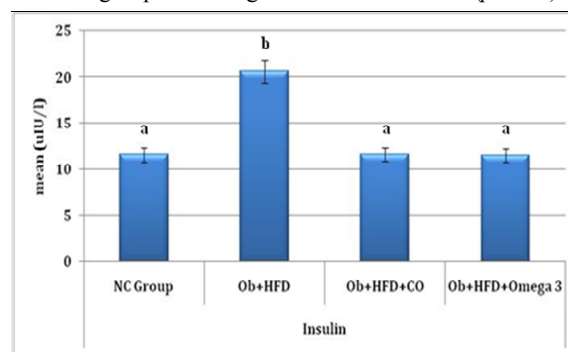
	NC group	Ob+HFD	Ob+HFD +corn oil	Ob+HFD + Omega 3
Glucose mmol/l	4.69 ± 0.37	5.41 ± 0.30	5.05 ± 0.18	5.45 ± 0.39
Insulin μIU/l	11.64± 0.78 <sup>a</sup>	20.59 ± 1.20 <sup>b</sup>	11.68 ± 0.74 <sup>a</sup>	11.55 ± 0.76 <sup>a</sup>
HOMA-IR	2.43 ± 0.26 <sup>a</sup>	4.95 ± 0.40 <sup>b</sup>	2.63 ± 0.23 <sup>a</sup>	2.80 ± 0.31 <sup>a</sup>

(n=8)  
Results are mean ± SD.  
Results with different letters in the same raw are significant ( $p < 0.05$ )  
Results with the same letter in the same raw are insignificant ( $p > 0.05$ ).



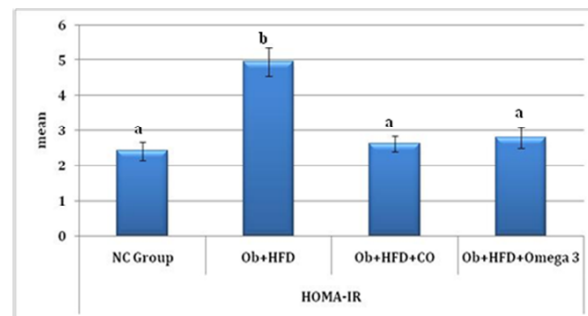
**Figure 5:** Fasting plasma glucose level (mmol/l) after 5weeks of normal chow(NC), high animal fat diet (Ob+HFD), high corn oil diet rich in polyunsaturated fatty acids ( Ob+HFD+corn oil), or high fat diet supplemented

with omega 3 (HFD+Omega 3) in male rats. Results in the different groups are insignificant to each other ( $p > 0.05$ ).



**Figure 6:** Insulin level(μIU/l) after 5weeks of normal chow(NC), high animal fat diet (Ob+HFD), high corn oil diet rich in polyunsaturated fatty acids( Ob+HFD+corn oil), or high fat diet supplemented with omega 3 (HFD+Omega 3) in male rats.

Results with different letters are significant ( $p < 0.05$ )  
Results with the same letter are insignificant ( $p > 0.05$ ).



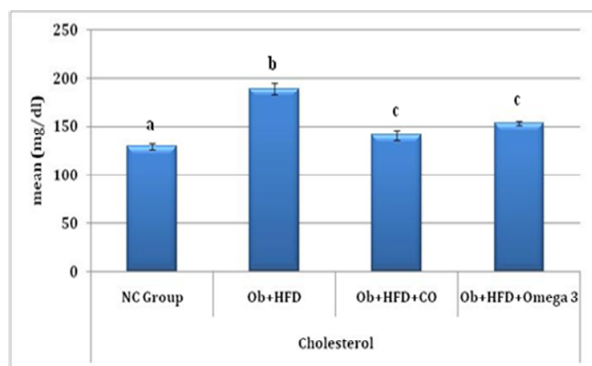
**Figure 7:** HOMA-IR test after 5weeks of normal chow(NC), high animal fat diet (Ob+HFD), high corn oil diet rich in polyunsaturated fatty acids( Ob+HFD+corn oil), or high fat diet supplemented with omega 3 (HFD+Omega 3) in male rats.

Results with different letters are significant ( $p < 0.05$ )  
Results with the same letter are insignificant ( $p > 0.05$ ).

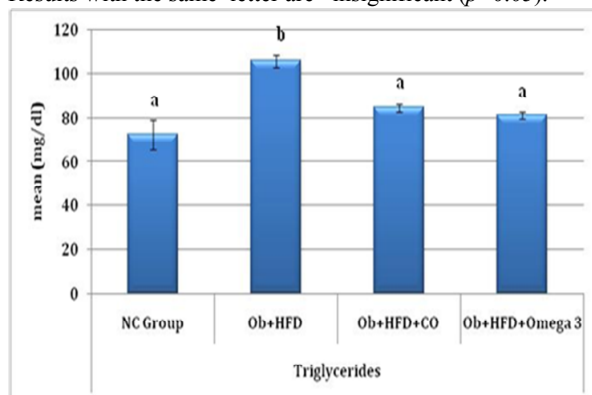
**Table 6:** Plasma cholesterol levels (mg/dl), triglycerides (mg/dl), and free fatty acids (mmol/l) after 5weeks of normal chow(NC), high animal fat diet (Ob+HFD), high corn oil diet (Ob+HFD+corn oil), or high fat diet supplemented with omega 3 (Ob+HFD+Omega 3) in male rats.

	NC group	Ob+HFD	Ob+HFD +corn oil	Ob+HFD + Omega 3
Cholesterol mg/dl	128.79± 2.86 <sup>a</sup>	188.44 ± 6.3439 <sup>b</sup>	140.86 ± 5.36 <sup>c</sup>	153.11 ± 2.00 <sup>c</sup>
Triglycerides mg/dl	72.43 ± 6.92 <sup>a</sup>	105.75 ± 2.80 <sup>b</sup>	84.53 ± 1.84 <sup>a</sup>	81.25 ± 1.64 <sup>a</sup>
FFA mmol/l	0.17 ± 0.04 <sup>a</sup>	0.52 ± 0.04 <sup>b</sup>	0.24 ± 0.02 <sup>a</sup>	0.27 ± 0.02 <sup>a</sup>

(n=8)  
Results are mean ± SD.  
Results with different letters in the same are significant ( $p < 0.05$ )  
Results with the same letter in the same raw are insignificant ( $p > 0.05$ ).

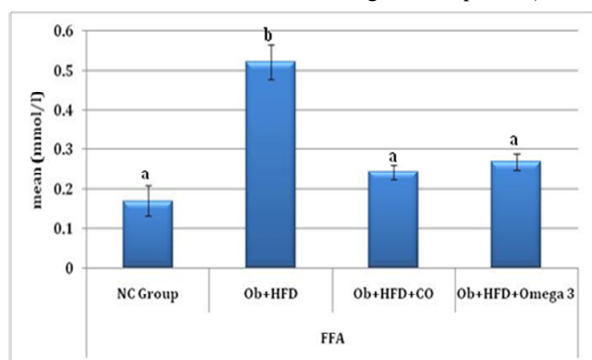


**Figure 8:** Plasma cholesterol levels (mg/dl) after 5weeks of normal chow(NC), high animal fat diet (Ob+HFD), high corn oil diet (Ob+HFD+corn oil), or high fat diet supplemented with omega 3 (Ob+HFD+Omega 3) in male rats. Results with different letters are significant ( $p < 0.05$ ) Results with the same letter are insignificant ( $p > 0.05$ ).



**Figure 9:** Plasma triglycerides (mg/dl) after 5weeks of normal chow (NC), high animal fat diet (Ob+HFD), high corn oil diet (Ob+HFD+corn oil), or high fat diet supplemented with omega 3 (Ob+HFD+Omega 3) in male rats.

Results with different letters are significant ( $p < 0.05$ ). Results with the same letter are insignificant ( $p > 0.05$ ).



**Figure 10:** Plasma free fatty acids (mmol/l) after 5weeks of normal chow(NC), high animal fat diet (Ob+HFD), high corn oil diet (Ob+HFD+corn oil), or high fat diet supplemented with omega 3 (Ob+HFD+Omega 3) in male rats.

Results with different letters are significant ( $p < 0.05$ ). Results with the same letter are insignificant ( $p > 0.05$ ).

**Table 7:** Tissue malondialdehyde level (MDA), superoxide dismutase activity (SOD) and tumor necrosis factor alpha level (TNF $\alpha$ ) after 5weeks of normal chow(NC), high animal fat diet (Ob+HFD), high corn oil diet (Ob+HFD+corn oil), or high fat diet supplemented with omega 3 (HFD+Omega 3) in male rats.

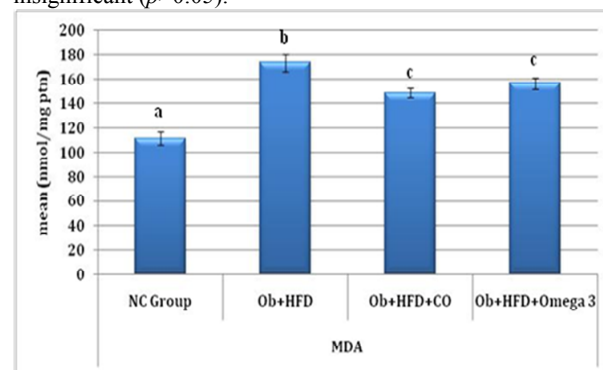
	NC group	Ob+HFD	Ob+HFD +corn oil	Ob+HFD + Omega 3
MDA nmol/mg ptn	111.36 $\pm$ 5.51 <sup>a</sup>	173.10 $\pm$ 7.07 <sup>b</sup>	148.51 $\pm$ 3.93 <sup>c</sup>	156.30 $\pm$ 4.84 <sup>c</sup>
SOD activity U/mg ptn	2.03 $\pm$ 0.17 <sup>a</sup>	0.45 $\pm$ 0.02 <sup>b</sup>	1.26 $\pm$ 0.15 <sup>c</sup>	1.60 $\pm$ 0.26 <sup>c</sup>
TNF $\alpha$ pg/ml	112.15 $\pm$ 2.07 <sup>a</sup>	234.89 $\pm$ 4.78 <sup>b</sup>	187.79 $\pm$ 4.62 <sup>c</sup>	207.23 $\pm$ 5.03 <sup>c</sup>

(n=8)

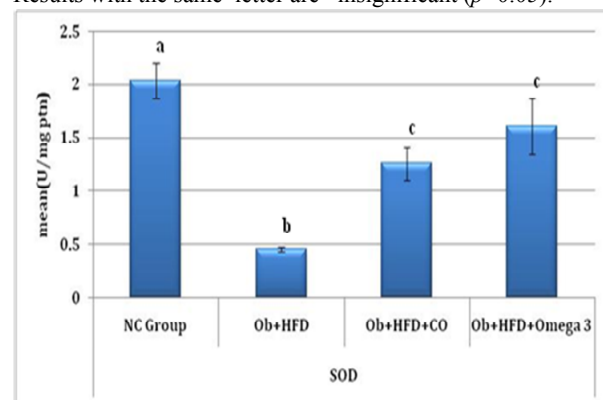
Results are mean  $\pm$  SD.

Results with different letters in the same raw are significant ( $p < 0.05$ )

Results with the same letter in the same raw are insignificant ( $p > 0.05$ ).

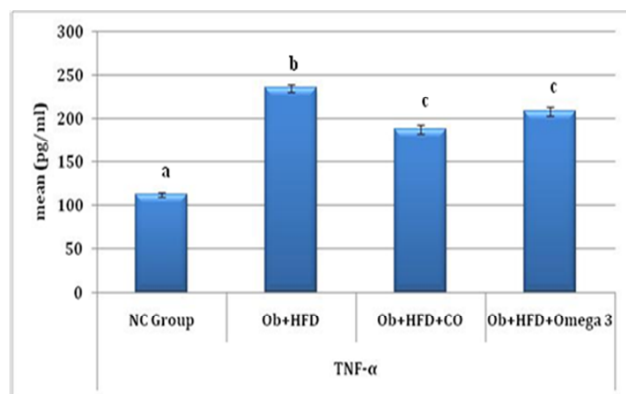


**Figure 11:** Tissue malondialdehyde (MDA) after 5weeks of normal chow(NC), high animal fat diet (Ob+HFD), high corn oil diet (Ob+HFD+corn oil), or high fat diet supplemented with omega 3 (HFD+Omega 3) in male rats. Results with different letters are significant ( $p < 0.05$ ). Results with the same letter are insignificant ( $p > 0.05$ ).



**Figure 12:** Tissue superoxide dismutase activity (SOD) after 5weeks of normal chow(NC), high animal fat diet (Ob+HFD), high corn oil diet (Ob+HFD+corn oil), or high fat diet supplemented with omega 3 (HFD+Omega 3) in male rats.

Results with different letters are significant ( $p < 0.05$ ). Results with the same letter are insignificant ( $p > 0.05$ ).



**Figure 13:** Tissue tumor necrosis factor alpha (TNF $\alpha$ ) after 5weeks of normal chow(NC), high animal fat diet (Ob+HFD), high corn oil diet (Ob+HFD+corn oil), or high fat diet supplemented with omega 3 (HFD+Omega 3) in male rats.

Results with different letters are significant ( $p < 0.05$ ). Results with the same letters are insignificant ( $p > 0.05$ ).

**Table 8:** Nerve conduction velocity (NCV) (m/s) after 5weeks of normal chow(NC), high animal fat diet (Ob+HFD), high corn oil diet (Ob+corn oil), or high fat diet supplemented with omega 3 (HFD+Omega 3) in male rats.

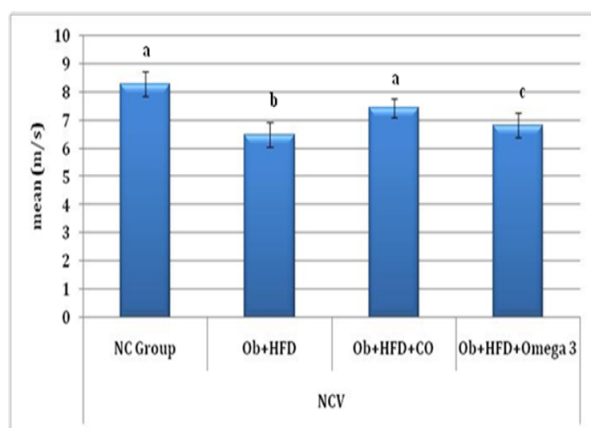
	NC group	Ob +HFD	Ob+HFD +corn oil	Ob+HFD + Omega 3
NCV m/s	8.28 $\pm$ 0.44 <sup>a</sup>	6.49 $\pm$ 0.43 <sup>b</sup>	7.85 $\pm$ 0.33 <sup>a</sup>	7.22 $\pm$ 0.43 <sup>c</sup>

(n=8)

Results are mean  $\pm$  SD.

Results with different letters in the same raw are significant ( $p < 0.05$ )

Results with the same letter in the same raw are insignificant ( $p > 0.05$ ).



**Figure 14:** Nerve conduction velocity (NCV) (m/s) after 5weeks of normal chow(NC), high animal fat diet (Ob+HFD), high corn oil diet (Ob+corn oil), or high fat diet supplemented with omega 3 (HFD+Omega 3) in male rats.

Results with different letters are significant ( $p < 0.05$ )

Results with the same letter are insignificant ( $p > 0.05$ ).

#### 4. Discussion:

Obesity is a strong risk factor for developing dyslipidemia [33,34], diabetes mellitus [35], fatty liver [36], cardiovascular (CV) diseases such as heart failure (HF) and coronary heart disease (CHD) [37].

Feeding of (HFD) to rats was proved to be a useful model of putative effects of dietary fat in humans [38]. In the present study, obesity was induced in rats by using a high fat diet. Obesity was induced in 12 weeks. The weight of rats fed HFD was significantly more than that of rats fed the normal diet. Rat models are therefore useful tools for inducing obesity as they will readily gain weight when fed high-fat diets [39]. Many workers were able to induce obesity in rats using different formulas of high fat diets [40-42].

An evidence for insulin resistance was recorded in the present study. Although fasting blood glucose levels were not significantly different between NC rats and Ob+HFD fed rats, insulin levels were significantly increased in Ob+HFD fed rats compared to NC rats and HOMA-IR test showed a significant increase in Ob+ HFD fed rats compared to NC rats. In agreement with our results, Oltman *et al.*[3] reported that obese Zucker rats are insulin resistant. Also Davidson *et al.* [43] reported that the obese Zucker HFD fed rats were not hyperglycemic; however, they were insulin resistant.

In contrast, Watcho *et al.* [8] and Obrosova *et al.* [44] reported that a 16-week HFD feeding resulted in a modest (14.5%) increase in non-fasting blood glucose concentrations compared with the mice fed NC which they described as being consistent with increased serum insulin concentrations as well as insulin resistance and impaired glucose utilization previously described in this model[45]. Moreover, Ishii *et al.* [46] reported that after 16 weeks of age, the group on a standard diet showed an increase in serum glucose levels and a decrease in serum insulin levels compared with high fat diet fed rats. Unexpectedly, in the group on the high-fat diet, they observed a suppressed of the progression of hyperglycemia and hypoinsulinemia. This might be explained in part by different animal species, variable duration of diet or by measuring non fasting blood glucose level.

We can see from these results that HFD fed obese rats developed insulin resistance, but did not developed diabetes or hyperglycemia.

It was also recorded from the results of this study that HFD in obese rats resulted in dyslipidemic changes as illustrated by increasing serum levels of triglycerides, total cholesterol, free fatty acids as compared to control; a finding in accordance with that of Woo *et al.* [47], and Kamal and Mohamed [48].

Dyslipidemic changes occurs in obesity may be due to the increased triglycerides content of the liver due to increased influx of excess non esterified fatty acids (NEFAs) into the liver[49]. Lipid alterations affect the structure and function of the nerve membrane and have been considered as contributory factors to oxidative stress in obesity [50].

In the present study, it was found that nerve MDA level was significantly elevated with a significant decrease in the enzyme superoxide dismutase activity in HFD fed obese rats compared to NC rats and this was an indication for increased oxidative stress in these obese rats. Increased production of reactive oxygen species as well as reduced antioxidant defense mechanisms have been suggested to play a role in both humans and animal obesity induced pathology [51,52].

Interestingly, oxidative stress, the key metabolic abnormalities previously thought to be caused primarily by high glucose and shown to contribute to diabetic neuropathy, clearly manifest in this Ob+HFD model of pre-diabetic neuropathy characterized by insulin resistance in the absence of overt diabetes or hyperglycemia.

In this study, our obese rats also developed nerve disorder, demonstrated as NCV slowing. The finding that rats fed a high fat diet develop indices of neuropathy is consistent with studies of obese Zucker rats [3, 53], and also with clinical studies in which pre-diabetes and impaired glucose tolerance have been associated with an early-onset neuropathy [54, 55]. It was previously suggested that impaired glucose tolerance can directly cause nerve injury [56], however, it appears that NCV slowing is simply a covariant with other factors related to obesity.

This study shows that velocity of sciatic nerve conduction in obese rats could depend on dietary fat modification. The addition of omega 3 to high animal fat diet or consumption of corn oil rich in omega 6&9 PUFA in addition to animal fat was associated with increased sciatic nerve conduction velocity in obese rats, whereas high animal fat diet in obese rats caused a significant slowing of sciatic nerve conduction velocity. In addition, we found that omega 6&9 PUFA supplemented food (corn oil) induced a significant improvement of nerve conduction velocity compared to the enriching food with omega 3. These data show that omega 3 enrichment or corn oil could be associated with improved nerve conduction velocity in obese rats.

The present study provides evidence of the therapeutic efficacy of omega 6&9 PUFA and omega 3 on NCV deficits, in the model of neuropathy associated with obesity. It should be noticed that the improvement in NCV was not associated with weight reduction. As seen from the

results of the present study, there is no significant change in final body weight or BMI between the obese groups fed HFD with animal fat, corn oil or supplemented with omega 3 fatty acids.

Some previous studies suggested an association between insulin resistance, compensatory hyperinsulinemia, and peripheral neuropathy in human. Also, higher insulin resistance was independently associated with the presence of cardiac autonomic neuropathy (CAN) in Korean type 2 diabetes mellitus (T2DM) patients [57].

In the present study it was shown that either omega 3 or corn oil supplementation was associated with improved insulin sensitivity and decreased blood insulin level and this may play a role in improving nerve conduction, however the exact mechanism for this relation is not clear and needs further investigations.

One study provides evidence that insulin receptor substrate (IRS) proteins are expressed in the dorsal root ganglia (DRG) and could play an important role in the ability of insulin to support peripheral neurons. Elevated serine phosphorylation of IRS proteins reported in their study to be a major contributing mechanism underlying the effect of insulin resistance on neurons [58].

Insulin resistance is an important risk factor for endothelial dysfunction, and impairment of vascular function of epineurial arterioles precedes nerve dysfunction in obese normoglycemia Zucker rats [59]. It has been shown that improving insulin sensitivity improves vascular resistance in obese Zucker rats [60].

We can see from the results of the present study that dyslipidemia may be a contributing factor to reductions in peripheral nerve conduction velocity. This dyslipidemia was shown to be mostly corrected by dietary supplements and this correction appears to play a role in improvement of nerve conduction velocity, may be in part by a normalization of fatty acid composition of nerve membrane and eicosanoid synthesis, which is depressed in neuropathy and/or by a direct effect on incorporation of these fatty acids into the plasma membranes [61]. By changing membrane properties, omega 6&9 or omega 3 PUFA can modify the activity of transmembrane enzymes, such as Na,K- Atpase, which is implicated in the propagation of nerve impulses[62].

Our findings are consistent with studies showing that high dietary intake of fatty acids prevents the development and clinical progression of nerve conduction deficits in diabetic animals as well as in the general human population [63,11]. In diabetic rats, the administration of linoleic acid, an n-6 fatty acid, improved sciatic NCV [11]. In patients with generalized peroxisomal disorders, congenital

diseases with impaired myelinogenesis, the administration of the n-3 fatty acids, DHA, significantly improved myelin formation alleviating the symptoms in these patients [64].

PUFA are the major structural components of the neuronal membrane phospholipids [65] and therefore, their structural and chemical characteristics influence membrane functions, such as the activity of membrane bound proteins, signal transduction and also neurotransmission [66-68]. It was also reported that supplementation with sunflower oil, which contains high quantity of linoleic acid, restored NCV in diabetic rats, and this effect was accompanied by a modification of phospholipid fatty acid composition in nerve membranes [10].

In particular, the electrophysiologic effect of the omega-3 fatty acids seems to be the result of specific modulation of ion currents, particularly of the voltage-dependent sodium current and of the L-type calcium currents across sarcolemmal phospholipids membranes [68].

Mammals synthesize the long chain PUFA from linoleic acid [18:2(n-6)] and  $\alpha$ -linolenic acid [18:3(n-3)], which are the 2 precursors of (n-6) and (n-3) fatty acids families provided by the diet. Specific enzymes, desaturases and elongases, are involved in this pathway, but the conversion of precursors to long chain PUFA is generally low in humans. Consequently, the decrease in bioavailability of PUFA, affects the fatty acid composition of membrane phospholipids (PL) with repercussions on membrane protein functionality [69], eicosanoid production [70, 71], and peroxisome proliferator-activated receptor (PPAR) regulation [72, 73].

It was suggested that the rate-limiting nature of  $\omega$ -6-desaturation contributes to the development of neuropathy. Bypassing the rate-limiting step by using gamma-linolenic acid (GLA) may have desirable effects and anti-inflammatory effects [74]. Because essential fatty acids (EFAs) and their metabolites are exceptionally important in both the structure and function of nerves [75], it seemed possible that neuropathy might be particularly responsive to PUFA supplementation.

An important observation in the results of this study is that omega-6 fatty acids, supplied by corn oil, appear to have a beneficial effect on peripheral nerve function than omega-3 fatty acids, requires consideration. In fact, omega-6 PUFAs are generally more highly represented in the nerve membrane than omega-3 fatty acids and have major effects of excess than the n-3 fatty acids [76].

The beneficial effects of omega 6&9 or omega 3PUFA may at least partially be related to inhibition of oxidative stress in peripheral nerve as evidenced in the present results by improving the antioxidant

enzyme superoxide dismutase activity and decreasing oxidative stress marker MDA.

Oxidative stress is closely linked to upregulation of 12/15-lipoxygenase (12/15LO), an enzyme converting arachidonic acid to 12-Hydroxyeicosatetraenoic acid (12(S)-HETE), 15(S)-HETE, and a number of derivatives of these acids. These lipid-like compounds undergo spontaneous lipid peroxidation, which leads to induction of oxidative nitrosative stress, activation of mitogen-activated protein kinases (MAPKs), and proinflammatory response [77, 78]. MAPK activation has been demonstrated to play an important role in peripheral diabetic neuropathy [79, 80].

It was demonstrated that reducing oxidative stress in epineural vessels improved vascular relaxation to acetylcholine as well as NCV [52, 81-83]. The increase in superoxide in the aorta of high fat fed rats is likely due to increased NAD(P)H oxidase activity and/or expression, which has been linked to increased activity of angiotensin in obesity [84].

Finally, the results of the present study show that diet supplemented with omega 3 or PUFA rich in omega 6&9 fatty acids induce an anti-inflammatory effect as indicated by decreased TNF alpha content in the sciatic nerve of the obese rats.

Evidence for the importance of low grade inflammation in diabetic neuropathy is also emerging from both experimental and clinical studies [85,86].

Our results are in agreement with Ferrucci *et al.* [87] and Kapoor and Huang [88] who reported from their studies that n-3 PUFAs and the gamma linolenic acid (GLA), an n-6 fatty acid, have been shown to have significant anti-inflammatory properties. PUFAs inhibit the production of proinflammatory cytokines, i.e., IL-1 $\beta$ , IL6 and tumor necrosis factor-alpha by activating transcription factors, such as the peroxisome proliferator-activated receptors and nuclear factor kB [89]. As inflammation is one of the main pathophysiologic processes involved in peripheral polyneuropathy, it could be extremely relevant in progression of axonal damage [90].

Studies in normal volunteers indicate that omega-3 fatty acid supplementation reduced the ability of monocytes to produce IL-1 $\beta$  upon stimulation with endotoxin. The effect was most pronounced 10 weeks after stopping the supplementation and suggests prolonged incorporation of omega-3 fatty acids into a pool of circulating monocytes [91]. The capacity of the monocytes from these donors to synthesize IL-1 $\beta$  returned to the pre-supplement level 20 weeks after ending supplementation. Similar results were observed for IL-1 $\alpha$  and TNF [92].

Previous studies suggested that in patients affected by peripheral neuropathy, a supplementation with PUFA may positively influence the axonal degeneration of the nerve [10].

### Conclusion

The results of this study have important clinical and speculative implications. Based on our findings, we suggest that corn oil or omega 3 supplementation may be effective in treatment of obesity induced neuropathy. The mechanism of their effects is multifactorial including improving insulin sensitivity, correction of dyslipidemia which could reflect on fatty acid composition of the nerve membrane structure and function, reducing oxidative stress and an anti-inflammatory effect. This possibility should be carefully considered and examined in future trials of essential fatty acid supplementation.

### Acknowledgment

The authors thank Prof Dr Laila Rashed (MD biochemistry) for great assistance in biochemical measurements

### Corresponding author

#### Samah Elattar

Department of Physiology, Faculty of Medicine, Cairo University, Cairo, Egypt  
[omarattar1993@yahoo.com](mailto:omarattar1993@yahoo.com)

### References:

- Haslam DW, James WP. Obesity. *Lancet*. 2005;366 (9492):1197-209.
- Díaz M E, Jiménez S, García RG, Bonet M, Wong I. Overweight, obesity, central adiposity and associated chronic diseases in cuban adults. *MEDICC Review*. 1 2009; 11 (4):23-8.
- Oltman CL, Coppey LJ, Gellert JS, Davidson EP, Lund DD, Yorek MA. Progression of vascular and neural dysfunction in sciatic nerves of Zucker diabetic fatty and Zucker rats. *Am J Physiol Endocrinol Metab*. 2005;289(1):E113-22.
- Singleton JR, Smith AG. Neuropathy associated with prediabetes: what is new in 2007?. *Current Diabetes Reports*. 2007; 7: 420-4.
- Vincent AM, Hayes JM, McLean LL, Vivekanandan-Giri A, Pennathur S, Feldman EL. Dyslipidemia-induced neuropathy in mice: the role of oxLDL/LOX-1. *Diabetes*. 2009; 58(10):376-85.
- Veves A, Backonja M, Malik RA. Painful diabetic neuropathy: epidemiology, natural history, early diagnosis, and treatment options. *Pain Med*. 2008 ;9(6):660-74.
- Von Diemen V, Trindade EN, Trindade MR. Experimental model to induce obesity in rats. *Acta Cir Bras*. 2006;21(6):425-9.
- Watcho P, Stavniichuk R, Ribnický DM, Raskin I, Obrosova IG. High-Fat Diet-Induced Neuropathy of Prediabetes and Obesity: Effect of PMI-5011, an Ethanolic Extract of *Artemisia dracunculus* L. *Mediators of Inflammation*. 2010;2010 (268547):1-10.
- Lupachyk S, Watcho P, Hasanova N, Julius U, Obrosova IG. Triglyceride, non esterified fatty acids, and prediabetic neuropathy: role for oxidative-nitrosative stress. *Free Radic Biol Med*. 2012;52(8):1255-63.
- Lauretani F, Bandinelli S, Benedetta B, Cherubini A, Iorio AD, Blè, A, Giacomini V, Corsi AM, Guralnik JM, Ferrucci L. Omega-6 and omega-3 fatty acids predict accelerated decline of peripheral nerve function in older persons. *Eur J Neurol*. 2007 ;4(7): 801-8.
- Head RJ, McLennan PL, Raederstorff D, Muggli R, Burnard SL, McMurchie EJ. Prevention of nerve conduction deficit in diabetic rats by polyunsaturated fatty acids. *The American journal of Clinical Nutrition*. 2000;71:386S-392S.
- Cameron, N.E. Metabolic and vascular factors in the pathogenesis of diabetic neuropathy. *Diabetes*. 1997;46 (12): 531-7.
- Jarrahi, M., Effect of diet Containing fish oil on nerve Conduction velocity of diabetic albino rats. *Fall, 1999;1.1: 1.1*.
- Weisinger HS, Armitage JA, Sinclair AJ, Vingrys AJ, Burns PL, Weisinger RS. Perinatal omega-3 fatty acid deficiency affects blood pressure later in life. *Nat Med*. 2001;7:258-9.
- Marchioli R, Levantesi G, Macchia A. Antiarrhythmic mechanisms of n-3 PUFA and the results of the GISSI-Prevenzione Trial. *J Membr Biol*. 2005;206:117.
- Murray NR, Weems C, Chen L. Protein kinase C beta II and TGF beta RII in omega-3 fatty acid-mediated inhibition of colon carcinogenesis. *J Cell Biol*. 2002;157:915-920.
- Lee KY, Ahn HC, Kim C, Kim SH, Kim DK, Park HS. Pancreatic Exocrine Response to Long-Term High-Fat Diets in Rats. *JOP. J Pancreas (Online)* 2006; 7(4):397-404.
- Kuda O, Jelenik T, Jilkova Z, Flachs P, Rossmeisl M. n-3 Fatty acids and rosiglitazone improve insulin sensitivity through additive stimulatory effects on muscle glycogen synthesis in mice fed a high-fat diet. *Diabetologia*. 2009;52:951.
- Giacometti J, Tomljanovic AB, Milin C, Cuk M, Stasic BR. Olive and corn oil enriched diets changed the phospholipid fatty acid composition in mice liver after one-thirds hepatectomy. *Food and Nutrition Sciences*, 2012, 3, 240-248
- Bas O, Songur A, Sahin O, Mollaoglu H. The protective effect of fish n-3 fatty acids on cerebral



- ischemia in rat hippocampus. *Neurochem Int.* 2007;50:548-54.
21. Jeyakumar SM, Vajreswari A, Giridharan NV: Chronic dietary vitamin A supplementation regulates obesity in an obese mutant WNIN/Ob rat model. *Obesity* 2006, 14:52-9.
  22. Trinder L. Determination of blood glucose using an oxidase peroxidase system with a non-carcinogenic chromagen. *Ann. Clin. Biochem.* 1969; 1: 24-9.
  23. Delams H. G. Biochemical analysis of human and animal serum for monoclonal antibodies using ELISA. *Biochem.* 1986; 14, 214-31.
  24. Mathews DR., Hosker JP, Rudenski AS, Naylor BA, Treacher DF, Turner RC. Homeostasis model assessment: insulin resistance and  $\beta$ -cell function from fasting plasma glucose and insulin concentrations in man. *Diabetologia.* 1985;28: 412-9.
  25. Erridge C & Samani NJ. Saturated fatty acids do not directly stimulate Toll-like receptor signaling. *Arterioscler Thromb Vasc Biol.* 2009;29: 1944-9.
  26. Siedel J, Hagele EO, Ziegenhorn J, Wahlefeld AW. Reagent for the enzymatic determination of serum total cholesterol with improved lipolytic efficiency. *Clinical Chemistry.* 1983;29(6):1075-1080.
  27. Jacobs NJ, VanDenmark PJ. Enzymatic determination of serum triglyceride.ch. *Biochemistry and Biophysics.* 1960;88:250-255.
  28. Wills ED. Evaluation of lipid peroxidation in lipids and biological membranes. In: Snell K, Mullock B, eds. *Biochemical toxicology: A practical approach.* London: Oxford;1987.
  29. Misra HP, Fridovich I: the role of superoxide in the autooxidation of epinephrine and a simple assay for superoxide dismutase. *J Biol Chem.* 1972;247:3170-5.
  30. Maskos K, Fernandez-Catalan C, Huber R, Bourenkov GP, Bartunik H, Ellestad GA, *et al.* Crystal structure of the catalytic domain of human tumor necrosis factor- $\alpha$ -converting enzyme. *Proc. Natl. Acad. Sci. U.S.A.* 1998;95: 3408-12.
  31. Leal-Cardoso JH, Matos-Brito BG, Lopes-Junior JEG, Viana-Cardoso KV, Sampaio-Freitas AB, Brasil RO, Coelho-de-Souza AN, Albuquerque AAC. Effects of estragole on the compound action potential of the rat sciatic nerve. *Brazilian Journal of Medical and Biological Research.* 2004; 37(8), 1193-8.
  32. Chan YH. *Biostatistics 102: Quantitative Data – Parametric & Non-parametric Tests.* Singapore Med J. 2003;44(8): 391-6.
  33. Montani JP, Carroll JF, Dwyer TM, Antic V, Yang Z, Dulloo AG. Ectopic fat storage in heart, blood vessels and kidneys in the pathogenesis of cardiovascular diseases. *Int J Obes.* 2004;28:S58-65.
  34. Fried M, Hainer V, Basdevant A, Buchwald H, Dietel M, Finer N, Greve JW, Horber F, Mathus-Vliegen E, Scopinaro N, Steffen R, Weiner R, Widhalm K. Interdisciplinary European guidelines on surgery for severe obesity. *Rozhl Chir.* 2008;87:468.
  35. Pagotto U, Vanuzzo D, Vicennati V, Pasquali RG. Pharmacological therapy of obesity. *G Ital Cardiol (Rome)* 2008;9(4 Suppl1):835-935.
  36. Marović D. Elevated body mass index fatty liver. *Srp Arh Celok Lek.* 2008;136:122-125.
  37. Lavie CJ, Artham SM, Milani RV, Ventura HO. The obesity paradox: impact of obesity on the prevalence prognosis of cardiovascular diseases. *Postgrad Med.* 2008;120:34.
  38. Lopez IP, Marti A, Milagro FI, Zulet Md Mde L, Moreno-Aliaga MJ, Martinez A, De Miguel C. DNA microarray analysis of genes differentially expressed in diet-induced (cafeteria) obese rats. *Obes Res.* 2003;11:188.
  39. Diemen V, Trindade N, Trindade R. Experimental model to induce obesity in rats. *Acta Cir Bras.* 2006;21:425.
  40. Kim JH, Hahm DH, Yang DC, Kim JH, Lee HJ, Shim I. Effect of crude saponin of Korean red ginseng on high-fat diet-induced obesity in the rat. *J Pharmacol Sci.* 2005;97:124.
  41. Diniz YS, Faine LA, Galhardi CM, Rodrigues HG, Ebaid GX, Burneiko RC, Cicogna AC, Novelli EL. Monosodium glutamate in standard and high-fiber diets. Metabolic syndrome and oxidative stress in rats. *Nutrition.* 2005;21:749.
  42. Mercer JG, Archer ZA. Diet-induced obesity in the Sprague-Dawley rat: dietary manipulations and their effect on hypothalamic neuropeptide energy balance systems. *Biochem Soc Transact.* 2005;33:1086.
  43. Davidson EP, Coppey LJ, Calcutt NA, Oltman CL, Yorek MA. Diet Induced Obesity in Sprague Dawley Rats Causes Microvascular and Neural Dysfunction *Diabetes Metab Res Rev.* 2010 May; 26(4): 306-18.
  44. Obrosova IG, Ilnytska O, Lyzogubov VV, Pavlov IA, Mashtalir N, Nadler JL, Drel VR. Effects of "Healthy" Diet and Aldose Reductase Inhibition. *Diabetes.* 2007;56:2598-608.
  45. Gao Z, Wang ZQ, Zhang X, Butler AA, Zuberi A, Gawronska-Kozak B, Lefevre M, York DA, Ravussin E, Berthoud HR, McGuinness OP, Cefalu WT, Ye J Inactivation of PKC $\theta$  leads to increased susceptibility to obesity and dietary insulin resistance in mice. *Am J Physiol Endocrinol Metab.* 2007;292:E91-4.
  46. Ishii Y, Ohta T, Sasase T, Morinaga H, Hata T, Miyajima K, Katusda Y, Masuyama T, Shinohara M, Kakutani M, Matsushita M A high-fat diet inhibits the progression of diabetes mellitus in type 2 diabetic rats. *Nutr Res.* 2010 ;30(7):483-91.

47. Woo MN, Bok SH, Lee MK, Kim HJ, Jeon SM, Do GM, Shin SK, Ha TY, Choi MS. Anti-obesity hypolipidemic effects of a proprietary herb fiber combination (S&S PWH) in rats fed high-fat diets. *J Med Food*. 2008;11:169-78.
48. Kamal AA, Mohamed AN. Effect of Carnitine and herbal mixture extract on obesity induced by high fat diet in rats. *Diabet & Metab Syndr*. 2009;1:1-17.
49. Grundy SM. Metabolic complications of obesity. *Obesity, Metabolic Syndrome, and Cardiovascular Disease*. *J Clin Endo & Metab*. 2004;89(6):2595-2600.
50. Leopold JA, Loscalzo J. Oxidative mechanisms and athero-thrombotic cardiovascular disease. *Drug Discov*. 2008;5:5-5.
51. Sonta T, Inoguchi T, Tsubouchi H, Sekiguchi N, Kobayashi K, Matsumoto S, Utsumi H, Nawata H. Evidence for contribution of vascular NAD(P)H oxidase to increased oxidative stress in animal models of diabetes and obesity. *Free Radic Biol Med*. 2004;37:115-115.
52. Keaney JF, Larson MG, Vasani RS, Wilson PWF, Lipinska I, Corey D. Obesity and systemic oxidative stress: clinical correlates of oxidative stress in the Framingham study. *Arterioscler Thromb Vasc Biol*. 2003;23:434-434.
53. Oltman CL, Davidson EP, Coppey LJ, Kleinschmidt TL, Lund DD, Yorek MA. Attenuation of vascular/neural dysfunction in Zucker rats treated with Enalapril or Rosuvastatin. *Obesity*. 2008;16:82-89.
54. Singleton JR, Smith AG, Russell J, Feldman EL. Polyneuropathy with impaired glucose tolerance: implications for diagnosis and therapy. *Curr Treatment Options Neurol*. 2005;7:33-42.
55. Summer CJ, Sheth S, Griffin JW, Cornblath DR, Polydefkis M. The spectrum of neuropathy in diabetes and impaired glucose tolerance. *Neurology*. 2003; 60:108-111.
56. Smith AG, Singleton JR. Impaired glucose tolerance and neuropathy. *Neurologist*. 2008; 14:23-9.
57. Lee RH, Dellon AL. Insulin Resistance. Does it play a role in peripheral neuropathy? *Diabetes Care*. 1999; 22(11): 1914-5.
58. Grote C W, Morris J K, Ryals J M, Geiger P C, Wright DE. Insulin Receptor Substrate 2 Expression and Involvement in Neuronal Insulin Resistance in Diabetic Neuropathy. *Exp Diabetes Res*. 2011; 2011: 212571.
59. Hsueh WA, Quiñones MJ. Role of endothelial dysfunction in insulin resistance. *The American Journal of Cardiology*. 2003;92(4) supplement 1:10J-17J.
60. Davidson EP, Coppey LJ, Kleinschmidt TL, Oltman CL, Yorek MA. Vascular and Neural Dysfunctions in Obese Zucker Rats: Effect of AVE7688 *Exp Diabetes Res*. 2009; 2009: 912327.
61. Sima AAF, Sugimoto K: Experimental diabetic neuropathy: an update. *Diabetologia*. 1999;42:773-88.
62. Chattopadhyay J, Thompson EW, Schmid HH: Nonesterified fatty acids in normal and diabetic rat sciatic nerve. *Lipids*. 1992;27:513-7.
63. de Lau LM, Bornebroek M, Witteman JC, Hofman A, Koudstaal PJ, Breteler MM. Dietary fatty acids and the risk of Parkinson disease: the Rotterdam study. *Neurology*. 2005 ;28;64(12):2040-5.
64. Martinez M, Vazquez E. MRI evidence that docosahexaenoic acid ethyl ester improves myelination in generalized peroxisomal disorders. *Neurology*. 1998;51(1):26-32.
65. Gibbons A. American Association of Physical Anthropologists Meeting. Humans' head start: new views of brain evolution. *Science*. 2002;296:835-7.
66. Lauritzen I, Blondeau N, Heurteaux C, Widmann C, Romey G, Lazdunski M. Polyunsaturated fatty acids are potent neuroprotectors. *The EMBO Journal*. 2000;19:1784-1793.
67. Youdim KA, Martin A, Joseph JA. Essential fatty acids and the brain: possible health implications. *International Journal of Developmental Neuroscience*. 2000;18:383-399.
68. Leaf A, Kang JX, Xiao YF, Billman GE, Voskuyl RA. Experimental studies on antiarrhythmic and antiseizure effects of polyunsaturated fatty acids in excitable tissues. *Journal of Nutritional Biochemistry*. 1999;10:440-448.
69. Faas FH, Carter WJ. Altered fatty acid desaturation and microsomal fatty acid composition in the streptozotocin diabetic rats. *Lipids*. 1980;15:953-61.
70. Hishinuma T, Yu GS, Takabatake M, Nakagawa Y, Ita K, Nishikawa M, Ishibashi M, Suzuki K, Matsumoto M, et al. Analysis of the thromboxane/prostacyclin balance in human urine by gas chromatography/selected ion monitoring: abnormalities in diabetics. *Prostaglandins Leukot Essent Fatty Acids*. 1996;54:445-9.
71. Silberbauer K, Scherthaner G, Sinzinger H, Piza-Katzer H, Winter M. Decreased vascular prostacyclin in juvenile-onset diabetes. *N Engl J Med*. 1979;300:366-7.
72. Desvergne B, Wahli W. Peroxisome proliferator-activated receptors: nuclear control of metabolism. *Endocr Rev*. 1999;20:649-88.
73. Kitajka K, Puskas LG, Zvara A, Hackler L Jr, Barcelo-Coblijn G, Yeo YK, Farkas T. The role of n-3 polyunsaturated fatty acids in brain: modulation of rat brain gene expression by dietary n-3 fatty acids. *Proc Natl Acad Sci USA*. 2002;99:2619-24.

74. Horrobin DF. Fatty acid metabolism in health and disease: the role of L-6-desaturase. *Am J Clin Nutr.* 1993;57:732S-7S.
75. Horrobin DF. Essential fatty acids. psychiatric disorders and neuropathies. In: Horrobin DF, ed. *Omega-6 essential fatty acids: Pathophysiology and roles in clinical medicine.* New York: Alan Liss, 1990:305-19.
76. Simopoulos AP, Leaf A, Salem N Jr Workshop on the Essentiality of and Recommended Dietary Intakes for Omega-6 and Omega-3 Fatty Acids. *J Am Coll Nutr.* 1999;18(5):487-9.
77. Natarajan R, Nadler JL. Lipid inflammatory mediators in diabetic vascular disease,"Arteriosclerosis, Thrombosis, and Vascular Biology. 2004; 24(9): 1542–8.
78. Purves T, Middlemas A, Agthong S, A role for mitogen-activated protein kinases in the etiology of diabetic neuropathy. *FASEB Journal.* 2001; 15(13): 2508–14.
79. Price SA, Agthong S, Middlemas AB, Tomlinson DR. Mitogen-activated protein kinase p38 mediates reduced nerve conduction in experimental diabetic neuropathy: interactions with aldose reductase. *Diabetes.* 2004; 53(7): 1851–6.
80. LeRoith D, Fonseca V, Vinik A. Metabolic memory in diabetes—focus on insulin. *Diabetes/Metabolism Research and Reviews.* 2005; 21(2):85–90.
81. Dyck P1, Thomas P, Coppey LJ, Gellert JS, Davidson EP, Dunlap JA, Lund DD, Yorek MA. Effect of antioxidant treatment of streptozotocin-induced diabetic rats on endoneurial blood flow, motor nerve conduction velocity, and vascular reactivity of epineurial arterioles of the sciatic nerve. *Diabetes.* 2001;50:1927-37.
82. Coppey LJ, Davidson EP, Rinehart TW, Gellert JS, Oltman CL, Lund DD, Yorek MA. ACE inhibitor or angiotensin II receptor antagonist attenuates diabetic neuropathy in streptozotocin-induced diabetic rats. *Diabetes.* 2006;55:341-8.
83. Davidson EP, Kleinschmidt TL, Oltman CL, Lund DD, Yorek MA. Treatment of streptozotocin-8/11/2012 induced diabetic rats with AVE7688, a vasopeptidase inhibitor, on vascular and neural disease. *Diabetes.* 2007;56:355-62.
84. Cai H, Griendling KK, Harrison DG. The vascular NAD(P)H oxidases as therapeutic targets in cardiovascular diseases. *Trends Pharmacol Sci.* 2003; 24:471-8.
85. Doupis J, Lyons TE, Wu S, Gnardellis C, Dinh T, Veves A. Microvascular reactivity and inflammatory cytokines in painful and painless peripheral diabetic neuropathy. *Journal of Clinical Endocrinology and Metabolism.* 2009; 94(6): 2157–63.
86. Nunemaker CS, Chen M, Pei H. 12-Lipoxygenase-knockout mice are resistant to inflammatory effects of obesity induced by western diet. *American Journal of Physiology.* 2008; 295(5): E1065–75.
87. Ferrucci L, Cherubini A, Bandinelli S, Bartali B, Corsi A, Lauretani F, Martin A, Andres-Lacueva C, Senin U, Guralnik JM. Relationship of plasma polyunsaturated fatty acids to circulating inflammatory markers. *J Clin Endocrinol Metab.* 2006 Feb;91(2):439-46.
88. Kapoor R, Huang YS. Gamma linolenic acid: an antiinflammatory omega-6 fatty acid. *Curr Pharm Biotechnol.* 2006 Dec;7(6):531-4.
89. Calder VL, Bondeson J, Brennan FM, Foxwell BM, Feldmann M. Antigen-specific T-cell downregulation by human dendritic cells following blockade of NF-kappaB. *Scand J Immunol.* 2003;57(3):261-70.
90. Di Iorio A, Cherubini A, Volpato S, Sparvieri E, Lauretani F, Franceschi C, Senin U, Abate G, Paganelli R, Martin A, Andres-Lacueva C, Ferrucci L. Markers of inflammation, vitamin E and peripheral nervous system function: the InCHIANTI study. *Neurobiol Aging.* 2006;27(9):1280-8..
91. Simopoulos AP, Omega-3 fatty acids in inflammation and autoimmune diseases. *Am Coll Nutr.* 2002; 21 (6): 495-505
92. Natarajan R, Nadler JL, Lipoxygenases and lipid signaling in vascular cells in diabetes, *Frontiers in Bioscience,* 2003;. 8:s783–s95.

## Change Management Challenges in Nursing and Midwifery Schools: A qualitative study of managerial experiences

Alice Khachian<sup>1</sup>, Hومان Manoochehri<sup>2</sup>, Mehrnoosh Pazargadi<sup>3</sup>, Safar Ali Esmaeili Vardanjani<sup>4</sup>

- 1- PhD student of nursing, School of Nursing & Midwifery, Shahid Beheshti University of Medical Sciences, Tehran, Iran.
- 2- PhD, Assistant Professor, School of Nursing & Midwifery, Shahid Beheshti University of Medical Sciences, Tehran, Iran.
- 3- PhD, Associate Professor, School of Nursing & Midwifery, Shahid Beheshti University of Medical Sciences, , Tehran, Iran.
- 4- Ms in nursing education, Shahrekord university of Medical Science, Shahrekord, Iran.  
[dr.houmanmanoochehri@gmail.com](mailto:dr.houmanmanoochehri@gmail.com)

**Abstract:** The purpose of this study was to explain the situation and perspectives of managers regarding change in nursing and midwifery faculties. This study was conducted according to a qualitative approach; in fact, a descriptive exploratory approach was applied with triangulation. Snow ball sampling was used in this study. The subjects were faculty members of the nursing schools in Tehran, and the inclusion criteria included at least 1 year of experience as a faculty member. In the qualitative phase, no variables were measured. Data were gathered by semi-structured interviews in which a guide and field notes were used. Data were considered to be saturated after observing the repetition of codes. Qualitative conventional content analysis was used for data analysis. Trustworthiness was achieved by prolonged field experience, member check, peer check and sharing the content with two experts in qualitative research. Ten participants (7 females and 3 males) between the ages of 38 and 54 were interviewed. Two of them had Master's degrees, and eight had PhD degrees in nursing; only three of them were in high-level management of their faculties. After the interviews, conceptual codes were extracted, and a few suggested themes were classified, including challenges in change management, such as field of concentration in management, managers' characteristics and attitudes toward change. Accordingly, the concept of change management was postulated as the purpose of this study; furthermore, its influencing factors were identified. The implication of the study is that it may be used in nursing and midwifery faculties as a model for organizational culture. Imposing change in an educational organization without having a proper model of change management will facilitate the achievement of the desired change outcome.

[Khachian A, Manoochehri H, Pazargadi M, Esmaeili Vardanjani SA. **Change Management Challenges in Nursing and Midwifery Schools: A qualitative study of managerial experiences.** *Life Sci J* 2012;9(3):2265-2269] (ISSN:1097-8135). <http://www.lifesciencesite.com>. 403

**Keywords:** Change, Change management, nursing faculties

### 1. Introduction

"Nothing is stable except change itself" (Ellis & Hartley, 2008). The greatest problem every organization faces today is change and transformation, which makes change management one of the most important issues of management (Carnall, 2001; Masoudi et al., 2012). On the other hand, adoption of change and realization of transformation are the most important factors in the survival and further development of a person or an organization because an organization is a subsystem of a social system and of the large-scale global system. While the whole system is in the process of change and development, the subsystems have no choice but to adapt and adjust themselves to the transformation of the larger system (Sohrabi, 2009). Therefore, today, managers face the fundamental issue of organizational improvement and constantly deal with the issue of change (Robbins, 2007).

In fact, the interests of an organization somehow lead to the fundamental reconsideration of issues within itself, which will affect its values, presumptions and attitudes in such a way that it can adjust and coordinate itself to rapid change. The term organizational improvement refers to the improvement and development of potential within an organization to the extent that it reaches and maintains its optimum level of function. Organizational improvement is a constant process of problem solving, which requires cooperation among its members and experts of behavioral sciences. According to the principles of organizational improvement, there is always room for further improvement and development even for organizations functioning at their optimum level (Drucker, 1999).

Taking into account that the adoption of change is a necessity for organizational improvement

and that it means transformation of the activities and structure of a system (Carnall, 2001), employing objective knowledge and skills in making planned changes is unavoidable. As nursing and midwifery schools are scientific environments and the faculty members are knowledgeable and well informed, faculty members can cooperate in being exemplary models of change managers and lead their organizations towards the achievement of their goals (Zerwekh & Claborn, 2009).

In fact, organizational improvement is a process brought about through planned change. Planned change includes all aspects of an organization, namely the structure of the organization and its management processes as well as its programming and communications. The purpose of planned change is the realization of effective change in the organization as a whole or in parts of it, and/or in its temporary subsystems, such as committees, etc. Moreover, following planned change, an educational organization transforms into a learning organization, and its academic members promote the organization through learning.

Managers can be called the agents of change, as they are responsible for creating an optimal physical and intellectual environment for their employees who strive to reach their personal and organizational goals by employing their capabilities in a harmonious situation. Managers should create change by controlling, affecting and providing facilities. Any change, limited or comprehensive, has to be accurately planned and established through a process to be predictable. Therefore, to make changes in an educational organization, such as a nursing and midwifery school, there has to be a model that enables the manager to lead the planned change (Baly, 1994).

Change management is essential for making changes. Effective change management should be based on a profound understanding of an organization's nature as a system, interactions within its structure, and processes of activities and culture (Shokati A, 2012). The basis of change is to make the educational system dynamic, which itself requires the behavioral dynamism of its participants. It should be noted that differences in the educational systems of various countries at different periods of time impose different types of change (Shirazi, 1994).

Change is a permanent, dynamic and systematic process requiring knowledge, participation and cooperation. In fact, the change process does not have a beginning or end and is not linear; it has a rotational mode. Paying attention to the viewpoints of beneficiaries and those people who are most affected by change is especially important. Because change is an act of making them feel self-confident, respected

and honored for their human dignity, their resistance toward change will be minimized. Therefore, the conscious participation of the employees, students and scholars of an organization in different phases of change is essential. Accordingly, change management in organizations, in general, and faculties, in particular, seems necessary to promote the learning environment and transform the organization into an improved source of scientific advancement, innovation and skills. The establishment of planned change involves all aspects of an organization, and it is realized by revision, learning and promotion.

## 2. Material and Methods

In this qualitative study, the triangulation method was applied. Accordingly, the details of variables were collected and used for the description and assessment of specific situations and activities. Outlooks, viewpoints and facts were the variables collected by interviews or questionnaires (LoBiondo – Wood & Haber, 2006). The triangulation method was applied as described previously (Strubert & Carpenter, 2007), and determine the final phrases and indicators of the change management model, the methodological approach was also utilized (LoBiondo-Wood & Haber, 2006; Sheikholeslami et al., 2012). The population of this study included faculty members and staff of Type 1 Nursing and Midwifery schools affiliated with the Ministry of Health and Medical Education in Tehran, and the sample population was selected according to the snow ball method of sampling.

Inclusion criteria for faculty members were at least 1 year of experience as a faculty member and being in low, middle or high managerial positions in nursing and midwifery faculties, and for employees, at least two years of work experience in the faculties. In phase I, data were gathered from faculty members and employees through semi-structured interviews and focus groups with the subjects. During the interviews and meetings, interview guides and field notes were used. Then, content analyses of the interviews were performed to pinpoint the views and outlooks of the participants.

Managers were visited one-by-one, the necessary explanations regarding the study and their cooperation were presented and an appointment made for a follow-up interview in their workplace. In addition, after coordinating with the faculty administration and the employees regarding the appropriate times, a group interview with the employees was carried out. Moreover, during the interview sessions and after introducing and explaining the goals of the research, emphasizing the confidentiality of the data and obtaining their informed consent, the researcher held audio recorded

group or individual interviews. Then, the recorded interviews were listened to several times, and the data were transcribed completely. The transcribed data were typed, and their accuracy checked again with the recorded data, enabling the researcher to organise the results.

After this phase, the transcribed data served as the data source for the analysis in the present study. Conventional content analysis was used to analyse the data. At the beginning of content analysis, the conceptual units were distinguished, and then the relevant codes were extracted and categorised according to their similarities. The subcategories were identified with data saturation, and, finally, the main concepts were determined. This process is still being reviewed, and the codes are being revised. In addition to the sessions with the supervisors, researchers shared the study with 2 other persons with PhD degrees in nursing, a professor experienced in qualitative research and 2 PhD graduates in nursing, and the researchers have been in constant contact with all of them by email. The researchers drew upon their viewpoints in interviews and data analysis. Accordingly, necessary changes and adjustments were made in interviews, and some codes, divisions and subdivisions were omitted or added.

The validity and reliability of the study have been based on 4 key factors: credibility, dependability, conformability and transferability. Credibility means that the transcription of the interviews is acceptable to the participants. In this study, the continuous involvement of the subject matter, the gathered data, the modifications suggested by the supervisor regarding the process and the analysis of interviews and extracted data were all taken into account. Moreover, the content of the interviews, the extracted codes and subdivisions were discussed with a few participants and 2 PhD nursing graduates, and their viewpoints were also taken into account.

Several methods were combined and applied in data gathering (individual interviews, group interviews and field notes), and two types of locations were also used (nursing and midwifery schools). In selecting the samples, there has been an attempt to consider a variety of groups, i.e., managers from different managerial levels (lower, middle and higher) and employees with different positions, responsibilities and work experiences (Strubert & Carpenter, 2007; Boswell & Cannon, 2007; Adib Haj Baqeri et al., 2007). To achieve consistency, there was an attempt to combine data gathering methods (Strubert & Carpenter, 2007; Boswell & Cannon, 2007). For verifiability, all of the activities, including different phases of activities and the quality of

gathered data, were carefully recorded (Strubert & Carpenter, 2007). And finally, to achieve transmissibility of the research findings, there was an attempt to discuss the obtained information with 4 persons who had the same positions as the participants in the research (Strubert & Carpenter, 2007).

### 3. Results

Ten participants (7 females and 3 males) between the ages of 38 and 54 were interviewed. 8 had PhD degrees in nursing, and 2 had MS degrees in nursing. Participants held lower, 3 held middle and 3 held higher levels of managerial positions. 7 participants in the study had also participated in change management committees.

The text of the interviews was analysed by the Qualitative Content Analysis method (Polit & Beck, 2006), (Graneheim & Landman, 2004), and their conceptual codes were extracted and classified under the main headings and divided into categories explaining the main concepts of the headings. To explain the main concepts clearly, the expressions used by the participants are presented, which confirm the selection of the main headings. The resulting three main concepts related to the challenges of change management include the centralization level of management, which is classified under *external environment*, the role and characteristics of the manager, classified under *managerial factors*, and attitude, which is classified under *organizational factors*.

#### Centralization level of management:

The participants of the present research generally believed that the centralization level of the management in nursing and midwifery schools could be a restrictive factor in adopting change management models. For instance, a participant said in an interview:

“Changes occur in educational organizations. As our educational system is centralized, changes depend on the decisions of the higher managerial levels, and if an educational organization intends to adopt innovative changes, it is restricted by the centralized system.” (Lower managerial level, 2 years of managerial experience).

Another participant said:

“Another existing obstacle is the central organization or higher managerial level itself from which our nursing and midwifery schools receive orders. The faculties obey orders of the university, and the university obeys orders from the ministry; this means that the faculty cannot make decisions by itself.” (Middle managerial level, 4 years of managerial experience).

#### Regarding the regulations, the participants said:

“Apparently, these circulars are creating change. Neither I nor others believe in these regulations, as they are short-term or formal, and we keep up appearances. Changes will not get internalised easily. Many years should pass, they should be proved and adopted by others and, then they become standard. When normalised, although proved, it still is not a change; it is not more than an instruction and is just a procedural change.” (Lower managerial level, 8 years of managerial experience).

“I do not consider the implementation of regulations as a change... Managers and responsible persons of the faculties should have independence in decision making so that they can access the facilities that the faculties require. In my opinion, change cannot be adopted without system decentralization and solving the problem of independence.” (Higher managerial level, 20 years of managerial experience).

#### **The role and characteristics of a manager**

The participants in the study specifically emphasized the role and characteristics of higher-level managers in leading change management. Some views of the participants in this regard are mentioned below:

“If the higher-level manager himself believes in adoption of changes and innovations, he/she will welcome the change management and may even apply the new ideas.” (Lower managerial level, PhD, 8 years of managerial experience).

“...if the senior manager believes in adopting change and supports it, he/she will make the change a success.” (Lower managerial level, MS, 8 years of managerial experience).

#### **Changes in attitude**

Regarding changes in attitude, the participants expressed views that can play an important role in change management. A few examples of the views are presented below:

“The attitudes, ideas, beliefs and approaches have not changed so far. We want to change the structure and system, but the infrastructures are still not ready”. (Lower managerial level, PhD, 8 years of managerial experience).

“Changing anything requires wisdom, optimism and risk-taking... People need to feel the necessity of change with their entire being.” (Lower managerial level, 1 year of managerial experience).  
 “No one can urge a professor to teach according to circulars, which means that the professor should believe in and be optimistic about the new methods of teaching.” (Higher managerial level, 20 years of managerial experience).

#### **4. Discussions**

Change means transforming from one condition to another, and it is the process of transforming attitudes, views, goals and behaviors, as

well as other individual and organizational characteristics (A group of management scholars, 2000). The purpose of change management is to keep employees and the whole organization prepared for learning and constant improvement. Change management thinks of the future (Management Total site, 2009).

The results of this study showed that taking advantage of a model for change management is a complex process in which leadership; management, human resources training and provision of facilities are important factors. There are several obstacles to applying change management. The main obstacle is the centralized system of management. In 2004, Stroh, in his studies, indicated the importance of the strategy adopted for applying change in an organization. The application of a certain types of change strategy becomes very effective when it is related to the employees of an organization and results in the formation of improved internal and external communication in the management of an organization.

According to Stroh's studies, when facing environmental changes, organizations need to communicate more effectively. In this regard, they have to take advantage of communication management in applying changes, which leads to the formation of a new attitude toward change in the organization. In structural changes, such an attitude has special goals and is fully controlled by change management, which reduces resistance, supports innovations and facilitates the process of change. Moreover, he points to the importance of freedom in decision making, which, in a way, refers to the decentralization of the faculties.

Another challenge in the adoption of a model for change management in faculties is the role and characteristics of the manager. In this regard, Andrews and his colleagues (2008), in their qualitative study, reviewed the change management experiences of managers in educational organizations. Their results emphasized the importance of the individual and organizational attitudes, skills and knowledge of managers in change management that affect the adoption of change strategy by the managers and could lead to positive or negative results. Considering the studies of Andrews and colleagues and the present study, it is evident that the risk-taking and change-initiating characteristics of a manager are especially important and can turn him/her into a pioneer that makes changes by applying change management.

Finally, the third challenge to which the present study points is the change in the attitude of managers and their subordinates who need to believe in change and become optimistic about the results.

Martin (2002), in his qualitative study, "Adjustment of employees to the changes in their organization," investigated the adaptation process employees experience during changes in their organization. He presented and examined a model of change adoption that confirmed the importance of the role of employees in the process of change. His study was designed to achieve a theoretical understanding of the adjustment of employees to the process of change in an organization.

He also wanted to determine the difference of understanding from their environment as subordinates and the level of adaptation indicators. Besides, the process of appointing change managers of an organization was determined through examining the practical values of experiential findings. In general, the final model indicated that having a positive understanding of their manager, feeling supported by him and having a positive understanding of change all bring about a better adjustment of individuals to the changes occurring in the organization where environmental factors have direct and indirect effects.

Finally, it should be acknowledged that, to adopt an appropriate model and strategy for change in an organization, a full understanding of the organization and its components is necessary. For this purpose, the concept of change management has been developed to facilitate making changes in an organization by identifying factors that affect the process of change.

#### **Acknowledgements:**

This is an original article and this paper is a part of PhD dissertation. The cooperation and support of the faculty and staff of the School of Nursing and Midwifery affiliated with Shahid Beheshti Medical University and all the participants who helped me in conducting this research are highly appreciated.

#### **Corresponding Author:**

Dr. Houman Manoochehri

Assistant Professor, School of Nursing & Midwifery  
Shahid Beheshti University of Medical Sciences  
Tehran, Iran.

E-mail: [dr.houmanmanoochehri@gmail.com](mailto:dr.houmanmanoochehri@gmail.com)

#### **References**

1. Ellis, J.R. & Hartley, C.L. 2004. Nursing in Today's World. 8<sup>th</sup> edition, Lippincott Williams and Wilkins, Philadelphia.
2. Carnall, C. 2001. Managing change, translated into Persian by Alavi, A., State Management Training Centre, Tehran, Iran.
3. Msoudi R, Esmaili Vardanjani SA, Rabiei L, Moghadassi J, Khayri F, Rahimi Madiseh M. A group-foundation exercise schedule on quality of life and well-

- being in older men and women. Indian Journal of Science and Technology 2012: 5 (2): 2165-2169.
4. Sohrabi, Z. *et al.* 2009. Step-by-step improvement of universities based on Baldrige Model of excellence, NehzatPouya, Tehran.
5. Robbins, S.P. 2007. Essentials of organizational behaviour, translated into Persian by Parsaian, A. & Erabi, M., The Cultural Research Office, Tehran, Iran.
6. Drucker, P.F. 1999. Management challenges for the 21<sup>st</sup> century, 1<sup>st</sup> edition. Butterworth Heinemann, Oxford.
7. Zerwekh, J.A. & Claborn, J.C. 2009. Nursing Today Transition and Trends. 6th edition, Saunders Elsevier, Canada
8. Baly, M.E. 1994. Nursing and Social Change. 3<sup>rd</sup> edition, Routledge, London.
9. Shokati AM, Hassani P, Manoochehri H, Esmaili vardanjani SA. 2012. The Lived Experience of Iranian Caregivers of Comatose Patients. Life Science Journal 2012: 9 (3) 1656-1662.
10. Shirazi, A. 1994. Theories and applications of educational management, JahadDanehsghahi, Mashad.
11. LoBiondo-Wood G. & Haber, J. 2006. Nursing research: methods, critical appraisal and utilization. 6<sup>th</sup> edition, Mosby, USA.
12. Sheikholeslami F, Masole SR, Rafati P, Esmaili Vardanjani SA, Yazdani Talami MA, Khodadadi N. The relationship between the religious beliefs and the feeling of loneliness in elderly. Indian Journal of Science and Technology 2012: 5 (3): 2411-2416.
13. StreubertSpeziale, H.J. & Carpenter Rinaldi, D. 2007. Qualitative research in nursing, advancing the humanistic imperative, 4th edition, Lippincott-Williams & Wilkins, Philadelphia.
14. Boswell, C. & Cannon, Sh. 2007. Introduction to nursing research, incorporating evidence-based practice. Jones and Bartlett, Boston.
15. Adib Haj Baqeri, M., Parvizi, S. and Salsali, M. 2007. Qualitative research methods, Bashari, Tehran, Iran.
16. Polit D.F. & Tatano Beck, Ch 2006. Essentials of Nursing Research, Methods, Appraisal, and Utilization, 6<sup>th</sup> edition. Lippincott-Williams & Wilkins, Philadelphia.
17. Graneheim U.H. & Lundman, B. 2004. Qualitative content analysis in nursing research: concepts, procedures and measures to achieve trustworthiness. Nurse Education Today, Vol. 24 (2), pp. 105-112.
18. [http://www.Management Total Site-AthIR.blogfa.Com](http://www.ManagementTotalSite-AthIR.blogfa.Com) [2 January 2010].
19. Stroh, Ursula Marie 2004. An Experimental Study of Organizational Change and Communication Management, PhD Thesis in Communication Management, Department of Marketing and Communication Management, University of Pretoria. [Online].
20. Andrews, J., Cameron, H. & Harris, M. 2008. All change? Managers' experience of organizational change in theory and practice. Journal of Organizational Change Management, Vol. 21 (3), pp. 300-314.
21. Martin A. J. Employee adjustment during organizational change: the role of climate, organizational level and occupation, PhD Thesis in Applied Psychology, School of Applied Psychology, University of Griffith. 2002[online].

1/26/2012



## Use Of Fuzzy Logic For Risk/Benefit Assessment In Medical/Biological Cases

Mariam K Hafshejani<sup>1</sup>, Manochehr Sattari Naeini<sup>2</sup>, Aboosaleh Mohammadsharifi<sup>3</sup>, Mohammadtaghi Yahiaipoor<sup>3</sup>, Ameneh Langari\*<sup>4</sup>

<sup>1</sup>Shahrekord University of Medical Sciences, Shahrekord, Iran

<sup>2</sup>Department of Biology, Naein Branch, Islamic Azad University, Naein, Iran

<sup>3</sup>Engineering Group, Ramsar Branch, Islamic Azad University, Ramsar, Iran

<sup>4</sup>North Khorasan University of Medical Sciences, Bojnurd, Iran

Corresponding author email: [amenehlangari@yahoo.com](mailto:amenehlangari@yahoo.com)

**Abstract:** In recent decade safety of medical and biological products has been concerned in the light of benefit/risks and risk assessment. For new medical products and new drugs, unanticipated side effects that rise after consuming the new product is a dominant factor in decision making. The aim of this project is to design a fuzzy inference system for risk assessment of medical cases. Classical risk assessment in the crisp space precisely determines boundary sharply dissects safe state from unsafe one. In contrary, fuzzy set shows smooth change from safe to unsafe state. It indicates that safety can be considered as a fuzzy issue because plant safety cannot be strictly classified as safe or unsafe, as inherent hazards always occur.

[Hafshejani M K, Sattari Naeini M, Mohammadsharifi A, Yahiaipoor M. **Use of Fuzzy Logic for Risk/Benefit Assessment in Medical/Biological Cases.** *Life Sci J* 2012;9(3):2270-2273] (ISSN:1097-8135). <http://www.lifesciencesite.com>. 404

**Keywords:** Medical risk/benefit, Risk assessment, Fuzzy logic

### 1. Introduction

Today's healthcare products are developed and used within a complex system involving a number of key participants (Report to the FDA commissioner, 1999). The choice to use a drug, biological product, or device involves balancing the benefits to be gained with the potential risks of using a product (Report to the FDA commissioner, 1999). In recent decades safety of medical products have been concerned in the light of several types of risks and risk assessment. For new products, unanticipated side effects that rise after consuming the new product is a dominant factor. In addition, FDAs focused on ensuring the appropriate use of products in medical practice. Some reports have focused on the human/economic costs of medication errors, as well as serious adverse events that have occurred even when a medical product has been used appropriately (Report to the FDA commissioner, 1999). Risks have different source, hence effective management of each is different. To understand the complexity of risk assessment and management of medical products, it is important to understand the types/source of risks and its assessment. Figure 1 shows, FDA evaluates the risks/benefits for the population, the prescriber manages risks/benefits for the individual and patients make decisions about treatment choices based on their personal assessment of benefits/risks.

Security in any system should be commensurate with its risks. However, the process to determine which security controls are appropriate and cost effective is quite often a complex and sometimes a

subjective matter. One of the prime functions of security risk analysis is to put this process onto a more objective basis. There are a number of distinct approaches to risk analysis. However, these essentially break down into two types: quantitative and qualitative ([www.security-risk-analysis.com](http://www.security-risk-analysis.com)) Quantitative risk assessment employs two fundamental elements; the probability of an event occurring and the likely loss should it occur. Quantitative medical risk analysis makes use of a single figure produced from these elements. This is called the 'Annual Loss Expectancy (ALE)' or the 'Estimated Annual Cost (EAC)'. This is calculated for an event by simply multiplying the potential loss by the probability. It is thus theoretically possible to rank events in order of risk (ALE) and to make decisions based upon this. The problems with this type of risk analysis are usually associated with the unreliability and inaccuracy of the data ([www.security-risk-analysis.com](http://www.security-risk-analysis.com)) Probability can rarely be precise and can, in some cases, promote complacency. In addition, controls and countermeasures often tackle a number of potential events and the events themselves are frequently interrelated. Notwithstanding the drawbacks, a number of organisations have successfully adopted quantitative risk analysis ([www.security-risk-analysis.com](http://www.security-risk-analysis.com)).

In this paper, a fuzzy logic system (Zadeh, 1965; 1968; 1973; 1984; Ramadan *et al.* 2012; Hanafy, 2011; Emarah *et al.* 2011;) is designed to perform a systematic risk assessment in medical globe. The

presented system is applied for a case of medical risk analysis and the results are assessed and discussed.

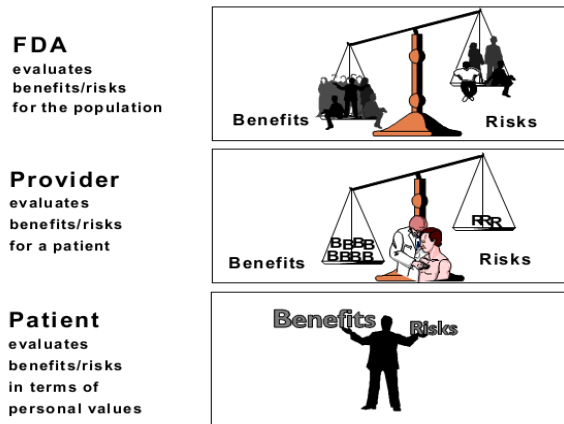


Figure 1. On balancing risks and benefits, FDA evaluates the risks/benefits for the population, the prescriber manages risks/benefits for the individual and patients make decisions about treatment choices based on their personal assessment of benefits/risks (Report to the FDA commissioner, 1999).

**2. Constructed Fuzzy Inference System**

The category of frequency of consequence is represented by numbers from 1 to 5, where category 1 is for very low frequency and opposite category 5 is for very high frequency. The member functions for frequencies are shown in figure 2.

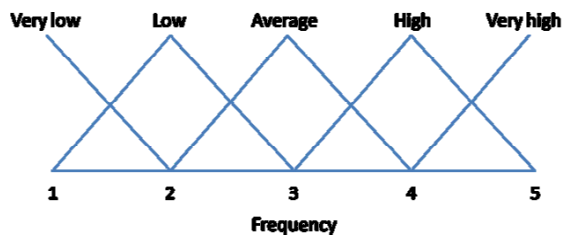


Figure 2. Fuzzy Set for the definition of Frequency

The category of severity of consequence is represented by numbers from 1 to 5, where category 1 is for negligible severity and opposite category 5 is for catastrophic severity.

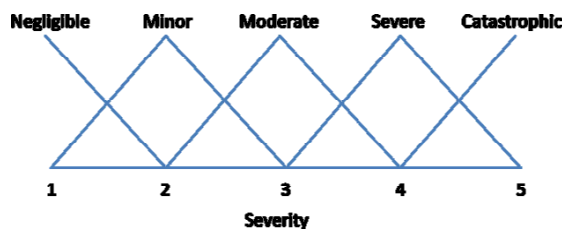


Figure 3. Fuzzy set for the definition of Severity

The category of medical risk is represented by numbers from 0 to 10 as demonstrated below.

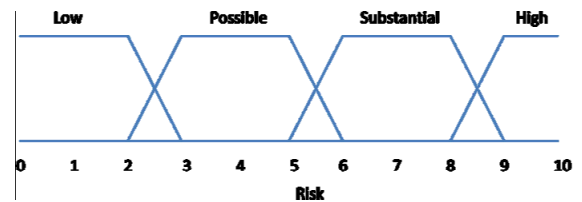


Figure 4. Fuzzy set for the definition of Risk

**3. Fault tree**

For this work, a simple fault tree could be considered as figure 5. This is a typical fault tree to be applied for a systematic fuzzy interface.

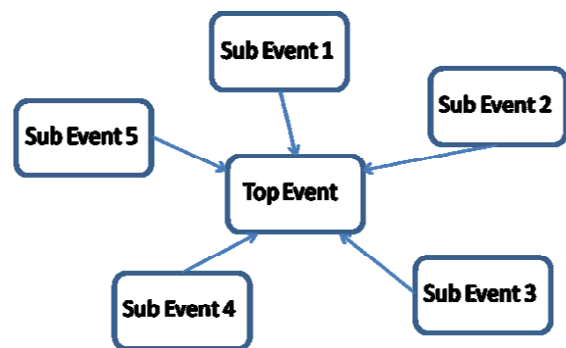


Figure 5. Typical fault tree

**4. Rule Table**

A set of 25 rules is prepared for this work. As an example “If Frequency is high and Severity is moderate then the risk is substantial”. Such a rule table is constructed to predict the state of risk assessed for different states in severity and frequency. The performed table of variation in risk can be as table 1.

**5. Data generation**

We can normalize data points to be within a specific range. In this case, data points are normalized to the range of [0,1]. Although, raw data points could be used as they are all in the range of 1 to 5.

Table 1. A part of constructed fuzzy data base

Some sets of the fuzzy data base (32768 points)					
Frequency of medical sub event 1	Frequency of medical sub event 2	Frequency of medical sub event 3	Frequency of medical sub event 4	Frequency of medical sub event 5	Overall frequency
1.25 (0.75 V.low, 0.25 Low)	1.25 (0.75 V.low, 0.25 Low)	1.25 (0.75 V.low, 0.25 Low)	1.25 (0.75 V.low, 0.25 Low)	1.25 (0.75 V.low, 0.25 Low)	1.375
1.25 (0.75 V.low, 0.25 Low)	1.25 (0.75 V.low, 0.25 Low)	1.25 (0.75 V.low, 0.25 Low)	1.25 (0.75 V.low, 0.25 Low)	1.75 (0.25 V.low, 0.75 Low)	1.425
1.25 (0.75 V.low, 0.25 Low)	1.25 (0.75 V.low, 0.25 Low)	1.25 (0.75 V.low, 0.25 Low)	1.25 (0.75 V.low, 0.25 Low)	2.25 (0.75 Low, 0.25 Average)	1.575
1.25 (0.75 V.low, 0.25 Low)	1.25 (0.75 V.low, 0.25 Low)	1.25 (0.75 V.low, 0.25 Low)	1.75 (0.25 V.low, 0.75 Low)	2.25 (0.75 Low, 0.25 Average)	1.625
1.25 (0.75 V.low, 0.25 Low)	1.25 (0.75 V.low, 0.25 Low)	1.25 (0.75 V.low, 0.25 Low)	2.75 (0.25 Low, 0.75 Average)	4.75 (0.25 High, 0.75 V. High)	2.275
1.25 (0.75 V.low, 0.25 Low)	1.75 (0.25 V.low, 0.75 Low)	1.25 (0.75 V.low, 0.25 Low)	3.25 (0.75 Average, 0.25 High)	3.75 (0.25 Average, 0.75 High)	2.275
1.25 (0.75 V.low, 0.25 Low)	1.75 (0.25 V.low, 0.75 Low)	3.25 (0.75 Average, 0.25 High)	2.75 (0.25 Low, 0.75 Average)	4.75 (0.25 High, 0.75 V. High)	2.725
2.25 (0.75 Low, 0.25 Average)	2.75 (0.25 Low, 0.75 Average)	3.25 (0.75 Average, 0.25 High)	1.75 (0.25 V.low, 0.75 Low)	4.75 (0.25 High, 0.75 V. High)	2.925
3.25 (0.75 Average, 0.25 High)	4.75 (0.25 High, 0.75 V. High)	1.25 (0.75 V.low, 0.25 Low)	2.75 (0.25 Low, 0.75 Average)	4.75 (0.25 High, 0.75 V. High)	3.325
4.75 (0.25 High, 0.75 V. High)	4.75 (0.25 High, 0.75 V. High)	4.75 (0.25 High, 0.75 V. High)	4.75 (0.25 High, 0.75 V. High)	4.75 (0.25 High, 0.75 V. High)	4.62

Table 2. Normalized data base

Sample of the normalized training data base (32768 points)					
Frequency of sub event 1	Frequency of sub event 2	Frequency of sub event 3	Frequency of sub event 4	Frequency of sub event 5	Overall frequency
0.0625	0.0625	0.0625	0.0625	0.0625	0.09375
0.0625	0.0625	0.0625	0.0625	0.1875	0.10625
0.0625	0.0625	0.0625	0.0625	0.3125	0.14375
0.0625	0.0625	0.0625	0.1875	0.3125	0.15625
0.0625	0.0625	0.0625	0.4375	0.9375	0.31875
0.0625	0.1875	0.0625	0.5625	0.6875	0.31875
0.0625	0.1875	0.5625	0.4375	0.9375	0.43125
0.3125	0.4375	0.5625	0.1875	0.9375	0.48125
0.5625	0.9375	0.0625	0.4375	0.9375	0.58125
0.9375	0.9375	0.9375	0.9375	0.9375	0.905

## 6. Conclusions

The choice to use a new drug, biological product, or medical device involves balancing the benefits and risks of the product. There are many different approaches to medical risk assessment such as classical models based on possibility and probability and calculation of risk results from the product of frequency and severity. Fuzzy logic as a new approach to risk analysis is presented as one of the best ways to deal with all the types of risk assessment including lack of knowledge. In this paper, a fuzzy logic interface is applied for a systematic risk assessment on a simple fault tree. This shows how fuzzy logic could be applied to the aim of risk assessment. The fuzzy sets could be optimized based on the obtained results.

## Acknowledgement

The authors would like to thank all the people contribute in this project.

## Corresponding Author:

Ameneh Langari  
North Khorasan University of Medical Sciences  
Bojnurd, Iran  
E-mail: [amenehlangari@yahoo.com](mailto:amenehlangari@yahoo.com)

## References

1. Emarah D A, Hussein M M., Mousa H M, Akl A Y. The Application of Fuzzy Modeling to Hazard Assessment for Reinforced Concrete Building Structures Due to Pipeline Failure Life Science Journal, 2011;8(4): 595-608
2. Hanafy T O S. Design and validation of Real Time Neuro Fuzzy Controller for stabilization of Pendulum-Cart System; Life Science Journal, 2011; 8(1): 52-60.
3. <http://www.security-risk-analysis.com>
4. Ramadan A M, El-Garhy A M, Amer F Z, Hefnawi M M. Forecasting gamma radiation levels using digital image processing; Life Science Journal, 2012; 9(1): 701-710.
5. Report to the FDA commissioner, managing the risks from medical product use creating a risk management framework, U.S. Department of health and human services, Food and drug administration; 1999.
6. Zadeh L A. Fuzzy algorithms; Information and Control 1968; 12: 94-102.
7. Zadeh L A. Fuzzy Sets; Information and Control 1965; 8:338-353.
8. Zadeh L A. Making computers think like people; IEEE Spectrum 1984; 8: 26-32.
9. Zadeh L A. Outline of A New Approach to the Analysis of of Complex Systems and Decision Processes; IEEE transaction on systems, man, and cybernetics 1973; 3(1): 28-44.

8/2/2012

## Role of Magnesium ion in neonatal jaundice

Abdel hakeem Abdel mohsen<sup>1</sup>, Mohammed F Afify<sup>1</sup>, Emad Allam<sup>2</sup> and Hedaya Abdelkarem<sup>1</sup>

Departments of <sup>1</sup>Pediatrics and <sup>2</sup>Clinical Pathology, Faculty of Medicine, El-Minia University, Egypt  
[aboueyad1@yahoo.com](mailto:aboueyad1@yahoo.com)

**Abstract:** Magnesium is found almost entirely in the intracellular compartment. The small serum component gives a poor representation of the active, physiologic state of the metal. This state is assessed much better by measuring ionized magnesium in the serum, This study was undertaken to investigate the plasma levels of ionized Mg in neonatal nonhemolytic hyperbilirubinemia by comparing the newborns with and without significant hyperbilirubinemia, Forty full term neonates their gestational ages ranged from 37 to 42 weeks were presented with jaundice(study group) and another 40 full term neonates without jaundice (control group ) were included in the study both groups were subjected to complete clinical examination , laboratory investigations, CBC ,serum calcium ,phosphorus , serum bilirubin and ionized Magnesium . The results showed that Serum bilirubin was significantly higher in study group compared to control group ( $P$  value  $<0.001$ ). Also Serum ionized Mg was significantly higher in study group compared to control group ( $P$  value = 0.04). Positive correlation between the mean serum bilirubin and the plasma ionized Mg levels .Conclusion; increase in plasma IMg may be due to extracellular movement of Mg, a principally intracellular ion, resulting from generalized cellular injury including neurons and erythrocytes. This increase has neuroprotective role against emerging toxicity risk of increasing serum bilirubin levels.

[Abdel hakeem Abdel mohsen, Mohammed F Afify, Emad Allam and Hedaya Abdelkarem. **Role of Magnesium ion in neonatal jaundice.** *Life Sci J* 2012;9(3):2274-2278] (ISSN:1097-8135). <http://www.lifesciencesite.com>. 405

**Keywords:** Ionized Mg, neonatal jaundice.

### 1. Introduction

Deposition of unbound bilirubin or its acid form in the neuron membrane causes permanent neuronal injury with a distinctive regional topography throughout the CNS.(1-2) the sequence of membrane events initiated by bilirubin molecules damages all adjacent membrane-bound enzymes and receptors. However, distant plasma membrane structures such as N-methyl-d-aspartate (NMDA) receptor/ion channel complex located within neuronal membranes on the synaptic surface of neurons are disrupted as well. Increased and prolonged activation of NMDA receptor as in perinatal asphyxia and hypoxic ischemic encephalopathy (HIE) results in brain cell injury despite its physiologic roles in brain plasticity; neuronal growth; synaptogenesis; and development of learning, memory, and vision. However, it has been shown in newborn piglets that bilirubin also increases activation of the NMDA receptor by modifying its binding characteristics, increases the receptor's affinity for NMDA receptor antagonists, and thus results in neuronal injury<sup>(3)</sup>. Magnesium (Mg) ion, is one of the most important antagonistic regulators of the NMDA receptor/ion channel complex (8-,9). It protects the CNS against hypoxia and exerts its neuroprotective effects by blocking excitotoxic and NMDA receptor-mediated neuronal injury mechanisms<sup>(10-11)</sup>. Many physiologic functions of Mg ions seem to act against or compensate for the neurotoxic effects of bilirubin molecules<sup>(12, 13)</sup>. Plasma levels of ionized Mg (IMg), which is thought to reflect the metabolic status of the

physiologically active fraction of Mg truly and accurately<sup>(14)</sup>, and its relationship to serum bilirubin levels in neonatal hyperbilirubinemia have not been investigated previously. In this study, we aimed to investigate the plasma levels of IMg in neonatal nonhemolytic hyperbilirubinemia by comparing the newborns with and without significant hyperbilirubinemia.

### 2. Subjects and Methods

This a case control study was performed at Pediatrics department of El Minia University Hospital during the period from June 2011 to February 2012, forty newborns were presented with jaundice, they were full-term, appropriate-for-gestational-age, and healthy newborns were enrolled in the study. Also another 40 healthy full term matched neonates without jaundice was taken as control group Newborns that had cephalohematoma, any congenital malformation, inborn errors of metabolism, or proven sepsis or infection or whose mother was antenatally administered Mg sulfate at any time during gestation were not included. Newborns with anemia or with hemolytic hyperbilirubinemia were excluded from the study. Written informed consent was obtained from the parents of the patients and controls

Both study group and control group were subjected to the followings:

1-History taking: Birth weight, mode of delivery, sex, gestational age, Apgar score, and postnatal age of the cases were recorded , Antenatal medications, Maternal illness, day of onset of jaundice, Frequency of breast

feeding, time of initiation of breast feeding, Symptoms suggesting neonatal infection (poor suckling, fever, diminished activity), and bleeding anywhere

2-Physical examination: Complete systematic examination for all cases was done with stress on: Weight, Length, Head circumference, Site of jaundice (head and neck, upper trunk, lower trunk, thigh, palms, soles), pallor. Organomegally (hepatosplenomegally, lymphadenopathy) bleeding and associated congenital anomalies

3-Laboratory investigations:

Under complete aseptic conditions, a venous blood sample was taken during the period (3<sup>rd</sup> to 5<sup>th</sup> day) of age from each subject and used for the determination of the followings: Complete blood count (CBC), using Sysmex KX-21 N, Japan, Serum ca level, serum phosphorus level, Liver function tests (SGOT, SGPT), Blood urea nitrogen and serum creatinine levels, CRP (C- reactive protein), using semi quantitative latex agglutination test, Serum bilirubin levels

Plasma ionized magnesium levels; was measured spectrophotometrically using ready for use kit supplied by QUIMICA CLINICA APLICADA S.A. company-Spain.

#### Statistical Methods:

After collection of data, they were added and entered into a personal computer. Analysis of the data was done using SPSS (Statistical Package for the Social Sciences). The following statistical tests were used:

1. Mean and standard deviation (SD) to describe quantitative data.

2. Student t test was used to compare between two groups as regards parametric data.
3. Chi-square test was used to compare between two groups as regards non-parametric data.
4. Pearson correlation was used to correlate two quantitative variables.

For all tests, a probability (*p*) of less than 0.05 was considered significant.

Graphical presentation of the results was also done.

#### 3. Results

Results of the study are presented in the following tables and figure.

Table (1) shows clinicolaboratory characteristics of the studied groups. There was no significant difference between both groups as regard, sex distribution, gestational age, Apgar score and mode of delivery. In Group I: 19 of the newborn babies had jaundice in head and neck (mild jaundice) and 21 newborns had jaundice in head, neck and upper trunk (moderate jaundice), Cases with severe jaundice were excluded from the study.

Also there was no significant difference between the two groups as regard, white blood cells count, hemoglobin level, platelets count, reticulocytic count, C-reactive protein, renal function, serum calcium and phosphorus

Table (2); Serum bilirubin was significantly higher in group (I), (*P* value <0.001).and Serum ionized Mg was significantly higher in group I (*P* value = 0.043). The mean  $\pm$  SD of plasma ionized Mg was (0.54  $\pm$  0.06 mmol/L) in group (I) compared to (0.50  $\pm$  0.06 mmol/L) in group (II).

**Table (1): Clinical and laboratory manifestations of the studied groups**

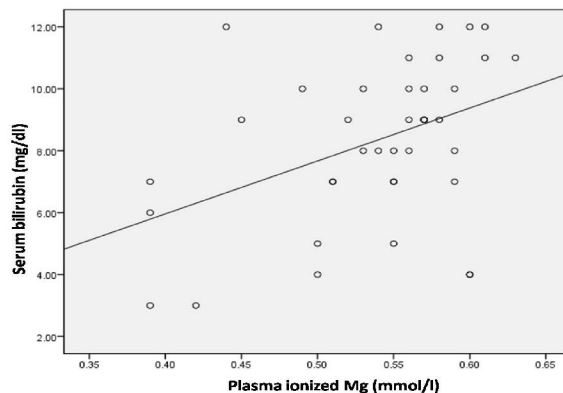
Datum	Group I (Hyperbilirubinemia) (n=40)	Group II (Control) (n=40)	P value
Sex			
Female	21 (52.5%)	12 (60%)	0.69
Male	19 (47.5%)	8 (40%)	0.42
Mode of delivery			
Vaginal	24 (60%)	13 (65%)	0.67
Cesarean	16 (40%)	7 (35%)	0.21
Gestational age (weeks)	39.8 $\pm$ 1.4	39.85 $\pm$ 1.38	0.57
Age of onset of jaundice (days)	4.1 $\pm$ 0.9	----	----
Site of jaundice			
Head and neck	19 (47.5%)	-----	-----
Head, neck & Upper trunk	21 (52.5%)	-----	-----
WBCs $\times 10^3$ /mm <sup>3</sup>	6.9 $\pm$ 1.8	7.1 $\pm$ 2.2	0.69
Haemoglobin (gm/dl)	14.6 $\pm$ 2.48	14.9 $\pm$ 3.3	0.67
Platelets $\times 10^3$ /mm <sup>3</sup>	296 $\pm$ 54	310 $\pm$ 74	0.42
C-reactive protein	Negative	Negative	NS
SGOT (I.U./l)	45 $\pm$ 17	47 $\pm$ 21	0.57
SGPT (I.U./l)	34 $\pm$ 13	31 $\pm$ 15	0.52
Blood urea (mg/dl)	12 $\pm$ 1.2	11 $\pm$ 2.3	0.46
Serum creatinine (mg/dl)	0.49 $\pm$ 0.13	0.48 $\pm$ 0.10	0.54
Serum calcium (mg/dl)	8.87 $\pm$ 0.65	8.55 $\pm$ 0.73	0.26
Serum phosphorus (mg/dl)	5.4 $\pm$ 1	5.6 $\pm$ 0.8	0.59

**Table (2) Serum bilirubin and plasma ionized magnesium**

Parameters	Group I (study) (n=40)	Group II (Control) (n=40)	P value
Serum bilirubin (mg/dl)	8.3 $\pm$ 2.6	0.62 $\pm$ 0.17	<0.001**
Plasma ionized magnesium (mmol/l)	0.54 $\pm$ 0.06	0.5 $\pm$ 0.067	0.04*

\*=Significant

\*\* Highly significant



**Figure (1): Correlation between plasma ionized Mg and serum bilirubin level**

It shows the positive correlation between the mean serum bilirubin and the plasma ionized Mg levels in the newborns included in our study (group 1).

#### 4. Discussion

The exposure of astrocytes to UCB (unconjugated bilirubin) decreases the uptake of glutamate and thus prolongs the presence of glutamate in the synaptic cleft<sup>(15)</sup>. This leads to overstimulation of NMDA receptors (excitotoxicity), both *in vitro* (developing rat brain neurons) and *in vivo* (the jaundiced Gunn rat)<sup>(16-17)</sup>. Although the blocking and modulating effects of Mg ions on NMDA receptor/ion channel complex have been well demonstrated<sup>(18)</sup> and its neuroprotective effects in the pathophysiology of HIE (hypoxic ischemic encephalopathy) have been investigated<sup>(19-21)</sup>, the relationship between Mg and neonatal hyperbilirubinemia has not been investigated in details.

Measurement of ionized magnesium (IMg) provides an accurate assessment of the free form of Mg, which is the physiologically active form and is most reflective of the biologically active and not easily measurable intracellular Mg fraction<sup>(22)</sup>.

The aim of the study was to evaluate the plasma level of ionized Mg and correlate it with serum bilirubin level in neonatal jaundice. Sixty full term neonates included in the study and classified into two groups: **Group I (study group)**: included 40 full term newborn infants with neonatal jaundice (21 females and 19 males) and their gestational age ranges from 37 to 42 weeks. Apart from neonatal jaundice they were clinically free; no evidence of sepsis, hemolysis or inborn error of metabolism. **Group II (control)**: included 20 full term healthy neonates without jaundice cross matched with age and sex (12 females and 8 males), their gestational age ranges from 37 to 42 weeks.

The study revealed no significant difference between both groups as regard sex, mode of delivery, gestational age and Apgar score. Also there was no significant difference between the two groups as regard, white blood cells count, hemoglobin level, platelets count,

reticulocytic count, C-reactive protein, renal function, serum calcium and phosphorus

There was a significant difference as regard jaundice in group I compared to group II, because in **group I**, 19 of the newborn babies had jaundice in head and neck (mild jaundice) and 21 newborns have jaundice in head and neck & upper trunk (moderate jaundice)<sup>(23-24)</sup>. In this study we found that there was a significant increase in serum bilirubin in **group 1** compared to **group 2** ( $p < .0001$ ).

Also the study showed that plasma ionized Mg level was significantly higher in **group 1** compared to **group 2** ( $P=0.03$ ). The increased Mg level may be due to mild hemolysis not detectable by the ordinary investigations. Also the increase in Mg level may be due to extracellular movement of intracellular Mg because of cellular injury by high bilirubin level that may cause neuronal and generalized cellular injury **Sarici et al.**<sup>(24)</sup>. These results are in agreement with **Misra et al.**<sup>(25)</sup> who reported increased serum Mg in neonatal physiological jaundice and also in agreement with **Huseyin et al.**<sup>(26)</sup> who found higher serum Mg and manganese in newborn infant with physiological jaundice and their mothers compared to newborn without jaundice.

Different from our results are **Tuncer et al.**<sup>(27)</sup> as they reported that lower serum total mg concentrations in both umbilical cord and maternal blood of newborns with hyperbilirubinemia when compared with normal newborns, and they postulated that hypomagnesemia results from intracellular shift of Mg ions.

In their next study, **Tuncer et al.**<sup>(28)</sup> investigated the serum levels of zinc, copper and total mg in umbilical cord blood and peripheral venous blood of newborns with nonhemolytic hyperbilirubinemia and they reported lower umbilical and neonatal serum zinc and total mg concentrations in both newborns with moderate hyperbilirubinemia and

newborns with severe hyperbilirubinemia undergoing exchange transfusion in comparison with newborns without hyperbilirubinemia. They speculated that maternal gestational malnutrition may have caused maternal and neonatal hypomagnesemia by negatively affecting enzymes in bilirubin metabolism and antioxidant enzyme in erythrocytes, thus leading to significant neonatal indirect hyperbilirubinemia.

The differences in Mg levels (decreased versus increased) between these two studies and our study may be due to either the differences in the method used or to the differences in serum bilirubin levels and ages of the newborns among these studies. Also the differences may be due to that in our study we measured ionized Mg.

In another study, **Pintov et al. (29)** investigated the value of umbilical cord zinc, copper and total Mg measurements in predicting the future (48<sup>th</sup> hour) development of hyperbilirubinemia and they reported no differences in the levels of these trace elements and Mg between 29 newborns with a serum bilirubin level of  $\geq 136.8 \mu\text{M}$  (mean,  $186.4 \pm 41 \mu\text{M}$ ) and 61 newborns with a serum bilirubin level of  $\leq 136.8 \mu\text{M}$  (mean,  $106 \pm 17.1 \mu\text{M}$ ) at the 48<sup>th</sup> hour of life. They regarded the measurement of these elements in cord blood of no value in predicting the development of significant hyperbilirubinemia. However, the mean serum bilirubin levels in that study were in the range of physiologic hyperbilirubinemia, and these serum bilirubin levels may not be high enough to reveal the relationship between Mg and hyperbilirubinemia.

In this study we found that there was no correlation between plasma ionized Mg level and gestational age, these results was not in agreement with **Mehta and Petrova, (30)** as they found that plasma ionized magnesium level varies with gestational age this may because we include in the study full term neonates but their study include preterm neonates. In our study we found that there was a significant positive correlation between serum bilirubin level and ionized Mg level (correlation coefficient,  $r = 0.27$  &  $p = 0.01$ ). This finding suggests the possibility of a neuroprotective role or a compensatory mechanism in plasma ionized Mg increase against emerging toxicity risk of increasing serum bilirubin values. These results are in agreement with **Sarici et al. (24)** who found a positive correlation between ionized Mg and the severity of hyperbilirubinemia in full term newborns with neonatal jaundice.

Supporting our suggestion regarding the neuroprotective role of magnesium, **Gathwala et al. (20)** in an earlier study, had reported that a dose of 250 mg/kg and 125 mg/kg of magnesium sulfate given as an infusion is safe and well tolerated by asphyxiated neonates. He found that EEG abnormalities occurred in 43.75% of the cases in the control group.

Also **Bhat et al. (19)** in a recent study concluded that postnatal magnesium sulfate treatment improves neurologic outcomes at discharge for term neonates with severe perinatal asphyxia. On the other side, **Broner et al. (31)** in a study performed on pediatric intensive care patients, concluded that hypermagnesemia and hypocalcaemia were both associated with poor outcome as measured by either survival or length of ICU stay.

## 5. Conclusion

In conclusion, presence of significantly higher plasma IMg levels in newborns with hyperbilirubinemia suggest that increase in plasma IMg may be due to extracellular movement of Mg, resulting from generalized cellular injury including neurons and erythrocytes., we also may conclude the possibility of a neuroprotective role or a compensatory mechanism of increased IMg levels to reduce bilirubin toxicity. And to question the future value of Mg treatment in the therapy of neonatal hyperbilirubinemia.

## Acknowledgement

To all members of neonatal care unit at Al Minia university Hospital and department of clinical pathology for their help to complete this work.

## References

1. Volpe JJ., 1995: Bilirubin and brain injury. In: Volpe JJ (ed) Neonatal Neurology. WB Saunders, Philadelphia, 490–514.
2. Brodersen R., 1979: Bilirubin solubility and interaction with albumin and phospholipid. J Biol Chem., 254:2364–2369 |
3. Cashore WJ., 1998: Bilirubin metabolism and toxicity in the newborn. In: Polin RA, Fox WW (eds) Fetal and Neonatal Physiology. WB Saunders, Philadelphia, 1493–1498.
4. Hoffman DJ, Zanelli SA, Kubin J, Mishra OP, Delivoria-Papadopoulos M., 1996: The *in vivo* effect of bilirubin on the N-methyl-D-aspartate receptor/ion channel complex in the brains of newborn piglets. Pediatr Res., 40:804–808 |
5. McDonald JW, Shapiro SM, Silverstein FS, Johnston MV., 1990: Excitatory amino acid neurotransmitter systems contribute to the pathophysiology of bilirubin encephalopathy. Ann Neurol., 28:413A(abstr).
6. Hoffman DJ, McGowan JE, Marro P, Mishra OP, Delivoria-Papadopoulos M., 1994: Hypoxia-induced modification of the N-methyl-D-aspartate (NMDA) receptor in the brain of newborn piglets. Neurosci Lett., 167:156–160.
7. Johnston M, McDonald M, Chen C, Trescher W., 1991: Role of excitatory amino acid receptors in perinatal hypoxic-ischemic brain injury. In:



- Meldrum BS, Moroni F, Simon RP, Woods JH (eds) Excitatory Amino Acids. Raven Press, New York, 711–716.
8. Ascher P, Nowak L., 1987: Electrophysiological studies on NMDA receptors. *Trends Neurosci.*, 10:284–288
  9. Hoffman DJ, Marro PJ, McGowan JE, Mishra OP, Delivoria-Papadopoulos M., 1994: Protective effect of MgSO<sub>4</sub> infusion on NMDA receptor binding characteristics during cerebral cortical hypoxia in the newborn piglet. *Brain Res.*, 644:144–149
  10. Thordstein M, Bagenholm R, Thiringer K, Kjellmer I., 1993 :Scavengers of free oxygen radicals in combination with magnesium ameliorate perinatal hypoxic-ischemic brain damage in the rat. *Pediatr Res.*, 34:23–26
  11. Aikawa JK., 1981: Magnesium: its biological significance. CRC Press, Boca Raton, 21–56.
  12. Brierly GP, Jung DW, Altschuld RA., 1987: Magnesium and mitochondrial ion transport. In: Altura BM, Durlach J, Seelig MS (eds) Magnesium in Cellular Processes and Medicine. Karger, Basel, 89–105.
  13. Altura BM., 1994: Introduction: importance of Mg in physiology and medicine and the need for ion selective electrodes. *Scand J Clin Lab Invest Suppl.*, 217:5–9.
  14. Silva R, Mata LR, Gulbenkian S, Brito MA, Tiribelli C, *et al.*, 1999. Inhibition of glutamate uptake by unconjugated bilirubin in cultured cortical rat astrocytes: role of concentration and pH. *Biochem Biophys Res Commun*; 265:67–72
  15. Grojean S, Lievre V, Koziel V, Vert P, Daval JL., 2001: Bilirubin exerts additional toxic effects in hypoxic cultured neurons from the developing rat brain by the recruitment of glutamate neurotoxicity. *Pediatr. Res.* 49:507–13.
  16. McDonald JW; Shapiro SM; Silverstein FS; *et al.*, 1998: Role of glutamate receptor-mediated excitotoxicity in bilirubin-induced brain injury in the Gunn rat model. *Experimental Neurology*; 150:21-29.
  17. Eby GA and Eby KL, 2006: Rapid recovery from major depression using magnesium treatment. *Medical hypotheses*; 67:362-70.
  18. Gathwala G, Khera A, Singh I., 2006: Magnesium therapy in Birth Asphyxia. *Indian J Pediatr*; 73:209–12.
  19. Bhat MA, Charoo BA, Bhat JI *et al.*, 2009: Magnesium sulphate in severe perinatal asphyxia: A randomized placebo controlled trial. *Pediatrics*; 123:764–69.
  20. Gathwala G, Khera A, Singh J, *et al.*, 2010: Magnesium for neuroprotection in birth asphyxia. *J Pediatr Neurosci*; 5:102-4.
  21. Cook LA and Mimouni FB, 1997: Whole blood ionized magnesium in the healthy neonate. *J Am Coll Nutr*; 16:181-83.
  22. Kramer LI., 1969: Advancement of Dermal Icterus in the Jaundiced Newborn. *Amer J Dis Child* ;118: 454-458.
  23. Kumral A, Ozkan H, Duman N, *et al.*, 2009: Breast milk jaundice correlates with high levels of epidermal growth factor. *Pediatr Res.*, 66:218–21.
  24. Sarici SU, Serdar MA, Erdem G, *et al.*, 2004: Evaluation of plasma Ionized Magnesium Levels in neonatal Hyperbilirubinemia. *Pediatr Res*; 55:243-47.
  25. Misra PK, Kapoor RK, Dixit S, *et al.*, 1988: Trace metals in neonatal hyperbilirubinemia. *Indian J Pediatr*; 25:761-64.
  26. Hassan TB, Jagger C, Barnett DB, 2002: A randomised trial to investigate the efficacy of magnesium sulphate for refractory ventricular fibrillation. *Emerg Med J*; 19:57-62.
  27. Tuncer M, Yenice A, Ozand P, 1972: serum Mg, Ca, total protein levels in maternal and cord blood and its clinical significance. *Turk Jpediatr* 14:13-22.
  28. Tuncer M, Demirsoy S, Özsoylu Ş, *et al.*, 1982: The significance of zinc, copper, and magnesium levels of maternal, cord and newborns' sera in hyperbilirubinemia of unknown etiology. *Turk J Pediatr*; 24:227-33
  29. Pintov S, kohelet D, Arbel E, *et al.*, 1992): predictive inability of cord zinc, magnesium and copper levels on the development of benign hyperbilirubinemia in the newborn. *Acta paediatr*; 81:868-69.
  30. Mehta R and Petrova A, 2007: ionized magnesium and gestational age, *Indian J Pediatr*; 74(11):1025-8.
  31. Broner CW, Stidham GL, Westenkirchner DF, *et al.*, 1990: hypermagnesemia and hypocalcemia as predictors of high mortality in critically ill pediatric patients. *Crit Care Med*; 18:921.