

# CONTENTS

44	<b>Cancer Diagnosis Using Data Mining Technology</b> Muhammad Shahbaz, Muhammad Shaheen, Syed Ather Masood	308-313
45	<b>Integrated Data Mining Framework For Natural Resource Exploration</b> Muhammad Shaheen, Muhammad Shahbaz, Syed Muhammad Ahsan, Syed Athar Masood	314-316
46	<b>Transformational Leadership and Attribution Theory: The Situational Strength Perspective.</b> Syed Athar Masood, Muhammad Shahbaz, Muhammad Shaheen	317-329
47	<b>Potato Chips and Roasted Bread Induced Chromosomal Aberrations and Micronuclei Formation in Albino Rats</b> Ramadan A.M. Ali, Nadia H.M. Sayed and Dalia D. Abd El-Monem	330-336
48	<b>Image Denoising based on Sparse Representation and Non-Negative Matrix Factorization</b> R. M. Farouk and H. A. Khalil	337-341
49	<b>Gut Histology of Malaysian River Catfish, <i>Mystus nemurus</i> (C&amp;V) Larvae</b> Ghada Ahmed El Hag, Mohd Salleh Kamarudin, Che Roos Saad and Siti Khalijah Daud	342-347
50	<b>Epidemiology of Dysmenorrhea among Adolescent Students in Assiut City, Egypt</b> Eman M. Mohamed	348-353
51	<b>Ameliorative Effects of Sildenafil in Acetic Acid-Induced Chronic Colitis in Rats</b> Osama M. Ahmed, Alaa Afifi, Tarek M. Ali, Shimaa A. Ramadan and Ayman M. Mahmoud	354-361
52	<b>Problems of housing environment for the elderly</b> Sakeena Mohamed Abdel-Rahman Basabrain	362-366
53	<b>Factors Affecting Public Sector Investment in Agriculture in Iran: The Usage of Unrestricted Error Correction Model</b> Seyed Nemat Allah Mousavi, Azadeh Dogani and Javad Torkamani	367-373
54	<b>Effect factors on meat imports to Iran</b> Seyed Nemat Allah Mousavi, Mohammad Reza Rezaei, Seyed Mohammad Reza Akbari	374-377
55	<b>Peripheral Blood Expression of Angiotensin II type 1- Receptor (AT<sub>1</sub>- R) as A Non Invasive Marker of Liver Disease Progression in Patients with Non Alcoholic Fatty Liver Disease</b> Mohammed A Rady, Elhamy Abd Al Monem, Mona A Shafie, Maha Sabawy, Nashwa Sheble and Mona M Hassouna	378-386
56	<b>Power output and Efficiency of internal combustion engine based on the FTT theory</b> Reza Masoudi Nejad	387-390
57	<b>Relationship between Family Environment and Emotional Intelligence: Examination of the Moderating Factor</b>	391-395

	Fataneh Naghavi, Marof Redzuan	
<b>58</b>	<b>Relationships between Family Functioning, Alexithymia and Emotional Intelligence among Early Adolescents in Tehran-Iran</b> Fataneh Naghavi, Marof Redzuan	<b>396-401</b>
<b>59</b>	<b>Relationship between nitrogenous pollution of borehole waters and distances separating them from pit latrines and fertilized fields</b> Basie Vinger, Mbhuti Hlophe and Mailoo Selvaratnam.	<b>402-407</b>
<b>60</b>	<b>The study of the difference between the melamine stone induced hydronephrosis and congenital hydronephrosis in infants: clinical features and their 24-month follow-up</b> Jian Guo Wen, Yan Wang, Rui Zhang, Lu Xing, Zhenzhen Li, Qing Wei Wang, An Feng Lou, Shengjun Zhang, Jens Christian Djurhuus, Jørgen Frøkiær	<b>408-412</b>
<b>61</b>	<b>The Expression and Regulation of GSK-3<math>\beta</math>, CDK-5 and PP2A in Differentiated Neural Stem Cells of Rats</b> ZHAO Qing-xia, XU Yan, YAN Wen-hai, HAN Xue-fei, XING Ying	<b>413-418</b>
<b>62</b>	<b>Effect of Afla-Toxins B1 on Endocrine Status in Cat fish (<i>Clarius lazera</i>)</b> Mona S. Zaki and Olfat Fawzy	<b>419-422</b>
<b>63</b>	<b>MACROBUTTON MTEditEquationSection2Equation Chapter 1 Section 1 SEQ MTEqn \r \h \* MERGEFORMAT SEQ MTSec \r 1 \h \* MERGEFORMAT SEQ MTChap \r 1 \h \* MERGEFORMAT Genetic Diversity among Eight Egyptian Snakes (Squamata-Serpents: Colubridae) Using RAPD-PCR</b> Nadia H. M. Sayed	<b>423-430</b>
<b>64</b>	<b>Effect of Diabetes Mellitus on Patients Undergoing Laparoscopic Cholecystectomy: A Comparative Cross-Sectional Study</b> Saleh M. Aldaqal, Alia T. Albaghdadi, Hanaa M. Tashkandi, Basem S. El-deek, Ghada A. Al-Malki; Ali M. Turki, and Ahmed M. Makki	<b>431-439</b>
<b>65</b>	<b>Spiritual Well-Being and Mental Health among Malaysian Adolescents</b> Nurizan Yahaya, Yadollah Abolfathi Momtaz, Mumtazah Othman, Norhasmah Sulaiman, & Farhan Mat Arisah	<b>440-448</b>
<b>66</b>	<b>Evaluation of Water in Iran's Agriculture: A case study of Dashtenaz of Sari-Iran</b> Foad Eshghi, Seyyed-Ali Hosseini-Yekani	<b>449-452</b>
<b>67</b>	<b>The Muscular Function for Human Knee Movement Revealed from Electromyography: A Preliminary Study</b> Y.-P. Sun, K.-T. Yen, H.-K. Kung, Y.-C. Tsai, K.-C. Lu, C. M. Du, Y. C. Liang	<b>453-456</b>
<b>68</b>	<b>Applications of Thermal Spray Coating in Artificial Knee Joints</b> J.-C. Hsiung H.-K. Kung H.-S. Chen Kuan-Yu Chang	<b>457-463</b>

## CANCER DIAGNOSIS USING DATA MINING TECHNOLOGY

Muhammad Shahbaz<sup>1</sup>, Shoaib Faruq<sup>2</sup>, Muhammad Shaheen<sup>1</sup>, Syed Ather Masood<sup>2</sup>

<sup>1</sup>Department of Computer Science and Engineering, UET, Lahore, Pakistan  
Muhammad.Shahbaz@gmail.com, M.Shahbaz@uet.edu.pk

<sup>2</sup>Department of Engineering Management, EME College, NUST, Rawalpindi, Pakistan.  
athermasood2000@hotmail.com

**Abstract:** Cancer is a set of diseases in which some cells of the body grow abnormally. These cells then destroy other surrounding cells and their normal functions. Cancer can spread throughout the human body. Since it is a very treacherous disease its diagnosis is very important. In some forms it spreads within days. So the diagnosis of cancer at early stages is very important. The challenge is to first diagnose the main type and then its subtypes. This research uses data mining classification tools to make a decision support system to identify different types of cancer on the Genes dataset. Data mining technology helps in classifying cancer patients and this technique helps to identify potential cancer patients by simply analyzing the data.

[Muhammad Shahbaz, Shoaib Faruq, Muhammad Shaheen, Syed Ather Masood. **Cancer Diagnosis Using Data Mining Technology**. Life Science Journal. 2012;9(1):308-313] (ISSN:1097-8135). <http://www.lifesciencesite.com>.

44

**Keywords:** Data Mining; K-Nearest Neighbors; Naïve Bayesian; SVM, Classification; Cancer

### INTRODUCTION

Cancer is normally diagnosed by examining the cells using a microscope. Imaging tests like computerized tomography (CT) or mammography help in indicating the possible presence of cancer by depicting an abnormal growth or mass. Final decision is usually taken by having different kinds of lab tests of the patient and observing closely the cancer cells under study.

Another method used by Doctors is called biopsy. Biopsy is done by surgery. Doctors take a sample of the tissue that is under study. This sample is then examined with the help of a microscope. The appearance of normal cells is uniform; they are organized in order and are of equal size. Cancer cells are different than normal cells. They are in dispersed order, their sizes are different and they are not structured well.

The problem with this is that a medical image such as CT scan or MRI cannot show all the patterns and information for a particular type of cancer or subtypes of cancer. Another issue is that a doctor with his/her naked eye and a microscope cannot remember a large number of patterns of the disease.

It is frightening for a patient to know that he/she has cancer. A patient can lose all hope after being diagnosed with cancer. Therefore cancer diagnosis is a process that needs proper care and patience on both sides i.e. the patient and doctor/hospital.

Early diagnosis of cancer can help save the life of a patient because Cancer cells cause destruction to other cells and spread to other parts of body very quickly. If it is diagnosed in the early stage, the

treatment begins earlier and this can prevent further spread of the disease.

**Existing diagnosis system at cancer hospitals:** Currently cancer diagnosis system in hospitals is manual. For example when a patient is registered he/she has to go through radiology test process i.e. X-rays, CT or MRI. Radiologist gives his remarks on the test report. After this process an expert doctor reviews the X-rays/CT/MRI and gives his remarks. In some types of cancer the diagnosis is based on the final decision by the doctors e.g. breast and lung cancer, but in other types of cancer like carcinoma some other tests are also required like biopsy. In a manual system the radiologist and the doctor diagnose cancer. This process is slow as after the radiologist's review the doctor has to review also and give his/her remarks and finally tell if the cancer is present or not. The need is to automate this process to make the cancer diagnosis efficient and fast with the use of state of the art technology.

**Genes and their importance in Cancer Diagnosis:** Genes provide very valuable information which can be used to study any disease in depth. Study of genes from a cancer patient helps us diagnose cancer and differentiate between types of cancer. It also helps in separating the healthy people from the patients. Genes contains infinite patterns that cannot be recorded manually using a microscope. DNA Micro Arrays are used to study the information obtained from Genes.

**DNA Micro Arrays:** DNA microarrays are the latest form of biotechnology. These allow the measurement of genes expression values simultaneously from hundreds of genes. Some of the application areas of DNA microarrays are obtaining the genes values

from yeast in various ecological conditions and studying the gene expression values in cancer patients for different cancer types. DNA Microarrays have huge potential scientifically as they can be useful in the study of genes interactions and genes regulations. Other application areas of DNA microarrays are clinical research and pharmaceutical industry [1].

**Data Retrieval from DNA Micro Arrays:** Gene expression data is retrieved from DNA microarray through Image processing techniques. Data for a single gene consists of two intensity values of fluorescence i.e. Red and Green. These intensities represent expression level of gene in Red and Green labeled mRNA samples. Image of a microarray is scanned. This image is then processed through image processing techniques [1].

**Image Processing:** DNA microarrays are scanned using laser scanners and its output is stored as 16-bit image. Image format is in DICOM. As DICOM is a standard for storing medical images. This image is considered raw input. In order to measure the accurate transcript wealth, different image processing methods are employed [1].

The steps for processing the scanned image from a DNA Micro Array are as follows.

**Automatic Address:** To get accurate values of intensities from microarray data we need to identify the address/location of each gene point or spot. This is known as automatic addressing and it is used to assign the spot coordinates. Accurate identification of the locations of the spots is mandatory to calculate the spot intensities.

**Segmentation:** Segmentation is a technique which separates the point of interest from the background. It is used to get the actual values of gene spots and differentiate from background of the image.

**Intensity Extraction:** Intensity extraction is an important step in image processing. Measurement of the Intensities of spots, background and quality measurements are done in this step.

**Signal:** The sum of pixel intensities within a particular spot is called signal. The collective amount of cDNA hybridized at the marked DNA sequence is represented by this sum.

## PROBLEM STATEMENT AND RELATED DATA

Sample data under study is gene expression data of cancer type leukemia and it is freely available for download at [15]. The dataset consists of 72 bone marrow samples. Samples are from the acute leukemia patients. These samples are from the patients having two types of acute leukemia i.e. acute lymphocytic leukemia (ALL) and acute myelogenous leukemia (AML). First 38 samples are training samples from which first 27(From 1 to 27) cases are ALL and 11 (From 28 to 38) are AML. In these 38

samples 8 out of 27 are T-cell samples and 19 are B-cell samples. [16] The remaining 34 are test samples in which 20 are ALL and 14 AML. In ALL sample 19 are B-cell samples and 1 is T-cell sample. [17]

Each sample contains 7129 human genes expressions spotted on a DNA microarray as described above.

Data was in the form of a data file (.dat) and it was converted to comma separated values (.csv) file format using MATLAB. It was then used for further analysis using Data Mining Tool called Rapid miner. Every record had its class attribute. Class attribute was in numeric form. There were three classes

1. AML
2. ALL – B Cell
3. ALL – T Cell

In original dataset ALL – B Cell class was represented by value 0, ALL – T Cell class was represented by 1 and AML was represented by a value 2. For analysis I have changed the class attribute from numeric to character value as follows:

**Table 1: Class Label Transformation**

Class Attribute	Old Value	New Value
ALL – B Cell	0	ALL-B
ALL – T Cell	1	ALL-T
AML	2	AML

Figure 1 below shows the view of data, first column of data is class. From column 2 to 7130 are gene expression values for each sample of each DNA.

The challenge here is to find out the best classification method that help in identifying the classes present in data.

## RESULTS AND DISCUSSIONS

Below is a summary of results and performance comparison of the experiments performed above. We have performed experiments using three algorithms Naïve Bayesian, K Nearest Neighbors and SVM. For each result a confusion matrix is presented which shows the actual samples in a particular class and the predicted class. Accuracy of the classification algorithm is also given with the results.

### Results for Naïve Bayesian Algorithm:

**Table 2: Confusion Matrix for Naïve Bayesian Algorithm**

	Actual ALL-B	Actual ALL-T	Actual AML	Class Precision
Predicted ALL-B	37	4	0	90.24 %
Predicted ALL-T	0	5	0	100 %
Predicted AML	1	0	25	96.15 %

A	B	C	D	E	F	G
LeukemiaType	AFFX-BioB-5_at	AFFX-BioB-M_at	AFFX-BioB-3_at	AFFX-BioC-5_at	AFFX-BioC-3_at	AFFX-BioDn-5_at
2 ALL-B	-214	-153	-58	88	-295	-558
3 ALL-T	-139	-73	-1	283	-264	-400
4 ALL-T	-76	-49	-307	309	-376	-650
5 ALL-B	-135	-114	265	12	-419	-585
6 ALL-B	-106	-125	-76	168	-230	-284
7 ALL-T	-138	-85	215	71	-272	-558
8 ALL-B	-72	-144	238	55	-399	-551
9 ALL-B	-413	-260	7	-2	-541	-790
0 ALL-T	5	-127	106	268	-210	-535
1 ALL-T	-88	-105	42	219	-178	-246
2 ALL-T	-165	-155	-71	82	-163	-430
3 ALL-B	-67	-93	84	25	-179	-323
4 ALL-B	-92	-119	-31	173	-233	-227
5 ALL-T	-113	-147	-118	243	-127	-398
6 ALL-B	-107	-72	-126	149	-205	-284
7 ALL-B	-117	-219	-50	257	-218	-402
8 ALL-B	-476	-213	-18	301	-403	-394
9 ALL-B	-81	-150	-119	78	-152	-340
0 ALL-B	-44	-51	100	207	-146	-221
1 ALL-B	17	-229	79	218	-262	-404
2 ALL-B	-144	-199	-157	132	-151	-347

Figure 1: Dataset showing class and attribute values

JMY	JMZ	JNA	JNB	JNC	JND	JNE	JNF	
111	-125	389	-37	793	329	36	191	-37
137	-36	442	-17	782	295	11	76	-14
199	33	168	52	1138	777	41	228	-41
135	218	174	-110	627	170	-50	126	-91
149	57	504	-26	250	314	14	56	-25
221	-76	172	-74	645	341	26	193	-53
119	-178	151	-18	1140	482	10	369	-42
129	-86	302	23	1799	446	59	781	20
180	6	177	-12	758	385	115	244	-39
186	26	101	21	570	359	9	171	7
142	32	137	-81	672	208	25	116	-62
124	60	194	-10	291	41	8	-2	-80
183	3	530	-39	696	302	24	74	-11
140	52	229	-4	431	269	8	163	-22
122	20	332	-5	195	59	31	116	-18
131	-26	455	-62	736	445	42	246	-43
115	127	255	50	1701	1109	61	526	-83
173	-57	694	-19	636	205	17	127	-13
197	-48	1939	-18	538	90	-50	333	-24
120	-110	209	-51	1435	255	53	545	-16
195	-12	36	26	208	113	-8	22	-22
102	57	253	-52	1010	405	19	270	-27
158	140	176	-22	617	336	9	243	36
125	13	249	1	646	391	81	203	-94

Figure 2: Showing the last columns of data

As described earlier leukemia data set has three classes ALL-B, ALL-T and AML. First column in the matrix represents the predicted class and subsequent columns represent the actual number of

occurrences in each class. If we look at column 2 of row 2 it shows the value 37. It means that there were actually 37 samples of class ALL-B in our data and they are classified by Naïve Bayesian algorithm

correctly. Now we move on to row 2 and column 3 it shows a value 4. It means that these 4 samples are incorrectly classified. In last column of row 2 there is a 0 value which means that there are no samples which are incorrectly classified as AML. To see the correctly classified instances we must see values in diagonal i.e. 37, 5 and 25. It means that there are 5 samples incorrectly classified represented by row 2 column 3 with value 4 and row 4 column 2 with value 1. We can calculate the accuracy of the algorithm by simple method that there are total 72 samples and 5 fall to an incorrect class so the accuracy of classification is 95% approximately.

Last column in confusion matrix shows the precision of each predicted class. Precision for class ALL-B is 90.24 %, for ALL-T is 100 % and for AML it is 96.15% for Naïve Bayesian classifier.

### Results for K Nearest Neighbor Algorithm:

**Table 3: Confusion Matrix for K Nearest Neighbor Algorithm**

	Actual ALL-B	Actual ALL-T	Actual AML	Class Precision
Predicted ALL-B	38	2	5	84.44 %
Predicted ALL-T	0	7	0	100 %
Predicted AML	0	0	20	100 %

As described previously leukemia data set have three classes ALL-B, ALL-T and AML. First column in the matrix represents the predicted class and subsequent columns represent the actual number of occurrences in each class. According to K Nearest neighbor algorithm there are 38 instances in row 2 and column 2 that are classified correctly. In next column of row two the value is 2 that depicts that there are 2 samples which are incorrectly classified as ALL-T. In column 3 of row 2 value of 5 shows that there are 5 samples incorrectly falling in AML category/class. For ALL-T if we look at diagonal values that is row 3 and column 3, 7 instances are correctly classified by KNN algorithm. There are 20 instances which are correctly classified as AML in last row and last column. Accuracy for this algorithm can be calculated by subtracting the incorrectly classified instances. We have 72 samples, out of which 7 are incorrectly classified by KNN so we have accuracy value 90.72% for this method.

Class precision is shown in the last column of the confusion matrix for predicted classes. Precision for class ALL-B is 84.44 %, for ALL-T is 100 % and for AML it is 100% for K Nearest Neighbor Classifier.

### Results for SVM Algorithm:

**Table 4: Confusion Matrix for SVM learning algorithm**

	Actual ALL-B	Actual ALL-T	Actual AML	Class Precision
Predicted ALL-B	38	4	3	84.44 %
Predicted ALL-T	0	5	0	100 %
Predicted AML	0	0	22	100 %

For SVM Classification method we have one value in confusion matrix at row 2 and column 3 which is 4 this is incorrectly classified by SVM. Another value incorrectly classified is at row 2 column 4 it has value 3. There are 7 samples which are incorrectly classified by SVM. Accuracy for this method is 90.27%.

Class precision is shown in the last column of the confusion matrix for predicted classes. Precision for class ALL-B is 84.44 %, for ALL-T is 100 % and for AML it is 100% for SVM classification algorithm.

### CONCLUSION

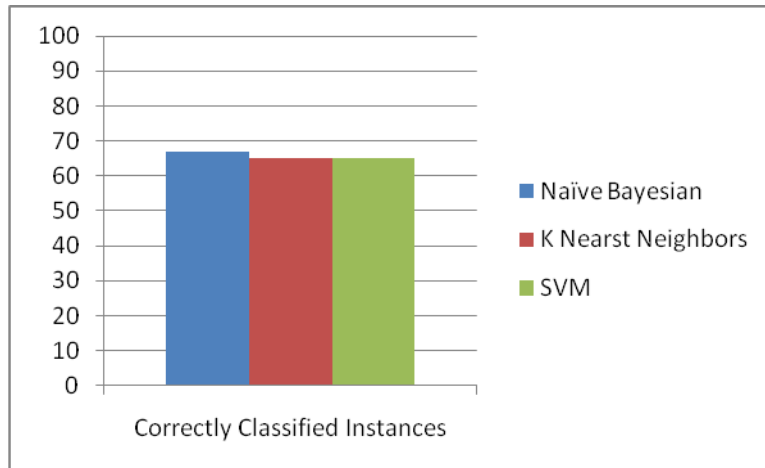
According to results above Naïve Bayesian Classification has the most accurate prediction for leukemia dataset samples. Naïve Bayesian classified 95% of the samples correctly in their respective classes. It has only error rate of 5%. Naïve Bayesian is the best method for classifying DNA Microarray genes expression data.

Figure 3 represents the comparison of the three algorithms and their correctly classified samples / instances. Similarly Figure 4 depicts the number of incorrectly classified instances.

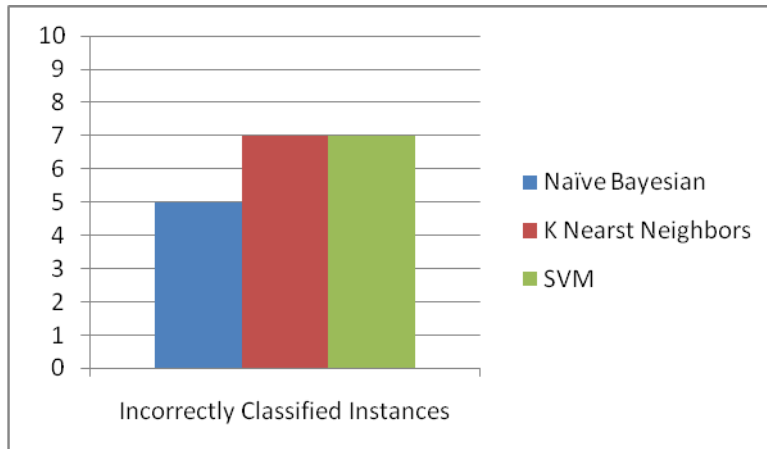
Accuracy for different algorithms is shown in figure 5 i.e. Naïve Bayesian, K Nearest Neighbors and SVM.

### SUGGESTIONS AND FUTURE WORK

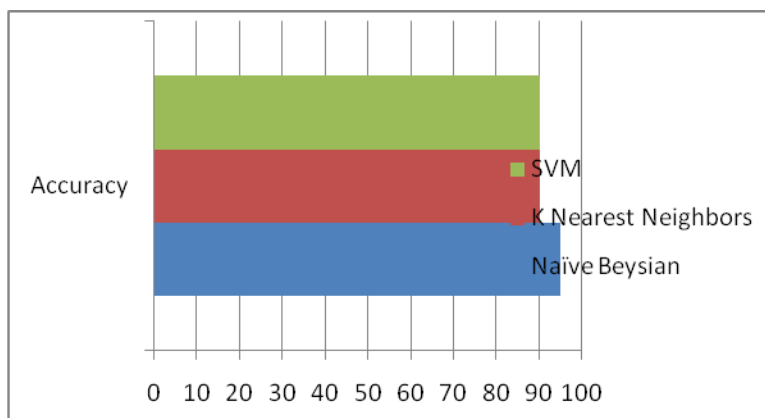
The results above can be improved by reducing the number of attributes we have in the dataset. This can be done using dimensionality reduction techniques like principle component analysis. Problem with principle component analysis is that we do not have the track of data which is considered redundant by this method. If we can somehow obtain the pattern of data that is redundant and get information about which attributes or values are retained then it would be a great improvement in the classification results of any of the learning algorithm.



**Figure 3: Correctly classified instance by each learning algorithm**



**Figure 4: Incorrectly classified instance by each learning algorithm**



**Figure 5: Accuracy for each learning algorithm**

**REFERENCES**

- [1]. Statistical methods for identifying differentially expressed genes in replicated cDNA microarray experiments.
- [2]. <http://www.cancer.gov/cancertopics/what-is-cancer>.
- [3]. Cancer Research UK (January 2007). UK cancer incidence statistics by age. Retrieved on 2007-06-25.
- [4]. WHO (February 2006). Cancer. World Health Organization. Retrieved on 2007-06-25.
- [5]. American Cancer Society (December 2007). Report sees 7.6 million global 2007 cancer deaths. Reuters. Retrieved on 2007-12-17.
- [6]. Duerinckx AJ, Pisa EJ. Filmless Picture Archiving and Communication System (PACS) in Diagnostic Radiology. Proc SPIE 1982;318;9-18. Reprinted in IEEE Computer Society Proceedings of PACS'82, order No 388.
- [7]. Introduction to Data Mining and Knowledge Discovery, Third Edition ISBN: 1-892095-02-5.
- [8]. Principles of Data Mining. Max Bramer, BSc, PhD, CEng, FBCS, FIEE, FRSA, Digital Professor of Information Technology, University of Portsmouth, UK. ISBN-10: 1-84628-765-0.
- [9]. Quinlan, J. R., Induction of Decision Trees. Machine Learning, 1986. 1(1): pp. 81-106.
- [10]. Tutorial: Introduction to Belief Networks, Teknomo, Kardi. K-Nearest Neighbors Tutorial. <http://people.revoledu.com/kardi/tutorial/KNN/>
- [11]. A Tutorial on Support Vector Machines for Pattern Recognition, CHRISTOPHER J.C. BURGESS, Bell Laboratories, Lucent Technologies Gene Expression Profiling based Multi-Class Cancer Classification using AdaBoost and Artificial Neural Network, Gwangju Institute of Science and Technology (GIST)
- [12]. Gwangju, Republic of Korea. Classification and diagnostic prediction of cancers using gene, expression profiling and artificial neural networks, JAVED KHAN, JUN S. WEI, MARKUS RINGNÉR, LAO H. SAAL, MARC LADANY, FRANK WESTERMANN, FRANK BERTHOLD, MANFRED SCHWAB, CRISTINA R. ANTONESCU, CARSTEN PETERSON & PAUL S. MELTZER. Nature Publishing Group <http://medicine.nature.com>

1/19/2012



**INTEGRATED DATA MINING FRAMEWORK FOR NATURAL RESOURCE EXPLORATION**Muhammad Shaheen<sup>1</sup>, Muhammad Shahbaz<sup>1</sup>, Syed Muhammad Ahsan<sup>1</sup>, Syed Athar Masood<sup>2</sup><sup>1</sup>Department of Computer Science and Engineering, UET, Lahore, Pakistan  
shaheentanoli@gmail.com<sup>2</sup>Department of Engineering Management, EME College, NUST, Rawalpindi, Pakistan.  
athermasood2000@hotmail.com

**Abstract:** The study is aimed at developing spatio temporal data mining framework for natural resource exploration. A framework will be said as spatio temporal if it deals with changes in space over time. The study revealed different applications of existing and newly proposed spatio temporal data mining techniques on huge databases collected from diverse sources. The work is integrated on the basis of different proposed Techniques in a unified framework which could serve as a basic skeleton for hydrocarbon prospecton.

[Muhammad Shaheen], Muhammad Shahbaz, Syed Muhammad Ahsan, Syed Athar Masood. **Integrated Data Mining Framework for Natural Resource Exploration.** Life Science Journal. 2012;9(1):314-316] (ISSN:1097-8135). <http://www.lifesciencesite.com>. 45

**Keywords:** Data Mining; Classification; Hydrocarbon, Clustering, Decision Tree

**INTRODUCTION**

Hydrocarbon exploration takes place by following a dedicated procedure which utilizes specialized resources and resource persons. The presence of a hydrocarbon reserve beneath earth's surface needs a great deal of time, cost and expertise. The techniques used to predict hydrocarbon reserves starts from surface manifestations, proceeds through detailed magnetic, seismic and geological surveys and ends at predicting a wildcat which can either be a huge reserve or an empty reservoir in extreme considerations.

The use of data mining is not limited to hydrocarbon exploration; it has also produced some promising results in reservoir characterization, well logging, and in the calculation of various attributes such as shear-wave velocity [5]. With the exception of the expert's knowledge in geological survey, hydrocarbon exploration does not usually use mathematical models; rather, it is an interpretive science that requires a highly accurate prediction about the presence of hydrocarbons prior to digging into the Earth and mining. The limited diffusion of data mining in this area can be attributed to the lack of complete understanding, because of its emergence, of the knowledge discovery model, which spans across the steps of exploration, as well as the need to apply it to multi-natured data collected from diverse sources [7].

Hydrocarbon is found in natural gas, crude oil, bitumen, gasoline, petroleum, natural gas liquids, liquefied natural gas, and fluids. The earliest sediments of oil and gas were deposited into the Earth about 560 million years ago. The oil and gas

industry has been evolving since the 19th century, when geological survey was the sole means by which to prospect oil and gas. However, the 19th and 20th century brought technological innovation which has since been used in exploration. Subsequently, correlating the prediction of known reservoirs with expected reservoirs became standard for geologists and explorers [2] and additional development in exploration techniques improved geologists' understanding of exploration. Despite this improvement, the exploration of hydrocarbons continues to be a risky endeavor which takes, on average, three to six years and costs millions of dollars [4].

The paper is organized in a systematic way. Section 2 will state the preliminaries of proposed framework. Section 3 will exhibit and discuss the final framework. Section 4 will conclude the work.

**PROJECT DESCRIPTION**

This project has been directed to provide a framework which utilizes intelligent data mining techniques on history data in order to reduce enormous cost and time. The project is basically divided in two parts;

1. Pre-prospection activities
2. Prospection activities

First part deals with identifying critical dimensions that are conclusive for hydrocarbon exploration and consumption. In this part, we have classified world nations w.r.t. sustainable hydrocarbon development.

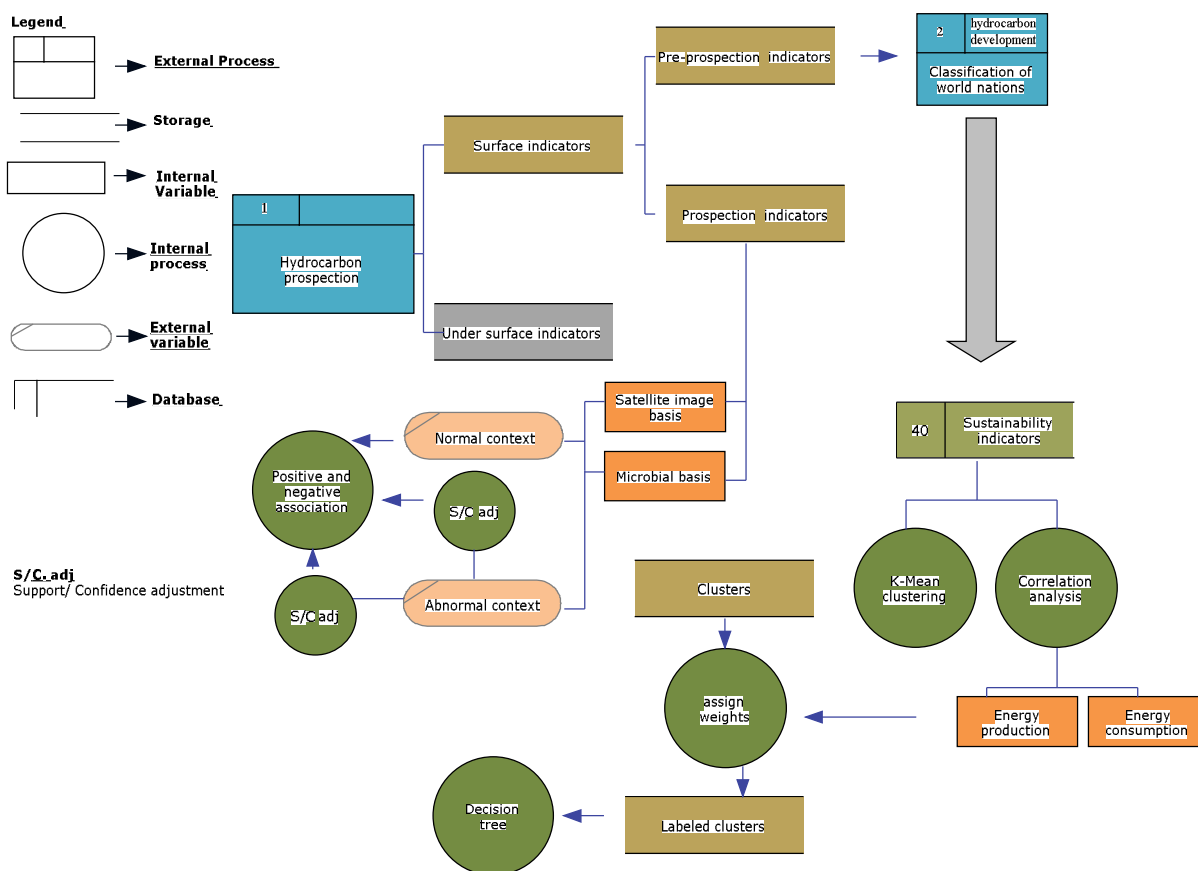


Figure 1 – Integrated Spatio Temporal Data Mining Framework for Natural Resource Exploration

We have then identified the dimensions on critical path. For this purpose, sustainability indicators are mined by proposing two innovative extensions in unsupervised classification methodology. Once the hydrocarbon development standing of a nation is identified, an optimal hydrocarbon prospecting method may be proposed to fulfill consumption needs. In the proposed framework, the prospecting is solely based upon data mining of current/ history data [6].

In existing scenario, hydrocarbon prospecting involves some typical earth engineering, mining and geological techniques. Data mining and its minion domains has the potential to be utilized on such data repositories. A successful application will obviously cut down the cost and time and it will also reduce the need of expertise. The data sources used in prospecting at current can be divided into 1. Surface indicators. 2. Under surface indicators. Surface indicators are initial manifestations for site drilling. In our study surface indicators are only considered to be included in spatio temporal data mining framework. In the detailed study only two data sources have been focused upon. 1. Remotely sensed satellite images. 2. Microbial data. These two data

sources are changing the convention for initial decision. The dependency of initial decision of drilling a wildcat should remain on the patterns extracted from remotely sensed satellite image and microbial data.

The detailed literature survey of supervised and unsupervised classification techniques revealed that the use of association rule mining on both of these data sources will produce the best [3]. The reason is twofold;

1. The classification techniques divide datasets in multiple groups where each is tagged by a class label. Hydrocarbon prospecting is not about dividing the data into classes but to predict a value based on the fact that conditions are provided.
2. The decisions about hydrocarbon prospecting are rule based. Its equivalent modeling in computer science is IF-THEN-ELSE rules which can be obtained by using association rule mining.

Prospecting based on remotely sensed satellite image and microbial data is done by using association rule mining. In existing applications, association rule mining is used to mine positive rules

from databases only. Based on existing technique for positive and negative association rule mining, the rules are extracted from remotely sensed image whereas only positive association rules are taken from microbial data. Context is state of object, entity and environment and is not considered in mining association rules whereas it enormous effect on accuracy of association rules. For association rule mining the general Apriori algorithm [1] is being used all on spatial, non-spatial and spatio temporal data. We have proposed a new context based positive and negative association rule mining algorithm which is applied to remotely sensed and microbial data to predict a hydrocarbon reserve on the basis of associations among objects in satellite images and relationships among microbial indicators.

### PROPOSED FRAMEWORK

In the figure 1, the complete framework for hydrocarbon exploration project is given. First, it is established that hydrocarbon exploration activity can be done with the help of surface and sub surface indicators. Sub surface indicators are not considered in this activity because of higher cost and manpower involved in it. Surface indicators are utilized both for pre-prospection and prospection tasks. In pre-prospection phase world nations are classified into five clusters which are labeled then in order to rank hydrocarbon development of that particular nation. In order to label clusters the sustainability indicators are correlated with energy consumption and production. These labeled clusters are then mapped on to a decision tree for supporting decision makers in identifying weak dimensions of hydrocarbon development. Once the decision tree is drawn, the prospection may be preceded. Prospection indicators can be elicited from various sources including geological attributes, microbial attributes and well logs. In the proposed framework only two data sources are considered in prospection phase from which maximum required data can be elicited. Context based association rule mining is applied both on remotely sensed and microbial data in different contextual situations. The support-confidence adjustments are being made according to the algorithm proposed in section 4.5.

The methodologies proposed for the above framework are used for hydrocarbon prospection but can also be used in other applications. The technique for labeling clusters is generic in nature and can be applied upon any dataset clusters. Similarly context variables and its integration in positive/negative association rule mining can be utilized on datasets which have the potential to reflect different patterns in different contextual situations [6].

### CONCLUSION

In this paper, an integrated spatio temporal data mining framework is developed as a decision support system for hydrocarbon prospecting. The work is composed of diverse flavors because of following two reasons; The conventional process of hydrocarbon prospecting use data from diverse sources to make a prediction about hydrocarbon reserve. The proposed framework is aimed to utilize analytical techniques of data mining in the conventional hydrocarbon exploration framework. Since the data is from diverse sources, the intelligent techniques can better be utilized if the application of technique is considered in data source perspective. That is why; different techniques are utilized in all three phases. The practiced algorithms of data mining in its crude form might not be that much suitable to be applied for predicting type of energy development and preparing hydrocarbon prospecting plan. For this, new algorithms and extensions in existing algorithms are proposed. Since these algorithms are from diverse classes hence the framework for hydrocarbon exploration seems to be diverse which infact leads to single unified goal i.e. hydrocarbon prospecting.

### ACKNOWLEDGEMENTS

The project is undertaken at Department of Computer Science & Engineering, University of Engineering & Technology Lahore, Pakistan. The data is collected from industrial sector of Pakistan.

### REFERENCES

1. Agarwal, R., Srikant, R., 1994. Fast Algorithms for Mining Association Rules., Proceedings of the 20<sup>th</sup> VLDB Conference, Chile., Pp. 487-499.
2. Bott, R.D., 2004 .Evolution of Canada's Oil and Gas Industry. Canadian Center for Energy Information.
3. Han, J., Kamber, M., 2001. Data Mining: Concepts and Techniques. Morgan Kaufmann, New York. 550 pp. 284-291.
4. Jahn, F., Cook, M., Graham, M., 2003. Hydrocarbon Exploration and Production. Elsevier Science B.V. 9 - 15.
5. Justice, J.H., Hawkins, D.J., Wong, G., 1985 . Multidimensional Attribute Analysis and Pattern Recognition for Seismic Interpretation. Pattern Recognition. 18, 391-407.
6. Shaheen, M., Shahbaz, M., Guergachi, A., Rehman, Z., 2011. Mining Sustainability Indicators to classify Hydrocarbon Development., Elsevier Knowledge-based Systems., Vol. 24, No.8, pp. 1159-1168.
7. Shaheen, M., Shahbaz, M., Guergachi, A., Rehman, Z., 2010. Data Mining Applications in Hydrocarbon Exploration., Springer Artificial Intelligence Review., Vol. 35, No.1, pp. 1 – 18.

1/12/2012

## Transformational Leadership and Attribution Theory: The Situational Strength Perspective.

Syed Athar Masood<sup>1</sup>, Muhammad Shahbaz<sup>2</sup>, Muhammad Shaheen<sup>3</sup>

<sup>1</sup>Department of Engineering Management, EME College, NUST, Rawalpindi, Pakistan.

[athermasood2000@hotmail.com](mailto:athermasood2000@hotmail.com)

<sup>2,3</sup>Department of Computer Science and Engineering, University of Engineering and Technology, Lahore, Pakistan

[Muhammad.Shahbaz@gmail.com](mailto:Muhammad.Shahbaz@gmail.com), [M.Shahbaz@uet.edu.pk](mailto:M.Shahbaz@uet.edu.pk), [Shaheen@uet.edu.pk](mailto:Shaheen@uet.edu.pk)

**Abstract:** The objectives of this study were to study transformational leaders behaviour in manufacturing organisations with respect to situational strength and attribution theory. The methodology employed for this research was the “Concurrent nested strategy”, a mixed method approach. The mixed approach included a quantitative stage as the first phase for this study. This stage utilised a questionnaire based on the transformational leadership questionnaire developed by Podsakoff, et. al.[1], which segregated a sample of transformational leaders and qualitative interviews. The qualitative interviews were conducted to obtain an insight into the concepts of situational strength and attribution made by manufacturing leaders for the causes of poor performance. The second phase of the research involved a questionnaire using Likert *scale ranging from 1 to 5*. Results from the research show that transformational leaders tends to make weak situational strength to their followers and tend to make external attributions for the causes of poor performance in their organisations, and assume that follower’s mistake as a learning experience.

[Syed Athar Masood], Muhammad Shahbaz, Muhammad Shaheen. **Transformational Leadership and Attribution Theory**. Life Science Journal. 2012;9(1):317-329] (ISSN:1097-8135). <http://www.lifesciencesite.com>. 46

**Key Words:** Transformational leadership, manufacturing organisations, situational strength, attribution theory.

### 1. Introduction

The style of the leader is considered to be particularly important in achieving organizational goals, with research consistently demonstrating the benefits of transformational leadership style over the more traditional forms, such as transactional leadership style, in terms of achieving organizational goals (Awamleh 1999; Conger 1999, Dubinsky and Yammarino 1995). The leader's style is also considered important in being able to evoke performance among followers (Barling 1996, Zacharatos and Berson 2000).

Transformational leadership is believed to be one of the demanding requirements for industries in the present era. Transformational leadership has become a necessity in the post-industrial world of work [4]. It has been specified as an important mechanism for introducing organisational change and has received substantial research attention over the last two decades. It, however, has also generated several conceptual issues, such as the need for more knowledge about the relationship of transformational leadership with business contextual issues, as several researchers noted [5], [6] that, transformational leadership research is at a stage where its conceptual examination is important.

### 2. Research Context

The challenges faced by the organisations have become increasingly complex because business and other organisations are changing their structures, reducing layers of management control, and striving to become more agile and responsive to their environments. The results of these ongoing transformations are that there is a pervasive need for people at every level to participate in the leadership process. No single leader can possibly have all the answer to every problem, especially if those problems are in the form of new challenges, those problems for which an organisation has no pre-existing resources, tools, solutions, or sense-making strategies for accurately naming and describing the challenge, Heifetz (1994). Consequently all organisational members need to be leaders and all leaders need to be better prepared to participate in leadership.

Burns (1978) noted the level of mediocrity or degree of irresponsibility of many in the positions of industrial leadership. According to him, we fail to grasp the essence of leadership that is relevant to the modern age. Leaders in today’s organisations are continuing to face competitive forces. In addition, the impact of trying to keep up with the fast pace of technological change, combined with serious technical work-force shortages and never knowing when an external force is going to make a bid for a company that is vulnerable, are just a few of the

problems today's industrial leaders must face on a daily basis, Scarborough (2001).

Manufacturing is the most difficult and demanding fields. It is also the most critical part of industry as well as, the most critical to a country's economy, and demands the highest skills of its leaders. According to Woodgate (1991, p-xii) manufacturing problems appear to be much more a matter of leadership than of technology. There has been cases, where companies have gone from poor to excellent and from red to black due to either excellence in leadership and vice versa. The search for and identification of behaviours that increase a leader's effectiveness, has been a major concern for practicing managers and leadership researchers alike for the past several decades [7-13]. Traditional views of leadership effectiveness have focused primarily, although not exclusively, on what Burns [14] and Bass [15] have called transactional leader behaviours. According to Burns[14], transactional behaviours are founded on an exchange process where the leader provides rewards in return for the follower's effort. The leadership behaviour research found that the strongest determinant of follower's satisfaction with the leader is considerate-supportive behaviour. Favourable leader-follower relations are much more likely for leaders who act friendly, open, sympathetic, and helpful towards followers feeling, and do things to advance their follower's careers [16, pp.275]. More recently, however, the focus of leadership research has shifted from one examining the effects of transactional leadership to the identification and examination of those behaviours exhibited by the leader that make followers more aware of importance and values of task outcomes, activate their higher-order needs, and induce them to transcend self-interests for the sake of the organization [12,13,15]. These transformational or charismatic behaviours are believed to augment the impact of transactional leader behaviours on employee outcome variables, because "followers feel trust and respect toward the leader and they are motivated to do more than they are expected to do" [13, pp. 272]. Transformational leaders provide vision and direction to the organisation, and are able to energise and inspire other members of the organisation in the pursuit of organisational objectives. Other researchers who focus on the same concepts are House, [18], Bass, [15]; Bennis & Nanus, [19]; Tichy & DeVanna, [20], Bass, Avolio, & Goodheim, [21]; Bass. Waldman, Avolio, & Bebb, [22]; Conger & Kanungo, [23]; Boal & Bryson, [24]; House, Woycke, & Fodor, [25]; Avolio & Bass, [26]; Shamir, House, & Arthur, [27], House, Spangler & Woycke, [28]; and Howell & Frost, [29]. However the approaches of these researchers differs somewhat in the specific

behaviours they associate with transformational leadership, although all of them focus on the same perspective that effective leaders transform or change the basic values, beliefs, and attitudes of followers so that they are willing to perform beyond the minimum levels specified by the organisation. The empirical results, for example, Bass [15] cites a variety of field studies demonstrating that transformational leader behaviours are positively related to employees' satisfaction, self-reported effort, and job performance, that have verified the impact of transformational behaviours on employee attitudes, effort, and "in-role" performance.

### 3. Situational Strength

Situations impose particular requirements for effective leadership, and relative importance of different behaviours depends on the situation [12]. By 'situation' in situational leadership theory, [37] it means: the willingness and ability of people to do their work assignments, , the nature of the work they do, and the climate of the organisation. Fiedler's [38,39] Least Preferred Co-worker (LPC) contingency model describes how the situation moderates the relationship between leader traits and effectiveness. The relationship between leader LPC score and effectiveness depends on a complex set of situational variables called situational favourability variables (or situational control). Fiedler defines favourability as the extent to which the situation gives a leader control over followers. Favourability is measured in terms of leader-member relations, position-power, and task structure, i.e., relations with followers are friendly or otherwise, the leader has the authority to administer rewards and punishments, and standard operating procedures to accomplish the task, a detail description of the finished product is available or not.

The concept of situation strength has been used to study the effect of various concepts of leadership behaviour, some of these focused on variables such as: perceived managerial discretion, (Carpenter, Golden, [40] relation between personality and contextual performance, (Beaty, Cleveland, Murphy, [41] role of individuals in initiating proactive change (Mullins, & Cummings,[42]), environmental uncertainty [(Carpenter, Fredrickson,[43], Sutcliffe, Huber,[44]. Another stream of research deals with the personality of the leader and the organizational strategy that the leader prefers to implement (Wright Peter & Parnell [45]). The situational strength concept by Mischel [46] is defined in terms of a strong and a weak situation. A strong situation can be conceived as a red traffic light where behaviour is generally controlled by the situation – everybody stops at the red light

irrespective of his or her personality. A strong situation can result from technological constraints and rules (like the traffic light) or be a system of tight regulation of behaviour (target measures and standard operating procedures) or where a team exerts powerful group norms, for example in a manufacturing context, the implementation of a lean manufacturing system. An amber light is rather more ambiguous – whether to go or whether to stop – and an individual's personality can influence behaviour. This is an example of weaker situational strength, for e.g. in a manufacturing context, the implementation of flatter organizations and agile systems providing employees with more opportunities for participative decision making [47] (Dani, Burns, Backhouse, 2003). The Trait approach defines the situation as, how people behave in novel, ambiguous, or what is called “weak” situations. Situations that are governed by clearly specified rules, demands, or organisational policies are called “strong” situations. It is also likely that the type of employee in the strong situation company will have adapted to that strong situation and will not challenge the system. This is not true of the weak situation where the individual is probably more used to, and accepting of, ambiguity and a lack of a strong company policy, and is likely to deliver an individual response akin to their own ways of behaving in the particular situation. Leaders and followers should understand that the situation strength is not set in concrete, they can change the situation for people to be more satisfied and productive (Hughes, Ginnett, & Curphy, [48,pp.347]. An essential element of good leadership is not only the direction of followers, but their personal development as well. Coaching and guidance become more important than direct targeted supervision as the follower becomes more capable.

The leader's success in moving a follower toward greater autonomy and intrinsic motivation depends on the leader's ability to recognize the form of supervision needed at a particular time in the follower's development and the follower's readiness for graduation to the next level.

Solid empirical evidence (e.g., Green & Mitchell, 1979; Mitchell & Wood, 1980) suggests that judgments of a follower's capabilities, needs, and personality follow the logic of attribution theory (Jones & Davis, 1965; Kelley, 1967). Leaders try to act as “naive scientists,” assessing the follower's current and past work behaviour, comparing it to that of others in the group or organization, and arriving at a course of action based on judgments of the role of internal and external factors in performance. Further research is required to explore the attribution dynamic that constructs charisma, and to explore the limits of charisma in leadership.

In short, success enhances the perception of leadership, while failure limits perceptions of leadership. Causal ascriptions to leaders are a basic part of this process. As traditional attribution theory implies (Kelley 1973), if people are seen as being more causal in determining favourable outcomes, then the perception that they are leaders is enhanced; if they are seen as being less causal for good performance, their leadership ratings are not as high. Causal attributions are also crucial in explaining observers' interpretations of poor performance. Sutton and Callahan (1987) point out that filing for bankruptcy under Chapter 11 of the Federal Bankruptcy Code stigmatizes both the organization and its management. One tactic for managing such stigmatization is for leaders to deny responsibility for poor organizational performance by attributing causality to the environment. Although this tactic often proves difficult to implement because top managers are expected to exercise control over their organizations and such control is expected to produce organizational success (Sutton and Callahan 1987, 406).

### **3. Attribution Theory:**

As it was pointed by Levine & Moreland (1990) that attribution was most active as an area of organisational behaviour research in the 1980s, and the importance of the role of attribution theory in organisational settings was further emphasised in Martinko (1995a). Recently, there has been a resurgence of research based on attribution theory. A further unexplored area that is the beginning to attract attention is the role of attribution in motivation, Martinko (1995b); Weiner, (2000).

Some leadership theories, seek to clarify the construct of leadership by examining what leadership consists of (e.g., traits, behaviours). Others are more concerned with the process of leadership; that is, how leaders decide what action to take and the impact of those actions on others (e.g., the path-goal model). This distinction is applicable to the attribution leadership research. For example, one line of research has demonstrated how descriptions of leader behaviour are affected by such factors as knowledge of group performance (Butterfield, Powell, & Mainiero, 1978; Farris & Lim, 1969; Lord, Binning, Rush, & Thomas, 1978; Mitchell, Larson, & Green, 1977; Rush, Thomas, & Lord, 1977). A second line of attribution research, rather than attempting to tap these implicit leadership theories, seeks to determine their effects on the leadership process. At the forefront of this line of inquiry is a two-step attributional model of leadership proposed by Green and Mitchell (1979). This model suggests that leaders, given evidence of follower performance, infer the cause of the performance (i.e., make

attributions) prior to determining the appropriate action to take. This model has evoked a series of direct empirical tests (Green & Liden, 1980; Ilgen, Mitchell, & Fredrickson, 1981; Mitchell & Kalb, 1981; Knowlton & Mitchell, 1980; McFillen & New, 1979; Mitchell & Wood, 1980; Mitchell & Liden, 1982; Mitchell, Green, & Wood, 1981; Wood & Mitchell, 1981).

Attribution theory describes how individuals develop causal explanations for behaviours and outcomes, and how their causal explanations influence subsequent reactions (Martinko, 1995). Although there are many variations of attribution theory, research on attributions has primarily focused on two conceptual approaches; (1) achievement motivation models (e.g., Weiner, 1986) which emphasize how individuals explain their own successes and failures; and (2) observer models (e.g., Kelley, 1973) which emphasize how individuals explain the behaviours and outcomes of others.

The attributional leadership model also posits that leaders evaluate follower behaviours by using classification schema such as the classical two-dimensional model of Weiner et al. (1972). The Weiner model is composed of (1) a locus of control dimension which delineates whether the primary cause of the behaviour is a characteristic of the follower (an internal attribute) or a characteristic of the situation (an external attribute); and (2) a stability dimension which delineates whether or not the follower's behaviour is likely to remain constant (stable) or change over time (unstable). The crossing of the locus of control and stability dimensions produces a 2 by 2 matrix of four causal factors that a leader can utilize to explain a follower's behaviour: stable/internal (ability); stable/external (task difficulty); unstable/external (luck/chance); unstable/internal (effort).

As a leader determines the causal factor(s) for a follower's performance, the ascribed attributions influence both the leader's expectations for future performance and his or her behaviour toward the follower. Leaders are more likely to take corrective action toward the situation when performance problems are attributed primarily to external causal factors. In contrast, leaders are more likely to take corrective action toward the follower when a performance problem is primarily attributed to internal factors (Mitchell & Wood, 1980). In addition, corrective action is more likely to be punitive in nature when the leader attributes poor performance to a lack of effort, as compared to a lack of ability.

Attribution theory suggests that we observe the behaviour of others and then attribute causes to it. Initially put forward by Heider (1958), attribution

theory focuses on the inferences that are used to deduce someone else's disposition or traits, from observations of their behaviour. It has the advantages and disadvantages of being tied to a relatively small number of core theoretical statements (Heider 1958, Jones & Davis 1965, Kelly 1967). Central to Heider's theory is the proposal that people see behaviour as being caused either by the individual in question (i.e. dispositional), or by the environment (situational). It makes a distinction between internal and external causes - that is, whether people initiate actions themselves, or purely react to the environment in which the action takes place

The question is: how do we decide what type of attribution to make? Kelley's Co-variation Model (1967) extends the work of Heider and attempts to explain exactly how we make judgements about internal and external causes. The principle of co-variation states that an effect is attributed to one of its possible causes, with which over time, it co-varies' (Kelley, 1967). That is to say that if two events repeatedly occur together, we are more likely to infer that they are causally related than if they very rarely occur together. Kelley's model suggests that if the behaviour to be explained is thought of as an effect of something, which has occurred, the cause can be one of three kinds. The extent to which the behaviour co-varies with each of these three kinds of possible cause is what we actually base our attribution upon. Fischhoff (1976) has noted, psychologists - especially those interested in attribution theory should read some philosophy. Many, perhaps most, of us lack a training in the conceptual analysis that characterizes philosophy, but we can benefit from the attention philosophers have devoted to such questions as what is 'behaviour' (Dretske, 1988), what is an 'event' (Pachter, 1974), what is a 'disposition' (Rozeboom, 1973) or, what is a 'cause'? It is, to say the least, ironic that an idea so fundamental to attribution theory - the concept of causality - has received so little attention in the social-psychological literature (Shaver, 1981).

The classic approach is that of David Hume, his prototypical example of causality was one billiard ball striking another - the collision is followed by movement of the previously stationary ball, but is not seen as producing it. Many definitions of cause are to be found in Hume's work, but perhaps the clearest is the following:

A cause is said to be an object followed by another, and where all the objects similar to the first are followed by objects similar to the second, where, if the first object had not been, the second had not existed. (Hume, 1748/1975, pp. 76-7)

Hume's causality is typically referred to as 'constant conjunction' (e.g., Ayer, 1980, p. 68), and

the definition above certainly conveys the meaning of covariation between cause and effect, which is fundamental to Kelley's (1967) theory of causal attribution.

John Stuart Mill's (1872/1973) conception of cause has significantly influenced attribution theory, via Kelley's (1967) theory. Mill wrote that the cause is the sum total of the conditions positive and negative taken together which being realized, the consequent invariably follows' (quoted by Davidson, 1967, p. 692). As Davidson noted, is whether the true cause must include all the antecedent conditions that were jointly sufficient for the effect. Mill argued that what people ordinarily call the cause is one of these conditions, arbitrarily selected, which becomes inaccurately labelled 'the cause'. To distinguish between the cause and mere conditions Hart and Honore use two factors or contrasts, these are the contrasts between what is abnormal in relation to any given subject-matter and between a free deliberate human action and all other conditions' (1956/1961, p. 332). For example, what is the cause of a railway accident would assume until corrected that the train was moving at normal speed, carrying a normal weight, that the driver stopped and started, accelerated and slowed down at normal times. To mention these normal conditions would obviously provide no explanation of the disaster, for they are also present when no disaster occurs; whereas the mention of bent rail does provide an explanation. Accordingly, though all the conditions mentioned are equally necessary, the bent rail is the cause and the others are mere conditions. It is the bent rail we say which 'made the difference' between disaster and normal functioning. (Hart and Honore, 1956/1961, p. 334).

If a leader attributes a follower's poor performance to internal factors such as low effort or a lack of ability, he or she may reprimand, dismiss, or provide training for the employee concerned. If, however, poor performance is attributed to external factors such as a lack of material, or to work overload, the leader would need to concentrate on these factors and improve the situation instead of giving negative feedback to the employee.

As a leader determines the causal factor(s) for a follower's performance, the ascribed attributions influence both the leader's expectations for future performance and his or her behaviour toward the follower. Leaders are more likely to take corrective action toward the situation when performance problems are attributed primarily to external causal factors. In contrast, leaders are more likely to take corrective action toward the follower when a performance problem is primarily attributed to internal factors (Mitchell & Wood, 1980). In

addition, corrective action is more likely to be punitive in nature when the leader attributes poor performance to a lack of effort, as compared to a lack of ability.

Research shows that people do have a strong tendency to attribute others' actions to internal, dispositional factors when evidence to the contrary is lacking (Shackleton, 1995).

Leaders attribute to the causes of poor performance defined by the researcher in terms of manufacturing organisations are defined as either internal or external attributions. Internal attributions include follower's lack of interest, inexperienced followers, absenteeism by followers, or any other cause due to follower's side. External causes include, poor performance mainly due to machines break down, tool break down, material inventory problem, material quality problem, or any other cause by external factors, which are beyond control of followers.

##### **5. Research Methodology**

Data was analysed using the mixed methods integration concurrent nested strategy by Creswel [59]. According to Creswel, integration of the two types of data (qualitative and quantitative) might occur at several stages in the process of research, the data collection, the data analysis, interpretation, or some combination of places. The concurrent nested model may be used to serve a variety of purposes. Often, this model is used so that a researcher can gain broader perspectives as a result of using the different methods as opposed to using one predominant method alone. This research studies the behaviour of transformational leaders in manufacturing organisations with respect to situational strength, and attribution made by leaders. It was necessary to have a sample of transformational leaders and then probe further into the aspects of situational strength, and attribution. The concurrent nested strategy thus provided a method for integrating quantitative and qualitative research methodologies by using the quantitative method for generating the sample of transformational leaders and the qualitative method to study the aspects of situational strength, and attribution. Data collection was started from the bottom level of the organisation structure, i.e., from shop floor worker by using Podsakoff's transformational leadership questionnaire for rating their leaders about transformational leadership characteristics. Questionnaire was translated into Urdu language, which is the Pakistan national language for understandable by lower-level hierarchy followers. Once all the questionnaires were returned back by the followers, the questionnaires were analysed and leaders were categorised on the basis of transformational leadership characteristics rated by



their followers. Leaders were interviewed about their ideas of situational strength and attribution they made about the causes of poor performance.

Data Collection and analysis was done in two phases. In the first phase, the leaders were interviewed regarding the research questions, leaders responses were noted on contact summary sheets as described by Miles and Huberman (1984) and analysed using the technique of interview analysis by Fink, (2003). For further confirmation/in-depth clarification of the data collected in the first phase, a questionnaire was designed regarding research questions. The same leaders were approached again for a secondary data collection as phase-II, to respond on the questionnaire by rating their choice on a Likert scale ranging from 1 to 5, i.e., where 1=strongly disagree to 5=strongly agree. The data was analysed using the technique of the quantitative data analysis procedure described by Fink, (2003). The duration between phase-I, primary data, and phase-II, secondary data was eight months to escape the problems of practice effect, i.e., to confirm the original response of phase-I.

#### **6. Data Analysis**

The sample selected for this research were a total of 254 followers consisting of leader-follower dyads at middle and lower levels of management for 50 leaders from five manufacturing organisations in Pakistan in phase-I. Transformational leadership characteristics were measured using the 23-item questionnaire based on the measures of transformational leadership utilised by [1] for their research on transformational leadership. The measure includes six transformational leadership behaviours: articulating a vision, providing an appropriate model, fostering the acceptance of group goals, high performance expectations, individualized support, and intellectual stimulation. A 7-point scale ranging from 1=strongly disagree to 7=strongly agree was used. All the 254 respondents completed the questionnaire in phase-I. The responses were then clustered for each of the 50 leaders and the mean calculated. All the leaders, receiving a mean score greater than 4 were termed to have transformational characteristics more than the rest of the sample. Out of 50 leaders the test identified 23 leaders as being transformational in behaviour. The range of the mean scores for transformational leaders ranged from 4.49 to 5.31 out of 7. The sample of 23 transformational leaders were then interviewed to get an insight into the behaviour of transformational leaders with respect to the situational strength in their respective organisations, and attribution they made about the causes of poor performance. The interviews were recorded using "Contact Summary Sheet" procedure for data representation as explained by Miles and

Huberman (1984). The interviews were conducted in a semi-structured format, with the researcher first explaining to the respondent the concept of situational strength and then asking some questions on the aspects of discretion given to followers in decision-making and the procedures the followers had to follow in the organisation to get their job done. The followers of the respective sample of transformational leaders were also asked questions about discretion they received for taking decisions and working. This exercise improved the validity of the results by comparing the data from the leaders and their followers. The data represented in the "Contact Summary Sheets" was then coded into themes, which represented the variables of situation strength viz. discretion given to the followers and working procedures for followers.

#### **7. Discussion**

As mentioned earlier, from a sample of 50 leaders, 23 leaders had the scores termed as transformational. When these leaders were interviewed to get more information about their organisations and their insights into the situational strength of their organisations, it was noticed that 21 out of 23 transformational leaders, believed in giving some form of discretion to their followers to take decisions. According to the leaders they created a weak situation for their followers, even if the situational strength of the organisation was strong. Hence, even though the organisation had set out rules and regulations for the employees to follow and the shop floor had been provided with drawings and process sheets, the leaders had given the followers discretion to deviate from the standard processes if it helped them to complete the job. The leaders said that they were more concerned with the end results than with the processes implemented to achieve the results. The amount of discretion given differed for each leader.

When comparing these results with the views of the sample of 10 leaders who have shown the most non-transformational behaviour it is evident that non-transformational leaders prefer to work in strong situations and create strong situation for their followers without giving them any discretion.

In phase-II of data analysis and from the comparison of responses for all the organisations, it was observed that, all types of leaders (leaders with low, high or normal transformational leadership characteristics) prefer to have strict working discipline among the followers. They had clear standards on praise and punishment. The response range was from 3.50 to 4.29, which is a more positive response of the question, since a score more than 3 shows a positive response to a question whereas a

score less than 3 shows a negative responses to the question by the respondents.

Most of the leaders defined the situation in their organisation as strong as noted by the responses to question (operating a highly structured and disciplined system); the response range was from 3.49 to 3.84.

In order to determine the amount of discretion leaders favour for their followers, it was observed that; leaders with a low score on the transformational leadership scale, set more clearer goals for their followers i.e., 3.44 on the scale ranging from 1 to 5. While, leaders with high score on the transformational leadership scale, set less clear goals for their followers, i.e., 2.74. Leaders with a low score on the transformational leadership scale, prefer to make decision themselves as 3.31 on the scale, whereas, leaders with high or normal score on the transformational leadership scale delegate decision making to followers as the overall average score was less as 2.42.

Leaders with a low score on the transformational leadership scale, closely monitor their followers as the overall average score is 3.27 on the scale, whereas, leaders with high or normal score on the transformational leadership scale give more freedom to followers as the overall average score is less as 2.36.

The study thus showed that, transformational leaders created a weak situation for their followers even if the organisational situational strength was strong.

To look into behaviours of transformational leaders and the attributions they made about the causes of poor performance in manufacturing organisations, data was collected from the leaders of five manufacturing organisations used in the sample.

In phase-I of qualitative data analysis, from a sample of 50 leaders, 23 leaders had the scores to be termed as transformational on the basis of Podsakoff et al (1990) questionnaire. When these leaders were interviewed to get information about the causes of poor performance, it was observed that 18 out of 23 transformational leaders, attributed the causes of poor performance to external factors, i.e., material supply problems, material quality problems, excessive tool break downs, or power failures.

According to the leaders, their followers were hard working and took interest in performing their jobs, but due to unforeseen circumstances, for example, machines break down or material problems, sometimes they have to face poor performance. These leaders said that most of the times causes of poor performance were due to material quality problems, material inventory problems, and machines break downs.

In phase-I of the qualitative data analysis, 30% of the leaders with high transformational leadership characteristics, attributed the causes of poor performance either to the follower's lack of interest in performing their jobs, or due to inexperienced followers (internal attribution). Whereas 80% leaders with low transformational leadership characteristics attributed the causes of poor performance either due to followers, lack of interest in performing their jobs, or due to inexperienced followers (internal attribution). However 50% leaders with high transformational leadership characteristics and 58% with normal leadership characteristics attributed causes of poor performance either to machines break down or tool break down (external attribution) and only 10% leaders with low transformational leadership characteristics attributed the causes of poor performance to either machines break down or tool break downs (external attribution). With respect to the nature of the jobs of low transformational leaders, they were mostly shop floor leaders concerning manufacturing operations or assembly operations, and leaders with high transformational leadership characteristics were mostly from higher management hierarchy, i.e., General managers, Deputy General Manager, Officers-in-chargers or Managers and some shop floor supervisors too.

To verify the leader's responses about the attribution they made for the causes of poor performance, the researcher further investigated the causes of poor performance. Leaders who said that their followers took less interest in doing their jobs, or they are inexperienced, was examined by the researcher, and it was found that some followers had a bad record of explanations or warning issued to them by their leaders, and some were newly appointed followers with less than one years experience. With reference to the external attribution made by the leaders, machines break down history and material supply procedures were examined, and it was noticed that machines, and tool breakdowns reports were excessively high.

Further analysis of data of phase-I indicate that, 60% leaders with high transformational leadership characteristics and 50% with normal leadership characteristics attributed causes to poor performance either to material or tool inventory problems (external attribution) and 10% of the leaders with low transformational leadership characteristics attributed to these causes. With respect to the nature of job of the leaders (transformational and non-transformational), the jobs of all the leaders were concerned with manufacturing operations, but some leaders were more related to fabrication operations, some with assembling operations, and some of them were related to manufacturing management. It was

noted that leaders made attribution (internal as well as external) in all types of jobs, whether it is related to fabrication, assembly, or management. The type of attribution (internal or external) made by the leaders was not dependent upon the nature of the job; it was observed that, leader's attribution towards the causes of poor performance was dependent upon their leadership style. However, Dobbins and Russell (1986), suggested that if poor performance is attributed towards internal factors, which may result in resentment, dissatisfaction, absenteeism, and sabotage by followers, and Wood and Mitchell, (1981), observed that if a follower had a poor work history, the likelihood of an internal attribution is greater. The previous poor work history makes it more likely that the follower will be blamed for the causes of poor performance rather than other factors. If the effects of poor performance are serious or harmful, the internal attributions are even more likely. However, if followers make excuses or apologise for the poor performance, the leader is less likely to make internal attributions.

Attribution theory is a cognitive theory that has been used to explain how a leader interprets information about the poor performance and decides how to react to the poor performance. Green and Mitchell (1979) described the reaction of a leader to poor performance as a two-stage process. The first stage is to determine the cause of poor performance, and the second stage is to select an appropriate response to correct the problem. The type of attribution made by a leader influences the response to the problem. When an external attribution is made, the leader is more likely to respond by trying to change the situation, such as providing resources as required. When an internal attribution is made and the leader determines that the follower had insufficient ability, the likely response is to provide detailed instruction, monitor the follower's work more closely, set easier goals or dead lines, give warning or reprimands to the follower. The assumption considered while answering the question was that, what results if leaders make internal or external attribution? Podsakoff et al (1990) defined transformational leaders behaviour as, to demonstrate the leader's expectations for excellence, quality, and/or high performance on the part of followers and he/she respects followers and is concerned about their personal feelings. Transformational leaders behaviour challenges followers to re-examine some of their assumption about their work and re-think how it can be improved. For example, if leaders tend to make external attributions for the causes of poor performance, although, it is on the part of follower's mistakes (internal causes), but when an external attribution is made, followers had the chance to

improve their performance. When leaders make external attributions, and take appropriate steps to solve the external factors causing poor performance, followers were left with no excuse but to improve their performance. Therefore making external attributions by transformational leaders for the causes of poor performance is observed as one of the behaviour of transformational leadership effectiveness.

It was further noted in the data analysis of qualitative data, that a quarter of the population of leaders of the sample with transformational leadership characteristics attributed their followers as hard working and efficient. However none of the leaders with low transformational leadership characteristics attributed their followers as hard working or efficient. This show that transformational leaders respect and concern for the personal feeling of their followers. Transformational leaders don't let their followers down, but showing themselves as a parent, who ignore the mistakes of the child and always appreciate the child as hard working, although there have been some deficiency in the followers and leaders have not high-lighted them, and favours their followers as hard working. Popper and Mayseless, (2001) reviewed studies dealing with parenting, and compared them with studies with transformational leadership. This comparison reveals a strong similarity between the developmental effects of good parents and those of transformational leaders. It was further noted that none of the leaders with high transformational leadership characteristics attributed the causes of poor performance to technical problems or delays in procurement. Only 10% leaders with normal transformational leadership characteristics attributed the causes of poor performance either to technical problems or delays in procurement and none of the leaders with low transformational leadership characteristics attributed to these causes.

From the data obtained in phase-I (qualitative data), it was further noted that leaders with high or normal transformational leadership characteristics, attributed the causes of poor performance to external factors, i.e., material/tool problems, or technical problems etc. However leaders with low transformational leadership characteristics attribute causes of poor performance to internal factors, i.e., follower's inefficiency, follower's lack of interest or inexperienced followers. It may be noted that in phase-I, leaders were selected for personnel interviewing on the basis of transformational leadership characteristics rated by their followers using Podsakoff et al (1990) transformational leadership inventory questionnaire. 10 leaders were selected on the basis of highest score on transformational leadership characteristics, another

10 leaders were selected on the basis of lowest score and 13 leaders on a mean normal score.

In phase-II, quantitative data collection, the sample size was extended to study the whole organisation, since in phase-I of qualitative data collection, 33 leaders were selected on the basis of transformational leadership scale for interviewing. In phase-II, a total of 76 leaders, 43 leaders whose score were more towards transformational leadership characteristics, 29 leaders attributed the causes of poor performance more towards external factors in some form or the other.

Examining the attributional aspect of the leaders in more detail, it was observed in the data analysis of phase-II that most of the leaders, irrespective of transformational leadership characteristics (more than 80%) were concerned about the opinion of their followers or concerned about the opinion of their leader. When they responded to the question "I should be concerned about the opinion that my followers have about me" as a leader and when they responded to the question, "I should be concerned about the opinion that my leader has about me" as a follower. The logic behind asking this question was to observe the attributions they had about each other and, whether followers and leaders were respecting feelings of each other, if they are respecting each other feelings, they will also pay attention towards the attribution they made about each other. Data showed that both (leader and follower) were concerned about the opinion of each other, i.e., leaders to followers and followers to leaders. According to Fiedler contingency theory, (1967), leadership behaviour is a personality trait. According to Fiedler, how positively the leaders views his or her least preferred co-worker (LPC) depends upon LPC score. High LPC leaders are classified as relationships or people oriented (they tend to feel fairly positive even about people they don't like very much) and low LPC leaders are classified as task oriented. Fiedler's research indicates that when the situation is either favourable to the leader or highly unfavourable group performance was the best if the leader had a low LPC score (i.e., task oriented leaders) whereas in situations of moderate or low favourability to the leader, high LPC score (i.e., person oriented leader) had the best group performance. Favourable or unfavourable situations refer to the extent to which the leader has control over the situation; According to Shackleton (1995) it is more sensible to match the leader's style with the situation, rather than the individual to change to adapt to different situations. Fiedler suggests that a leader should deliberately try to change the situation favourableness by enhancing relations with followers, changing the amount of

structure in a task or gaining more formal power. The results of data analysis shows that transformational leaders respect the concerns of their follower's more than non-transformational leaders do. Leaders irrespective of transformational leadership characteristics are generally trying to establish good relations with followers to improve performance.

However, when the leaders response was analysed for the question about the attribution they had about their followers for the causes of poor performance in phase-II of data analysis, for the question, "My followers are the cause, when things do not go as planned". It was observed that leaders with a low score on the transformational leadership scale made more attribution towards the followers for the causes of poor performance or failure in achieving targets. While, leaders with a high or normal score on transformational leadership characteristics agree less for the causes of poor performance towards the followers.

To look further into the attributions made by leaders to external environment (e.g., vendors problems, material shipment or customs clearance problems) when leaders were asked the question "The external environment of the firm plays a major role in failure or success of the planned processes" as the causes of poor performance. The general response of the leaders irrespective of transformational leadership characteristics was on the neutral side, that is, it may be or may not be, and it depends upon the circumstances of the situation they had at that particular time.

As the aim of the research question about attribution was to look into the behaviour of transformational leaders and to find if they attribute the causes of poor performance to internal or external issues? This study has provided some insights into understanding transformational leaders behaviours with respect to their followers, that is, how transformational leaders exert influence on their followers to perform beyond the leaders expectation for excellence, quality, and/or high performance as described by Podsakoff et al (1990). The data collected from the leaders of manufacturing organisations, indicate that transformational leaders tend to make external attribution for the causes of poor performance. The cause of making external attribution by transformational leaders, show that transformational leaders respect followers and are concerned about the personal feelings of their followers, which is defined as one of the transformational leadership characteristics by Podsakoff et al (1990). As there is yet no direct measurements available in the literature for the attribution made by transformational leaders, however literature on attributional research states that

leaders generally make internal attribution for the causes of poor performance, and followers make external attribution for the causes of poor performance, Shackleton, (1995). This is a general tendency of human nature, to blame others for the causes of failure, and take credit for the success. By making external attribution for the causes of poor performance transformational leaders see followers mistakes as a learning opportunity, and they tend to improve the external environment, provide better opportunities for the performance of the job, and leave behind no clue through which performance may be affected. As a result of leader’s actions, followers modify their behaviours towards the job performance because there was no reason to blame performance to the external environment.

The findings of the research question are consistent with the characteristics of transformational leadership as described by Bass, (1990) that transformational leaders elevate the desires of followers for achievement and self-development, while also promoting the development of groups and organizations. Instead of responding to the immediate self-interest of followers with either a carrot or a stick, transformational leaders arouse in the individual a heightened awareness of key issues, of the group and organization, while increasing the confidence of followers, and gradually moving them from concerns for existence to concerns for achievement, growth and development. Irrespective of actual circumstance making external attributions for the cause of poor performance even when an internal attribution would have been equally valid, transformational leaders for the follower development and confidence, tend to attribute causes of poor performance to external factors. They are leaders who tend to ignore follower’s mistakes, and convert mistakes into a learning experience of followers.

The findings from data analysis shows transformational leaders generally make external attributions for the cause of poor performance in manufacturing organisations.

The study has showed that, transformational leaders tend to make external attributions for the causes of poor performance in manufacturing organisations.

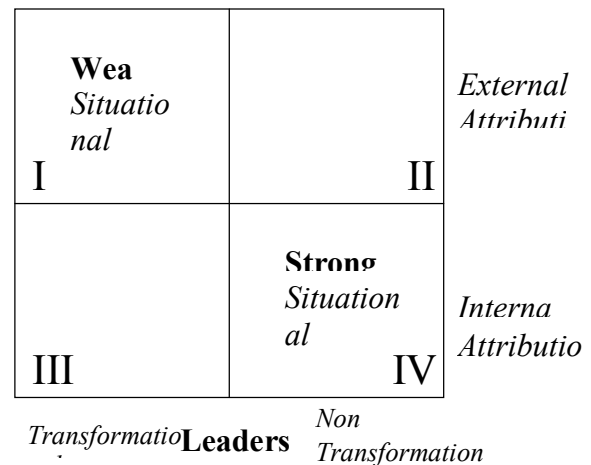
**8. Research Model**

To see if transformational leadership is context-free, context specific, or context-dependent, does the key driver of the emergence and success of transformational leadership lie in strong vs. weak situation, or strong vs. weak leaders, or both? (Avolio & Yammarino,[36]). Research into the attribution theory of leadership is still in its infancy, Shackleton,

(1995) but now there is evidence to reveal the type of attributions made by transformational leaders in a manufacturing environment and the effects that these can have. As indicated by Kark & Shamir, (2002) research on transformational leadership has not fully explored the mechanisms by which transformational leaders exert their influence on followers and ultimately on performance. It is thus necessary to gather data from manufacturing leaders to gain further insights into transformational leadership in manufacturing organisations. Figure 1 presents a framework that represents the type of attribution made by leaders, leadership style and situational strength in a cohesive structure. It comprises of 4-quadrant grid organised around two factors: leadership style and attribution theory.

- Quadrant I - Transformational leadership and External Attribution
- Quadrant II - Non- transformational leadership and External Attribution
- Quadrant III- Transformational leadership and Internal Attribution
- Quadrant IV- Non- transformational leadership and Internal Attribution

The framework suggests that a combination of Transformational leadership with external attribution (Quadrant I) would generate a weak situational strength in the organisation providing more discretion and capability to the followers to manage their tasks. The combination of Non-Transformational and internal attribution (Quadrant IV) would generate a strong situational strength in the organisation providing strict guidelines and structure to the followers for completing their tasks.



**Figure1:** Framework depicting the effect of situational strength on Transformational leadership and Attribution made by leaders.

From this model it can be hypothesised that:

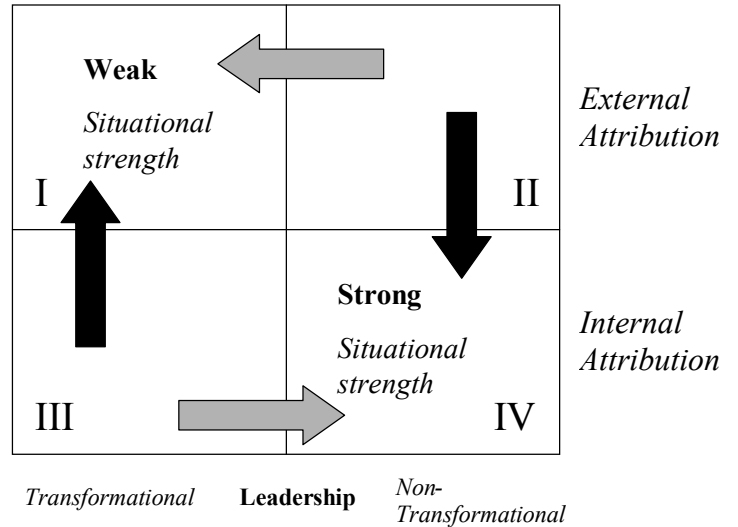
- Transformational leaders prefer to make external attribution for the causes of poor performance.
- Non-transformational leaders prefer to make internal attribution for the causes of poor performance..
- Transformational leaders prefer to create working environments with a weak situational strength for their followers.
- Non-transformational leaders prefer to create working environments with a strong situational strength for their followers.

After analysing the questionnaires, the data was inserted into the research model (figure 2). It can be clearly seen that the preference of transformational leaders is to create a working environment with a weak situational strength for their followers. It can also be inferred that Non-transformational leaders would generally prefer to create working environments with a strong situational strength for their followers. It can also be seen that the results did not provide a complete correlation between type of leadership and situational strength. 65% of the transformational leaders showed a preference for a weak situational strength, whereas 35% showed a preference for strong situational strength. Studying each variable affecting the situational strength and the leaders preference could rectify the discrepancy in these results. Similarly, 74% of the non-transformational leaders showed a preference for a strong situational strength, whereas 26% showed a preference for a weak situational strength. 78% transformational leaders tend to make external attribution for the causes of poor performance and 61% non-transformational leaders tend to make internal attribution for the causes of poor performance.

35	29 External Attribution	34	15 External Attribution	<i>External Attribution</i>
I	23 Weak, 12 Strong	II	26 Strong, 8 Weak	
2	8 Internal Attribution	5	24 Internal Attribution	<i>Internal Attribution</i>
III	1 Strong, 1 Weak	IV	3 Strong, 2 Weak	
<i>Transformational Leadership</i>		<i>Non-Transformational Leadership</i>		

**Figure 2:** The research model incorporating the results

The research model is particularly useful for deciding whether it would be possible to transform leadership style without considering attribution made by leaders. As shown in figure 3, we can hypothesise that if the leader is in quadrant III and would like to maintain his/her transformational style of leadership; he/she should consider attributing to the causes of poor performance to external factors. If the leader is in quadrant II, and would like to maintain his/her non- transformational leadership style, he/she should consider attributing to the causes of poor performance to internal factors.



**Figure 3:** The Alignment model of Leadership

**9. Conclusion**

The study has been successful in knowing about the psychological substructure, the internal world of transformational leaders, namely what “make them tick” and how they developed this way and transformational leadership with the concepts of situational strength and attribution theory. The importance of the study stems from the argument that transformational leadership behaviour influences to a significant degree how followers work and is given freedom to work in organisations. This is useful when issues of motivation, job satisfaction, employee morale, employee training are studied by human resource departments of manufacturing companies. Knowing that the leadership is transformational can make it easier for change and innovation in organisations as it is now known that transformational leaders will thus try to create weak situations where employees are given discretion and freedom to take decisions in their work hence increasing employee morale, and confidence. In addition, the external attribution associated with weak situations promotes confidence among followers. One of the major limitations of

generalising these results is that all the organisations selected for the study were based in Pakistan, and the effect of the national culture may be significant. Since we do not have any other sample of organisations for comparison, at this moment we would like to suggest that the results and discussion are valid for the selected sample and we can assume that it would be valid for other organisations and leaders in that culture.

## 11. References

1. Podsakoff, P.M., MacKenzie, S.B. & Fetter, R. (1990). Transformational leaders behaviours and their effects on followers' trust in leader, satisfaction, and organizational citizenship behaviours. *Leadership quarterly*, 1(2), 107-142.
2. Bass, B.M. (2002). Transformational and charismatic leadership. Volume 2, pp.375-384. Elsevier Science Ltd. ISBN 0-7623-0962-8
3. Scarborough, J.D. (2001). The transformational leadership: An assessment tool. *Journal of Industrial technology*, 18(2).
4. Bass, B.M. (1997). The ethics of transformational leadership. KLSP. Transformational leadership working paper. Academy of leadership press, 1997
5. Bass, B.M., (1999). Two decades of research and development in transformational leadership. *European Journal of work and organizational psychology*. 8,1, 9-32.
6. Conger, J.A. (1999). Charismatic and transformational leadership in organizations: an insider's perspective on these developing streams of research. *Leadership quarterly*, 10, 145-79.
7. House R.J. (1971). A path goal theory of leader effectiveness. *Administrative Science Quarterly*, 16, 321-338.
8. Stogdill, R.M. (1974). *Handbook of leadership*. New York: Free Press.
9. House, R., J., & Baetz, M.L. (1979). Leadership: Some empirical generalizations and new research directions. In B.M. Slaw (Ed.), *Research In Organizational Behaviour* (Vol. 1, pp. 341-423). Greenwich, CT: JAI Press.
10. Bass, B.M. (1981). *Stogdill's handbook of leadership* (rev. ed.). New York; Free Press.
11. Bass, B.M. (1988). Evolving perspective of charismatic leadership. In *Charismatic leadership. The elusive factor in organisational effectiveness*, ed. J.A. Conger and R.N. Kanungo. San Francisco:
12. Yukl, G.A. (1989a). *Leadership in organizations* (2nd ed.). Englewood Cliffs, NJ: Prentice-Hall.
13. Yukl, G.A. (1989b). *Managerial leadership: A review of theory and research*. *Yearly Review of Management*,
14. Burns, J.M. (1978). *Leadership*. New York: Harper & Row.
15. Bass, B.M. (1985). *Leadership and performance beyond expectations*. New York: Free Press.
16. Yukl, G.A. (1989). *Leadership in organisations*. (2nd Eds) State University of New York at Albany, Prentice Hall, Englewood Cliffs, New Jersey 07632.
17. Shamir, B. & Kark, R. (2002). Transformational and charismatic leadership. Volume 2, pp.67-91. Elsevier Science Ltd. ISBN 0-7623-0962-8
18. House, R.J. (1977). A 1976 theory of charismatic leadership. In J.G. Hunt & L.L. Larson (Eds.), *Leadership: The cutting edge*. Carbondale, IL; Southern Illinois University Press.
19. Bennis, W. & Nanis, B. (1985) *Leaders: The strategies/or taking charge*. New York: Harper
20. Tichy, N., & DeVanna, M. (1986). *The transformational leader*. New York: Wiley.
21. Bass, B.M., Avolio, B.J., & Goodheim, L. (1987), *Biography and the assessment of transformational leadership at the world class level*. *Journal of Management*. 13, 7-19.
22. Bass, B.M., Waldman, D.A., Avolio, B.J., & Bebb, M. (1987). Transformational leadership and the falling dominoes effect. *Group and Organization Studies*. 12, 73-87.
23. Conger, J.A. & Kanungo, R. (1987). Toward a behavioural theory of charismatic leadership in organisational settings. *Academy of Management Review*, 12, 637-647.
24. Boal, K.B., & Bryson, J.M. (1988). Charismatic leadership: A phenomenological and structural approach. In J.G. Hunt, B.R. Baliga, H.P. Dachler, & C.A. Schriesheim (Eds.), *Emerging Leadership Vistas* (pp. 5-28). Lexington, MA; Lexington Books.
25. House, R.J., Woycke, J., & Fodor, E.M. (1988). Perceived behaviour and effectiveness of charismatic and non charismatic U.S. presidents. In Conger, J. & Kanungo, R. (Eds.), *Charismatic Leadership and Management*. San Francisco; Jossey-Bass.
26. Avolio, B.J., & Bass, B.M. (1988). Transformational leadership, charisma, and beyond. In J.G. Hunt, B.R. Baliga, H.P. Dachler, & C.A. Schriesheim (Eds.), *Emerging leadership vistas* (pp. 29-49). Lexington, MA: Lexington Books.
27. Shamir, B., House, R.J., & Arthur, M.B. (1988). The transformational effects of charismatic leadership: A motivational theory. Unpublished Working Paper, The Hebrew University, Jerusalem.
28. House, R.J., Spangler, W.D., & Woycke, J. (1989). Personality and charisma in the U.S. presidency: A psychological theory of leadership effectiveness. Working paper, Wharton Business School, University of Pennsylvania.
29. Howell, J.M., & Frost, P.J. (1989). A laboratory study of charismatic leadership. *Organizational Behaviour and Human Decision Processes*, 43, 243-269
30. Bass, B.M. (1999a). Two decades of research and development in transformational leadership. *European Journal of Work and Organisational Psychology*, 8, 9-32.
31. Bass, B.M. (1999b). Current development in transformational leadership: Research and applications. *Psychologist Manager Journal*, 3, 5-21.
32. Bass, B.M., & Avolio, B.J. (1990). The implications for transactional and transformational leadership for individual, team and organisational development. In: R.W. Woodman & W.A. Passmore (Eds), *Research*

- in organisational change and development. Greenwich, CT: JAI Press.
33. Bass, B.M.(1998). Transformational leadership: Industry, military and educational impact. Mahwah,NJ: Erlbaum.
  34. Judge, A., & Bono, J.E.(2000). Five factor model of personality and transformational leadership. *Journal of applied psychology*, 85,751-765.
  35. Maysless, O., & Popper, M. (2002). Transformational and charismatic leadership. Volume 2.pp.203-229. Elsevier Science Ltd. ISBN 0-7623-0962-8
  36. Avolio, B.J. & Yammarino, F.J. (2002) Transformational and charismatic leaders: The Road Ahead. Elsevier Science Ltd. ISBN 0-7623-0962-8.
  38. Fiedler, F.E. (1964). A contingency model of leadership effectiveness. In L. Berkowitz (Ed) *Advances in experimental social psychology*. New York: Academic Press.
  39. Fiedler, F.E. (1967). A theory of leadership. New York: McGraw-Hill.
  40. Carpenter M.A., Golden B.R. (1997); "Perceived managerial Discretion: A study of Cause and Effect", *Strategic Management Journal*, Vol.18, No. 3, pp. 187-206
  41. Beaty J.C., Cleveland J.N., Murphy K.R. (2001), "The relation between personality and contextual performance in Strong versus Weak situations", *Human Performance*, 14(2), 125-148.
  42. Mullins, J W. & Cummings, L L(1999), *Situational Strength: A framework for understanding the role of individuals in initiating proactive strategic change*. *Journal of Organizational Change Management*, Vol. 12, No 6, pp. 462-479.
  43. Carpenter M.A., Fredrickson J.W. (2001). "Top Management Teams, Global Strategic Posture, and The Moderating Role of Uncertainty", *Academy Of Management Journal*, Vol.44, No. 3, pp. 533-545
  44. Sutcliffe K.M., Huber G.P, (1998), " Firm and Industry as Determinants of Executive perceptions of the Environment", *Strategic Management Journal*, 19: 793-807
  45. Wright Peter & Parnell J.A.(1993). "Generic strategy and performance: an Empirical test of the miles and snow typology", *British Journal of Management*, 4, 29-36
  46. Mischel, W. (1977). The Interaction of Person and Situation, Chapter 25. In *Personality at the Crossroads: Current Issues in Interactional Psychology*, edited by David Magnusson and Norman Endler, Lawrence Erlbaum Associates, Publishers.
  47. Dani, S., Burns, N.D. and Backhouse, C.J., "The Effect of Context Upon Leadership Behavior", IEEE International Engineering Management Conference, New York, USA, 2nd November 2003, pp 120-124, ISBN 0-7803-8151-3.
  48. Hughes,R.L.,Ginnett, R.C., & Curphy, G.J. (1993). *Leadership, Enhancing the Lessons of experience*. Irwin, Homewood, IL 60430, Boston, MA 02116
  49. Cameron, K.S., & Ettington, D.R. (1988). *The conceptual foundations of organisational culture*. Higher Education: Handbook of theory and research,pp.356-396. New York:Agathon.
  50. Denison, D. (1989). *Corporate culture and organisational effectiveness*. New York: John Wiley.
  51. Trice, H. & Beyer, J.(1993). *The cultures of work organisations*. Englewood Cliffs, NJ:Prentice Hall.
  52. Ouchi, W.G.(1981). *Theory Z. How American business can meet the Japanese challenge*. Reading, MA:Addison-Wesley.
  53. Pascal, R. & Athos, A.(1981). *The art of Japanese management*. New York: Simon & Schuster.
  54. Peter, T. & Waterman, R. (1982). *In search of excellence*. New York: Harper and Row.
  55. Deal, T.E., & Kennedy, A.A. (1982). *Corporate culture: The rights and rituals of corporate life*. Reading, MA: Addison-Wesley.
  56. Hofstede, G. (1980). *Culture's consequences*. London: Sage.
  57. Trompenaars, F. (1992). *Riding the waves of cultures: Ultrastranding Diversity in global business*. New York, Irwin.
  58. Cameron, K.S. & Quinn, R.E.(1999) *Diagnosing and changing organisational culture*. Addison-Wesley Longman Inc.
  59. Creswell, J.W. (2003). *Research Design, Qualitative, Quantitative, and mixed Methods Approaches*. (2nd Edn) University of Nebraska, Lincoln, Sage Publications International Educational and Professional Publisher, Thousand Oaks, London, New Delhi

1/29/2012



## Curcumin Reduced Potato Chips and Roasted Bread Induced Chromosomal Aberrations and Micronuclei Formation in Albino Rats

Ramadan A.M. Ali, Nadia H.M. Sayed and Dalia D. Abd El-Monem

Zoology Dept, Girls Collage for Arts, Science and Education, Ain Shams Univ., Heliopolis, Egypt  
[ramadanali27@gmail.com](mailto:ramadanali27@gmail.com)

**Abstract:** Detection of high concentrations of acrylamide (AA) in heated starch rich foodstuffs raises health concerns, particularly for children, because AA is relatively high in child-favored foods such as potato chips, French fries, roasted bread and cereals. So, we investigated the genotoxic and cytotoxic potentials of potato chips (FP) and roasted bread (RB) and the possible protective effect of curcumin (Cur) in albino rat bone-marrow cells, using chromosomal aberrations (CAs) and micronucleus (Mn-PCEs) assays. 90 adult female rats were divided into 15 groups 6 animals each. Rats feed on diet contained 15 % or 30 % of fried potato chips and/or fried bread and supplemented with/without 1%curcumin addition for 2 months. Results showed that, treatment with Cur alone did not induce significant increases in CAs and Mn-PCEs in comparison to the control level. Meanwhile, diet supplemented with 30 % of FP and/or RB induced highly significant increases in CAs and Mn-PCEs frequencies ( $P < 0.001$ ). Moreover, fried potato chips and/or fried bread caused cytotoxic action in the form of a significant reduction in the proportion between polychromatic erythrocytes to normochromatic erythrocytes. Meanwhile, addition of 1% Cur powder induced significant decrease in CAs and Mn-PCEs frequencies in comparison to those induced by FP and/or RB alone. Such increases were dose dependent. On conclusion, curcumin exhibited antimutagenic properties against the mutagenicity induced by potato chips and/or roasted bread which make it a promising chemopreventive agent.

[Ramadan A.M. Ali Nadia H.M. Sayed and Dalia D. Abd El-Monem. **Potato Chips and Roasted Bread Induced Chromosomal Aberrations and Micronuclei Formation in Albino Rats.** Life Science Journal. 2012; 9(1):330-336] (ISSN: 1097-8135). <http://www.lifesciencesite.com>. 47

**Key words:** Acrylamide, Curcumin, Chromosomes, Micronucleus, Rat, Potatoes chips, Roaster bread.

### Introduction:

Frying food in fats and oils is a popular food preparation method. A huge public concern was generated after detecting a considerable concentration of the genotoxic and carcinogenic acrylamide in starch-containing foods cooked at high temperatures as fried potatoes, potato chips and the brown roasted bread (Taubert *et al.*, 2004).

Epidemiological studies gave an evidence for cancer risk factor in correlation with consumption of the fried potatoes and the acrylamide content in foods with the incidences of cancer in various body organs. For instance, analysis of epidemiological data showed a parallel link between high consumption of fried potatoes cooked at high temperatures and risk of bladder cancer in a case-control study in Uruguay (De Stefani *et al.*, 2008), risk of lung cancer among Canadian women due to evaporated burned oils (Hu *et al.*, 2002), risk of laryngeal cancer in a case-control study from Italy and Switzerland (Bosetti *et al.*, 2002), cancer risk of oral cavity, pharynx, esophagus, larynx, breast, colon and rectum (Pelucchi *et al.*, 2004) and risk of renal cell carcinoma from a population-based Swedish case-control study (Mucci *et al.*, 2004), risk of pancreatic cancer in an Italian case-control study (Pelucchi *et al.*, 2011).

Acrylamide induced single and double-strand DNA breaks and DNA adducts (Koyama *et al.*, 2011). More-

over, acrylamide possessed mutagenic activity as revealed by chromosomal aberration, sister-chromatid exchange and micronucleus assays. Acrylamide induced chromosomal aberrations in mouse zygotes (Marchetti *et al.*, 1997), in bone marrow and spleen cells of mice and rats (Krishna and Theiss, 1995), in spermatogenic cells (Schmid *et al.*, 1999) and in Chinese hamster V79 cells (Oliveira *et al.*, 2009). Acrylamide also decreased the mitotic activity of rat bone marrow cells (Yener and Dikmenli, 2011). Moreover, acrylamide induced sister-chromatid exchanges in spleen cells (Backer *et al.*, 1989), in mice bone marrow cells (Russo *et al.*, 1994) and in Chinese hamster V79 cells (Oliveira *et al.*, 2009). In addition, acrylamide proved to be a potent micronuclei inducer in peripheral blood erythrocytes and spermatids of mice (Russo *et al.*, 1994), in spleen cells of mice (Krishna and Theiss, 1995), in human lymphoblastoid TK6 cells (Koyama *et al.*, 2006) and in bone marrow cells of mice and rats (Koyama *et al.*, 2011).

Curcumin powder is a yellow pigment obtained from ground dried root rhizomes of curcuma plant (*Curcuma longa*), commonly used as natural food additive as a spice and food coloring agent. Curcumin is able to inhibit the genotoxic and histochemical changes induced in the experimental animals by various chemical agents as it reduced the percentages of micronucleated polyc-

chromatic erythrocytes in bone marrow cells of mice (Azuine *et al.*, 1992) and inhibited chromosomal aberrations, micronuclei formation, and sister chromatid exchanges (SCEs) incidences in mouse bone marrow cells induced by benzo(a)pyrene (Shukla *et al.*, 2003) and lead acetate (El-Ashmawy *et al.*, 2006). Moreover, curcumin reduced the levels of benzo[a]pyrene-DNA adducts in liver, lung, and forestomach (Thapliyal *et al.*, 2002) and DNA damage induced by benzo[a]pyrene in human peripheral blood lymphocyte cells as revealed by single cell gel electrophoresis assay (Polasa *et al.*, 2004). In addition, Curcumin has been shown to inhibit chemical carcinogenesis (Garg *et al.*, 2008) and chemical mutagenesis (Peng *et al.*, 2010).

This investigation aimed to show the frequencies of damaged cells (DC) and micronuclei in polychromatic erythrocytes (Mn-PCEs) induced by feeding female rats with diets containing fried potato chips and roasted bread for a long time. As well as to reduce the induced chromosomal aberrations through feeding the animals with the same diets supplemented with 1 % curcumin powder.

## Material and methods

### A- Animals and treatments:

The experiments were carried out on 90 adult female albino rats 3-4 months age and 130-150 g in weight which were purchased from Helwan Farms of the Egyptian Organization for Vaccines and Biological Preparations, Cairo. Rats were accommodated according to the protocol of animal welfare of Ain Shams University in which the commercial food and tap water were supplemented ad libitum during the acclimatization and the experimental period. Animals were divided into 15 groups 6 animals each. Table (1) shows animal groups, treatment schedule and the composition of diet for each animal group. Animals feed on diet contained 15 % or 30 % of fried potato chips and/or fried bread and supplemented with/without 1% curcumin addition for 2 months.

### B-Chemicals

AA with 99% purity was purchased from sigma chemical company. It is white powder, water-soluble vinyl monomer. With molecular formula:  $C_3H_5NO$  and chemical formula:  $CH_2=CHCONH_2$ . Curcumin powder was obtained from the local herbal shop.

### C- Preparation of fried potatoes and roasted bread

The fried potatoes chips were prepared according to the protocol regularly applied in the home: potatoes were washed with the tap water and the covering skin removed with a sharp knife and the potatoes pulps trimmed into thin slices (chips) with a thickness about 1 to 2 mm approximately. Commercial frying oil current-

ly consumed by the native Egyptians was chosen from the supermarket.

After oil boiling, the potatoes slices were dropped into the boiled oil till the surface of slices turned into golden brown in color. Similarly, the bread of whole wheat seed was fried by the same way. The fried potatoes slices and the roasted bread were fragmented into powder and added to the commercial diet in appropriate percentages.

### 2-D- Chromosomal aberrations assay:

Metaphase chromosomal spreads were prepared from bone marrow cells by air-drying technique previously postulated by Hliscs *et al.* (1997). Animals were injected intraperitoneally with colchicine (1 cc/200g b.w. from 0.04 % colchicine powder in  $dH_2O$ ) 2 h prior to chromosomal preparation. Animals were killed by cervical dislocation and bone marrow of femur was aspirated for chromosomal preparation. The prepared slides were stained with 5% Giemsa stain. Chromosomal aberrations were scored and recorded among 100 well-spread metaphase /animal. Moreover, mitotic index was calculated by counting the dividing cells among 2000 cells/ animal and expressed in percentage.

### E- Micronucleus assay:

Micronucleus assay in polychromatic erythrocytes of bone marrow was carried out by the method of Schmid (1976) from bone marrow of the femur. The bone marrow was flushed in the form of a fine cell suspension into a centrifuge tube containing 1 ml of fetal calf serum. The cell suspension was centrifuged at 1000 r.p.m. for 5 min and the supernatant was discarded. The pellet was resuspended in a drop of serum for slides preparing. The air-dried slides were stained with Giemsa. A total of 2,500 polychromatic erythrocytes (PCEs) were scored per animal to determine the frequency of Mn-PCEs. In addition, the ratio of PCE to NCE was recorded.

### F- Statistical analysis:

All the data were analyzed with Student's *t*-test and a *P*- value ( $P < 0.05$ ) was considered statistically significant (Fowler *et al.*, 1998).

## Results and Discussion

As shown in tables (2 and 3) and figures (1 and 2); diet supplemented with 30 % of FP and/or RB exhibited 13, 16 and 8.33 damaged cell / 100 metaphase spreads and 18.67, 21.16 and 12.83 Mn-PCEs / 2500 PCEs, respectively. Furthermore, animals feed on FP induced higher incidences of damaged cells and micronuclei in comparison to those feed on RB. This observation could be explained through the fact that, animals treated with

fried potatoes were subjected to the effect of both the oxidative compounds of boiled oil and the brown crust which containing acrylamide (**Becalski et al., 2003**).

The fried potatoes and the roasted bread possibly induced the chromosome breaking activity through three mechanisms: 1- The natural antioxidants content present in oils and potatoes are declined through frying process at high temperatures. The process of food frying destruct the natural antioxidants present in oil and potatoes as (alpha-tocopherol and phenolic compounds) which led to the lipid peroxidation in liver microsomes of rats after feeding with the fried potatoes (**Quiles et al., 2002 and Yen et al., 2010**). This assumption was ascertained by **Andrikopoulos et al. (2002)** who observed that the fried oil content of antioxidants was deteriorated during eighth successive frying of virgin olive oil, sunflower oil and a vegetable shortening. Where, the retention of tocopherols ranged from 85-90% (first frying) to 15-40 (eighth frying) except for tocopherols of sunflower oil, which almost disappeared after the sixth frying and the retention of total phenolics ranged from 70-80% (first frying) to 20-30% (eighth frying). In addition, **Battino et al. (2002)** observed that, the intake of such altered oil by rats mainly affected the respiratory chain components (Coenzyme Q, cytochromes) of the mitochondrial membranes which are considered as another source for genotoxicity.

The boiling of oils at high temperatures induced the formation of genotoxic oxidative compounds (**Dung et al., 2006**). Deep fat frying is a popular food preparation method because it produces desirable fried food flavor, golden brown color and crisp texture (**Warner, 1999**). Throughout, deep frying of oils, the oxidation process of oils is occurred and the genotoxic derivatives like linoleic acid hydroperoxides and squalene compounds are produced (**Chaiyasit et al., 2007**). **Hageman et al. (1989 and 1990)** found that, linoleic acid hydroperoxides extracted from deep-frying fat samples induced mutagenicity to Salmonella tester strains TA97 and TA100, in presence of S9 mix. Moreover, consumption of heated oils by rats enhanced cell proliferation of the esophagus lining epithelium cells (**Hageman et al., 1991**). In addition, **Kalogeropoulos and Andrikopoulos (2004)** detected the genotoxic agents, squalene compounds that produced during deep-frying of potatoes.

The formation of the chemical compound known as acrylamide during heating of starch with the amino acid asparagine in the brown crust of fried potatoes and roasted bread (**Pedreschi and zuniga, 2009**). Asparagines, is the major amino acid in potatoes and cereals, which acts as a crucial participant in the production of acrylamide (**Mottram et al., 2002**). Moreover, **Tarke et al. (2002)** detected a moderate level of acrylamide (5-50 microg/kg) in heated protein-rich foods and

higher contents (150-4000 microg/kg) in carbohydrate-rich foods, such as fried potatoes. Furthermore, the acrylamide content consistently increased with increasing temperature and processing times (**Majcher and Jeleń, 2007**).

Acrylamide acts as an indirect genotoxic agent and cannot induce chromosomal damage but it converted to the mutagenic metabolite glycidamide in the liver cells. Glycidamide is potent genotoxic agent (**Puppel et al., 2005**). It induced DNA adducts in normal human bronchial epithelial cells and Big Blue mouse embryonic fibroblasts, (**Besaratinia and Pfeifer, 2004**), in V79 Chinese hamster cells (**Matins et al., 2007**) and in mouse lymphoma cells (**Mei et al., 2008**).

On the other hand, diet supplement contains several natural substances capable of inhibiting genotoxic chemicals either directly by scavenging the reactive substances or indirectly by promoting mechanisms, which enhance detoxification of mutagenic agents.

This investigation revealed also that, curcumin significantly reduced the percentages of damaged cells from  $3.67 \pm 0.8$  to  $2.33 \pm 0.8$  damaged cells/100 metaphase and from  $13 \pm 1.34$  to  $8 \pm 1.03$  damaged cells/100 metaphase induced by 15% and 30% FP, respectively. Similarly, curcumin significantly reduced the percentages of damaged cells from  $3.67 \pm 0.8$  to  $2.33 \pm 0.8$  damaged cells/100 metaphase and from  $13 \pm 1.34$  to  $8 \pm 1.03$  damaged cells/100 metaphase induced by 15% and 30% FP, respectively. Furthermore, it inhibited the mean frequencies of micronuclei induced by 30% FP from  $18.67 \pm 1.02$  to  $11.17 \pm 0.98$  Mn-PCEs / 2500 PCEs and 30% RB from  $12.83 \pm 0.79$  to  $9.17 \pm 1.25$  Mn-PCEs / 2500 PCEs (as presented in tables 2&3.)

Curcumin may be induced its antigenotoxicity via liver antioxidant enzymes superoxide dismutase, catalase and glutathione peroxidase (**Reddy and Lokesh, 1994**) which lowered lipid peroxidation and protected rats from iron-induced lipid peroxidation. Curcumin pretreatment protect mice from DNA damage and carcinogenicity induced by benzo(a)pyrene and isothiocyanate via superoxide dismutase, catalase and glutathione peroxidase production (**Polasa et al., 2004**). Another possible mechanism for antigenotoxicity of curcumin via reducing the activity of cytochrome P450 (CYP450) isozymes CYP 1A1, 1A2 and 2B1 in liver, lung, and forestomach and elevating the activity of hepatic glutathione S-transferase (**Singh and Sharma, 2011**).

On conclusion, curcumin the yellow pigment commonly used as a spice and food coloring agent obtained from rhizomes of *Curcuma longa* exhibited antimutagenic properties on the genotoxicity induced by fried potatoes and roasted bread.

**Table (1): Categorization of the animal groups according to the percentage of diet content of fried potato chips, roasted bread, Curcumin and commercial diet.**

Treatment (Group / 6 animals)	Diet Composition (%)				
	Fried Potato Chips	Roasted bread	Curcumin	Acrylamide	Commercial Diet
Control 1	-	-	-	-	100
Control 2	-	-	1	-	99
Positive Control	-	-	-	1	99
Without Curcumin	FP 15%	15	-	-	85
	RB 15%	-	15	-	85
	FP+RB 15%	15	15	-	70
	FP 30 %	30	-	-	70
	RB 30 %	-	30	-	70
	FP + RB 30 %	30	30	-	40
With Cur- cumin	FP 15%	15	-	1	84
	RB 15%	-	15	1	84
	FP+RB 15%	15	15	1	69
	FP 30 %	30	-	1	69
	RB 30 %	-	30	1	69
	FP + RB 30 %	30	30	1	39

Control 1 = Includes animals feed only on the commercial diet

Control 2 = Included animals feed on commercial diet and supplemented with 1 g turmeric

RB = Roasted bread

FP = Fried potatoes chips

**Table (2): Average of damaged metaphases induced in bone marrow cells of animals feed on diet contained 15 % or 30 % of fried potatoes chips and/or fried bread and supplemented with/without curcumin addition for 2 months.**

Treatment	Number of damaged cells			Mitotic index		
	Total	Mean %	SE ±	Mean%	SE ±	
Control	10	1.67	0.61	3.83	0.30	
1% Curcumin	4	0.67	0.21 <sup>*</sup>	4.33	0.33 <sup>*</sup>	
1%AA	133	22.16	0.91 <sup>*****</sup>	1.16	0.16	
Without Curcumin	FP 15%	22	3.67	0.80 <sup>*</sup>	3.00	0.25 <sup>*</sup>
	RB 15%	16	2.67	0.66 <sup>*</sup>	3.50	0.42 <sup>*</sup>
	FP + RB 15%	30	5.00	0.85 <sup>***</sup>	2.83	0.30 <sup>**</sup>
	FP 30%	78	13.0	1.34 <sup>*****</sup>	2.00	0.25 <sup>****</sup>
	RB 30%	50	8.33	0.95 <sup>*****</sup>	2.50	0.34 <sup>**</sup>
	FP + RB 30%	96	16.0	1.46 <sup>*****</sup>	1.33	0.21 <sup>*****</sup>
With Curcumin	FP 15%	14	2.33	0.80 <sup>a</sup>	3.50	0.34 <sup>a</sup>
	RB 15%	12	2.00	0.51 <sup>b</sup>	4.00	0.36 <sup>b</sup>
	FP + RB 15%	24	4.00	0.89 <sup>c</sup>	3.00	0.36 <sup>c</sup>
	FP 30%	48	8.00	1.03 <sup>d</sup>	2.50	0.22 <sup>c</sup>
	RB 30%	30	5.00	1.12 <sup>f</sup>	3.00	0.45 <sup>e</sup>
	FP + RB 30%	71	11.83	1.1 <sup>h</sup>	1.50	0.22 <sup>i</sup>

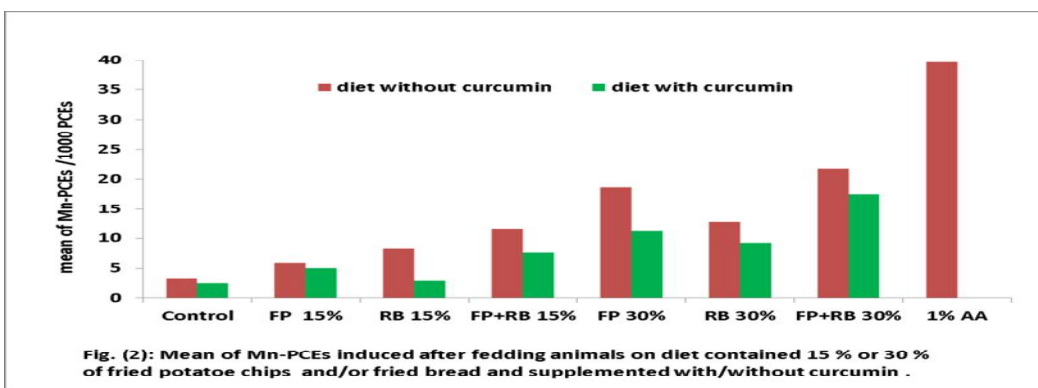
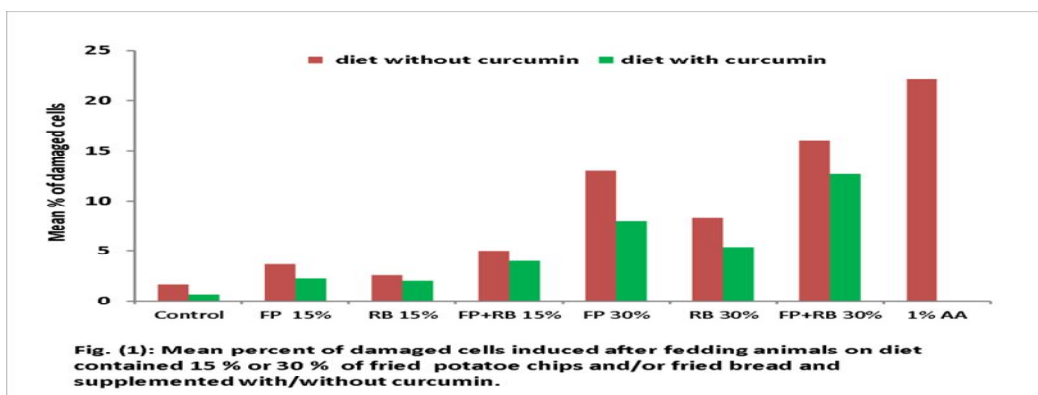
AA = Acrylamide FP = fried potatoes chips RB= fried bread SE=Standard error

<sup>\*</sup>P>0.05 compared with control<sup>\*\*</sup>P<0.05 compared with control<sup>\*\*\*</sup>P<0.01 compared with control<sup>\*\*\*\*</sup>P<0.001 compared with control<sup>\*\*\*\*\*</sup>P<0.0001 compared with control<sup>a</sup>P>0.05 compared with 15% FP<sup>b</sup>P>0.05 compared with 15%RB <sup>c</sup>P>0.05 compared with 15% FP +RB <sup>d</sup>P<0.001 compared with 30%FP <sup>e</sup>P>0.05 compared with 30% FP<sup>f</sup>P<0.05 compared with 30%RB <sup>g</sup>P>0.05 compared with 30%RB<sup>h</sup>P<0.05 compared with 30% FP +RB <sup>i</sup>P<0.05 compared with 30% FP +RB

**Table (3): Frequency of micronucleated erythrocytes and PCE/NCE ratio induced in bone marrow cells of rats feed on diet contained fried potatoes chips and/or fried bread and supplemented with/without curcumin addition.**

Treatment	The frequency of MN			PCE/NCE	
	Total Mn/15000 PCEs	Mean Mn/2500 PCEs	SE ±	Mean%	SE ±
Control	20	3.33	0.56	53.50	0.84
1% Curcumin	15	2.5	0.65*	56.00	0.77*
1%AA	238	39.66	1.14****	30.83	1.08****
Without Curcumin	FP 15%	35	5.83	46.83	1.08***
	RB 15%	50	8.33	49.67	0.56**
	FP + RB 15%	70	11.67	44.50	1.23****
	FP 30%	112	18.67	35.50	1.38****
	RB 30%	77	12.83	43.17	0.60****
	FP + RB 30%	130	21.16	29.83	0.87****
	With Curcumin	FP 15%	30	5.00	51.67
RB 15%		17	2.83	52.33	0.42 <sup>c</sup>
FP + RB 15%		46	7.67	50.50	0.84 <sup>e</sup>
FP 30%		67	11.17	38.17	1.25 <sup>g</sup>
RB 30%		55	9.17	44.67	0.76 <sup>i</sup>
FP + RB 30%		105	17.5	31.50	1.17 <sup>k</sup>

AA = Acrylamide; FP = fried potatoes chips; RB= fried bread; SE=Standard error  
 \*P>0.05 compared with control; \*\*P<0.01 compared with control; \*\*\*P<0.001 compared with control  
 \*\*\*\*P<0.0001 compared with control; <sup>a</sup>P>0.05 compared with 15% FP; <sup>b</sup>P<0.01 compared with 15%FP<sup>c</sup>P<0.01 compared with 15%RB <sup>d</sup>P<0.05 compared with 15% FP +RB<sup>e</sup>P<0.01 compared with 15% FP +RB<sup>f</sup>P<0.001 compared with 30%FP<sup>g</sup>P>0.05 compared with 30%FP<sup>h</sup>P<0.05 compared with 30%R; <sup>i</sup>P>0.05 compared with 30%FP<sup>j</sup>P<0.05 compared with 30% FP +RB<sup>k</sup>P>0.05 compared with 30% FP +RB.



**Corresponding author**

Ramadan A.M. Ali

Zoology Dept, Girls Collage for Arts, Science and Education, Ain Shams Univ.

[ramadanali27@gmail.com](mailto:ramadanali27@gmail.com)**References**

1. **Andrikopoulos, N.; Dedoussis, G.; Falirea, A.; Kalogeropoulos, N. and Hatzinikola, S. (2002):** Deterioration of natural antioxidant species of vegetable edible oils during the domestic deep-frying and pan-frying of potatoes. *Int. J. Food Sci. Nutr.*, 53(4): 351-363.
2. **Azuine, M.; Kayal, J. and Bhide, V. (1992):** Protective role of aqueous turmeric extract against mutagenicity of direct-acting carcinogens as well as benzo [alpha] pyrene-induced genotoxicity and carcinogenicity. *J. Cancer Res. Clin. Oncol.*, 118(6): 447-452.
3. **Backer, C.; Dearfield, L.; Erexson, L.; Campbell, A.; Westbrook-Collins, B. and Allen, W. (1989):** The effects of acrylamide on mouse germ-line and somatic cell chromosomes. *Environ. Mol. Mutagen.*, 13(3): 218-226.
4. **Battino, M.; Quiles, J.; Huertas, R.; Ramirez-Tortosa, C.; Cassinello, M.; Manas, M.; Lopez-Frias, M. and Mataix, J. (2002):** Feeding fried oil changes antioxidant and fatty acid pattern of rat and affects rat liver mitochondrial respiratory chain components. *J. Bioenerg. Biomembr.*, 34(2):127-134.
5. **Becalski, A.; Laup, Lewis, D. and Seaman, W. (2003):** Acrylamide in foods: occurrence, sources, and modeling. *J. Agric. Food Chem.*, 51(3):802-808.
6. **Besaratinia, A. and Pfeifer, P. (2004):** Genotoxicity of acrylamide and glycidamide. *J. Natl. Cancer Inst.*, 96(13): 1023-1029.
7. **Bosetti, C.; Talamini, R.; Levi, F.; Negri, E.; Franceschi, S.; Airoldi, L. and La Vecchia, C. (2002):** Fried foods: a risk factor for laryngeal cancer. *Br. J. Cancer*, 87(11): 1230-1233.
8. **Chaiyasit, W.; Elias, R.J.; McClements, D.J. and Decker, E.A. (2007):** Role of physical structures in bulk oils on lipid oxidation. *Crit. Rev. Food Sci. Nutr.*, 47(3): 299-317.
9. **De Stefani, E.; Boffetta, P.; Ronco, A.L.; Deneo-Pellegrini, H.; Acosta, G. and Mendilaharsu, M. (2008):** Dietary patterns and risk of bladder cancer: a factor analysis in Uruguay. *Cancer Causes Control*, 19(10): 1243-1249.
10. **Dung, C.H.; Wu, S.C. and Yen, G. C. (2006):** Genotoxicity and oxidative stress of the mutagenic compounds formed in fumes of heated soybean oil, sunflower oil and lard. *Toxicology in Vitro*, 20 (4): 439-447.
11. **El-Ashmawy, I. M.; Ashry, K. M.; El-Nahasa, F. and Salama, O. M. (2006):** Protection by turmeric and myrrh against liver oxidative damage and genotoxicity induced by lead acetate in mice. *Basic Clin. Pharmacol. Toxicol.*, 98(1):32-7.
12. **Fowler J., Cohen L. and Jarvis P. (1998).** Practical statistics for field biology. 2<sup>nd</sup> ed. John Wiley & Sons, Chichester, New York
13. **Garg, R.; Ingle, A. and Maru, G. (2008):** Dietary turmeric modulates DMBA-induced p21ras, MAP kinases and AP-1/NF-kappa B pathway to alter cellular responses during hamster buccal pouch carcinogenesis. *Toxicol. Appl. Pharmacol.*, 232(3): 428-439.
14. **Hageman, G.; Hermans, R.; Ten Hoor, F. and Kleinjans, J. (1990):** Mutagenicity of deep-frying fat, and evaluation of urine mutagenicity after consumption of fried potatoes. *Food Chem. Toxicol.*, 28(2): 75-80.
15. **Hageman, G.; Verhagen, H.; Schutte, B. and Kleinjans, J. (1991):** Biological effects of short-term feeding to rats of repeatedly used deep-frying fats in relation to fat mutagen content. *Food Chem. Toxicol.*, 29(10): 689-698.
16. **Hageman, G.; Kikken, R.; Ten Hoor, F. and Kleinjans, J. (1989):** Linoleic acid hydroperoxide concentration in relation to mutagenicity of repeatedly used deep-frying fats. *Lipids*, 24(10): 899-902.
17. **Hliscs, R.; Muhlig, P. and Claussen, U. (1997):** The spreading of metaphases in a slow process which leads to stretching of chromosomes. *Cytogenet. Cell Genet.*, 76: 167-171.
18. **Hu, J.; Mao, Y.; Dryer, D. and White, K. (2002):** Risk factors for lung cancer among Canadian women who have never smoked. *Cancer Detect. Prev.*, 26(2): 129-138.
19. **Kalogeropoulos, N. and Andrikopoulos, K. (2004):** Squalene in oils and fats from domestic and commercial fryings of potatoes. *Int. J. Food Sci. Nutr.*, 55(2): 125-129.
20. **Koyama, N.; Sakamoto, H.; Sakuraba, M.; Koizumi, T.; Takashima, Y.; Hayashi, M.; Matsufuji, H.; Yamagata, K.; Masuda, S.; Kinae, N. and Honma, M. (2006):** Genotoxicity of acrylamide and glycidamide in human lymphoblastoid TK6 cells. *Mutat. Res.*, 28 603(2): 151-158.
21. **Koyama, N.; Yasui, M.; Kimura, A.; Takami, S.; Suzuki, T.; Masumura, K.; Nohmi, T.; Masuda, S. Kinae, N. Matsuda, T. Imai T. and Honma M. (2011):** Acrylamide genotoxicity in young versus adult gpt delta male rats. *Mutagenesis.*, 26(4): 545-549.
22. **Krishna, G. and Theiss, C. (1995):** Concurrent analysis of cytogenetic damage *in vivo*: a multiple endpoint –multiple tissue approach. *Environ. Mol. Mutagen.*, 25(4): 314-320.
23. **Majcher, M. A. and Jeleń, H. H. (2007):** Acrylamide formation in low-fat potato snacks and its correlation with colour development . *Food Additives and Contaminants*, 24 (4): 337-342
24. **Martins, C.; Oliveira, G.; Pingarilho, M.; Gamboa, Da Costa, G.; Martins, V.; Marques, M. M.; Bel-**

- and, F.A.; Churchwell, M. I.; Doerge, D. R.; Rueff, J. and Gaspar, J. F. (2007): Cytogenetic damage induced by acrylamide and glycidamide in mammalian cells: correlation with specific glycidamide-DNA adducts. *Toxicol. Sci.*, 95(2): 383-390.
25. Mei, N.; Hu, J.; Churchwell, M.I.; Guo, L.; Moore, M.M.; Doerge, D.R. and Chen, T.(2008): Genotoxic effects of acrylamide and glycidamide in mouse lymphoma cells. *Food Chem. Toxicol.*, 46(2): 628-636.
  26. Marchetti, F.; Lowe, X.; Bishop, J. and Wyrobek, A. J. (1997): Induction of chromosomal aberrations in mouse zygotes by acrylamide treatment of male germ cells and their correlation with dominant lethality and heritable translocations. *Environ. Mol. Mutagen.*, 30(4): 410-417.
  27. Mottram, S.; Wedzicha, L. and Dodson, T. (2002): Acrylamide is formed in the Maillard reaction. *Nature*, 419: 448-449.
  28. Mucci, L.A. ; Lindblad, P. ; Steineck, G. and Adami, O. (2004): Dietary acrylamide and risk of renal cell cancer. *Int. J. Cancer*, 109(5): 774-776.
  29. Oliveira, N.G.; Pingarilho, M.; Martins, C.; Fernandes, A.; S. Vaz, S.; Martins, V.; Rueff, J. and Gaspar, J. F. (2009): Cytotoxicity and chromosomal aberrations induced by acrylamide in V79 cells: role of glutathione modulators. *Mutat. Res.*, 676(1-2): 87-92.
  30. Pedreschi, F.; and Zuniga, R. N. (2009): Acrylamide and Oil Reduction in Fried Potatoes: A Review. *Food*, 3(2): 82-92.
  31. Pelucchi, C.; Franceschi, S.; Levi, F.; Trichopoulos, D. ; Bosetti, C.; Negri, E. and La Vecchia, C. (2004): Fried potatoes and human cancer. *Int. J. Cancer*, 108(4): 634-635.
  32. Pelucchi, C.; Galeone, C.; Talamini, R.; Negri, E.; Polesel, J.; Serraino, D. and La Vecchia, C. (2011): Dietary acrylamide and pancreatic cancer risk in an Italian case-control study. *Ann. Oncol.*, 22(8): 1910-1915.
  33. Peng, C.H.; Chiu, W.T. ; Juan, C.W.; Mau, J.L.; Chen, C.C.; Peng, C.C.; Lai, E.Y. and Chyau, C.C. (2010): Pivotal role of curcuminoids on the antimutagenic activity of Curcuma zedoaria extracts. *Drug Chem. Toxicol.*, 33(1): 64-76.
  34. Polasa, K. ; Naidu, N. ; Ravindranath, I. and Krishnaswamy, K. (2004): Inhibition of B(a)P induced strand breaks in presence of curcumin. *Mutat. Res.*, 557(2): 203-213.
  35. Puppel, N.; Tjaden, Z.; Fueller, F. and Marko, D. (2005): DNAstrandbreakingcapacity of acrylamide and glycidamide in mammalian cells. *Mutat. Res.*, 580(1-2): 71-80.
  36. Quiles, L. ; Huertas, R. ; Battino, M. ; Ramirez-Tortosa, C. ; Cassinello, M. ; Mataix, J. ; Lopez-Frias, M. and Manas, M. (2002): The intake of fried virgin olive or sunflower oils differentially induces oxidative stress in rat liver microsomes. *Br. J. Nutr.*, 88(1): 57-65.
  37. Reddy, C. and Lokesh, R. (1994): Effect of dietary turmeric (*Curcuma longa*) on iron-induced lipid peroxidation in the rat liver. *Food Chem. Toxicol.*, 32(3): 279-283.
  38. Russo, A.; Gabbani, G. and Simoncini, B. (1994): Weak genotoxicity of acrylamide on premeiotic and somatic cells of the mouse. *Mutat. Res.*, 309(2): 263-272.
  39. Schmid, E.; Xu, W. and Adler, D. (1999): Detection of aneuploidy by multicolor FISH in mouse sperm after in vivo treatment with acrylamide, colchicine, diazepam or thiabendazole. *Mutagenesis*, 14(2): 173-179.
  41. Schmid, W. (1976): The micronucleus test for cytogenetic analysis. In Hollaender, A. (ed.), *Chemical Mutagens, Principles and Methods for their detection*, Vol. 4. Plenum Press, New York, pp. 31—53.
  41. Shukla, Y. ; Arora, A. and Taneja, P. (2003): Antigenotoxic potential of certain dietary constituents. *Teratog. Carcinog. Mutagen.*, Suppl 1: 323-335.
  42. Singh, R. and Sharma, P. (2011): Hepatoprotective Effect of Curcumin on Lindane-induced Oxidative Stress in Male Wistar Rats. *Toxicol. Int.*, 18(2): 124-129.
  43. Tareke, E.; Rydberg, P. and Karlsson, P. (2002): Analysis of ACR, a carcinogen formed in heated foodstuffs. *J. Agric. Food Chem.*, 50 (17): 4998–5006.
  44. Taubert, D.; Harlfinger, S.; Henkes, L.; Berkels, R. and Schomig, E. (2004): Influence of processing parameters on acrylamide formation during frying of potatoes. *J. Agric. Food Chem.*, 52(9): 2735-2739.
  45. Thapliyal, R. ;Deshpande, S. and Maru, B. (2002): Mechanism(s) of turmeric-mediated protective effects against benzo(a)pyrene-derived DNA adducts. *Cancer Lett.*, 175(1): 79-88.
  46. Warner, K. (1999): Impact of high-temperature food processing on fats and oils. *Adv. Exp. Med. Biol.*, 459: 67-77
  47. Yen, P. L.; Chen, B.H.; Yang, F.L. and Lu, Y.F. (2010): Effects of deep-frying oil on blood pressure and oxidative stress in spontaneously hypertensive and normotensive rats. *Nutrition*, 26(3): 331-336.
  48. Yener, Y. and Dikmenli, M. (2011): The effects of acrylamide on the frequency of megakaryocytic emperipolysis and the mitotic activity of rat bone marrow cells. *J. Sci. Food Agric.*, 15 91(10):1810-1813.

## Image Denoising based on Sparse Representation and Non-Negative Matrix Factorization

R. M. Farouk and H. A. Khalil\*

Department of Mathematics, Faculty of Science, Zagazig University, Zagazig Egypt, P.O. Box 44519.

\*[khalil\\_h\\_a@yahoo.com](mailto:khalil_h_a@yahoo.com)

**Abstract:** Image denoising problem can be addressed as an inverse problem. One of the most recent approaches to solve this problem is sparse decomposition over redundant dictionaries. In sparse representation we represent signals as a linear combination of a redundant dictionary atoms. In this paper we propose an algorithm for image denoising based on Non Negative Matrix Factorization (NMF) and sparse representation over redundant dictionary. It trains the initialized dictionary based on training samples constructed from noised image, then it search for the best representation for the source by using the approximate matching pursuit (AMP) which uses the nearest neighbor search to get the best atom to represent that source. During that it alternates between the dictionary update and the sparse coding. We use this algorithm to reconstruct image from denoised one. We will call our algorithm N-NMF.

[R. M. Farouk and H.A.Khalil. **Image Denoising based on Sparse Representation and Non-Negative Matrix Factorization.** Life Science Journal 2012; 9(1):337-341]. (ISSN: 1097-8135). <http://www.lifesciencesite.com>. 48

**Keywords:** Sparse Representation, Image Denoising, Non-Negative Matrix Factorization, Dictionary Learning, Matching Pursuit

### 1. Introduction

Images always contaminated with noise in the image acquisition process and transmission phases, and denoising is an essential step to improve the image quality by removing the noise without affecting the important image features as much as possible. Commonly, noise removal has been done by using many denoising schemes, from the earlier smoothing filters like adaptive Wiener filter to the frequency domain denoising methods (Gonzalez and Woods 2002) to the lately developed methods which uses multiscale and directional transformations like wavelet, curvelet and ridgelet (Jean-Luc, Candes et al. 2002; Chen and Kegl 2007; Liu and Xu 2008; Sveinsson, Semar et al. 2008)

The success of the wavelet-based models is due to the tendency of images to become sparse in the wavelet domain, which implies that the image can be represented by using a small subset of the wavelet coefficients

One of the WT drawbacks when representing an image with a rich amount of local features is that only one fixed dictionary cannot represent well all this local features and some artifacts will appear in the denoised image.

To overcome this drawback in wavelet transform, a dictionary learning methods had been proposed to learn the dictionary from the data instead of using fixed dictionary. Elad and Aharon (M.Aharon, M.Elad et al. 2006; M.Elad and M.Aharon 2006) proposed sparse redundant representation and K-SVD based denoising algorithm by training a highly over-complete dictionary. Foi et al.(A.Foi, V.Katkovnik et al. 2007) applied a shape-adaptive discrete cosine transform (DCT) to the neighborhood, which can achieve very

sparse representation of the image and hence lead to effective denoising. Other techniques uses factorization methods like PCA and SVD to do blockwise analysis in order to conduct image denoising by modeling each pixel and its neighborhood as a vector variable(Zhang, Dong et al. 2010).

### 2. Sparse signal representation

Sparse representations for signals become one of the hot topics in signal and image processing in recent years. It can represent a given signal  $x \in R^n$  as a linear combination of few atoms in an overcomplete dictionary matrix  $A \in R^{n \times K}$  that contains K atoms  $\{a_i\}_{i=1}^K$  ( $K > n$ ). The representation of X may be exact  $x=As$  or approximate,  $x \approx As$ , satisfying  $\|x - As\|_p \leq \epsilon$ , where the vector  $s$  is the sparse representation for the vector  $x$ .

To find  $s$  we need to solve either

$$(P_0) \min_s \|s\|_0 \text{ subject to } x = As \quad (1)$$

Or

$$(P_{0,\epsilon}) \min_s \|s\|_0 \text{ subject to } \|x - As\|_2 \leq \epsilon \quad (2),$$

where  $\|\cdot\|_0$  is the  $l_0$  norm, the number on non-zero elements.

Sparse representation in the presence of noise

Suppose that we want to estimate the source signal  $z$  from the observed noised version  $x$

$$x = z + n,$$



where  $n$  is a white Gaussian noise. If we assume that the source signal  $z$  has a sparse representation over an overcomplete dictionary  $A$ , i.e.

$$z = As,$$

where  $S$  is the sparse representation of  $z$  over the dictionary  $A$ , then the problem can be formulated as in equation (2).

In this paper we use an algorithm for solving this problem. Our algorithm likes the known K-SVD algorithm but instead of using the SVD decomposition for dictionary atoms update and the Orthogonal Matching Pursuit (OMP) for sparse representation for the data matrix, we use the Non-Negative Matrix Factorization the dictionary atoms update and the Approximate Matching Pursuit the sparse representation for the data matrix. Also we choose the Gabor dictionary as an initial dictionary instead of the DCT dictionary used on the K-SVD.

### 2.1 Approximate Matching Pursuit

Given an input signal  $x \in R^M$ , and a dictionary,  $A \in R^{M \times K}$ , we want to find a vector of coefficients  $s \in R^K$  that minimizes  $\|x - As\|_2$ . The approximate matching pursuit (AMP) algorithm is described in Algorithm 1. This algorithm is similar to the orthogonal matching pursuit algorithm (OMP) except that it addresses the main computational bottleneck for large dictionaries by using nearest neighbor search by allowing any adequately near neighbor to be selected as a component instead of compute a large amount of inner product.

#### Algorithm 1. Approximate Matching Pursuit

-Input: dictionary  $A = [a_1, a_2, \dots, a_K] \in R^{M \times K}$ ,  
data  $x \in R^M$ .  
-Initialization: Let  $r = x$ ,  $s = 0$ ,  $L = \emptyset$ ,  $err = x^T x$   
- While  $err > \epsilon$  do  
  - Find any  $i$  such that  $a_i$  and  $r$  are Near Neighbors  
  -  $L = L \cup i$   
  - Solve  $s_i = \arg \min_{s_i, i \in L} \|x - \sum a_i s_i\|$   
  -  $r = x - \sum_{i \in L} a_i s_i$   
-End while  
-Output  $S$

### 3. Non-Negative Matrix Factorization

Factorization the data into simple, fundamental factors allows humans to identify the most meaningful components of data. Many real-world data are

nonnegative and the corresponding hidden components have a physical meaning only when nonnegative. In practice, both nonnegative and sparse decompositions of data are often either desirable or necessary when the underlying components have a physical interpretation. For example, in image denoising, involved variables and parameters may correspond to pixels, and nonnegative sparse decomposition is related to the extraction of relevant parts from the images (Lee and Seung 1999), (Lee and Seung 2001).

The basic NMF problem can be stated as follows:

Given a nonnegative data matrix  $X \in R^{I \times T}$  (with  $x_{it} \geq 0$  or equivalently  $X \geq 0$  and a reduced rank  $J$  ( $J \leq \min(I, T)$ ), find two nonnegative matrices  $A = [a_1, a_2, \dots, a_K] \in R^{I \times K}$  and  $S = B^T = [b_1, b_2, \dots, b_J] \in R^{K \times J}$  which factorize  $X$  as well as possible, that is  $X = AS + E = AB^T + E$ , where the matrix  $E \in R^{I \times J}$  represents approximation error.

### 4. Image denoising based on N-NMF

In this section, we introduce our N-NMF, which uses Nearest Neighbor search with the Nonnegative Matrix Factorization for image denoising. We choose the Gabor dictionary as an initial dictionary for some reasons. Firstly, choosing Gabor functions allows us to avoid some of the artificial block edge effects of the DCT basis, which used in the K-SVD, since Gabor functions tend to decay smoothly at the edges. Separability is another nice property, since it reduces the computation necessary to perform the matching search (Neff and Zakhov 1995). The other reason is that the Gabor dictionary gives a recovery rate higher than the DCT dictionary (Schnass and Vandergheynst 2008). We generate an initial dictionary  $A$  of size  $M \times K$  ( $K \gg M$ ) from the Gabor basis functions. For a noised image of size  $M \times M$  we generate blocks of size  $\sqrt{M} \times \sqrt{M}$  by using a sliding window moving over the image, and then each block is used as a column of the data matrix  $X$ , which used after that for learning the dictionary. Then we use the N-NMF algorithms, which alternate between the sparse representation of the data with fixed dictionary and updating the dictionary with fixed representation to get the best dictionary to represent the important component in the image. At the end we use the learned dictionary to reconstruct the source image.

#### Algorithm 2. N-NMF algorithm.

1. Initialization: Set an overcomplete dictionary  $A = [a_1, a_2, \dots, a_K] \in R^{M \times K}$  from the Gabor wavelet basis (GW) s.t.  $\|a_k\| = 1$  for all  $k$ .
2. Repeat until met the error goal
  - Sparse coding: find the sparse representation  $S = [s_1, s_2, \dots, s_N]$  for data matrix  $X = [x_1, x_2, \dots, x_N]$  based on the fixed dictionary  $A$  by using the approximate matching pursuit algorithm (AMP).  
For each column  $i=1, 2, \dots, N$  solve  

$$\hat{s}_i = \arg \min_{s_i} \|s_i\|_0 \text{ s.t. } \|x_i - A s_i\| \leq \varepsilon$$
  - Dictionary update: update the dictionary atoms while fixing the data matrix  $X$  and the sparse representation  $S$  by using the Nonnegative Matrix Factorization (NMF) for the overall representation error.
3. Reconstruction: reconstruct the denoised image  $I_d = A \hat{S}$

## 5. Experiments and Results

In this work, we used an overcomplete Gabor dictionary as an initial dictionary of size 64x256

generated by using Gabor filter basis of size 8x8, each basis was arranged as an atom in the dictionary. The dictionary was learned by alternating between sparse coding with the current dictionary and dictionary update with the current sparse representation. For doing that, we use the N-NMF algorithm and the approximate matching pursuit. We applied the algorithm to Lena image (as in Fig. 1), Barbra image and a face from the ORL database of faces (first face in the s1 set as shown in Fig. 2), which can be found in the following link (<http://www.cl.cam.ac.uk/research/dtg/attarchive/facedatabase.html>).

The results showed that using the overcomplete Gabor dictionary with the nonnegative matrix factorization to learn dictionaries for sparse representation gave a good results. We used that method for image denoising and evaluate our method by calculating the PSNR and compare our results with the K-SVD methods, which showed that our method gave better results over the K-SVD especially with low level noise energy. Also the approximate matching pursuit gave a fast computation compared to the orthogonal matching pursuit used in the K-SVD algorithm.



Fig. 1. (a) The original image. (b) The noised image by adding Gaussian noise with sigma=30. (c) The denoised image by using N-NMF algorithm and (d) the denoised image by using K-SVD.

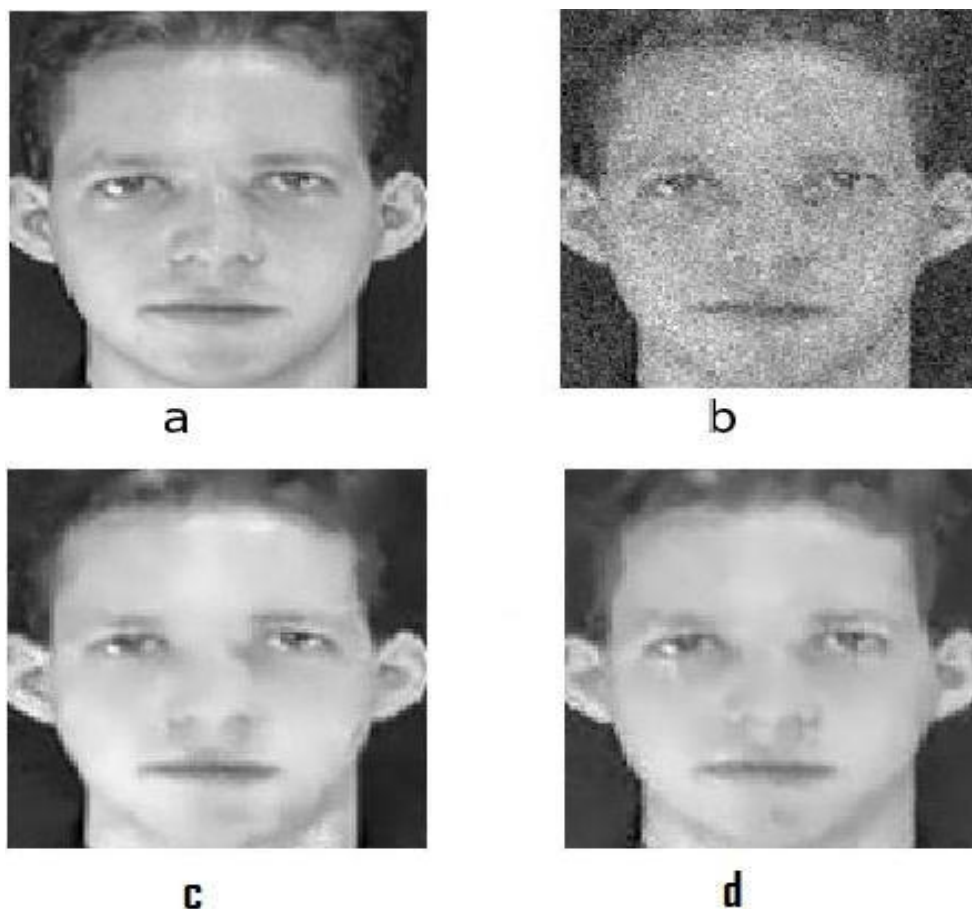


Fig. 2. (a) The original image. (b) The noised image by adding Gaussian noise with  $\sigma=20$ . (c) The denoised image by using K-SVD and (d) the denoised image by using N-NMF algorithm.

**Table 1.** The PSNR computed for 3 images with different noise variance level (sigma).

Sigma	Face		Lena		Barbara	
	KSVD	N-NMF	KSVD	N-NMF	KSVD	N-NMF
10	35.5636	38.8481	33.3948	37.0749	32.9430	36.5061
15	33.2755	35.0193	31.1033	32.6425	30.6654	32.0532
25	31.0559	32.2762	28.4547	28.8607	27.7425	27.8119
30	27.2468	27.5401	27.2819	27.5758	26.6532	26.5589

## 6. Discussion and Conclusion

In this paper, we address the image denoising problem based on sparse coding over an overcomplete dictionary. Based on the fact that both nonnegative and sparse decompositions of data are often either desirable or necessary when the underlying components have a physical interpretation, which implies on real images. We presented an algorithm N-NMF, which used the technique of learning the dictionary to be suitable for representing the important component in the image by using the nonnegative matrix factorization technique for updating the dictionary in the learning process and using approximate matching pursuit algorithm for finding the sparse coding of the data based on the

current dictionary. Experimental results show satisfactory recovering of the source image. Future theoretical work on the general behavior of this algorithm is on our further research agenda.

### Corresponding author

H. A. Khalil  
Department of Mathematics, Faculty of Science,  
Zagazig University, Zagazig P.O. Box 44519, Egypt.  
[khalil\\_h\\_a@yahoo.com](mailto:khalil_h_a@yahoo.com)

### References

4. A.Foi, V.Katkovnik, et al. (2007). "Pointwise shape-adaptive DCT for high quality denoising

- and deblocking of grayscale and colorimages." IEEE Transaction on Image Processing **16**(5).
5. Chen, G. Y. and B. Kegl (2007). "Image denoising with complex ridgelets." Pattern Recognition **40**: 578-585.
  6. Gonzalez, R. C. and R. E. Woods (2002). Digital Image Processing, second ed., PrenticeHall, Englewood Cliffs, NJ.
  7. Jean-Luc, S., E. J. Candes, et al. (2002). "The curvelet transform for image denoising." IEEE Transactions on Image Processing **11**: 670-684.
  8. Lee, D. D. and H. S. Seung (1999). "Learning of the parts of objects by non-negative matrix factorization." Nature **401**: 788-791.
  9. Lee, D. D. and H. S. Seung (2001). "Algorithms for Nonnegative Matrix Factorization." Advances in Neural Information Processing Systems **13**: 556-562.
  10. Liu, Z. and H. Xu (2008). Image Denoising with Nonsampled Wavelet-Based Contourlet Transform. Fifth International Conference on Fuzzy Systems and Knowledge Discovery: 301-305.
  11. M.Aharon, M.Elad, et al. (2006). "The K-SVD: an algorithm for designing of overcomplete dictionaries for sparse representation." IEEE Transaction on Signal Processing **54**(11): 4311-4322.
  12. M.Elad and M.Aharon (2006). "Image denoising via sparse and redundant representations over learned dictionaries." IEEE Transaction on Image Processing **15**: 3736-3745.
  13. Neff, R. and A. Zakhor (1995). Matching Pursuit Video Coding at Very Low Bit Rates Data Compression, Snowbird, UT, USA.
  14. Schnass, K. and P. Vandergheynst (2008). "Dictionary Preconditioning for Greedy Algorithms." IEEE TRANSACTIONS ON SIGNAL PROCESSING **56**(5): 1994-2002.
  15. Sveinsson, J. R., Z. Semar, et al. (2008). "Speckle Reduction of SAR Images in the Bandlet Domain." IEEE International Geoscience and Remote Sensing Symposium: 1158-1161.
  16. Zhang, L., W. Dong, et al. (2010). "Two-stage image denoising by principal component analysis with local pixel grouping." Pattern Recognition **43**: 1531-1549.

1/25/2012

## Gut Histology of Malaysian River Catfish, *Mystus nemurus* (C&V) Larvae

Ghada Ahmed El Hag<sup>1</sup>, Mohd Salleh Kamarudin<sup>2</sup>, Che Roos Saad<sup>2</sup> and Siti Khalijah Daud<sup>3</sup>

<sup>1</sup>Department of Fisheries Science, Faculty of Agricultura Technology and Fisheries Science, University of Alneelain, Khartoum, Sudan.P.O.Box:12702.

<sup>2</sup>Faculty of Agriculture, Department of Aquaculture, University Putra Malaysia,

<sup>3</sup>Faculty of Science Universitiy Putra Malaysia, 43400 UPM, Serdang, Selangor D. E., Malaysia  
[ghahmed@yahoo.com](mailto:ghahmed@yahoo.com)

**Abstract:** For the successful weaning of *M. nemurus* larvae, the development of gut histology was observed. The eggs hatched two days after fertilization (2 daf) and most of the larvae hatched within 2-4 daf. The commencement of external feeding start on the 4 days post-hatch (dph). Fish larvae are characterized by digestive system and diets that differ from adults. Larvae undergo a pattern of trophic ontogeny, changing with increasing size, and these changes result in differences in digestive requirements. The histological development of the gut of *M. nemurus* larvae were investigated from hatching until 21dph using a compound microscopy. During the yolk sac period, the gut is a simple, straight, undifferentiated tube throughout its length. By 4-5 dph the gut differentiated to the oesophagus, stomach, and intestine. At first feeding, the larval gut is functional, but is structurally and functionally less complex than that of adults. By the 13 dph the larvae attained four tissue layers arrangement.

[Ghada Ahmed El Hag, Mohd Salleh Kamarudin, Che Roos Saad and Siti Khalijah Daud. **Gut Histology of Malaysian River Catfish, *Mystus nemurus* (C&V) Larvae.** Life Science Journal 2012;9(1):342-347]. (ISSN: 1097-8135).  
<http://www.lifesciencesite.com>. 49

**Key words:** Malaysian river catfish; larvae; gut histology; *Mystus nemurus*.

### 1. Introduction

Malaysian tropical catfish, *Mystus nemurus* (C & V) or “baung” as locally known, is an edible species preferred by all ethnic races in Malaysia (Khan *et al.*, 1990). Eight species of *Mystus* found in Malaysian waters are *Mystus nemurus*, *M. nigriceps*, *M. planiceps*, *M. micranthus*, *M. wyckii*, *M. guhio*, *M. wolffii* and *Mystus bimaculatus* (Lim *et al.*, 1993). *Mystus nemurus* is the most popular, and is the largest of local *Mystus* (Smith, 1945). The species has a wide distribution ranging from the East Indies to Asiatic mainland in Peninsular Malaysia, Indochina and Thailand. The fish is a bottom feeder and feeds extensively on a wide range of food items which include teleosts, crustaceans, benthic invertebrates and detrital materials (Khan, 1987). *Mystus nemurus* are monogamous and sexes cannot be differentiated in fishes less than 18 cm in sizes (Khan *et al.*, 1990).

Recently, the interest has been growing rapidly in both its intensive and extensive domestication (Khan, *et al.* 1990). However, inadequate seed supply coupled with relatively high fingerling prices limit its production. Large scale of rearing of *Mystus nemurus* larvae has yet to be refined in terms of husbandry techniques and nutritional requirements of the larvae.

Fish larvae are the smallest autonomous active feeding vertebrates (Wieser, 1995). The nutrition of larval fish is one of the dominant factors influencing their survival in larviculture (Jancarić, 1964 cited in Kolkovski *et al.*, 1993). There is still much to be discovered about the way in which fish larvae utilize the food present in an aquaculture environment.

Fish larvae usually are very different from their adult counterparts by having simpler digestive systems, and the development of alimentary canal of fish larvae is morphologically, histologically and physiologically less elaborate than that of adult fish (Govoni *et al.*, 1986 and Osman, *et al.* 2008). However, there is a diverse diversity in the morphology and histology of the gut between larvae and adult fish of the same species and between different species of fish. Despite simple characteristics of gut, the larvae require suitable and sufficient food to grow better during this period (Watanabe and Kiron, 1994).

Although live food are still the most reliable, artificial diets have been used in attempts to establish the nutritional requirements of larval fish and to obtain cheap, well defined diets for their intensive rearing (Munilla-Moran *et al.*, 1990). At weaning time, the gut of fish larvae is simple and the digestive glands and enzyme production are not fully developed (Holt, 1992; Kamali, *et al.* 2006 and Camacho, *et al.* 2010). Hogendoorn (1980) and Watanabe and Kiron (1994) reported that poor growth and survival rate are usually shown when the larvae are exclusively fed on dry diet.

*M. nemurus* adult fish is an omnivorous, europhagus feeder and indwells ecological regions (Khan, 1987). As a “new” indigenous species in Malaysian aquaculture, much information related to the feeding at larval stage is still unknown. The present study was conducted to observe the histological changes of the gut of *M. nemurus*. This information will provide a good understanding of the fish larval digestive system that could facilitate the determination of suitable larval feed and weaning time.

## 2. Materials and Methods

The samples for histological study were fixed in Bouin's fixative for 24 hour, then washed and stored in 70% alcohol. The tissue processing was done by an automatic tissue processor (Shandon Citadel 1000) for 22 hrs (Table 1) and subsequently embedded in paraffin wax. Five species/samples were put into blocking and cooling for at least 10 mins. Sample blocks were placed on a microtome holder, trimmed and sectioned at 5  $\mu$ m thickness. Sections were spread in water bath and collected onto clean glass slides. The slides were dried at 40° C on a hot plate for 10 mins. Slides were stained with haematoxylin and eosin (Harris, 1972) as shown in Table 2. Dry slides were mounted with neutral mounting medium. Samples are then viewed under a compound microscopy (Zeiss Axioskop 50).

**Table (1):** Tissue processing, by an Automatic Tissue Processor.

	Solution	Time
1	70% Alcohol	2 hrs
2	90% Alcohol	2 hrs
3	Isopropyl Alcohol I	1 hrs
4	Isopropyl Alcohol II	1 hrs
5	Isopropyl Alcohol III	2 hrs
6	Isopropyl Alcohol IV	2 hrs
7	Isopropyl Alcohol V	2 hrs
8	Chloroform I	5 hrs
9	Chloroform II	30 mins
10	Paraffin Wax I	3 hrs
11	Paraffin Wax II	1h-30 mins
	Total time	22 hrs

**Table. (2):** H & E staining procedure.

	Solution	Time
1	Xylene	2 mins
2	Xylene	2 mins
3	Alcohol 100%	2 mins
4	Alcohol 100%	2 mins
5	Rinse in water	30 sec
6	Haematoxylin	15 mins
7	Rinse in water Acid Alcohol%	3 dips
8	Rinse in running water	7 mins
9	Alcohol 100%	2 mins
10	Alcohol 100%	2 mins
11	Eosin	5 mins
12	Alcohol	2 mins
13	Alcohol	2 mins
14	Alcohol	2 mins
15	Xylene	2 mins
16	Xylene	2 mins

## 3. Results

Newly hatched *M. nemurus* larvae have a straight simple, undifferentiated tube-like gut dorsally located to the yolk sac. The gut was histologically undifferentiated along its length. The anus was opened at 3 days post harvest (dph). At 4-5 dph, the digestive tract was differentiated into the oesophagus, stomach, and intestine. On 13 dph it attained the four tissue layers arrangement in adult vertebrates which is a characteristic of the digestive tract lining.

### Oesophagus

At 5 dph, the oesophagus (Fig.1) can be distinguished from other regions by the appearance of epithelial cells with numerous goblet cells (G). The layers of the oesophagus consist of lumen, mucosa (M), submucosa (S), muscularis (MU) and serosa (SE). The muscularis was formed from the striated circular muscle. The goblet cells were also arranged in the posterior and mid region of the epithelial fold. The development of the mucosa was first observed on the 7 dph (Fig 2). In various stages of development, the mucosa was not well separated from the submucosa. Both lamina propria and submucosa were made up of fibrous connective tissue. The mucosa of the oesophagus consists of stratified squamous epithelium with goblet cells and this became fully developed on 7 dph. From 7 dph, the epithelium fold increased in length and size with the increase in the number of goblet cells. These cells were scattered all over the epithelium with the growth of larvae and increased in fold length (Fig. 3). On 13 dph, the muscularis has two layers; the inner longitudinal muscle layer and outer circular layer. The longitudinal muscle layer was connected to the submucosa more than to the muscularis. Four tissue layers of the oesophagus appeared on the 13 dph (Fig. 4). Some blood vessels appeared in submucosa and serosa at 15 dph (Fig. 5).

### Stomach

At 5 dph, the stomach became differentiated from the other region of the gut. The mucosa which was attached to the connective lamina propria was formed by an epithelium. The epithelium was made up of columnar cells and arranged in a single layer (Fig 6). By 9 dph (Fig. 8-9) these cells began to differentiate into glandular cells and became well developed by 13 dph (Fig. 10).

### Anterior stomach

On 5 dph the larval gastric epithelium formed small folds. The mucosa consisted of simple columnar cells arranged in a single layer (Fig. 6). A number of gastric glands lay between the tunica propria and the gastric epithelium. Submucosa consists of fibrous connective tissue and muscularis formed in circular layers. The serosa comprised a thin layer of loose connective tissues. On the 7dph, the

stomach (Fig. 7) appeared to be more fully developed and the thickness of the muscularis increased. The fold and numbers of gastric glands increased with growth.

In this region, there was no gastric gland and the mucosa was thinner than that of the fundic stomach. The lamina propria was made of thick connective tissue. By 5 dph, the muscularis was formed in thick circular layers. The thickness of the muscularis increased on the 7 dph. On 9 dph, the lamina propria (L) appeared to be more distinguished on the posterior region of the stomach (Fig. 9). The serosa was composed of a thin layer of connective tissue fibers. On 13 dph, the stomach had four tissue layers and some blood vessels appear in the serosa and submucosa.

### Intestine

The intestinal region became differentiated from the the rest of the digestive tract by the presence of tall simple columnar cells with goblet cells at 5 dph (Fig. 11). The muscularis was made of a smooth circular layer. The mucosa of interior intestine consisted many unbranched villi, each villus contains two types of cells, the simple columnar epithelial cells with a distinct centrally basal nucleus and goblet cells (Fig. 12-13). The folds of the mucosa of posterior intestine were less branching. More goblet cells were located on the anterior part. The circular layer was more distinguished on 13 dph (Fig. 14) and the intestine became fully developed.



**Fig. 1:** Longitudinal section of the oesophagus on 5 dph. (Bouin's; H&E; X320).

M=Mucosa Mu=Muscularis S=Submucosa SE=Serosa  
G=goblet cell.



**Fig. 2:** Longitudinal section of the oesophagus on 7 dph. (Bouin's; H&E; X285).



**Fig. 3:** Longitudinal section of the oesophagus on 9 dph. (Bouin's; H&E; X322).  
L= Lamina propria



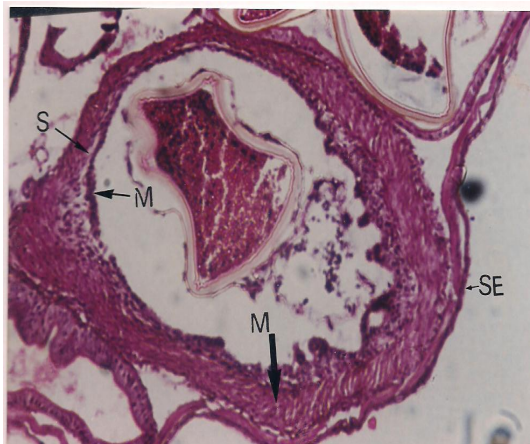
**Fig. 4 :**Longitudinal section of the oesophagus on 13 dph. (Bouin's; H&E; X311).



**Fig. 5 :** Longitudinal section of the oesophagus on 15 dph. (Bouin's; H&E; X281).



**Fig. 6:** Longitudinal section of the stomach on 5 dph. (Bouin's; H&E; X285)  
GS= Gastric gland



**Fig. 7:** Longitudinal section of the stomach on 7 dph. (Bouin's; H&E; X400).

#### 4. Discussion

The development of the digestive system of *M. nemerus* larvae during the yolk sac stage similar to most larval fish (Mahr *et al.*, 1983; Ferraris *et al.*, 1987; Verreth *et al.*, 1992; Zambonine and Cahu, 2001; Guimaraes, *et al.* 2009 and Ramezani-Fard, *et al.* 2011) probably because larval fish require only the most rudimentary system for yolk resumption. This system would be developed to adapt to the feeding habits of the fish during different development stages (Ferraris *et al.*, 1987; Klassen and Peake, 2008 and Guimaraes, *et al.* 2009). The differentiation of *M. nemerus* gut occurred after the yolk completely resorbed in 3 dph.

An early development of oesophagus may be important at the onset of the first feeding and is essential for other functions such as osmoregulation. If the function of esophagus is primarily digestive, the mucus may facilitate the movement of food and the mucosal folds would allow for extension during food consumption or increase the area for digestive activities. The development of oesophagus folds increased from 7 dph with the larval growth. This may be due to the start of exogenous feeding. Increase in the luminal area of the oesophagus is due to development of complex folds (Meister *et al.*, 1983).

Taste buds were not detected in the oesophagus of *M. nemerus* larvae. This suggested that the larvae may not be as selective on their food as other species (Reifel and Travill, 1977; Sis *et al.*, 1979; Hirji, 1983). The arrangement of inner longitudinal and outer circular layers of the muscularis in the oesophagus of *M. nemerus* (13 dph) different from the rest of the digestive tract similar to those of other larval fish (Lien, 1967; Ferraris *et al.*, 1987 Guimaraes, *et al.* 2011). In *M. nemerus* larvae, the inner longitudinal muscle seemed to be embedded in the submucosa similar to that seen in the perch larvae (Hirji, 1983). In various stages of development, the mucosa was not well separated from the submucosa because the lamina propria cannot be differentiated from submucosa.

The development of the stomach occurred following the complete yolk resorption 4-5 dph, and continued to developed by 7 dph. The differentiation of both fundic and pyloric region was similar to those of most fish larvae (Tanaka, 1973; Lopez, 1982; Verreth *et al.*, 1992 and Osman, *et al.* 2008). The appearance of the gastric glands on 7 dph indicated the presence of gastric enzymes.

The mucosa of the anterior or fundic stomach composed primarily of two functional layers. Fundic stomach is the only region in the digestive tract where non-acidic mucopolysaccharides are secreted (Kapoor *et al.*, 1976). The authors noted that the mucopolysaccharides may serve to protect these cells from auto-digestion and enzymes produced by the gastric glands. The number of gastric glands increased in *M. nemurus* with the larval growth. This means the secretion of enzymes from this region should also increase with larval development. The development of the posterior or pyloric stomach was clearly observed on 7dph, suggesting that the onset of mechanical



digestion may be related to the beginning of exogenous feeding. The mucosal cell lining on the lumen of the pylorus was much thicker than those in the fundic stomach. The absence of gastric gland in the pylorus of milkfish may be due to the pylorus may not contribute enzymes or hydrochloric acid for further chemical digestion but may only serve to facilitate food digestion by mechanical means (Reifel and Travill, 1977).

The appearance of pepsin in *M.nemurus* larvae was only observed from 4dph i.e.at the start of exogenous feeding (Kamarudin, 1999). The absence of structure and function of a fully developed stomach during the first 3 days of exogenous larval feeding of African catfish, *Clarias gariepinus* (Burchell) which will limit the amino acid availability of protein sources commonly used in fish feeds (Verreth *et al.*, 1992).

Since the earliest weaning time of *M.nemurus* larvae found by Eguia (1998) coincides well with the onset of gastric acid secretion, the poor survival and growth rates of *M.nemurus* larvae when fed with artificial diets at earlier feeding stages seem to be directly related to the absence of a functional stomach and sufficient pepsin digestion.

The intestine, which starts from the pyloric sphincter, is the longest single part of an alimentary canal. In *M.nemurus* larvae, there was no pyloric caeca present. The epithelium of the intestine differed from that of the stomach and the histological characteristics of intestinal epithelial cells were very similar to many other fish larvae (Ozaki, 1965; Yamamoto, 1966; Kapoor *et al.*, 1976 and Carmona, *et al.* 2010 ). In *M.nemurus* larvae, the intestinal epithelium has numerous microvilli at the luminal surface forming the brushborder, and the intestinal mucosa formed from a simple columnar epithelial cells. The appearance of brushborder which is particularly rich in enzymes would facilitate the digestive process (Welsch and Storch, 1976). The four layers of intestine appeared on 13 dph and this pattern indicated the end of the larval stages Chainabut *et al.*, (1991).

The results of this study indicated that *M.nemurus* larvae are able to accept and digest artificial feeding diets as early as at 5-7 dph i.e at the earlier developing stage of the stomach and this should lead to successful weaning. The differentiation that occurred soon after hatching would allow an early exogenous feeding. The appearance of four tissue layers of the gut on the 13 dph indicated the end of the larval period of *M.nemurus*.

#### Acknowledgment

We thank the Government of Malaysia through Intensification of Research in Priority Area (IRPA) project No. 49-01-02-04 and International Foundation Science, Sweden (IFS) grant No. A/2204-1 through University Putra Malaysia, for funding this study. Thanks also go to the staff of Aquatic Resources Technology Laboratory, Institute of Bioscience, UPM for their valuable assistance and cooperation.

#### Corresponding author

**Ghada A. El Hag**

Department of Fisheries Science, Faculty of Agricultural Technology and Fisheries Science, University of Alneelain, Khartoum, Sudan.P.O.Box:12702.

[ghahmed@yahoo.com](mailto:ghahmed@yahoo.com)

#### References

1. Al-Hussaini, A. H. 1947. The anatomy and histology of the alimentary tract of the plankton-feeder *Atherina forsali* (Ripp). *Journal of Morphology* **80**: 251-286.
2. Chainabut, S., Limsuwan, C. & Kitsawat, P. (1991). Digestive system. In *Histology of the walking catfish Clarias batrachus* (Roberts, R. J., Nash, G., eds.), pp.16-26. Thailand.
3. Camacho, S.; Carmona, R.; Liorente, J. I.; Sanz, A.; Garcia-Gallego, M.; Domezain, A.; Dominguez, N. and Ostos, M. V. 2010. *Journal of Fish Ichthyology* **27**(2): 693-700.
4. Eguia, R.V. (1998). Development of artificial diet on optimum feeding strategy for Malaysian river catfish *Myxus nemurus* (C&V) larvae. M. S.Thesis. University Putra Malaysia.
5. Ferraris, R. P., Tan, J. D. & Delacruz, M. C. (1987). Development of the digestive tract of milkfish, *Chanos chanos* (Forsskal): Histology and histochemistry. *Aquaculture* **61**, 241-257.
6. Govoni, J. J., Boehlert, G. W., and Watanabe, Y. 1986. The physiology of digestive in fish larvae. *Environmental Biology of Fishes* **16**: 59-77.
7. Guimaraes, R.J.; Satos, J. A.; Sato, Y. and Veloso-Junior, V. C. 2009. Early development stages of the catfish *Lophiosilurus alexandri steindachner*, 1877 (Pisces: Pseudopimelodidae) from the Sao Francisco River basin, Brazil. *Journal of Applied Ichthyology*. **25**,321-327.
8. Harris, J. E. 1972. The immune response of a cyprinid fish to infection of the acanthocephalan, *Pomphorhynchus laevis*. *International Journal of Parasitology* **2**: 459- 469.
9. Hirji, T. 1983. Observation on the histology and histochemistry of the oesophagus of the perch, *Perca fluviatilis* L. *Journal of Fish Biology* **22**: 145-152.
10. Holt, G.J. (1992) Experimental studies of feeding in larval Red drum. *Journal of the World Aquaculture Society* **23**(3): 265- 270.
11. Hogendoorn, H. 1980. Controlled propagation of African catfish (*Clarias lazera* C & V) III. Feeding and fry. *Aquaculture* **21**: 233-421.
12. Klassen, C. N. and Peake, S. J. 2008. Effect of diet switch timing and food source on survival and growth of lake sturgeon. *Journal of Applied Ichthyology* **24**(5): 527-533.
13. Kamali, A.; Kordjazi, Z., Nazary, R. 2006. The effect of the timing of initial feeding on growth and survival of ship sturgeon (*Acipenser nudiiventris*) larvae: a small-scale hatchery study. *Journal of Applied Ichthyology* **22**(1), 294-297.

14. Kamarudin, M. S. (1999). Current status of Baung larval nutrition. *Agro-Search* **6**(1), 4-9.
15. Kapoor, B. G., Smith, H. & Verighing, I. A. (1976). The alimentary canal and digestion in teleosts. *Advances in Marine Biology* **13**, 109-239.
16. Khan, M. S. (1987). Some aspects of the Biology of ikan Baung, *Mystus nemurus* (C & V) with references to Chenderoh Reservoir. M. S. Thesis. Universityi Pertanian Malaysia, Malaysia.
17. Khan, M. S., Ambak, M. A., Ang, K. J. & Mohsin, A. K. M. (1990). Reproduction biology of tropical catfish, *Mystus nemurus* (Cuvier and Valenciennes), in Chenderoh reservoir, Malaysia. *Aquaculture and Fisheries Management* **21**, 173-179.
18. Kolkovski, S., Tandler, A., Kissil, G. W., and Gertler, A. 1993. The effect of dietary exogenous digestive enzyme on ingestion, assimilation, growth, and survival of gilthead seabream (*Sparus auratus*, *Sparus Linnaeus*) larvae. *Fish Physiology and Biochemistry* **12**(3):203-209.
19. Lim, L. C. 1993. Larviculture of the greasy grouper *Epinephelus tauvina* F. and the brown-marbled grouper *E. fuscoguttatus* F. in Singapore. *Journal of the World Aquaculture Society* **24**:262-274.
20. Liem, K, F. 1967. Fuctional morphology of the integumentary, respiratory and digestive system of the synbranchoid fish *Monopterus albus*. *Copia* **67**: 375-388.
21. Lopez, N. 1982. Morpho-histological study on the early developmental stages of the red sea bream. M.S. Thesis. Kochi University, Japan.
22. Maher, K., Grabner, M., Hofer, R., and Moser, H. 1983. Histological and physiological development of the stomach in coregonus sp. *Archiv Fuer Hydrobiologie* **98**(3): 344-353.
23. Meister, M, F., Humbert, W., Kirsch, R., and Vivien-Roels, B. 1983. Structure and ultrastructure of the eosphagus in seawater and freshwater teleosts (Pisces). *Zoomorphology* **102**: 33-51.
24. Munilla-Moran, R., J.R. Stalk and A. Barbour (1990) The role of exogenous enzymes in digestion in cultured turbot larvae (*Scophthalmus maximus* L.) *Aquaculture*, **88** : 337-350.
25. Osman, A. G. M., Wuertz, S. W., Mekkaay, I. A., Verreth, J., Kirschbaum, F. 2008. Early development of African catfish *Clarias garipinus* (Burchell, 1822), focusing on the ontogeny of selected organs. *Journal of Applied Ichthyology* **24**(2): 187-195.
26. Ozaki, N. 1965. Some observation on the fine structure of the intestinal epithelium in som marine teleosts. *Archive Histology of Japan* **26**:23:38.
27. Ramezani-Ford, E.; Kamarudin, M. S.; Harmin, S. A.; Saad, C. R.; Abd Satar, M. K. and Daud, S. K. 2011. Ontogenic development of the mouth and digestive tract in larval Malaysian mahseer, *Tor tambroides* Bleeker. *Journal of Applied Ichthyology* **27**(3), 920-927.
28. Reifel, C, W., and Travill, A. A. 1977. Structure and carbohydrate histochemistry of the oesophagus in ten teleostean species. *Journal of Morphology* **152**: 303-313.
29. Sis, R. F., Jones, D. M., and Haensly, W, E. 1979. The microscopic anatomy of the oesophagus, stomach and intestine of the channel catfish, *Ictalurus*. *Journal of Fish Biology* **14**: 179-186.
30. Smith, H. M. 1945. The freshwater of Siam or Thailand. Smithsonian Institution, United States National Museum. Bulletin No.188.
31. Verreth, J.A.J., Torrese, E. L. S., Spacier, E. J. & Swiszen, A. V. D. (1992). The development of functional digestive enzyme the African catfish *Clarias gariepinus* (Burchell). *Journal of the World Aquaculture Society* **23**(4), 286-298.
32. Watanabe, T. and B. Kiron (1994) Prospects of larval fish dietetics. *Aquaculture* **124** : 223-251.
33. Welsch, U., & Storch, V. (1976). Coparative animal cytology and histology. Sidgwick and Jackson Limited, London, pp.199-235.
34. Wieser, W. 1995. Energetics of fish larvae, the smallest vertebrates. *Acta Physiologica Scandinavica* **154**: 279-290.
35. Yamamoto, T. 1966. An electron microscope study of the columnar epithelial cell in the intestine of freshwater teleosts: goldfish (*Carassius auratus*) and rainbow trout (*Salmo irideus*). *Zeitschrift fuer Zellforschung. Mikroskopische Anatomie* **72**: 66-87.
36. Zambonine, J.L and Cahu, C.L. 2001. Ontogeny of the gastrointestinal tract of marine fish larvae. *Compartive Biochmistery and Physiology* **130**(4):477-487.

## Epidemiology of Dysmenorrhea among Adolescent Students in Assiut City, Egypt

Eman M. Mohamed

Public Health and Community Medicine Department, Faculty of Medicine, Assiut University  
[emanmma@yahoo.com](mailto:emanmma@yahoo.com)

**Abstract:** Dysmenorrhea is the most common gynecologic complaint among adolescent females. It is the leading cause of recurrent short-term school absenteeism among them. The aim of the present study was to examine the prevalence, determinants, impact and treatment practices of dysmenorrhea among adolescent secondary school girls in Assiut city. A cross-sectional study was conducted in four secondary schools for girls in Assiut city, that were chosen randomly from a listing frame. Data were collected using a self-administered structured questionnaire about the presence, duration, severity, treatment, and impact of dysmenorrhea. To be eligible for study participation, female students must have had a period in the previous three months. A total of 845 adolescent school girls completed the questionnaire. The prevalence of dysmenorrhea was 76.1% (n = 643) (mild 26.6%, moderate 32.0%, and severe 41.4%). Dysmenorrhea was found to be significantly associated with: older age, earlier menarche, irregular or long cycle, and heavy bleeding. No limitation of activities was reported by 43% of participants with dysmenorrhea. About 39% reported missing school days due to dysmenorrhea during the 3 months prior to the survey and 30% reported missing individual classes. Activities affected by dysmenorrhea included class concentration (53.5%), sports participation (50.9%), class participation (49.9%), socializing with friends (45.3%), test-taking skills (35.6%), and homework tasks performance (35.6%). Nine percent consulted a physician and 42% saw a school nurse for help with their symptoms. Dysmenorrhea was significantly associated with school absenteeism and decreased academic performance, sports participation, and socialization with peers. In conclusion, dysmenorrhea is highly prevalent among adolescent secondary school girls and is related to school absenteeism and limitations on social, academic, and sports activities. Given that most adolescents don't seek medical advice for dysmenorrhea, health care providers should screen routinely for dysmenorrhea and offer treatment. As dysmenorrhea reportedly affects school performance, school administrators may have a vested interest in providing health education on this topic to their students.

[Eman M. Mohamed. **Epidemiology of Dysmenorrhea among Adolescent Students in Assiut City, Egypt.** Life Science Journal 2012; 9(1):348-353]. (ISSN: 1097-8135). <http://www.lifesciencesite.com>. 50

**Key words:** dysmenorrhea, adolescent girls, prevalence, impact, Egypt.

### 1. Introduction:

Dysmenorrhea is the most common gynecologic complaint and the leading cause of recurrent short-term school or work absenteeism among female adolescents and young adults<sup>(1-5)</sup>. Dysmenorrhea in adolescents is usually primary (or functional), and is associated with normal ovulatory cycles and with no pelvic pathology. While dysmenorrhea is less common during the first 2-3 years after menarche, when most of the menstrual cycles are anovulatory, it becomes more prevalent during mid and late adolescence, with the establishment of ovulatory menstrual cycles<sup>(1,3,6)</sup>.

While lower abdominal cramping is the most common dysmenorrhea symptom, many adolescents suffer from other menstruation-associated symptoms, such as vomiting, headache, fatigue, back pain, dizziness and diarrhea. Symptoms typically accompany the start of menstrual flow or occur within a few hours before or after onset, and last for the first 24-48 hours<sup>(7,8)</sup>. In approximately 10% of adolescents with severe dysmenorrheic symptoms, pelvic abnormalities such as endometriosis or uterine anomalies may be found<sup>(3,9)</sup>.

Several studies among American and Australian adolescents, have shown that adolescents with

dysmenorrhea report that it affects their academic performance and social and sports activities, a distressing finding given the availability of effective medications<sup>(1,4,5)</sup>. Potent prostaglandins and leukotrienes play an important role in generating the symptoms of dysmenorrhea<sup>(3,9)</sup>. Numerous studies have shown that non-steroidal anti-inflammatory drugs (NSAIDs), which inhibit the synthesis of prostaglandins, are highly effective in alleviating the symptoms of dysmenorrhea<sup>(10-13)</sup>.

This study was conducted to examine the prevalence, determinants, impact and treatment practices of dysmenorrhea among adolescent secondary school girl students in Assiut City, as it is the most common gynecologic disorder among female adolescents.

### 2. Subjects and Methods:

The present study was conducted in four secondary schools in Assiut city, that were chosen randomly from a listing frame representing general and technical education schools for girls. The study was a cross-sectional one and conducted during the first term of the academic year 2010-2011. The total sample (885 girl students) was distributed among

chosen secondary schools proportionate to the number of students in each. Within the school, classes were chosen randomly from the list representing the three grades of secondary education. The school obtained passive parental consents from all participants. To be eligible for study participation, female students must have had a period in the previous three months. Data were collected using a self-administered structured questionnaire about the presence, duration, severity, treatment and limitations of dysmenorrhea. Participants had 15-20 minutes to voluntarily complete the questionnaire, and they were told that their responses would remain confidential. This was followed by a reproductive health lecture. The investigator discussed simplified physiology of the menstrual cycle and menstrual hygiene, and answered student's inquiries in this regard, as well.

#### **Survey Instrument:**

The questionnaire, designed specifically for this study, included information on age, residence, drug use and menstrual history (age at menarche, premenstrual symptoms, cycle length, bleed length, regularity). It also included information concerning the severity of dysmenorrhea and its impact on school attendance, academic performance (self-perceived impact on class concentration, class participation, test-taking skills, homework tasks and grades), sports participation, socializing with peers, and performing daily activities.

Dysmenorrhea was defined as having painful menstruation during the previous 3 months, and the degree of pain was categorized as mild, moderate or severe. A visual analogue scale, dividing pain into mild, moderate and severe, was used to measure menstrual pain; this scale has well-established validity and reliability (Cronbach  $\alpha = 0.94$ )<sup>(14)</sup>.

School absence was defined as missing a half day to complete days of school and class absence was defined as missing individual classes because of dysmenorrhea during the previous 3 months. In addition, the questionnaire included items about treatment used by participants for dysmenorrhea and consultations sought for relief of symptoms.

#### **Statistical Analysis:**

Female students who had not had a period in the previous 3 months ( $n = 40$ ) were excluded from the data analysis. Data analysis was done using the statistical software package for the social sciences (SPSS), version 11.0. Descriptive statistics (frequency, percentage, mean and standard deviation) were used to determine mean age of participants, age at menarche, cycle length, bleed length, frequency of associated symptoms, prevalence and treatment of dysmenorrhea, and activities affected by this condition. Tests of significance (t-test and  $\chi^2$  test) were used to detect association between different variables and dysmenorrhea. A p-value  $<0.05$  was considered statistically significant. Associations between the level

of menstrual pain and activities affected by menstrual pain (school, homework, class participation, class concentration, taking tests, sports participation and going out with friends) were analyzed using odds ratio (OR) with 95% confidence interval (CI). Associations between the level of menstrual pain and the therapeutic options were also examined using OR with 95% CI.

#### **3. Results:**

A total of 845 adolescent secondary school girls completed the questionnaire. The mean age of the participants was  $16.0 \pm 1.5$  years, and the mean age at menarche was  $13.6 \pm 1.3$  years.

#### **Prevalence and determinants of dysmenorrhea:**

The prevalence of dysmenorrhea was 76.1% ( $n = 643$ ); of these, 26.6% described their menstrual pain as mild, 32.0% as moderate and 41.4% as severe (figure 1). Among adolescents with dysmenorrhea 92.1% ( $n = 592$ ) reported the duration of their menstrual cramps as 48 hours or less.

Dysmenorrhea was found to be significantly ( $P < 0.05$ ) associated with older age, earlier menarche, longer cycle length and bleed length, heavy bleeding and irregular cycle. Preparation for menarche, a psychologic variable, was not significantly associated with dysmenorrhea (table 1).

Among participants reporting cramps during menstruation, 70.0% indicated nervousness, 38.9% fatigue, 59.4% back pain, 42.9% headache, 53.8% irritability, 39.3% dizziness, and 38.3% depression. These symptoms were significantly more frequent among adolescents suffering from dysmenorrhea than their counterparts reporting no dysmenorrhea (table 2).

#### **Impact of dysmenorrhea on academic, sports and social activities:**

Among participants with dysmenorrhea, 53.5% indicated that dysmenorrhea limited their class concentration; 50.9% sports participation; 49.9% class participation; 45.3% going out with friends; 35.6% test-taking skills, 35.6% homework tasks performance. About 39% reported missing school days and 30% reported missing individual classes due to menstrual cramps during the previous 3 months (table 3). Among participants reporting school absence, 45% reported missing one half to 1 day of school, 38% reported missing 2 to 3 days, and 17% reported missing more than 4 days. The rate of school absenteeism was 53% among participants reporting severe menstrual pain compared with 22% among those with mild menstrual pain.

A significantly greater proportion of participants with severe menstrual pain reported school absenteeism, decreased academic performance, and limited socialization with friends and sports participation than those with mild menstrual pain ( $P < 0.01$ ) (table 3).

### Treatment used to alleviate symptoms of dysmenorrhea:

The participants with dysmenorrhea reported using multiple treatments to relieve their symptoms: medications (56%), rest (49%), hot tea (26.1%), herbal drinks (20.1%), heating pad (14.9%), and exercise (7.0%) (table 4).

A greater proportion of participants reporting severe menstrual pain used medications (OR, 4.9; 95% CI, 2.3–8.1), rest (OR, 3.3; 95% CI, 1.9–5.9), herbal drinks (OR, 3.2; 95% CI, 1.8–5.7), heating pad (OR, 2.9; 95% CI, 1.6–6.4), tea (OR, 2.6; 95% CI, 1.4–4.0), or physician consultation (OR, 2.1; 95% CI, 1.1–4.8) than those reporting mild menstrual pain. Among participants with dysmenorrhea who reported taking medications, 73% indicated that they treated

themselves without medical prescription as they knew the medications to alleviate their symptoms of dysmenorrhea.

Sixty-nine percent of participants with dysmenorrhea reported that they either did not think or did not know whether a physician could help them and 31% thought that a physician could help them with their menstrual symptoms. Overall, 42% of the participants with dysmenorrhea consulted the school nurse during the previous 3 months but 81% of those who visited the school nurse reported no relief from this visit. In contrast to the 42% school nurse consultation rate, only 9% consulted a physician for help; this rate increased to 14% among participants reporting severe menstrual pain.

Table (1): Menstrual history of secondary school girls participating in the study, Assiut city, 2010.

Variables	Dysmenorrhea N = 643	No Dysmenorrhea n = 202	P-value
Age in years	16.4 ± 1.15	15.5 ± 1.20	0.001
Age at menarche	13.4 ± 1.12	13.7 ± 1.17	0.01
Cycle length	29.4 ± 3.58	28.1 ± 2.35	0.001
Bleed length	5.2 ± 1.10	4.3 ± 1.14	0.001
Menstrual flow			0.001
Scanty	170 (26.4%)	81 (40.1%)	
Normal	206 (32.0%)	66 (32.7%)	
Heavy	267 (41.5%)	55 (27.2%)	
Regularity			0.001
Regular	269 (41.8%)	116 (57.4%)	
Irregular	283 (44.0%)	52 (25.7%)	
Variable	91 (14.2%)	34 (16.8%)	
Preparation for menarche			0.612
Yes	222 (34.5%)	74 (36.6%)	
No	421 (65.5%)	128 (63.4%)	

Age, cycle length and bleed length are presented as: mean ± standard deviation.

Table (2): Menstruation-associated symptoms among adolescent school girls.

Symptoms	Dysmenorrhea		No dysmenorrhea		P-value
	No.	%	No.	%	
Nervousness	450	(70.0)	75	(37.1)	0.000
Irritability	346	(53.8)	72	(35.6)	0.000
Depression	246	(38.3)	51	(25.2)	0.001
Dizziness	253	(39.3)	49	(24.3)	0.000
Backaches	382	(59.4)	79	(39.1)	0.000
Legache	171	(26.6)	74	(36.6)	0.008
Fatigue	250	(38.9)	55	(27.2)	0.003
Headache	276	(42.9)	48	(23.8)	0.000
Sleeplessness	327	(50.9)	90	(44.6)	0.126
Diarrhea	148	(23.0)	39	(19.3)	0.286
Nausea / vomiting	100	(15.6)	29	(14.4)	0.737
Loss of appetite	266	(41.4)	81	(40.1)	0.806
Acne / flushing	253	(39.3)	76	(37.6)	0.680
General aching	68	(10.6)	17	(8.4)	0.423

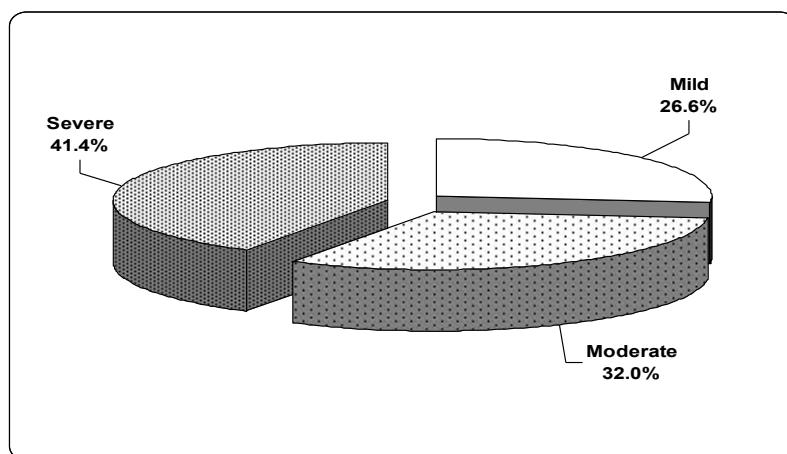


Fig. (1): Distribution of the studied adolescent students according to the level of menstrual pain (n=463).

Table (3): Association between dysmenorrhea and limited activities among adolescent girl students.

	Mild Pain *	Moderate Pain			Severe Pain		
	(n=171) %	(n = 206) %	OR (95% CI)	P-value	(n = 266) %	OR (95% CI)	P-value
School absence	22.2	34.5	1.8 (0.9-3.9)	0.01	53.0	3.9 (2.4-8.1)	0.001
Class participation	33.9	43.7	1.5 (0.8-2.7)	0.06	65.0	3.6 (1.9-6.1)	0.001
Class concentration	31.0	53.9	2.4 (0.9-3.0)	0.001	67.7	4.6 (2.2-6.9)	0.001
Test-taking skills	20.5	31.1	1.7 (0.9-3.7)	0.03	48.9	3.7 (2.1-7.6)	0.001
Sports participation	39.2	47.6	1.4 (0.8-2.5)	0.12	60.9	2.4 (1.4-4.0)	0.001
Homework tasks	21.1	30.6	1.6 (0.9-3.6)	0.045	48.9	3.5 (2.0-6.3)	0.001
Going out with friends	26.9	44.2	2.1 (1.1-3.8)	0.001	57.9	3.7 (2.1-6.5)	0.001

\* Reference group

Table (4): Treatment used by adolescent girl students to alleviate symptoms of dysmenorrhea (n=643).

Treatment options	No.	%
Medications	360	56.0
Rest	315	49.0
Tea	168	26.1
Herbal drink	129	20.1
Heating pad	96	14.9
Exercise	45	7.0

Many participants reported using multiple treatments

#### 4. Discussion:

This study revealed a relatively high prevalence of dysmenorrhea (76.1%) among adolescent school girls, which falls within the range reported by Klein and Litt<sup>(15)</sup> (59.7%) and Campbell and McGrath<sup>(2)</sup> (93%). Comparable figures were reported in similar studies, also falls within the same range, by El-Gilany et al.<sup>(16)</sup> (75%), Chiou and Wang<sup>(17)</sup> (73.3%), and Banikarim et al.<sup>(1)</sup> (85%).

The prevalence of severe dysmenorrhea (41.4%) was markedly higher than previously reported among white (23%) and African American (14%) adolescents<sup>(5,15)</sup>, but approximately similar to that reported among Hispanic female adolescents (42%)<sup>(1)</sup>. An Egyptian study in Mansoura reported a lower

prevalence of severe dysmenorrhea (14.8%)<sup>(16)</sup>. These differences could be attributed to different pain perception. Of note, participants rated their menstrual pain during the previous 3 months; the frequency and intensity of pain during each cycle may have varied and was not determined.

There was significant association of dysmenorrhea with older age, irregular or long cycles and heavy bleeding as reported by many studies<sup>(7,8,16,17)</sup>. Dysmenorrhea was significantly associated with early menarche<sup>(7,8)</sup>, as well as postmenarcheal age<sup>(18)</sup>. Preparation for menarche with health education was not a significant variable, in agreement with that reported by Klein and Litt<sup>(15)</sup>, but in contrast with Chiou and Wang<sup>(17)</sup>.

While lower abdominal cramping is the most common dysmenorrhea symptom, many adolescents suffer from other menstruation-associated symptoms. The most commonly reported symptoms were nervousness, irritability, backache, headache, dizziness and fatigue. The commonest associated symptoms reported by El-Gilany et al.<sup>(16)</sup> were fatigue, headache, backache and dizziness. Symptoms typically accompany the start of menstrual flow or occur within a few hours before or after onset, and last for the first 24-48 hours.

The school absenteeism rate in this study was higher than previously reported by Klein and Litt<sup>(15)</sup> (23.6% among African Americans and 14% among whites) and lower than that reported by Johnson<sup>(18)</sup> (45.6% among whites), but in agreement with that reported by Banikarim et al.<sup>(1)</sup> (38% among Hispanics). The variation in school absenteeism rates among these studies may be related to the existence of different cultural perception and responses to various gradients of pain<sup>(19)</sup>. However, this relationship is difficult to evaluate without studying various ethnic groups simultaneously. Also, comparing school absenteeism rates in these studies is difficult because different time frames were used in determining the former. Not surprisingly, the rate of school absenteeism was higher among adolescent school girls with severe menstrual pain than mild menstrual pain, consistent with previous findings<sup>(1,4,16)</sup>. Adolescent school girls with severe menstrual pain were nearly four times as likely to miss school, and to have limited academic performance than those with mild menstrual pain. Given these findings, school officials and school health program coordinators may benefit from considering dysmenorrhea in the context of improving their school attendance rates and academic performance of their students.

Despite the high prevalence of dysmenorrhea in adolescents, many girls either do not seek medical advice or are under-treated. The majority of adolescents used non pharmacologic methods such as rest, heat, hot drinks, or sports (mainly for distraction) to treat dysmenorrhea, consistent with previous findings<sup>(1,20)</sup>. Among participants with dysmenorrhea who reported taking medications, 73% reported self-medicating with over-the-counter pain medications without medical prescription. This figure was higher than previous study findings (30-70%) from different populations<sup>(7,21,22)</sup>. A physician consultation rate of 9% is lower than that reported in previous studies, while medication use rate of 56% is higher than previous study findings<sup>(1,4,15,16,17,18)</sup>. Alternate sources of medical advice included school nurses. A greater proportion of participants with dysmenorrhea sought help from school nurses instead of physicians, which suggests that these participants felt more comfortable seeking help from nurses, despite of the self-perceived ineffectiveness of the care received at the nurse's

office. Unfortunately, the lack of knowledge regarding the role of physicians in the treatment of this condition was alarming (69%), which may have contributed to the low physician consultation rate.

Potent prostaglandins and potent leukotrienes play an important role in generating primary dysmenorrhea symptoms. Non-steroidal anti-inflammatory drugs (NSAIDs) are the most common pharmacologic treatment for dysmenorrhea. Adolescents who restrict daily activities because of dysmenorrhea should be offered prophylactic treatment with NSAIDs. A loading dose of NSAIDs (typically twice the regular dose) should be used as initial treatment for dysmenorrhea, followed by a regular dose until symptoms abate<sup>(9-13)</sup>. In this study, about 60% of those who took medications for dysmenorrhea still indicated social and academic limitations, which suggests that these medications were an inappropriate choice or dose. The adolescent girls were unable to determine the dosage and type of medications taken for dysmenorrhea or the self-perceived effectiveness of their use. To maximize benefit from NSAIDs, health care providers may consider inquiring about the type and dose of medications that their adolescent patients are taking for their menstrual pain.

There are several limitations to this study. Secondary dysmenorrhea is rare among adolescents but this cause of menstrual pain could not be excluded because the participants were not clinically evaluated for secondary causes of dysmenorrhea. Also, participants were asked to recall menstrual and school absenteeism information for three months ago, which may have led to recall bias. In addition, the information on dysmenorrhea was obtained by self-report and could not be validated.

In conclusion, dysmenorrhea is common among adolescent population in Assiut city and leads to limitations of their social, academic and sports activities. In light of the public health importance of these social and academic limitations associated with dysmenorrhea, school administrators could play a vital role in this regard by incorporating dysmenorrhea and its treatment into health education curricula. More effective school nurse may also help alleviate the discomfort that may students experience from dysmenorrhea while in school. Also, school nurses could intervene through secondary prevention by educating students about appropriate medication use and referring to health care providers in the community or school-based clinics as needed.

#### **Corresponding author**

Eman M. Mohamed

Public Health and Community Medicine Dept., Faculty of Medicine, Assiut University, Egypt

[emanmma@yahoo.com](mailto:emanmma@yahoo.com)

**References:**

- 1- Banikarim C, Chacko MR, Kelder SH. Prevalence and impact of dysmenorrhea on Hispanic female adolescents. *Arch Pediatr Adolesc Med* 2000; 154: 1226-1229.
- 2- Campbell M, McGrath P. Use of medication by adolescents for the management of menstrual discomfort. *Arch Pediatr Adolesc Med* 1997; 151:905-912.
- 3- Harel Z. Dysmenorrhea in adolescents and young adults: Etiology and management. *J Pediatr Adolesc Gynecol* 2006; 19: 363-371.
- 4- Hillen J, Grbavac S. Primary dysmenorrhea in young western Australian women: prevalence, impact and knowledge of treatment. *J Adolesc Health* 1999; 25:40-45.
- 5- Wilson C, Keye W. A survey of adolescent dysmenorrheal and premenstrual symptom frequency. *J Adolesc Health Care* 1989; 10: 317-322.
- 6- Klein JR, Litt IF. Epidemiology of adolescent dysmenorrhea. *Pediatrics* 1981; 68: 661-665.
- 7- Andersch B, Milsom I. An epidemiologic study of young women with dysmenorrhea. *Am J Obstet Gynecol* 1982; 14:655-659
- 8- Balbi C, Musone R, Menditto A, et al. Influence of menstrual factors and dietary habits on menstrual pain in adolescence age. *Eur J Obstet Gynecol Reprod Biol* 2000; 91: 143-148.
- 9- Harel Z. Dysmenorrhea in adolescents. *Ann N Y Acad Sci* 2008; 1135: 185-195.
- 10- Mehlisch DR. Ketoprofen, ibuprofen, and placebo in the treatment of primary dysmenorrhea: a double blind cross-over comparison. *J Clin Pharmacol* 1988; 28: S29.
- 11- Mehlisch DR. Double-blind cross-over comparison of ketoprofen, naproxen, and placebo in patients with primary dysmenorrhea. *Clin Ther* 1990; 12: 398-402.
- 12- Marchini M, Tozzi L, Bakshi R, et al. Comparative efficacy of diclofenac dispersible 50 mg and ibuprofen 400mg in patients with primary dysmenorrhea. A randomized, double blind, within-patient, placebo-controlled study. *Int J Clin Pharmacol Ther* 1995; 33: 491-495.
- 13- Dawood M. Non-steroidal anti-inflammatory drugs and changing attitudes toward dysmenorrhea. *Am J Med* 1988; 84: 23-28.
- 14- Mcdowell I, Newell C. *Measuring Health- A Guide to Rating Scales and Questionnaires*. 2<sup>nd</sup> ed. New York, NY: Oxford University Press; 1996.
- 15- Klein J, Litt I. Epidemiology of adolescent dysmenorrhea. *Pediatrics* 1981; 68: 661-664.
- 16- El-Gilany AH, Badawi K, El-Fedawy S. Epidemiology of dysmenorrhea among adolescent students in Mansoura, Egypt. *East Mediterr Health J* 2005; 11 (1-2): 155-163.
- 17- Chiou MH, Wang HH. Predictors of dysmenorrhea and self-care behavior among vocational nursing school female students. *J Nurs Res* 2008; 16 (1): 17-25.
- 18- Johnson J. Level of knowledge among adolescent girls regarding effective treatment for dysmenorrhea. *J Adolesc Health Care* 1988; 9: 398-402.
- 19- Wenger A. Cultural meaning of symptoms. *Holistic Nurse Practitioner*. 1993; 7: 22-35.
- 20- Campbell MA, McGrath PJ. Non-pharmacologic strategies used by adolescents for the management of menstrual discomfort. *Clin J Pain* 1999; 15:313-317.
- 21- Johnson J. Level of knowledge among adolescent girls regarding effective treatment for dysmenorrhea. *J Adolesc Health* 1988; 9:398-403.
- 22- Campbell MA, McGrath PJ. Use of medication by adolescents for the management of menstrual discomfort. *Arch Pediatr Adolesc Med* 1997; 151: 905-911.



## Ameliorative Effects of Sildenafil in Acetic Acid-Induced Chronic Colitis in Rats

Osama M. Ahmed<sup>1\*</sup>, Alaa Afifi<sup>2</sup>, Tarek M. Ali<sup>3</sup>, Shima A. Ramadan<sup>3</sup> and Ayman M. Mahmoud<sup>1</sup>

<sup>1</sup>Physiology Division, Zoology Department, Faculty of Science, Beni-Suef University, Egypt

<sup>2</sup>Physiology Department, Faculty of Medicine, Cairo University, Egypt

<sup>3</sup>Physiology Department, Faculty of Medicine, Beni-Suef University, Egypt

\*Corresponding author: [osamamoha@yahoo.com](mailto:osamamoha@yahoo.com)

**Abstract:** This study aims to assess the effect of sildenafil citrate, a potent inhibitor of cyclic guanosine monophosphate (cGMP)-specific phosphodiesterase (PDE) 5, on the colon histological integrity, oxidant-antioxidant status and pro-inflammatory cytokines in a rat model of acetic acid-induced colitis. Chronic colitis was induced under light ether anesthesia by intrarectal administration of 1 ml of 5% (v/v) acetic acid (AA) in male albino rats, with a second intrarectal administration of the same dose after 16 days. Control rats received an equal volume of saline intrarectally. Experimental rats were treated orally with either sildenafil citrate (5 and 10 mg/kg/day) or saline for 3 days. Tissue samples were used for the measurement of malondialdehyde (MDA) and glutathione (GSH) levels, and glutathione peroxidase (GPx) and superoxide dismutase (SOD) activities. Blood was collected for the assessment of serum AST, ALT, creatinine, urea, tumor necrosis factor (TNF)- $\alpha$  and interleukin (IL)-1 $\beta$  levels. Obtained results revealed that in colitis group, the colonic tissue was characterized by lesions such as cystic dilatation, hemorrhage, and leukocytic infiltrations, increased lipid peroxidation with a concomitant reduction in GSH content, and decreased GPx and SOD activities. Serum hepatic and renal function parameters, TNF- $\alpha$  and IL-1 $\beta$  levels were higher in the colitis group compared to control values. Sildenafil, in a dose dependent manner, reversed these parameters nearly back to control values. In conclusion, sildenafil citrate administration to rats with chronic AA-induced colitis seems to be beneficial *via* prevention of inflammatory processes, lipid peroxidation, cytokine production and alleviation of the anti-oxidant defense system.

[Osama M. Ahmed, Alaa Afifi, Tarek M. Ali, Shima A. Ramadan and Ayman M. Mahmoud. **Ameliorative Effects of Sildenafil in Acetic Acid-Induced Chronic Colitis in Rats.** Life Science Journal 2012; 9(1):354-361]. (ISSN: 1097-8135). <http://www.lifesciencesite.com>. 51

**Key Words:** Sildenafil, Acetic acid-induced colitis, Oxidative stress, Pro-inflammatory cytokines.

### 1. Introduction

Inflammatory bowel diseases (IBD), namely ulcerative colitis and Crohn's disease are two chronic idiopathic diseases characterized by prominent intestinal inflammation (Carter *et al.*, 2004). Although the pathophysiology of IBD is not known with certainty, immunological processes and reactive oxygen species (ROS), such as peroxide anion, hydrogen peroxide (H<sub>2</sub>O<sub>2</sub>), and hypochloric acid have been proposed to contribute considerably in development of tissue injury (Fiocchi, 1998). Many other inflammatory mediators have been also related; tumour necrosis factor- $\alpha$  (TNF- $\alpha$ ) plays a prominent role and the neutralization of this cytokine is accompanied by a remarkable clinical response in patients with IBD (Colon *et al.*, 2001).

In addition, toxic oxidants are capable of destroying tissue if their rate of production exceeds the capacity of endogenous antioxidant defense mechanisms (Kruidener *et al.*, 2003). Under normal physiological conditions, antioxidant defense mechanisms protect tissues from ROS. Defense mechanisms consist of several radical scavenger and enzymes, including superoxide dismutase (SOD), catalase (CAT), reduced glutathione (GSH) and peroxidases. However, the gut is potentially vulnerable

to oxidant injury due to a low concentration of antioxidant enzymes, which are mainly localized in epithelial cells (Grisham *et al.*, 1990).

Sildenafil is a selective and potent inhibitor of cyclic guanosine monophosphate (cGMP)-specific phosphodiesterase (PDE5), which catalyzes the hydrolysis of cGMP and has a relaxant effect on the smooth muscle cells of the arterioles supplying the human corpus cavernosum (Gibson, 2001; Rosalmeida *et al.*, 2003). The data of a recent study have shown that sildenafil, acting *via* nitric oxide (NO)-dependent mechanism, prevented indomethacin-induced gastropathy, possibly through a reduction of leukocyte adhesion and maintenance of gastric blood flow (Santos *et al.*, 2005).

In the light of the above mentioned findings, this study is designed to assess the effect of two different doses of sildenafil on the extent of colon histological deteriorations, oxidant-antioxidant status and the pro-inflammatory cytokines, TNF- $\alpha$  and IL-1 $\beta$ , in a rat model of AA-induced colitis.

### 2. Materials and Methods:

#### Chemicals

Sildenafil citrate was supplied from Pfizer Inc. (Pfizer, Egypt), stored at 2-4 °C and protected from

sunlight. All other chemicals were of analytical grade and were obtained from standard commercial supplies.

### Experimental animals

Male albino rats (*Rattus rattus*) weighting about 150-180 g were used as experimental animals in the present investigation. The animals were housed in standard polypropylene cages with stainless steel good aerated covers and maintained under controlled room temperature ( $22\pm 2$  °C) with 12 h light - dark cycle and were fed a standard diet of known composition, and water *ad libitum*. The animals used in the present study were maintained in accordance with the principles and guidelines of the Canadian Council on Animal Care as outlined in "Guide for the Care and Use of Laboratory Animals" (1993).

### Induction of colitis:

After an overnight fasting, colonic inflammation was induced under light ether anesthesia by intrarectal administration of 1 ml of 5% (v/v) acetic acid in 0.9% NaCl with a 8 cm long cannula (MacPherson and Pfeiffer, 1978), with a second intrarectal administration of the same dose after 16 days. The rats in the control group were subjected to the same procedure with the exception that isotonic saline was substituted for acetic acid.

### Experimental design

The experimental animals were divided into six equal groups, each group comprising six rats designated as follows. **Group 1** served as control rats; **Group 2** was administered sildenafil at dose level of 5 mg/kg b. wt.; **Group 3** received sildenafil at dose level of 10 mg/kg b. wt.; **Group 4** served as colitis control group; **Group 5** received sildenafil at dose level of 5 mg/kg b. wt., starting 5 minutes after intrarectal administration of the second dose of acetic acid and continued for 3 days and **Group 6** received sildenafil at dose level of 10 mg/kg b. wt., starting 5 minutes after intrarectal administration of the second dose of acetic acid and continued for 3 days. At the end of the treatment period, rats were sacrificed under diethyl ether anesthesia and blood samples were collected from jugular vein. After coagulation, blood samples were centrifuged. The supernatant sera were fractioned and kept in deep freezer at  $-30$  °C until used.

### Biochemical studies:

Serum levels of the proinflammatory cytokines, TNF- $\alpha$  and IL-6, were determined by specific ELISA kits according to the manufacturer's instructions (R&D Systems, USA). The concentration of proinflammatory cytokines was determined spectrophotometrically at 450 nm. Standard plots were constructed by using standard cytokines and the concentrations for unknown samples were calculated from the standard plot.

Lipid peroxidation, reduced glutathione content, and superoxide dismutase (SOD) and glutathione peroxidase (GPx) activities were also measured in colon homogenate according to the methods of Preuss *et al.* (1998), Beutler *et al.* (1963), Marklund and Marklund (1974) and Kar and Mishra (1976), respectively. Serum AST activity (Murray, 1984), ALT activity (Murray, 1984), creatinine concentration (Young, 1995) and urea level (Kaplan, 1984) were determined using reagent kits purchased from Spinreact (Spain).

### Histopathological studies:

After scarification, decapitation and dissection, colon from each rat was rapidly excised and then perfused in saline solution. Pieces from the colon and rectum of rats of different groups were taken and fixed in 10% neutral buffered formalin for twenty four hours. Fixed organs were sent to Histopathology laboratory in Faculty of Veterinary Medicine, Beni-Suef University for further processing, blocking in wax, sectioning and staining with hematoxylin and eosin (H&E).

### Statistical analysis:

The data were analyzed using the one-way analysis of variance (ANOVA) (PC-STAT, University of Georgia, 1985) followed by LSD test to compare various groups with each other. Results were expressed as mean  $\pm$  SE and values of  $P>0.05$  were considered non-significantly different, while those of  $P<0.05$  and  $P<0.01$  were considered significant and highly significant, respectively.

### 3. Results:

The effect of sildenafil on serum TNF- $\alpha$  and IL-1 $\beta$  of normal and AA-induced colitic rats was illustrated in figures (1) and (2) respectively. In normal rats, only the higher dose (10 mg/kg b.wt.) produced a highly significant ( $P<0.01$ ) effect on serum TNF- $\alpha$  and IL-1 $\beta$  levels. In AA-induced colitic rats, both doses of sildenafil induced a highly significant ( $P<0.01$ ) decrease of TNF- $\alpha$  and IL-1 $\beta$  as compared to AA-induced colitic control rats; both doses have more or less similar effects.

Colon GSH content was highly significantly ( $P<0.01$ ) decreased in AA-induced colitis as compared to normal. The treatment of AA-induced colitic rats with the higher dose of sildenafil produced a significant ( $P<0.05$ ) improvement of the decreased GSH level while the administration of the lower dose had a non-significant effect (Fig. 3).

The administration of AA to normal rats produced a highly significant ( $P<0.01$ ) increase in colon lipid peroxidation (Fig. 4). The treatment of AA-induced colitis in rats with sildenafil citrate prevent this elevation of lipid peroxidation to great extent ( $P<0.01$ ).

SOD activity in colon exhibited a different behavioral pattern, it showed a highly significant decrease ( $P < 0.01$ ) in AA-administered rats as compared with normal (Fig. 5). This deficiency was significantly ( $P < 0.05$ ) improved in colitic rats treated with sildenafil citrate at dose level of 5 mg/kg and highly significantly ( $P < 0.01$ ) increased at the higher dose.

Glutathione peroxidase activity was highly significantly ( $P < 0.01$ ) decreased in AA-induced colitis groups when compared with normal group, as illustrated in figure (6). The treatment of colitis in rats with sildenafil citrate only at its higher dose induced a highly significant ( $P < 0.01$ ) increase in the enzyme activity as compared with the chronic induced colitis control rats. However, the lower dose of sildenafil citrate had a non-significant effect ( $P > 0.05$ ) in chronic colitic rats. Concerning one-way ANOVA, it was found that the effect between groups on colon MDA, GSH, SOD and GPx was very highly significant ( $P < 0.001$ ) throughout the experiment.

Data showing the effect on liver function parameters in serum were represented in table (1). AA administration produced a highly significant ( $P < 0.01$ ) elevation of serum AST and ALT as compared with normal rats. The treatment of chronic colitis groups with sildenafil produced a pronounced amelioration of the elevated serum AST and ALT activities. Both doses produced a highly significant ( $P < 0.01$ ) decrease of the elevated ALT activity. On the other hand, while the low dose of sildenafil produced a significant ( $P < 0.05$ ) decrease of the elevated AST activity, the higher dose induced a highly significant ( $P < 0.01$ ) decrease. The higher dose of sildenafil citrate appeared to be more potent in reducing the elevated AST and ALT activities. One-way ANOVA showed that the

effect between groups on serum AST and ALT was very highly significant ( $P < 0.001$ ) throughout the experiment.

The changes in kidney function parameters in serum as a result of treatment of acetic acid-induced colitis with sildenafil were represented in table (2). There was a highly significant ( $P < 0.01$ ) increase in serum urea concentration of AA-administered rats as compared with normal. This elevation highly significantly ( $P < 0.01$ ) decreased following sildenafil-treatment.

Data represented in this study also illustrate that serum creatinine concentration exhibited a highly significant increase ( $P < 0.01$ ) in AA-administered rats as compared with normal control group. This elevation is significantly reduced in sildenafil-treated colitic rats as compared with the colitis control group; the higher dose of sildenafil citrate seemed to be more effective in decreasing the elevated serum creatinine level in AA-induced colitic rats since its effect is highly significant ( $P < 0.01$ ).

Histopathological examination of colon sections of normal group illustrated no histopathological alterations and the normal histological structure of the mucosa, muscularis mucosa and lamina propria (Fig. 7). Colon of the chronic colitis groups showed submucosal proliferated fibrous tissue, some patches of surface erosion and loss of the superficial epithelium of mucosa and cystic dilations. In addition, there were also a leukocytic infiltrations as well as hemorrhage (Figs. 8 & 9). Sildenafil, dose-dependently, could significantly improve the inflammatory response induced by AA, however, there are still slight alterations represented by mild lymphocytic infiltration and hyperemia

**Table 1: Effect of sildenafil citrate on serum AST and ALT activities of normal and AA-induced colitic rats.**

Group	Parameter	AST (U/L)	ALT (U/L)
Normal Control		32.59 ± 1.11 <sup>bc</sup>	25.11 ± 1.32 <sup>c</sup>
Normal + Sildenafil (5 mg/kg)		30.26 ± 3.43 <sup>c</sup>	32.01 ± 1.95 <sup>bc</sup>
Normal + Sildenafil (10 mg/kg)		33.59 ± 2.69 <sup>bc</sup>	32.25 ± 0.41 <sup>bc</sup>
Chronic Colitis		69.99 ± 5.61 <sup>a</sup>	62.00 ± 4.32 <sup>a</sup>
Chronic Colitis + Sildenafil (5 mg/kg)		49.76 ± 5.64 <sup>b</sup>	38.70 ± 1.89 <sup>b</sup>
Chronic Colitis + Sildenafil (10 mg/kg)		40.25 ± 4.02 <sup>bc</sup>	31.42 ± 2.60 <sup>bc</sup>
F-Probability		P < 0.001	P < 0.001
LSD at 5%		17.59	10.45
LSD at 1%		24.81	14.65

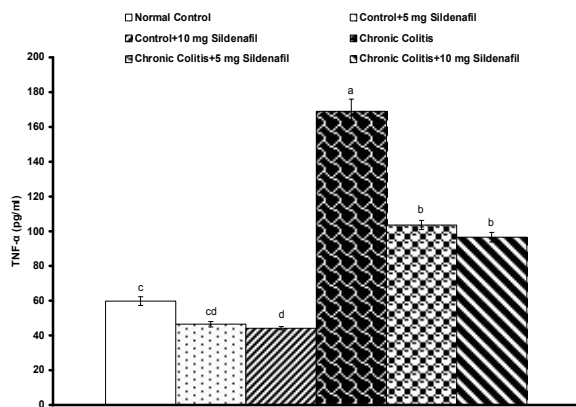
- Data are expressed as Mean ± SE. Number of animals in each group is six.

- Means, which share the same superscript symbol(s), are not significantly different.

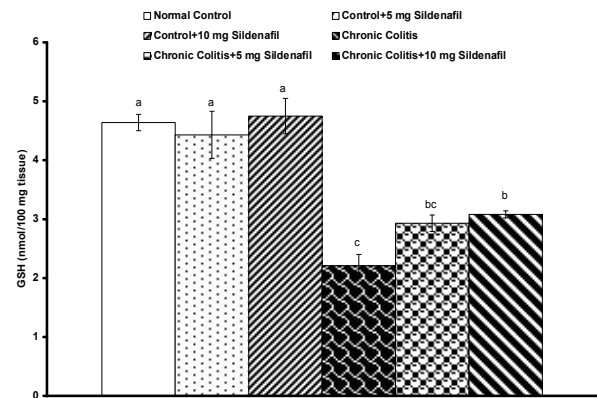
**Table 2: Effect of sildenafil citrate on serum urea and creatinine levels of normal and AA-induced colitic rats**

Group	Parameter	Urea (mg/dl)	Creatinine (mg/dl)
Normal Control		23.71 ± 1.70 <sup>b</sup>	0.62 ± 0.03 <sup>b</sup>
Normal + Sildenafil (5 mg/kg)		23.30 ± 1.34 <sup>b</sup>	0.64 ± 0.03 <sup>b</sup>
Normal + Sildenafil (10 mg/kg)		23.27 ± 1.41 <sup>b</sup>	0.57 ± 0.01 <sup>b</sup>
Chronic Colitis		61.64 ± 2.85 <sup>a</sup>	0.84 ± 0.03 <sup>a</sup>
Chronic Colitis + Sildenafil (5 mg/kg)		22.98 ± 2.31 <sup>b</sup>	0.68 ± 0.04 <sup>b</sup>
Chronic Colitis + Sildenafil (10 mg/kg)		23.86 ± 2.18 <sup>b</sup>	0.62 ± 0.03 <sup>b</sup>
F-Probability		P<0.001	P<0.01
LSD at 5%		8.48	0.13
LSD at 1%		12.39	0.18

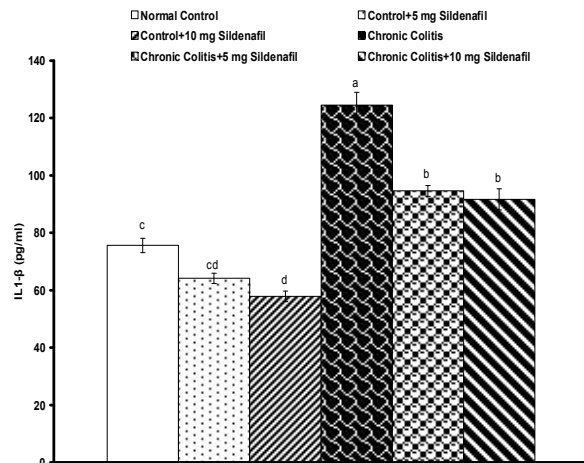
- Data are expressed as Mean ± SE. Number of animals in each group is six.  
 - Means, which share the same superscript symbol(s), are not significantly different.



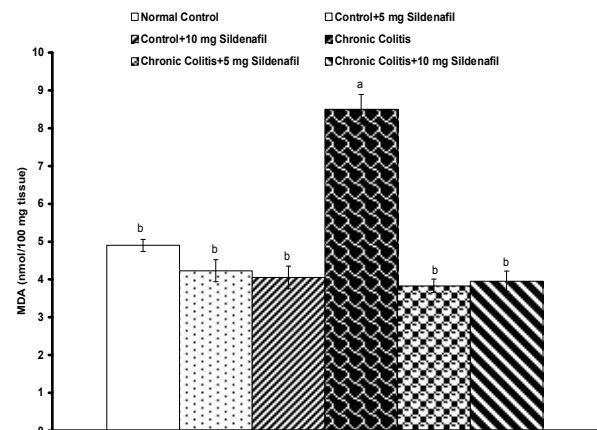
**Figure 1:** Effect of sildenafil citrate on serum TNF- $\alpha$  of normal and AA-induced colitic rats. Means, which share the same superscript symbol(s), are not significantly different. F-prob.: P<0.001; LSD at 5% level: 15.23; LSD at 1% level: 21.35.



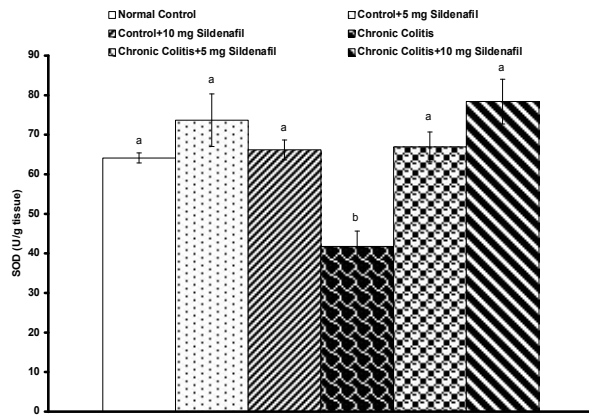
**Figure 3:** Effect of sildenafil citrate on GSH content in colon of normal and AA-induced colitic rats. Means, which share the same superscript symbol(s), are not significantly different. F-prob.: P<0.001; LSD at 5% level: 1.12; LSD at 1% level: 1.58.



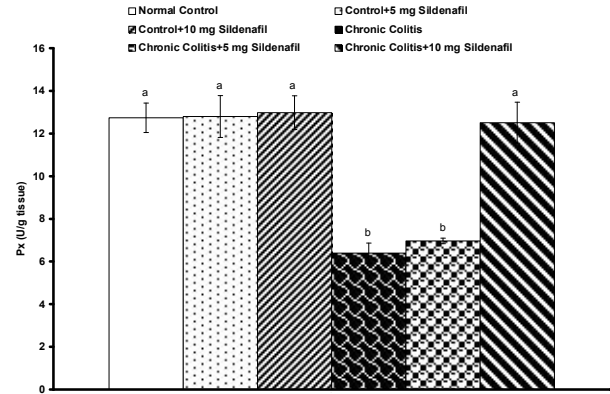
**Figure 2:** Effect of sildenafil citrate on serum IL-1 $\beta$  of normal and AA-induced colitic rats. Means, which share the same superscript symbol(s), are not significantly different. F-prob.: P<0.001; LSD at 5% level: 12.53; LSD at 1% level = 17.57.



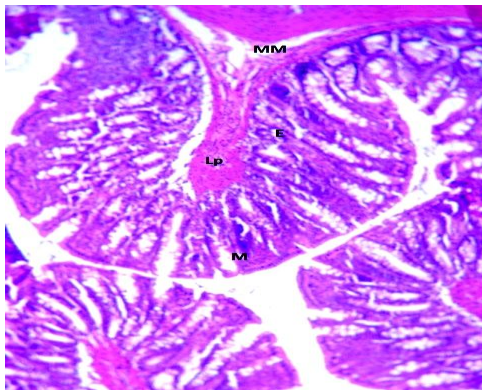
**Figure 4:** Effect of sildenafil citrate on MDA level in colon of normal and AA-induced colitic rats. Means, which share the same superscript symbol(s), are not significantly different. F-prob.: P<0.001; LSD at 5% level: 1.10; LSD at 1% level: 1.68.



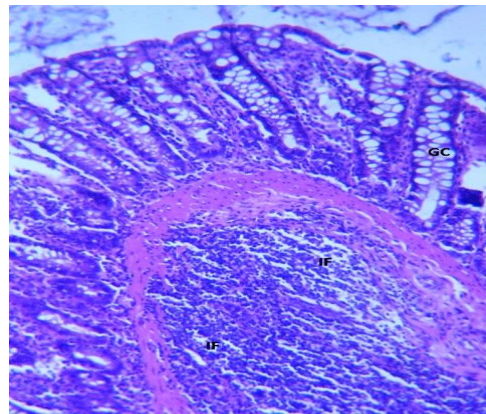
**Figure 5:** Effect of sildenafil citrate on SOD activity in colon of normal and AA-induced colitic rats. Means, which share the same superscript symbol(s), are not significantly different. F-prob.:  $P < 0.01$ ; LSD at 5% level: 18.82; LSD at 1% level: 26.38.



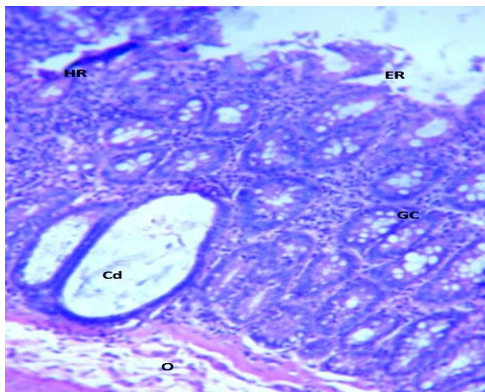
**Figure 6:** Effect of sildenafil citrate on GPx activity in colon of normal and AA-induced colitic rats. Means, which share the same superscript symbol(s), are not significantly different. F-prob.:  $P < 0.001$ ; LSD at 5% level: 3.18; LSD at 1% level: 4.46.



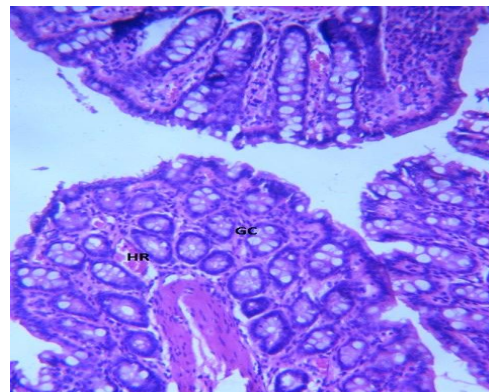
**Figure 7:** Photomicrograph of colon section of normal rats showing normal histological architecture. M: mucosa; E: mucosal epithelial cells; MM: muscularis mucosa; Lp: lamina propria.



**Fig. 9:** Photomicrograph of colon section of chronic acetic AA-colitis in rats treated with 5 mg/kg b. wt. sildenafil citrate showing potential increase in the number of goblet cells (GC) in mucosa and hemorrhage and leukocytic infiltration (IF) in the submucosa. H&E X40



**Fig. 8:** Photomicrograph of colon section of chronic AA-induced colitis in rats showing submucosal proliferated fibrous tissue, some patches of surface erosion (ER) and loss of the superficial epithelium of mucosa, cystic dilation (Cd) of mucosal glands, hemorrhage (HR) and submucosal oedema (O). H&E X40



**Fig. 10:** Photomicrograph of colon section of chronic AA-induced colitis in rats treated with 10 mg/kg b. wt. sildenafil citrate showing hemorrhage (HR) and goblet cells (GC). H&E X40

#### 4. Discussion:

The pathogenesis of IBD involves an interaction between genetic and environmental factors (Rampton and Shanhan, 2008). Although the pathophysiology of IBD is not known with certainty, immunological processes and reactive oxygen species (ROS), such as peroxide anion, hydrogen peroxide ( $H_2O_2$ ), and hypochloric acid have been proposed to contribute considerably in development of tissue injury (Grisham, 1994 and Fiocchi, 1998).

Under normal physiological conditions, chemical and antioxidant defenses protect tissues from the damaging effects of ROS. The toxic oxidants can cause tissue injury if the rate of their production exceeds the capacity of endogenous antioxidant defense mechanisms (Williams *et al.*, 1990 and Kruidener *et al.*, 2003). The gut is potentially vulnerable to oxidant injury due to a low concentration of antioxidant enzymes, which are mainly localized in epithelial cells (Grisham *et al.*, 1990). This suggests that colonic inflammation may produce high levels of oxidant products that probably exceed this relatively low antioxidant capacity and lead to oxidative stress and epithelial cell disruption (Lih Brody *et al.*, 1996 and Yunus *et al.*, 1999).

Oxidative stress and its consequent lipid peroxidation are able to aggravate free radical chain reactions, disrupt the integrity of intestinal mucosa barrier and activate inflammatory mediators, resulting in increased colonic MDA contents, as shown in both human and experimental animal studies (Girgin *et al.*, 2000 and Ek *et al.*, 2007). The present results showed that the levels of colonic MDA in colitis group were higher than the normal control group. Rats treated with both 5 and 10 mg/kg sildenafil have significantly reduced levels of MDA compared to the rats with AA-induced colitis. Therapy with sildenafil resulted in a marked decrease in MDA levels in colon, suggesting that sildenafil successfully inhibited lipid peroxidation induced by acetic acid. These results are in accordance with the findings of Iseri *et al.* (2009) who found that a subcutaneous dose of 5 mg/kg sildenafil ameliorated the elevated colonic MDA levels.

Furthermore, the status of antioxidant enzymes e.g., superoxide dismutase (SOD) decides the systemic protection against inflammation. SOD restrains the lipid peroxidation in colon by eliminating free-radicals, converting superoxide into peroxide ( $H_2O_2$ ). A significant body of research has indicated that decreasing SOD activity in the local colon tissue leads to mucosal injury because of reduced ability of oxidative radicals scavenging (Barazzone & White, 2000 and Kriegstein *et al.*, 2001). Our study showed that SOD activity significantly decreased in the colitis control group and these data were in agreement with several observations demonstrating the decrease in SOD activity under the effect of different sorts of stress

(Deliconstantinos and Villiotou, 2000). In contrast to the present study, Kruidener *et al.* (2003) demonstrated that colonic mucosa Cu/Zn-SOD and Mn-SOD levels were higher than the control levels in patients with inflammatory bowel disease. Also, Kuralay *et al.* (2003) showed that tissue SOD levels were elevated in response to oxidative stress in AA-induced colitis model. Our data demonstrated that administration of sildenafil ameliorated alterations induced by AA in SOD, to reach the normal range of control group.

GSH is an important nonenzymatic antioxidant and, similar to other sulfhydryl-containing products, it also has regulatory and protective roles in the body. Our findings indicate a slightly lower GSH activity in the colitis group than control. Moreover GSH activity in sildenafil treated groups was significantly increased than control and colitis groups. These results are in agreement with those of Iseri *et al.* (2009) and Erarslan *et al.* (2010) who reported diminished colonic GSH levels in acetic acid-induced colitis in rats. In addition, Nieto *et al.* (2000) found that the level of GSH was lower in TNBS induced ulcerative colitis. Furthermore, Ek *et al.* (2007) found a significant decrease in the activity of GSH in the colonic tissue of the acetic acid induced-colitis.

Regarding glutathione peroxidase, the current data revealed a significant depletion of colon GPx activity and treatment of AA-induced colitis groups with sildenafil potentially alleviated the GPx activity. Because GPx is responsible for most of  $H_2O_2$  neutralization (Pastor *et al.*, 1997), which upon diffusion to the extracellular space result in oxidative disruption of apical intercellular tight junctions and colonic epithelial basement membranes (Pravda, 2005), sildenafil might be contributing to the integrity of the gastrointestinal barrier function.

Another important finding of the present study was that sildenafil, in dose dependent manner, attenuated production of the pro-inflammatory cytokines, TNF- $\alpha$  and IL-1 $\beta$ , which are believed to play a significant role in the pathogenesis of IBD (El-Medany *et al.*, 2005; Mahgoub *et al.*, 2005). They possess overlapping and synergetic activities inducing the production of other cytokines, adhesion molecules, arachidonic acid metabolites, as well as activating immune and non-immune cells. An *in vitro* study demonstrated that sildenafil was unable to decrease hypoxia-induced upregulation of TNF- $\alpha$  and IL-1 $\beta$  mRNA in pulmonary artery (Tsai *et al.*, 2006). Similarly, sildenafil did not significantly inhibit any markers of inflammation including TNF- $\alpha$ , IL-4 and IL-5 levels in a murine model of allergic asthma (Clayton *et al.*, 2004). In accordance with our findings, another study demonstrated that pretreatment with PDE5 inhibitor zaprinast at a dose of 10 mg/kg blocked lipopolysaccharide (LPS)-induced increase of TNF- $\alpha$

level in serum of mouse (Iric *et al.*, 2001). However, the origin of these cytokines detected in serum in our study needs to be clarified.

AST and ALT estimation in serum is a useful quantitative marker to indicate hepatocellular damage (Hwang & Wang, 2001; Singh *et al.*, 2001). The increased activities of these serum markers observed in our study correspond to considerable liver damage induced in AA-induced colitis in rats. Administration of sildenafil significantly decreased the levels of AST and ALT, suggesting that it offers protection by preserving the structural integrity of the hepatocellular membrane. On the other hand, there was a significant elevation in creatinine and urea in the serum of the chronic induced colitis groups. Sildenafil administration significantly ameliorated the deteriorated renal function and this suggests that sildenafil may have a renal protective effect in AA-induced colitis.

Histopathological investigation of colon section taken from AA-treated rats showed superficial erosion of mucosal epithelial cells, diffuse goblet cells formation in mucosal epithelium with oedema and diffuse inflammatory cells infiltration in lamina propria and hypertrophy in the muscularis. These data are in accordance with Iseri *et al.* (2009) who revealed that AA induced massive epithelial loss, destruction of Lieberkuhn crypts, severe inflammatory cell infiltration, vasculitis and submucosal edema. On the other hand, treatment with both doses of sildenafil produced amelioration of histopathological changes induced by acetic acid confirming protection by such agent.

In conclusion, sildenafil citrate is beneficial in AA-induced colitis in rats and the mechanism of its anti-inflammatory action may involve the maintenance of oxidant-antioxidant status, prevention of lipid peroxidation and cytokine release.

#### Corresponding author:

Osama M. Ahmed  
Physiology Division, Zoology Department, Faculty of Science, Beni-Suef University.  
Salah Salim St., P.O. 62511, Beni-Suef, Egypt.  
E-mail: osamamoha@yahoo.com  
Mobile: +2-0100+1084893

#### References:

**Barazzone, C. and White, C. W. (2000):** Mechanisms of cell injury and death in hyperoxia. Role of cytokines and Bcl-2 family proteins. *Am J Respir Cell Mol Biol.*, 22:517e9.

**Beutler, E.; Duron, O. and Kelly, B. M. (1963):** Improved method for the determination of blood glutathione. *J. Lab. Clin. Med.*, 61 (5): 882-888.

**Canadian Council on Animal Care.** Guide to the care and use of experimental animals. Vol. 2, CCAC, Ottawa, Ontario, Canada, 1993.

**Carter, M. J.; Lobo, A. J. and Travis, S. P. (2004):** Guidelines for the management of inflammatory bowel disease in adults. *Gut*, 53(S V):v1-v16.

**Clayton, R. A.; Dick, CAJ. and Mackenzie, A. (2004):** The effect of selective phosphodiesterase inhibitors, alone and in combination, on a murine model of allergic asthma. *Respir. Res.*, 5: 14.

**Colon, A.L.; Menchen, L.A.; Hurtado, O.; De Cristobal, J.; Lizasoain, I.; Leza JC, et al. (2001):** Implication of TNF-alpha convertase (TACE/ADAM) in inducible nitric oxide synthase expression and inflammation in an experimental model of colitis. *Cytokine*, 16: 220-6.

**Deliconstantinos, G. and Villiotou, V. (2000):** Gas phase oxidants of cigarette smoke increase nitric oxide synthase and xanthine oxidase activities of rabbit brain synaptosomes. *Neurochem. Res.*, 25: 769-774.

**Ek, R. O.; Serter, M.; Ergin, K.; Yildiz, Y.; Cecen, S. and Kavak, T. (2007):** The Effects of caffeic acid phenethyl ester (CAPE) on TNBS-induced colitis in ovariectomized rats. *Dig Dis Sci.*, 1007:1609-17.

**El-Medany, A.; Mahgoub, A.; Mustafa, A.; Arafa, M. and Morsi, M. (2005):** The effects of selective cyclooxygenase-2 inhibitors, celcoxib and rofecoxib, on experimental colitis induced by acetic acid in rats. *Eur. J. Pharmacol.* 507, 291-295.

**Erarslan, E.; Turkay, C.; UZ, B.; Kaya, A.; Koca, C.; Bayrak, R. and Alici, Ö. (2010):** The Effects of Caffeic Acid Phenethyl Ester (CAPE) on Acetic Acid Induced Colitis in Rats . *The New Journal of Medicine*, 27: 106-112.

**Fiocchi, C. (1998):** Inflammatory bowel disease: etiology and pathogenesis. *Gastroenterology*, 115: 182-205.

**GIBSON, A. (2001):** Phosphodiesterase 5 inhibitors and nitregic transmission- from Zaprinast to Sildenafil. *Eur. J. Pharmacol.*, 411, 1-10.

**Girgin, F.; Karaoglu, O.; Erkus, M.; Tuzun, S.; Ozutemiz, O. and Dincer, C. (2000):** Effects of trimetazidine on oxidant/ antioxidant status in trinitrobenzenesulfonic acid-induced chronic colitis. *J Toxicol Environ Health A*, 59: 641-52.

**Grisham, M. B. (1994):** Oxidant and free radicals in inflammatory bowel disease. *Lancet*, 344: 859-61.

**Grisham, M.B.; Gaginella, T.S.; von Ritter, C.; Tamai, H.; Be, R.M. and Granger, D.N. (1990):** Effects of neutrophil-derived oxidants on intestinal permeability, electrolyte transport, and epithelial cell viability. *Inflammation*, 14: 531-42.

**Hwang, D. F. and Wang, L. C. (2001):** Effect of taurine on toxicity of cadmium in rats. *Toxicology*, 167:173-80.

- Iric, K.; Fujii, E. and Ishida, H. (2001):** Inhibitory effects of cyclic AMP elevating agents on lipopolysaccharide (LPS)-induced microvascular permeability change in mouse skin. *Br. J. Pharmacol.*, 133: 237–42.
- Iseri, S. O.; Ersoy, Y.; Ercan, F.; Yuksel, M.; Atukeren, P.; Gumustas, K. and Alican, I. (2009):** The effect of sildenafil, a phosphodiesterase-5 inhibitor, on acetic acid-induced colonic inflammation in the rat. *Journal of Gastroenterology and Hepatology* 24: 1142–1148.
- Kaplan, A. (1984):** Urea. Kaplan A et al. *Clin Chem The C.V. Mosby Co. St Louis. Toronto. Princeton;* 1257-1260 and 437 and 418.
- Kar, M. and Mishra, D. (1976):** Catalase, Peroxidase and Polyphenoloxidase activities during rice leaf senescence. *Plant Physiol.*, 57: 315-319.
- Kirsner, J.B. (1995):** Chronic inflammatory bowel disease: overview of etiology and pathogenesis. In: Berk JE, ed. *Bockus Gastroenterology*. Philadelphia, PA: Saunders, 1293–325.
- Krieglstein, C. F.; Cerwinka, W. H.; Laroux, F. S.; Salter, J. W.; Russell, J. M. and Schuermann, G. (2001):** Regulation of murine intestinal inflammation by reactive metabolites of oxygen and nitrogen: divergent roles of superoxide and nitric oxide. *J Exp Med.*, 194:1207e18.
- Kruidener, L.; Kuiper, I.; Lamers, C. B. and Verspaget, I. (2003):** Intestinal oxidative damage in inflammatory bowel disease: semi quantification, localization and association with mucosal antioxidants. *J. Pathol.* 201, 28–36.
- Kuralay, F.; Yildiz, C.; Ozutemiz, O.; Islekel, H.; Caliskan, S. and Bingol, B. (2003):** Effects of trimetazidine on acetic acid-induced colitis in female Swiss rats. *J Toxicol Environ Health*, 66: 169–9.
- Lih-Brody, L.; Powell, S. R. and Collier, K. P. et al. (1996):** Increased oxidative stress and decreased antioxidant defenses in mucosa of inflammatory bowel disease. *Dig Dis Sci.*, 41:2078- 2086.
- MacPherson, B. and Pfeiffer, C. (1978):** Experimental production of diffuse colitis in rats. *Digestion*, 17: 135–50.
- Mahgoub, A.; El-Medany, A.; Mustafa, A.; Arafah, M. and Moursi, M. (2005):** Azithromycin and erythromycin ameliorate the extent of colonic damage induced by acetic acid in rats. *Toxicol. Appl. Pharmacol.* 205, 43–52.
- Marklund, S. L. and Marklund, G. (1974):** *Eur. J. Biochem.*, 47, 469.
- Murray, R. (1984):** Aspartate aminotransferase. Kaplan A et al. *Clin Chem, The C.V. Mosby Co. St Louis. Toronto. Princeton*, 1112-116.
- Nieto, N.; Torres, M. I.; Fernandez, M. I.; Giron, M. D.; Rios, A. and Suarez, M. D. (2000):** Experimental ulcerative colitis impairs antioxidant defense system in rat intestine. *Dig Dis Sci.*, 45: 1820–7. 35.
- Pastor, A.; Collado, P. S.; Almar, M. and Gonz'alez-Gallego, J. (1997):** Antioxidant enzyme status in biliary-obstructed rats: effects of N-acetylcysteine. *J. Hepatol.*, 27, 363–367.
- PC-STAT (1985):** One way analysis of variance. Version IA (C). Program coded by Roa, M.; Blane, K. and Zonneberg, M. University of Georgia, USA.
- Pravda, J. (2005):** Radical induction theory of ulcerative colitis. *World J. Gastroenterol.* 11, 2371–2384.
- Preuss, H.G.; Jarrell, S.T.; Scheckenbach, R.; Lieberman, S. and Anderson, R. A. (1998):** Comparative effect of chromium vanadium and Gymnema sylvestre on sugar-induced blood pressure elevation in SHR. *J. Am. Coll. nutr.*, 17 (2): 116-123.
- Rampton, D. S. and Shanahan, F. (2008):** Increased health burden associated with *Clostridium difficile* diarrhoea in inflammatory bowel disease. *Aliment Pharmacol Ther.*, 34(3):394-5.
- Rosalmeida, M.C., Saraiva, L.D., Da Grac,A, J.R., Barreto, B.I., Da No'brega, M.V., Gondim, F.A., Rola, F.H. and Santos, A.A. (2003):** Sildenafil, a phosphodiesterase-5 inhibitor, delays gastric emptying and gastrointestinal transit of liquid in awake rats. *Dig. Dis. Sci.*, 48, 2064–2068.
- Santos, C. L.; Souza, MHL P and Gomes, A. S. (2005):** Sildenafil prevents indomethacin-induced gastropathy in rats: role of leukocyte adherence and gastric blood flow. *Br. J. Pharmacol.*, 146: 481–6.
- Singh, S.N.; Vats, P.; Suri, S.; Shyam, R.; Kumria, M.M.L. and Ranganathan, S. (2001):** Effect of an antidiabetic extract of *Catharanthus roseus* on enzymic activities in streptozotocin induced diabetic rats. *J Ethnopharmacol.*, 76: 269–77.
- Tsai, B. M.; Turrentine, M. W. and Sheridan, B. C. (2006):** Differential effects of phosphodiesterase-5 inhibitors on hypoxic pulmonary vasoconstriction and pulmonary artery cytokine expression. *Ann. Torac. Surg.*, 81: 272–8.
- Williams, J. G.; Hughes, L. E. and Hallett, M. B. (1990):** Toxic oxygen metabolite production by circulating phagocytic cells in inflammatory bowel disease. *Gut* 31, 187–193.
- Young, D.S. (1995):** Effects of drugs on Clinical Lab. Tests, 4th ed AACCPress.
- Yunus, Y.; Yuksel, M. and Berrak, C. (1999):** The effect of antioxidant therapy on colonic inflammation in the rat. *Res. Exp. Med.* 199, 101–110.



## Problems of housing environment for the elderly

Sakeena Mohamed Abdel-Rahman Basabrain

Internal design Dept., Faculty of Arts and Designs, King Abdul- Aziz University, Jeddah 21412, Kingdom of Saudi Arabia

[Dr.sakeena@live.com](mailto:Dr.sakeena@live.com)

**Abstract:** The aging is a growing concern in Saudi Arabia, as is the case in other countries, where Saudi culture is based on the close relationship between the elderly and their families. So, there is an urgent need to understand the cultural viewpoints of the people of Saudi Arabia's elderly to assess the extent of adaptation of the elderly with housing environment in the family, to stay at home independently as national policies should for housing, municipal and household application of the conditions that must be taken into account when discussing the housing needs of people with disabilities, elderly people and a commitment to the principles of the design world to the seventh Assistant elderly to continue to live in their own homes as long as possible and provide a better living environment for them. Furthermore, is to facilitate their movement and ensure their integration in society and consolidate this culture in society.

[Sakeena Mohamed Abdel-Rahman Basabrain. **Problems of housing environment for the elderly**. Life Science Journal 2012;9(1):362-366]. (ISSN: 1097-8135). <http://www.lifesciencesite.com>. 52

**Keyword:** Problems; housing environment; elderly.

The aging world population increases steadily and at an amazing rate. It is estimated that the ages of 23 million people in 2040 will be between the ages of 75 to 84 years old, so, 12 million will reach the age of 85 years and over, and most of them adults who suffer from aging and physiological changes show a desire to stay in their homes and would shrink the number of older people who have daily activities by 123% between 1990 to 2030 for the total world population. As well as 70% of the elderly as those living in the community find it difficult to bathe, use the phone, cooking, and washing. (Sonia et al., 1997)

Thus, the aging of the population is a growing concern in Saudi Arabia, as is the case in other countries, where Saudi culture is based on the close relationship between the elderly and their families. Most older people prefer to live in their homes, where they lived when they were younger more than the specialized institutions. So, there is an urgent need to create the environment to the needs and activities of the elderly in daily life, on the basis of international designs that provide a higher level of ease of use, ease of access and the ability to adapt to all users regardless of their age, or their potential. (Afacan and Futures, 2008). Then, It is imperative to conduct studies to understand the cultural viewpoints of the people of Saudi Arabia's elderly to assess the extent of adaptation of the elderly with housing environment with their family, to stay at home independently. Where, independency is intended not to adopt and support for non-elderly, while, environmental adaptation Means the need to intervene to help the elderly to stay at home

independently and ease the burden of care on their families (Laura, 2009).

The Paragraph 1 of Article 10 and the recommendations no. 25 and 29 of the international recommendations Action Plan on Ageing, as States parties should make every effort to support, protect and strengthen the family and to help them, according to a system of cultural values in every society, to meet the needs of their elderly dependents.

The recommendation 29 encourages Governments and non-governmental organizations to establish social services to support the whole family when elderly people at home, and to implement measures especially for low income families wishing to care for the elderly at home. It should also provide such assistance to people living alone or elderly couples who want to stay in the house.

Also, the recommendations 19 to 24 confirms that, the elderly housing should be viewed as more than just a shelter, as it, in addition to the significance of physical, psychological and social significance which should be taken into account. Thus, national policies should help elderly persons to continue living in their homes as long as possible, through the reform of housing and development, improvement and adaptation to the ability of those persons to access and use (Recommendation 19). Recommendation 20 emphasizes on that plan and the laws of the reconstruction and development of urban paying special attention to the problems of the elderly and to provide assistance to them to ensure their social integration. While, recommendation 22 draws attention to the need to take into account the functional capacity of the elderly in order to provide a better living environment for them, and to facilitate

their movement and communication through the provision of adequate means of transport. (Committee on Economic, social and Cultural Rights, 1995).

Conditions that must be taken into account when discussing the housing needs of people with disabilities and the elderly.

#### Universal Design:

The design of products and environments to be usable by all people, to the extent Possible, without. Need for adaptation or specialized design (Skulski, October 2007).

#### Can be accessed:

Generally refers to houses or other dwellings that meet the requirements specified with special needs to access. These requirements Found on in international and local standards building codes, model, and regulations of the amendments to the Housing Act of 1988, the Institute of American National Standards institute (ANSI), Standards A117.1 - 1998 with the guiding principles of the U.S. Disability Act. These rules, guidelines and laws show the standard dimensions such as the width of the door, and space for wheelchair movement, and elevations for cabinets, sinks and kitchens, and high electrical outlets, etc. (NATTAP, 1998).

#### Adaptable:

The design allows to change some features of the housing design's to meet the needs of the individual with a disability or a person who is facing travel restrictions by age. These elements of the basic design can be modified such as doors and entrances, wide halls with free of obstacles as part of the basic



Fig.1 People who require an accessible entrance should not be exiled to a remote delivery area such as the one shown here.

([Rudolph et al., 2001](#))

design. The adaptable intended concept is adaptation that allows the design (amendment or addition) easily and without the use of skilled labor, and without changing the basic structure of the building, for example, may support the design of the walls of the bathroom bars additional to the future, (fig., 6).

Cupboards can be designed under the basin to be removable where it is replaced storage space under the sink to the area of the knee for the wheelchair user.

#### Visible

Intended to be a housing suitable for the reception of people with special needs, and/or the elderly, even the owners of housing are not from these categories, and meet their needs in the future when they get older, for example, the doors wide enough for a wheelchair, and corridors can be accessed easily. This features make the dwelling for residential not change due to disability and lack of movement of its occupants.

The seven principles of universal design: (Demirkan, 2007; Rudolph et al., 2001; Skulski, October 2007)

1. Design capability for use of persons with different abilities (fair use)  
Equitable use the design is useful and marketable to people with diverse abilities  
Should design the building so that it is subject to the use of all persons without exception, and not to isolate or grants privileges to a group without the other and provide privacy, security, safety and comfort for all, for example, be a means to enter the building and one for all. Figs. (1 and 2)



Fig.2 People who require an accessible entrance should not be exiled to a remote delivery area such as the one shown here.

**2. Flexibility in use:**

The design accommodates a wide range of individual preferences and abilities, providing the

option in the methods of use, and provides the ability to adapt quickly to the user. fig. (3)



Fig. 3. Available space for the movement of the chair is not flexible enough for the passage of the chair easily by threshold and increase the difficulty of Use

**3. Simple and intuitive use:**

It is easy to understand, regardless of the user experience, knowledge, language skills, or current concentration level. Fig. (4)



Fig. 4. The absence of detectable information makes these elevator call buttons difficult for first time users with reduced vision to recognize. (Rudolph et al., 2001 )

**4. Concrete information:**

Perceptible information The design communicates necessary information effectively to the user,

regardless of ambient conditions or the user's sensory abilities. Actually reach the necessary information to the user, regardless of the circumstances surrounding or sensory abilities. fig. (5)



Fig. 5 In these images, you can see the band which helps the blind people to find their directions. However, the band above is blocked by a buffet <http://studyofintroductiontoarchitecture.blogspot.com>

**5. Tolerance for Error:**

The design leads to reduce errors and risk intentional or unintentional. It also gives notice hazards and the adverse consequences of accidental

or unintended actions of the warnings and errors, and to provide security an Tolerance for error the design minimizes d safety. fig. (6)



Fig. (6) processing bath chair Palmkabd mobile, The design leads to reduce errors and risk  
[http://ezaccessbathrooms.com/Senior\\_Friendly\\_Bathroom\\_Houston.aspx](http://ezaccessbathrooms.com/Senior_Friendly_Bathroom_Houston.aspx)

**Low physical effort:**

The design can be used efficiently comfortable\_and with a minimum of fatigue fig.(7)



Fig. 7 Climbing these stairs needs much physical effort, and it makes people tired .This kind of design is completely contradictory to universal design.

**7. Providing appropriate size and space for movement**

Regardless the size and length of the users, fig.(8).



Fig.(8) Size and space for approach and use Appropriate size and space is provided for approach, reach, manipulation and use, regardless of the user's body size, posture, or mobility

**Conclusion:**

From this point to be taken into account the conditions that must be taken into account when discussing the housing needs of people with disabilities and the elderly, and design principles of the seventh global planning and organization of

studies on the creation of the housing environment for the elderly, both within their homes or in public areas and has appeared now in Saudi Arabia Assembly government under the Ministry of Social Affairs and developed from within the objectives of the establishment and restoration of facilities needed

by the elderly in their homes and the role of worship as "charity care rights.". There is a strong need emphasizes the need for more research, studies, and increased attention to issues of different affecting this area, both in the field of housing policy and/or the environment, social studies, educating families and the community of the importance of these studies and to their scarcity and in spite of its importance.

#### References:

1. Afacan Y and Futures DI. (2008). Designing for an Ageing Population: Residential Preferences of the Turkish Older People to Age in Place.
2. Committee on Economic, social and Cultural Rights, (1995) general recommendation no., 6 the economical, social and cultural rights for the elder
3. Demirkan H. (2007) Housing for the aging population. Eur Rev Aging Phys Act.
4. [http://ezaccessbathrooms.com/Senior\\_Friendly\\_Bathroom\\_Houston.aspx](http://ezaccessbathrooms.com/Senior_Friendly_Bathroom_Houston.aspx). SENIOR-FRIENDLY BATHROOM DESIGNS [http://www.adcet.edu.au/Cats/Technology\\_and\\_Facilities/Physical\\_Access.chpx](http://www.adcet.edu.au/Cats/Technology_and_Facilities/Physical_Access.chpx)
5. Haziran .( 2011) Çarşamba UNIVERSAL DESIGN PRINCIPLES Available at: <http://studyofintroductiontoarchitecture.blogspot.com/> to be useful for people having sensorial disabilities
6. Laura N. (2009) Adaptations for Older Adults and Their Families in the Home and Community: international handbook of occupational therapy intervention.
7. NATTAP. (1998). Making homes accessible assistive technology and home modification. Available at: <http://www.resnaprojects.org/nattap>
8. Rudolph WG, Mayor, Rudy W, Catherine P, et al. (2001) universal desyg new yonrk. In: Disabilities MsOfPw and York TCoN (eds). New York: A City of New York Office of the Mayor Publication.
9. Skulski J. (2007) Designing for inclusive play: Applying the principles of universal design to the playground. Bloomington,. Indiana University-Bloomington: National Center on Accessibility.
10. Sonia L, E S and Combs R. (1997) Characteristics Related to Elderly Persons' Perceived Difficulty of Remaining in Their Current Homes Family and Camume, Sciences ResearchJournal 1. 26,

## Factors Affecting Public Sector Investment in Agriculture in Iran: The Usage of Unrestricted Error Correction Model

Seyed Nemat Allah Mousavi, Azadeh Dogani and Javad Torkamani

Department Of Agricultural Economics, Marvdasht Branch, Islamic Azad University, Marvdasht, Iran

\*Corresponding author: [mousavi\\_sn@yahoo.com](mailto:mousavi_sn@yahoo.com)

**Abstract:** Agriculture in Iran is the greatest economical sector after petroleum and services sectors which has devoted about 20 percent of national gross production and main share of non-petroleum exports, so that, this section development has determinate role in economical growth. Investment in agriculture section is one of factors which due to increase in demand for food and other agriculture products can cause to develop production and more employment in agriculture section. Therefore, in this section, it has been tried that Long-term effect of parameters such as petroleum incomes, investment stock, value-added, national income and inflation rate on state or governmental investment by use of conditional ARDL pattern is in frame of Pesaran and Shin (It applies for time series and variables can be I (0) or I (1)), this is studied for 1356-1386 periods. The results of this study showed that there is Long-term relation between governmental investment, petroleum incomes, investment stock, value-added, national income and inflation rate. On the other hand, governmental investment has the most and least sensitive to Value-added and petroleum income, respectively.

[Seyed Nemat Allah Mousavi, Azadeh Dogani and Javad Torkamani. **Factors Affecting Public Sector Investment in Agriculture in Iran: The Usage of Unrestricted Error Correction Mode** Life Science Journal 2012;9(1):367-373]. (ISSN: 1097-8135). <http://www.lifesciencesite.com>. 53

**Key words:** Governmental investment, ARDL model, error correction model, elasticity.

### INTRODUCTION

Agriculture section is one of the most important sections in Iran economy. It is done about one-quarter of gross domestic production and foreign exchange incomes resulting from non-petroleum goods exports and country employment and to meet needs about 80 percent of society food needs via this section on one hand, it is created evolution in this section about high population growth, continuous increase in food demand and increasingly need in various economical section to agriculture products, so that it can increase in quantity and variety of different products in short time (Hazhbar kiani & Jhonvislo 1379). In addition, 43% of country population live in village, so the living of many of them is related to this section. Hence, agriculture section is considered as development axis (Kiani rad & Koopahi 1379). Generally, among investment in agriculture section has important role and specific place. The investment in agriculture section, due to increase in demand for food and other agriculture products, can cause to develop production and employment. In fact, increase in demand cause to enhance prices levels and increasing price levels cause to enhance motive for investing. Therefore, more investment is accompanied by production growth and more employment. Besides, prior and post relation of agriculture with other parts helps to develop production and employment in them. Most of agriculture activities are done in rural regions, thus investment development in agriculture section in

frame of public and private investment can cause to create more occupational opportunity in rural regions, as a result it causes to prevent rural-people immigration to cities and increase in growth rate at agriculture section (Amini & Falihi 1377). On one hand, the study of changes trend in production and imports at agriculture section clear this fact which by existing increase in main agriculture products manufacture, it is also provided main share of agriculture products by imports. It is necessary to pay attention to agriculture section via the study of agriculture section share from total value-added and human resource employment and its comparison with investment share in this section of whole investment country. In respect to importance of agriculture section in economical growth and development and investment power to enhance agriculture products manufacture and to develop this section, the investment has typical importance in it (Hazhbar kiani & Jhonvislo 1379). In Iran, the subject of invest and investment is accompanied by tremendous problems because of server dependence to petroleum incomes and its price unstable and to be high risk, in this reason investment in various sections such as agriculture one has had server fluctuation. In agriculture section, the problems related to investment have been more obvious due to existing structural bottlenecks and lack of financial equipments of most beneficiaries. In respect to this point that agriculture section has important role in domestic gross production and employment and it

provides necessary population needs, but unfortunately, investment growth was not optimum in last decades and its share has been 5.9 percent from investment in national economic during two last decades. Although, it has been low the ratio of investment to domestic gross production in mentioned period and on the average it was about 16.5 percent, but this ratio has been 3.9 percent on average in agriculture section. In another words, it is returned only 3.9 percent of value-added sum in agriculture section as investing to it. While this ratio has been estimated about 24.6 and 15.4 percent for services and industry section, respectively in respect to investment importance in agriculture section and its effect on macro-economic variables, it is important to identify effective factors on it (Hojati 1380). One of important production elements in investment economy is fund and it is consisted of some aspect that it is obtained income from it, and it is stated based on money. It usually applied fund or capital term by term of capital goods, commonly. Sometimes it is known fund as capital money or property capital.

The concept of investment economy with its business concept which is applied in daily conversation has many differences. Economical investment in whole economy just includes expenses which increase capital goods stock such as factories, technical equipments and or consumption goods stock. The title of investment is called for expenses which are applied to create factories and completely new equipment or increase in existing factories capacity or increase in goods stock.

#### ***The study of public investment procedure in agriculture section and its transgression challenges.***

Table 1 shows investment rate of governmental section in agriculture section, each section share and growth rate from 1376 to 1386 by fixed prices in 1376.

The challenges in the agricultural sector investments include:

- 1- To be low rate of capital revenue in agriculture section which it is resulted in decrease in investment trend in this section in respect to keep low agriculture products prices.
- 2- Lack of foreign exchange and rial credits to form capital in this section.
- 3- Not to be provided financial, economical and technical equipments to attract foreign investment.
- 4- Lack of investment and essential financial resources to create and extend conversional industries and technical units.
- 5- Not to be recognized reforming instruments and conducting government to conduct private section resources and bank regime in direction of production investment and lack of it's continuous.

6- Lack of encouragement regime for private section partnership and to commerce production in agriculture section.

7- Lack of supportive elements such as investment insurance in agriculture section.

***Table 1: Investment in the agricultural sector during the period 1386-1356 (billions of rial)***

The share of public investment	Growth rate of public investment	public investment in agriculture section by fixed prices in 1376	The total investment	year
82.2	-3.6	2718.7	3306	1376
76.9	-16.9	2257.1	2933	1377
70.2	56.6	3536.6	5034	1378
124.3	54.4	5462.5	4393	1379
66.1	-39.5	3301.3	4991	1380
145.5	163.1	8688.7	5968	1381
195.02	45.7	12666.9	6495	1382
149.03	-6.5	11831.6	7939	1383
200.2	57.5	18645.5	9309	1384
169.1	-21.8	14568.0	8613	1385
201.09	21.2	17666.0	8785	1386

Source: Management and Planning Organization, a time series of economic statistics - and the central bank's balance sheet

#### **Review on studies:**

Bagheri & Torkamani (1379) have studied situation and relation between private and public investment in agriculture section using coaggregation test. The results of estimation for this study private investment showed that state investment, bank credits, prices index and state investment with one pause over private investment is effective and also there is one long-term balance relation between function variables by use of coaggregation test and the important result of this study is the positive effect of state investment on private investment.

Salimi far & Ghavi (1381) showed that there is significant relation between effect of granted credits of bank net on private section investment by estimate private section investment pattern as function of public section investment, domestic gross production, loans and grant credits of bank net.

Khaledi et al (1387) studied the effective elements on rural poverty and agriculture economy growth with emphasis to agriculture section investment by use of statistic in period of 1350-1382 and via seemingly unrelated equations (SURE). The result of this study showed that although investment in agriculture section has been accompanied by economical growth in this part; but, it has not been superficial the rate and distribution of revenue resulting from this growth. It is seemed that agriculture economical growth revenue is not

directed towards the rural poor people. Hence, in addition to control inflation rate and to improve revenue distribution resulting from economical growth of agriculture section, it must be noticed capital injection to agriculture section in order to support the poor people as typical in policies of investment development in this section.

Yousefi & Aziz nejad (1388) have studied the effect of domestic gross production variables, state investment, inflation rate and role of organizations such as security, ownership rights, rules and regulations, official invalidity and social security on Iran private investment during 1363-1383 years. The results showed that while domestic gross production and substructures have had positive effect on private investment, but the most important inhibition of private investment in Iran has been related to law and rights problems, lack of investment security, ownership rights and invalidity.

Ghali (2000) has studied the relation among private and public investment by method of error correction and they have concluded that in long-term, public investment has negative effect on private investment and economical growth, but in short-term it has negative or no effect on private investment and growth respectively.

Emran et al (2003) have studied the effect of economical freedom on private investment in India via estimation of investment function as method of self-regression (ARDL). The results showed that there is positive and significant relation between freedom and private investment.

Petrick (2004) has analyzed state credits about farmers investment behaviour including credit ration in Netherlands, this analysis was done by help of information economic evaluation analysis resulting from farmers families, in statistical analysis, it was determined that borrower reputation is not only prepare rent land but also the effect of ration which has credit. The estimation of one investment equation showed that access to subsidization has important role in determine farmers' investment behaviour statistically; in various features, the relation of credits ration about margin credit effect on investment was less than one. This demonstrates that credit is sometimes used as something except production investment. Besides, investment volume has reverse relation with agriculture land size. Governmental policies, which are used to promote production investment and efficiency, must emphasize to grant loan as high amounts without discrimination about small lands.

Mizutani & Tanaka (2005) have studied the effect of public substructure on private section production and effect of economical policies on investment in public substructures. Their used

information in this research is panel data related to 46 departmental domains in Japan in 1975, 80, 85, 90 & 95 years. They have applied coincident equations system consisted of private section production function, function to form public capital, governmental public investment function and regional public investment function. In this research, public capital is defined as sum of capital stock in transportation, seaport and airport, agriculture and national security sections. The results of these research shows that public capitals have effect on production efficiency in private section, and there is one complementary relation between regional or local and national governments investments. Political elements are not so effective on governmental investments in public section and national government supports to create public substructure result in local governments' investment.

### Research Method

In order to study existence of long-time relation and to obtain this relation for governmental investing in Iran agriculture section during 1356-1386 periods, it has been used the usage of unrestricted error correction model (ARDL) given by Pesaran and Sheen (1995).

They (1999) showed that ARDL pattern give consistence estimations from long-time coefficient which are normal as the asymptotic and regressors can be  $I(0)$  or  $I(1)$ . Also Inder (1993) showed that these patterns are useful for small samples (limited) and alternatively it is suggested that unrestricted error correction model (UECM) enters dynamic to estimate of short and long time coefficients. Pesaran (1997) and Inder (1993) separately showed that to enter dynamic may correct regressors in ARDL and UECM. At last, it is prevented to create false regressions and unreliable estimations (Ghorbani et al 1386).

As mentioned, the main advantage of Pesaran & Shin method is that pattern variables can be  $I(0)$  or  $I(1)$ ; it means that there is no longer need to be  $I(1)$  for all pattern variables. Besides, this pattern isn't suitable for small samples. So that Pesaran & Sheen (1995) divide ARDL approach in two stages.

In the first stage of convergence existence, we use F-test in order to study to be significant variables and then we use Pesaran & Sheen table (1996). We compare that statistic with two critical values. Its reason is that we must apply unit root test, because according to Evatera (2004), if pattern variables aren't  $I(2)$ , then F- statistic related to Pesaran & Sheen test doesn't have credit because this test is done under this theory which these are variables of  $I(0)$  or  $I(1)$ . Hence, it must be done unit root test about Pesaran & Sheen ARDL so that it is be sure



that none of pattern variable are if this statistic is larger than high critical value, then it will be accepted convergence and if this statistic is smaller than lower critical value, then it will be rejected convergence existence (Bahmani oskoyi 2002).

Second stage includes estimation of equation and determination of estimate coefficient by use of ARDL method.

First: we apply two zero hypothesis (there isn't convergence state) and mutual hypothesis for convergence among variables.

$$H_1 : \delta_1 \neq 0, \delta_2 \neq 0, \delta_3 \neq 0, \delta_4 \neq 0$$

$$H_0 : \delta_1 = \delta_2 = \delta_3 = \delta_4 = 0$$

$$H_1 : \theta_1 \neq 0, \theta_2 \neq 0, \theta_3 \neq 0, \theta_4 \neq 0$$

$$H_0 : \theta_1 = \theta_2 = \theta_3 = \theta_4 = 0$$

Then it is tested hypothesis by obtaining statistic, and we decide. So in second stage, we apply ARDL method to estimate investment equation.

Second: there are four criteria to determine numbers of optimum pause which include: 1- Square criterion, 2- Akaike criterion (AIC), 3- Schwarz Bayesian (SBS) and 4- Hannan-Quinn criterion (HQC).

We choose one of these for criteria and estimate them by determine number of pauses. We basically try that there wouldn't be serial correlation (there isn't significant relation between disturbance components) in Diagnostic statistics (Static statistic); form of variance in identical function means that there are identical variances in various and different samples. To be normal suppose that disturbance components have normal distribution which we study it via error period and diagram and determine that are there above problems in data, as a result we solve them via different methods and finally we estimate real variables value (Bahmani oskoyi 2002).

ARDL method has been delivered by Pesaran et al (1996) to determine co-summation relation between variables. In this method, in spite of Yoo Hanson idea, it isn't needed to know degree of variables co-summation in model. Meanwhile, it is also determined number of sum vectors. In this method, to study co-summation relation between Xt and Yt variables, his estimated two equation types. The equation, which is dependent to Xt variable, is as follow:

(1)

$$\Delta x_t = \alpha_1 + \sum_{i=1}^k b_{i1} \Delta x_{t-i} + \sum_{i=1}^k c_{i1} \Delta y_{t-i} + \omega_1 x_{t-1} + \omega_2 y_{t-1} + \varepsilon_{1t}$$

Where  $\Delta$  is difference function such as X as dependent variable, Y as dependence vector,  $\varepsilon_1$  as

distribution term, t as time and K as the number of Akaike coefficient (AIC), Schwarz Bayesian (SBS), Hannan-Quinn (HQC) or  $R^{-2}$ . The coefficients of  $\alpha_1$ ,  $b_{i1}$ ,  $c_{i1}$ ,  $\omega_1$  and  $\omega_2$  are estimation able parameters.

X of equation which Yt is dependent variable is as follow:

(2)

$$\Delta Y_t = \alpha_2 + \sum_{i=1}^k b_{i2} \Delta x_{t-i} + \sum_{i=1}^k c_{i2} \Delta y_{t-i} + \omega_1 x_{t-1} + \omega_2 y_{t-1} + \varepsilon_{2t}$$

Where, Y is dependent variable, X is dependent variable and  $\varepsilon_2$  is disturbance term. The coefficients of  $\alpha_2$ ,  $b_{i2}$ ,  $c_{i2}$ ,  $\omega_1$  and  $\omega_2$  are estimation able parameters. The rest symbols have the same definition in relation (1).

In relation (1), Xt variable is dependent one, zero hypothesis is based on lack of long-term relation among variables.

We test ( $H_0: \sigma_1 = \sigma_2 = 0$ ) against opposite hypothesis ( $H_1: \sigma_1 \neq \sigma_2 \neq 0$ ) by use of F-test which we call FX (xy). But distribution of this F statistic, regardless I(0) or I(1) or to be independent variables model, is not standard. In this reason, Pesaran et al (1996) have given suitable critical amounts in respect to independent variables in model and existence or lack of width from origin or time trend. These statistics include two complexes (column). One complex has been calculated by propose these variables I(0) and another one by propose I(1) for all variables. If calculated F-statistic exceed from upper limit of critical amounts domain given by Pesaran et al, then we will reject zero hypothesis based on lack of long-term relation between variables. In this state it can be deduced that there is one-way causality relation from Xt variable to Yt one. If calculated F-statistic is less than lower limit in this domain, then we couldn't reject zero hypothesis and in this state, there isn't causality relation between variables. If calculated F-statistic is located inside critical amounts domain, it will be deduced in certain result. This procedure must be repeated for another equation.

### Generalized Dicky-Fuller test:

In this method, it is used first-degree differential terms with pause or auto-regression AR(p) to solve the correlation problem. The number of pauses are determined based on this point that disturbance term,  $u_t$  time series doesn't have serial correlation. This test can be stated as follow:

$$\Delta y_t = c + \beta_t + \alpha y_{t-1} + \sum_{i=1}^{p-1} \alpha_i \Delta y_{t-i} + u_t \quad u \approx iid (0, \delta^2)$$

$$H_0 : \alpha = 0$$

$$H_1 : \alpha < 1$$

In this test,  $H_0$  hypothesis implies existence of unit root and opposite hypothesis shows series stand. Therefore, if calculated t-statistic absolute value is larger than critical absolute value, this means to reject  $H_0$  hypothesis (existence of unit root). It is worth to point out that to select form (having time procedure and width from origin) and also suitable pause to test ADF in results are effective, so that increase in pause numbers will result in decrease test power; because, on one hand, it is increased the number of estimated parameters, and on the other hand, it is decreased the number of useful observation and therefore, Test power is also decreased by decrease in freedom degree.

**Discussion and Conclusion:**

It has been considered governmental investment pattern as follow general form:

$$SIA = F(ROG, SI, VA, Y, P)$$

SIA: Governmental investment in agriculture section

ROG: Petroleum incomes

SI: Capital stock with one pause in agriculture section

VA: Value-added

Y: National income

P: Inflation rate

It was used generalized Dicky-Fuller test to study governmental investment stability in agriculture section. It has been give ADF as it results in table (1). As table information show that all variables except petroleum incomes are in instability level and their first degree difference is stable. In another words, these variables of sum pattern is I(1) degree.

**Table (1): Results ADF test**

ADF	Variable first-order differencing	ADF	variable
-4.14	DSIA	-0.41	SIA
		-2.97	ROG
-3.74	DSI	-0.79	SI
-3.78	DVA	-0.74	VA
-3.25	DY	-0.43	Y
-4.762	DP	-0.81	P

Critical value of ADF statistic at 5% level: -2.97

It was conducted F-test in order to study long-term relation among governmental investment in agriculture section, petroleum income, capital stock

with one pause, national income and inflation rate which its results are demonstrated in table (3).

Table (2) shows upper and lower limits of critical amounts in 1% and 2.5% significant level, respectively which are given by Pesaran & Sheen (1996), thus because F-statistic is more than upper limit in 1 and 2.5 percent level, so it is rejected hypothesis of lack of long-term relation among pattern variables. In another words, there is long-term relation among governmental investment in agriculture section, petroleum income, capital stock, value-added, national income with one pause and inflation rate. It has been reported estimation results of long-and short-term coefficient by method of OLS in table (2). It has been determined optimum pause length in respect 2 Schwarz Bayesian test.

**Table (2): Results F test for the existence of long-term relationship**

At 97.5% level		At 99% level		F-statistic
I(0)	I(1)	I(0)	I(1)	
3.05	4.26	3.51	4.78	7.03

Source: Research Findings

**Table (3): The pattern of public investment in agriculture to UECM**

variables	Coefficient	t-statistic
C	52.316	2.291**
$DROG_{t-1}$	-0.190	-0.780
$DROG_{t-2}$	-0.373	-1.273
$DSI_{t-1}$	0.837	2.409**
$DSI_{t-2}$	0.472	0.895
$DVA_{t-1}$	3.910	2.834**
$DVA_{t-2}$	3.488	3.042***
$DY_{t-1}$	-0.331	-0.471
$DY_{t-2}$	-0.417	-0.546
$DP_{t-1}$	-1.190	-1.584
$DP_{t-2}$	0.195	0.389
$SIA_{t-1}$	-1.228	-4.218***
$ROG_{t-1}$	1.011	4.292***
$SI_{t-1}$	1.525	2.864**
$VA_{t-1}$	-2.127	-1.387
$Y_{t-1}$	1.629	2.228**
$P_{t-1}$	1.472	3.454***

\* Significant at 10% level, \*\*Significant at 5% level, \*\*\*Significant 1% level

The result of table (3) show that governmental investment in long-term is effected by itself with one pause. In another words, one previous period investment has negative and significant effect on governmental investment. Petroleum income, national income and capital stock in long-term have positive effect on governmental investment and are meaningful or significant statistically. Value-added is in significant statistically, but has negative effect on governmental investment, inflation rate has also positive and significant effect on state investment in long-term, so that the agriculture section institutions have mostly subsidize, therefore increase in inflation on their price is not so effective so increase in price cause to increase in profit from investment in agriculture section and also motivation for investing.

**Table (4): Results of the estimation elasticity's**

Variables	Elasticity
ROG	0.82
SI	1.24
VA	1.73-
Y	1.32
P	1.19

Based on information in table (4) it is observed that strengths of variables in petroleum income, capital stock with on pause, national income and inflation rate equal to 0.82, 1.24, 1.32 and 1.19 respectively, assuming the other conditions constant, if the rate of these variable increase as one percent, then the rate of governmental investment increase as 0.82, 1.24, 1.32 and 1.19 respectively. Also governmental investment decrease in as amount of 1.73 by one percent increase in value-added, also the results of table show that governmental investment has the most sensitive relative to value-added, so that one percent increase in value-added causes to decrease in 1.73 percent in governmental investment.

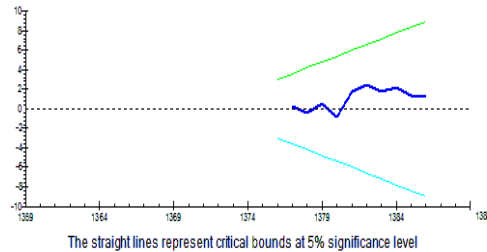
It was used Ramsey's reset test in order to study absent or present affirmation error, the results of test showed absent of affirmation error in pattern. Self-correlation test showed that there isn't self-correlation disturbance between terms. It was used cumulative sum (CUSUM) and cumulative sum of squares (CUSUMSQ) Braven et al (1975) in order to study estimated parameters stability.

In this test, in spite of some tests such as Chaw, it is not necessary to determine structural break point. Diagram 1 and 2 showed the result of this test. There two diagrams show that estimated parameters in pattern are stable.

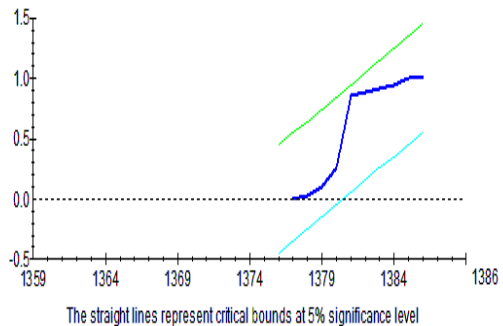
Estimation of long-term relation in public section investment by estimator of error correction model (ECM):

We enter long-term function the rest terms with one pause to short-term functions to study error correction model.

**Plot of Cumulative Sum of Recursive Residuals**



**Plot of Cumulative Sum of Squares of Recursive Residuals**



Governmental investment function short-term model in agriculture section is as follow:

$$\Delta(SIA)_t = 0.01 + 0.51\Delta(ROG)_t + 0.06\Delta(SI)_t + 1.17\Delta(VA)_t + 0.19\Delta(Y)_t + 0.13\Delta(P)_t - 0.69ECM(-1)$$

$$T: (0.25) \quad (4.27) \quad (0.31) \quad (1.66) \quad (0.52) \quad (0.42) \quad (-3.46)$$

$$R^2 = 0.77$$

$$F = 13.25$$

$$D.W = 2.00$$

$$\bar{R}^2 = 0.71$$

It is explained 0.71 percent of short-time changes of dependent variable by independent variable in this estimated equation, and term coefficient of error correction shows that it is

corrected 0.69 percent of lack of balance in next period in each one and modification is toward long-term.

**\*Corresponding Author:**

Seyed Nemat Allah Mousavi  
Department Of Agricultural Economics, Marvdasht  
Branch, Islamic Azad University, Marvdasht, Iran  
E-mail: mousavi\_sn@yahoo.com

**Resources:**

- 1- Amini, A. & N. Faihi. 1377. The study of investment situation in agriculture section. Plan and Budget Magazine. 33: 95-119.
- 2- Bagheri, M. & J. Torkamani. 1379. The study of situation and relation between private and public investment in agriculture section by use of co-cumulative test. Complex of Articles in Third Conference of Iran's Agriculture Economy. University of Ferdosi in Mashhad. 775-797.
- 3- Hojati, M. 1380. Agriculture development and investment security. Agriculture Economy and Development Magazine. 9(1): 7-13.
- 4- Khaledi, K., S. Yazdani, & A. Haghghat nejad shirazi. 1387. Study of Iran's rural poverty and determination of effective elements on it by emphasize to investment in agriculture section. Iran's Economical Researches magazine. 35(2): 205-228.
- 5- Salimifar, M. & M. Ghavi. 1381. Banks facilities and private investment in Iran. Iran Economical Researches Magazine. 13(4): 135-170.
- 6- Ghorbani, M., A. Shokri, & M. Motallebi. 1386. Application of in limited error correction pattern to determine effective elements on private investment in Iran. Knowledge and Development Magazin (Scientific-Research). 20(1): 111-124.
- 7- Kiani rad, A & M. Kopahi. 1379. Analysis of state or public investment in agriculture section and its anticipation for 1379-83 periods. Agriculture Economy and Development. 32(4): 103-116.
- 8- Hazhbar kiani, K. & M. Alizadeh. 1379. The study of effective elements or private section investment in Iran agriculture by use non-linear least- squares method. Development and Agriculture Economy. 29(1): 45-73.
- 9- Yusefi, M. & S. Aziznejad. 1388. The study of determinal elements in private investment in Iran by method of self-explanation. Economical Research Magazin. 1(1): 79-100.
- 10- Bahmani-Oskoe, M. & N.R. CHIwing. 2002. Long-run demand for money in Hongkong an application of the ARDL model. International Journal of Business and Economics. 2: 75-97.
- 11- Emran, M. SH., A.M. Imam, & SH. Forhad. 2003. After the license Raj economic liberalization and aggregate private investment in India. Economics Working Paper at WUSTL. 1-30.
- 12- Ghali, K.H. 2000. Some methodological comments on public investment and private capital formation in a vector error correction model of growth. Applied Economics. 7: 581-583.
- 13- Mizutani, F. & T. Takana. 2005. Productivity effects and determinants of public infrastructure investment, 45<sup>th</sup> congress of the European regional science association.
- 14- Petric, M. 2004. Farm investment credit rationing and governmentally promoted credit access in Poland: a cross-sectional analysis. Food Policy. 29: 275-294.

1/25/2012

## Effect factors on meat imports to Iran

Seyed Nematallah Mousavi, Mohammad reza Rezaei, Seyed Mohammad Reza Akbari

Department Of Agricultural Economics Marvdasht Branch, Islamic Azad University, Marvdasht, Iran

\*Corresponding author: [mousavi\\_sn@yahoo.com](mailto:mousavi_sn@yahoo.com)

**Abstract:** Foreign trade has always been an issue as important in the economies of the world that Iran was no exception. The import of meat in foreign countries to study the factors affecting the balance paid. Changes in short- and long-term study of factors affecting meat imports from Iran, with its pattern of regression with distributed lags (ARDL) Examined Information and statistical data base needed groceries and Agriculture Organization (FAO) and World Customs Organization and Central Bank of Iran, for the period 2008-1986 has been collected the results showed that changes. The results showed that the adjusted rate changes that support the policies of the Government in the short term and long term is the most important factor affecting the importation of meat.

[Seyed Nematallah Mousavi, Mohammad reza Rezaei, Seyed Mohammad Reza Akbari. **Effect factors on meat imports to Iran.** Life Science Journal 2012;9(1):374-377]. (ISSN: 1097-8135). <http://www.lifesciencesite.com>. 54

**Keyword:** Meat imports, supporting the delivery rate (APR), to explain the pattern of interruptions, (ARDL)

### Introduction

Today, trade in agricultural products due to the strategic nature of some of these products has become increasingly important with the growth of world trade (Kamijani, 2001). In recent decades, enjoying the benefits of foreign trade and in international markets as one of many of the factors affecting the economic development of developing countries (Akbarian, 2002).

Iran's exports of agricultural products the country imports relatively little comment, but in some cases affect the country's foreign trade. So much of the agricultural trade is that imports of agricultural products is considered strategic Hence the policy of self sufficiency in the production efficiency of the analysis Current methods of providing market information and in identifying are factors affecting agricultural crops. (Kamijani, 2001).

One of the most fundamental relationships between macroeconomic variables in the import demand function is Import demand in developing countries, the changes are fairly extensive.

The import demand is a function of several factors Coefficient of elasticity of the respective importance of these factors can be realized (Akbari and Bakhshodeh, 2002).

Khan(2001), In the latter case, the imbalance by adding a variable delay (with a continuous dependent variable) was investigated. Karen (1996), the overall import demand in the United States estimate that over the past two decades. Based on his results showed that import demand is a function of relative prices and real income.

Mohammadi (1999), Iran's pattern of demand for grain imports (rice, wheat, barley, corn), providing for the separation of the different countries examined He

uses the almost ideal demand system, concluded that demand for grain imports, especially wheat, barley and corn, according to the internal But much depends on the level and pattern of demand on rice prices have followed a process of and more a function of domestic price level is the product.

Parizan and Esmail (1988), Factors affecting demand for imports of animal products in their review Their results showed that imports of all products in response to changes in tariff rates, the price of oil revenue and domestic production is not the same.

Because of the importance of imports and the import of meat products in developing countries including India are influenced by government policy intervention. This study sought to analyze factors affecting the importation of any product focusing on the role of national government policies in 1996-2008.

### Research

In order to support government policies can be adjusted Rate (APR) that the total effect of policies that include (Bojnec, 1996). Direct and indirect effect of trade policy, price and exchange rate policies of major countries that has been spent.

Adjusted benchmark rate of protection is calculated as follows:

$$APRJ = (P_j^d * / P_j^b - 1) * 100 \quad (1)$$

Which  $P_j^d *$  is defined as follows:

$$P_j^d * = P_j^d / AER = P_j^d / (NER * USCPI / CPI) \quad (2)$$

In the above:

$P_j^d$ : domestic product prices to nominal exchange rate of \$ J, which has become America.

$P_j^b$ : price of product j in the reference country (America) dollars (border price)

$P_j^{d*}$ : price of domestic product adjusted for exchange rate

NER: Nominal exchange rate (which is equal to the market exchange rate)

AER: exchange rate adjusted

CPI: consumer price index for domestic

USCPI: America's consumer price index (the reference)

In this study factors affecting the demand for imports of meat to follow linear function of the import demand function in this capacity for reflection Behavior of domestic demand for beef imports were:

$$\text{LN}M_{IT} = \alpha_0 + B_1 \text{LN}(P_{IT}^C) + B_2 \text{LN}(R_{IT}) + B_3 \text{LN}(T_{IT}) + B_4 \text{LN}(Q_{IT}) + \mu_{IT} \quad (3)$$

Which In  $M_{IT}$  the value of imports of the product in T (Rials)  $P^C$  price index is the relative value of the share prices of imports on domestic prices has been? T levels of tariffs applied to product per year, Q the amount of production (per ton), R in foreign exchange revenues from oil exports.  $\mu$  is the random error is to assume a normal distribution and random. It also includes a zero mean and constant variance. In the above equation, T represents the year and I can show the goods.

Given the above model of import demand for red meat can be written as:

$$\text{LN} M_{IT} = \alpha_0 + B_1 \text{LN}(P_{IT}^C) + B_2 \text{LN}(R_{IT}) + B_3 \text{LN}(T_{IT}) + B_4 \text{LN}(Q_{IT}) + B_5 \text{LN}(APR_{IT}) \quad (4)$$

In Top PC and the expected negative effect of T and Q and R have a positive effect on imports? In addition to economic variables affecting imports, non-economic variables, including laws and regulations with a variety of restrictions on imports also effective.

It is noteworthy that in addition to tariff barriers, nontariff barriers, there is also some of the convention. In the case of agricultural products in most cases the tariff equivalent of non-tariff barriers are the negative parts. Thus, import tariffs for the negative effect of trade taxes on import growth; provide (Khalilian, 2003).

In order to evaluate the short-term and long-term relationships between the dependent variable and other explanatory variables of the model approach ARDL (distributive model to explain the delay) was used.

The main advantage of using the ARDL approach is that regardless of whether the explanatory variables are stationary in levels ( $I_{(0)}$ ) or be a difference between the static ( $I_{(1)}$ ) can also reposition the relationship between variables achieved they will be efficient and non-diagonal (Seddighi, 2000).

ARDL model was used in this study and data required for the period from 2008 to 1996 from various sources including the Food and Agriculture Organization statistical database (FAO) and World Customs Organization and the various central banks have been collected.

Model (P, q1, q2, ..., qk) ARDL model based on this study can be written as follows:

$$\alpha(L, P) M_T = \alpha_0 + \sum B_i(L, P) X_{IT} + U_T, \quad I = 1, 2, \dots, K \quad (5)$$

Where 0  $\alpha$  intercept  $M_t$  import demand, and L is the lag factor is defined as follows:

$$L^j M_t = M_{t-j}$$

The independent variables used in the vector  $X_t$  is the import demand function. So we have:

$$\alpha(L, P) = L - \alpha_1 L^1 - \dots - \alpha_p L^p, \quad B_i(L, q) = B_{i0} + B_{i1}L + B_{i2}L^2 + \dots + B_{iq}L^{iq} \quad (6)$$

$X_{it}$   $\cdot$  I the independent variable is based on the ARDL model the dynamics of the demand for imports of meat can be calculated as follows:

$$\text{LN}M_T = \alpha_0 + \sum B_i M_{t-1} + \sum \varepsilon_i \text{LN}P_{i(t-1)}^c + \sum \gamma_i \text{LN}R_{i(t-1)} + \sum \mu_i \text{LN}T_{i(t-1)} + \sum \theta_i \text{LN}Q_{i(t-1)} + \sum \phi_i \text{LN}APR_{i(t-1)} + \varepsilon_0 \text{LN}P_{it}^c + \gamma_0 \text{LN}R_{it} + \mu_0 \text{LN}T_{it} + \theta_0 \text{LN}Q_{it} + \phi_0 \text{LN}APR_{it} + U_{it} \quad (7)$$

In this equation, s, g, f, n, m, k, respectively, optimized for continuous variables APR,  $\phi$ , T, R,  $P_c$ ,  $M_t$  is. To estimate long-term relationship between variables of a two-step approach we want to use the following syntax. Despite the long-term relationship between variables in the first test will be reviewed. If the sum of the estimated coefficients in this interval is smaller than a dependent variable, a dynamic model of long-term trend is toward equilibrium. Therefore, to test the convergence hypothesis under test should be performed (Noforesti, 1999):

$$H_0: \sum \beta_i - 1 \geq 0 \quad H_1: \sum \beta_i - 1 < 0 \quad (8)$$

T statistic for testing the quantity required is calculated as follows:

$$t = \frac{\sum_{i=1}^q \beta_i - 1}{\sum_{i=1}^q \sigma_{\beta_i}}$$

If the critical value provided by Neberji, slightly smaller than the desired confidence level in computing the t statistic is, H0 is rejected and A long-term equilibrium relationship between variables in the model there. The long-term relationships between the variables in the model will apply.

$$M_t = M_{t-1} = \dots = M_{t-p} \quad X_{i,t} = X_{i,t-1} = \dots = X_{i,t-p}$$

In the words of the last q variable i is related to the interruption of long-term relationship between variables can be expressed as follows.

$$M_t = \alpha + \sum \beta_i X_i + V_i, \quad \alpha = \dots \quad (10)$$

$$\beta_i = \frac{B_i(1,q)}{\sum \beta_i}, \quad V_i = \dots \quad (11)$$

According to the above long-term relationship between red meat import demand function can be demonstrated as follows:

$$\ln M_t = \delta_0 + \delta_1 \ln P_t^c + \delta_2 \ln R_t + \delta_3 \ln T_t + \delta_4 \ln Q_t + \delta_5 \ln APR_t + N_{2t} \quad (12)$$

$$\Delta m_t = \Delta \alpha_0 - \sum \alpha_j \Delta M_{tj} + \sum \beta_{i0} \Delta x_{it} - \sum \sum \beta_{i,t-j} \Delta x_{i,t-j} - \alpha(1, P) ECT_{t-1} + U_t \quad (13)$$

In this regard, the first difference operator  $\Delta$  and  $\beta_{ij}, t-j, \alpha_j, t-j$  estimated coefficients of equation (5) are.  $(1, P) \alpha$  is the coefficient of error correction that can measure the speed of adjustment. Correction of error (ECT<sub>t-1</sub>) is as follows.

$$ECT = Ex_t - \alpha - \sum \beta_i X_{it} \quad (14)$$

**Results**

ARDL model considering the dynamics of import demand for red meat in relation (4) the dynamics of the ARDL (1, 1, 2, 2, 0, 2) demand for imports of meat, the criterion Schwarz - Beizin Up to 2 interval was

estimated taking into account, the results are shown in Table 1.

**Table 1. Results from estimating the dynamic model ARDL (1, 1, 2, 2, 0, 2)**

variable	coefficient	Standard error	T <sub>0</sub>
C	-160.8154	104.9043	-1.53
Log (-1)	0.573**	0.256	2.23
Log P <sup>c</sup>	2.546***	0.304	8.36
Log P <sup>c</sup> (-1)	-1.05	0.628	-1.68
Log r	0.007	0.254	0.028
Log R (-1)	1.107***	0.371	2.97
Log R (-2)	-1.034	0.506	-2.04
Log T	1.064	0.253	4.20
Log T (-1)	-0.865	0.220	-3.92
Log T (-2)	0.354**	0.144	2.45
Log Q	5.014	6.824	0.73
Log APR	94.246***	15.755	5.98
Log APR (-1)	-85.738***	22.309	-3.84
Log APR (-2)	13.687	12.049	1.13
F = 38.11 (0.000)		R <sup>2</sup> = 0.98	

Source: research findings. \* And \*\* and \*\*\* significance at 10 and 5 and 1 percent.

Using dynamic ARDL model coefficients in Table 1, long-term correlation between variables was tested. Due to the number equation (9) statistics were calculated for (4 -) and the quantity provided critical Benerji-dolado meters in 90% (45 / 3 -) and the larger the absolute value calculation for the absolute beginning of the crisis, the null hypothesis balk and a result of long-term equilibrium relationship between variables, the model is accepted.

The results of the estimation model based on long-term relationship(10) are shown in Table 2

**Table 2. Estimating the long-term results of the ARDL (1, 1, 2, 2, 0, 2)**

coefficient	variable	Standard error	T <sub>0</sub>
-376.78	C	276.869	-1.36
3.490***	Log p <sup>c</sup>	1.340	2.60
0.188	Log R	1.557	0.12
1.294	Log T	0.967	1.33
11.749	Log Q	16.32	0.71
52.00**	Log APR	24.726	2.10

Source: research findings. \* And \*\* and \*\*\* significant at respectively 10 and 5 and 1 percent

If red meat. The significance of the estimated coefficients can be mentioned meat imports to the state. This too makes the intervention price and other factors do not show their true import of meat. The convergence of a series of economic variables provides the basis of error correction models. Error correction model of

short-term fluctuations in the values of variables in relation to long term.

Meat import demand related to the equation error correction model based on equation (13) was estimated and the results in Table 3 are given.

**Table 3. Results of the estimated error correction model**

Variable	coefficient	Standard error	T <sub>0</sub>
dC	-160.815	104.904	-1.533
dLog p <sup>c</sup>	2.546***	0.304	8.36
dLog R	0.007	0.254	0.028
dLog R <sub>1</sub>	1.034**	0.506	2.044
dLog T	1.064***	0.253	4.204
dLog T <sub>1</sub>	-0.354***	0.144	-2.459
Log Q	5.014	6.824	0.734
dLog APR	94.246***	15.755	5.981
dLog APR <sub>1</sub>	-13.687	12.049	-1.533
ECT(-1)	-0.426	0.256	-1.66
<b>R<sup>2</sup> = 0.97</b>		<b>DW = 1.78</b>	

Source: research findings. \* And \*\* and \*\*\* significant at respectively 10 and 5 and 1 percent

Table 3, the coefficients of all the coefficients in the relative price of exports in foreign exchange earnings by subtracting first-order variables, second difference, Difference between first and second first order difference value and tariff rates have been significantly modified to support. The results indicate that the coefficient of error correction (ECTt-1) was significant and expected sign (negative) value represents the ratio 0.42 and show that 0.42 percent balances the value of the dependent variable import after a period of red meat is gone. What the above results can be summarized as follows.

- Adjusted rates that actually support the policies of government intervention during the study period is What short and long term have a significant positive effect, so we can say Policy actions the government has a direct impact on the value of imports of meat.
- Tariff rates in the short term in first order by subtracting the expected negative and significant impact on the value of imports But in the long term no significant effect on import demand.
- Revenue from oil exports in the short term in first order by subtracting the expected positive impact on import demand is significant but no significant long term impact.
- The relative price level in the short and long-term significant at 1%, no significant relationship with import demand.

### Suggestions

According to the results of government policies on imports of meat is a very influential factor. Hence the

dominant role of the state monopoly on imports of beef into product without In these circumstances, domestic suppliers because they cannot make decisions based on market mechanisms Suffer losses and reduced production in the long run, higher prices, consumer losses and social welfare is reduced. Since the aim of policies towards trade liberalization policies so Adjustment policies should be implemented in meat imports.

### \*Corresponding Author:

Seyed Nemat Allah Mousavi  
Department Of Agricultural Economics,Marvdasht  
Branch, Islamic Azad University, Marvdasht, Iran  
E-mail: mousavi\_sn@yahoo.com

### Reference

1. Akbarian, R., (2002). WTO and its implications on the economy.
2. Bakhshodeh, M., and A., Akbari, (1998). Iran's demand of imported goods using relatively ideal demand system. *Agricultural*. 30(1): 110-100.
3. Bojnec, j., F. M. swinnen. (1996). The pattern of agricultural price distortion in central and eastern Europe. Policy Research Group. Working paper no 2. katholieke university. Miljkovic, D. (2004). Trade liberalization and chaging companysation and quality of imports in japan beef import markets. Southern agricultural economics association. 2004 SAEA annual meetings in Tulsa. Ok lanama. 1-21
4. Khalilian, S., and Hosseini, S. M., and N, Kazhadi, (2003), Effects of economic liberalization policies on the agricultural sector's growth, *Bank Quarterly*, 20: 198-183
5. Kamijani, A., (2000). Drop Agricultural market access provisions in the General Agreement on Tariffs and Trade and its effects on the agricultural economy of Iran: Tehran: Institute for Studies and research planning and agriculture economy.
6. Khan, m. (1974). Import and Export Demand in Developing Countries. *IMF staff paper*. 11 (3): 25-147
7. Mohammad , H., (1999), estimated the demand for grain imports master's thesis, Department of Agriculture, Shiraz University.
8. Noforesti, M., (1999), unit root total in econometrics, First printing, Rasa Press.
9. Parizan, V., A., Esmaceli, (2007), Examine factors affecting import demand for dairy products in India. *Economy including agriculture*, 1(2): 65-47.
10. Pesaran, M. H. and B-Pesaran, (1997). Working with microfit 4.0: An introduction of econometrics. Oxford University press. Oxford.
11. Seddighi, H. and et. al, (2000). *Econometrics: A Practical Approach*,
12. Sunder land Business School. London.

1/22/2012



## Peripheral Blood Expression of Angiotensin II type 1- Receptor (AT<sub>1</sub>- R) as A Non Invasive Marker of Liver Disease Progression in Patients with Non Alcoholic Fatty Liver Disease

Mohammed A Rady<sup>1</sup>, Elhamy Abd Al Monem<sup>2</sup>, Mona A Shafie<sup>3</sup>, Maha Sabawy<sup>1</sup>, Nashwa Sheble<sup>1</sup> and Mona M Hassouna<sup>2</sup>

Departments of Hepatology<sup>1</sup>, Clinical Pathology<sup>2</sup>, National Liver Institute-Menoufyia University, Clinical Pathology<sup>3</sup>, Menoufyia Faculty of Medicine  
[aklrady@yahoo.com](mailto:aklrady@yahoo.com)

**Abstract:** Angiotensin-II (AT-II) has been suggested to play an important role in liver fibrogenesis. It induces hepatic stellate cell (HSC) proliferation and up-regulates the transforming growth factor beta expression via AT-II type 1 receptor (AT<sub>1</sub>-R) *in vitro*. There is accumulating evidence that renin-angiotensin system (RAS) does not only play an important role in the regulation of systemic hemodynamics but is also involved in hepatic inflammation and fibrogenesis. **Aim of the study:** is to evaluate the efficacy of AT<sub>1</sub>-R as a non-invasive marker of liver disease progression in patients with non alcoholic fatty liver disease (NAFLD). **Patients and methods:** This study was conducted on 62 NAFLD patients (33 with pure steatosis and 29 with non alcoholic steatohepatitis (NASH)). All evidenced by the liver biopsy histopathological features of NAFLD. Twenty potential liver transplant donors were selected as a control group. All patients and control group were subjected to the following:- fasting insulin, HOMA index of insulin resistance, and serum Angiotensin II (AG II). Serum AT<sub>1</sub>R mRNA AT receptor was measured by Real-Time PCR. **Results:** a positive correlation was found between AT<sub>1</sub>R mRNA with fasting insulin, HOMA index of insulin resistance and serum AG-II levels in NAFLD patients. While a negative correlation was found between AT<sub>1</sub>R mRNA and ALT or AST in NAFLD patients. No significant differences between the two subgroups of steatosis and NASH for the all tested parameters except for AG-II and AT<sub>1</sub> R mRNA that show a significant increase in NASH patients (p<0.01) for each. **Conclusion:** Increased expression of AT<sub>1</sub>R on circulating leukocyte subsets of NAFLD patients, suggesting its possible role in disease progression, and it could be used as a non invasive marker for disease diagnosis and prognosis. In the future, AT<sub>1</sub>R expression may be used as a follow up marker for monitoring of therapeutic efficacy of currently available agents.

[Mohammed A Rady, Elhamy Abd Al Monem, Mona A Shafie, Maha Sabaw, Nashwa Sheble and Mona M Hassouna. **Peripheral Blood Expression of Angiotensin II type 1- Receptor (AT<sub>1</sub>- R) as A Non Invasive Marker of Liver Disease Progression in Patients with Non Alcoholic Fatty Liver Disease.** Life Science Journal 2012; 9(1):378-386]. (ISSN: 1097-8135). <http://www.lifesciencesite.com>. 55

**Key words:** NAFLD, NASH, Angiotensin II type I receptor, antifibrotic therapy.

### 1. Introduction

The high prevalence and chronic nature NAFLD subsequently translates to a significant health burden for the general community. Non-alcoholic fatty liver disease (NAFLD) is considered the hepatic manifestation of metabolic syndrome (**Montecucco and Mach, 2008; Preiss and Sattar, 2008**). This disease refers to a spectrum of hepatic manifestations ranging from steatosis (fat accumulation in the liver), through non-alcoholic steatohepatitis (NASH) (hepatic steatosis and inflammation) and sometimes fibrosis towards advanced and irreversible fibrosis (hepatic cirrhosis) (**Adams et al., 2005 ; Ratziu et al., 2007**). NAFLD may be progressive resulting in cirrhosis that may be complicated by hepatocellular carcinoma and liver failure. Overall, about 5% of patients with NAFLD develop cirrhosis over an average of a seven year period with 1.7% dying from complications of liver cirrhosis (**Adams et al., 2005**).

The American Association for the study of Liver Diseases has defined NAFLD as a fat accumulation in the liver over 5-10% of the organ weight

(**Neuschwander-Tetri and Caldwell, 2003**). The prevalence of NAFLD in the developed countries ranges from 20 to 30% (**Jimba et al., 2005**).

NASH has been recognized as a major cause of liver fibrosis and it is included in a disease spectrum ranging from a simple steatosis to advanced fibrosis and cirrhosis (**Browning and Horton, 2004; Bataller and Brenner, 2005**). NASH is associated with both increased cardiovascular and liver related mortality (**Fan, 2008; Angulo, 2010**).

Although the pathogenesis of NASH is not well understood, the most important theory proposed to explain the development of this disease is the "two-hit hypothesis" (**Day and James, 1998**). Consistent with this theory, the first "hit" is the fat accumulation within the liver; this is associated with an "insulin resistance state." Then, the hepatic steatosis development into NASH is related to injury caused by oxidative stress and inflammatory cytokines (the second hit) (**Browning and Horton, 2004**). As a result, abnormal cytokine production within the liver may be playing an essential role in the pathogenesis of NASH.

There is accumulating evidence that renin-angiotensin system (RAS) does not only play an important role in the regulation of systemic hemodynamics but is also involved in hepatic inflammation and fibrogenesis (**Yokohama et al., 2004; Bataller et al., 2005**).

Angiotensin II (AG-II), which is mainly generated by angiotensin converting enzyme (ACE) and chymase, is a peptide that plays a crucial role in regulating blood pressure and sodium homeostasis via specific receptors including angiotensin II type 1 receptor (AT<sub>1</sub> R) (**Murphy et al., 1992**). Angiotensin II is recognized to induce hepatic inflammation and to stimulate a range of fibrogenic action, including cell migration, cell proliferation, secretion of proinflammatory cytokines, and collagen synthesis predominantly throughout AT<sub>1</sub> receptor (**Bataller et al., 2005**).

Furthermore, several reports indicate that AG-II is able to be generated by different cells in a variety of tissues, and its production is activated in certain pathological states associated with tissue repair (**Sun et al., 2000**). The mechanism postulated for fibrotic actions of AG-II seems to involve an important mediator of fibrous tissue formation such as transforming growth factor- $\beta$ 1 (TGF- $\beta$ 1) (**Yoshiji et al., 2001; Bataller et al., 2005**). Other Previous studies have showed that the inhibition of RAS significantly attenuates TGF- $\beta$ 1 expression and fibrosis in heart (**Toblli et al., 2003**), kidney (**Sun et al., 2000**), and liver (**Toblli et al., 2002**).

**Muñoz et al. (2006)** demonstrated that obese Zucker rat (OZR) show excessive fat accumulation in the liver together with an increased expression of AG-II, suggesting that local AG-II generation may contribute to the pathogenesis of NASH. Therefore, due to its biological properties, RAS is an important target to prevent fibrosis in chronic inflammatory states.

The better understanding of the underlying mechanisms involved in liver fibrosis makes effective antifibrotic therapy an imminent reality. However, treating this disease remains a challenge and, up to this moment, no antifibrotic agent has been approved for routine human use.

#### **Aim of the study:**

The aim of this study was to clarify the relationship between the expression of AT<sub>1</sub> R in blood samples and progression of NAFLD from simple steatosis to NASH reaching up to cirrhosis.

#### **2. Patients and Methods:**

This study was conducted on 62 NAFLD patients (35 males and 27 females, age range 30- 52 years) attending the outpatient clinic of the National Liver Institute, from March, 2009 till September 2010.

NAFLD diagnosis was based on the NAFLD histopathological features in liver biopsy, absence of hepatitis B and C viral markers, absence of autoantibodies indicative of autoimmune hepatitis, absent alcohol consumption. All patients had a bright liver at ultrasound scanning. NAFLD patients were further classified as 33 cases of pure steatosis and 29 cases as NASH by the criteria proposed by **Brunt et al. (1999)**.

Exclusion criteria: Hypertensive patients, patients with renal impairment, those with features of early cirrhosis and /or portal hypertension, patient with diabetes mellitus were excluded from both the study and control group.

All participants were subjected to complete medical and anthropometric examination. Body mass index (BMI) was calculated as weight (in kilograms) divided by height squared (meters squared). Waist circumference (at the nearest half centimetre) was measured at the midpoint between the lower rib margin and the iliac crest.

Twenty potential liver transplant donors matching age and sex of the patients were selected as a control group. They were negative for serological markers of hepatitis B and C, with normal ultrasonographic evaluation of their liver as well as histopathology of their liver biopsy.

#### **The following investigations were done for patients and control subjects:**

Venous blood samples were obtained after a fasting night, by use of heparinized tubes, and circulating leukocytes were isolated for subsequent studies. Samples of blood were collected in pyrogen free tubes, then centrifuged and the resulting serum was divided, aliquoted and kept at  $-70^{\circ}\text{C}$  until assayed.

An aliquot of blood was used to monitor lipid profile including: total cholesterol, low-density lipoprotein cholesterol (LDL-c), high-density lipoprotein cholesterol (HDL-c), triglycerides, fasting blood sugar, and to perform routine laboratory examinations (serum albumin, aspartate aminotransferase, alanine aminotransferase, gamma glutamyl transpeptidase and alkaline phosphatase). These tests were measured using COBAS Integra-400 autoanalyzer (Roche- Germany).

The determination of fasting insulin level was done using Diagnostic System Laboratories incorporation kits (DSL-10-1600 ACTIVE<sup>®</sup> insulin, enzyme linked immunosorbent assay (ELISA) kit, Texas- USA). It is an enzymatically amplified one step sandwich type immunoassay. The minimum detection limit is 0.26 uIU/ml, the intra- and inter-assay coefficient variations were 2.6% and 6.2% respectively. Standards, controls and samples were incubated with Horseradish Peroxidase (HRP) labeled

anti-insulin antibody in microtitration wells which were coated with another anti-insulin antibody, the assay was performed according to the manufacturer's instructions (**Rasmussen et al., 1990**).

The degree of insulin resistance was calculated from the homeostasis model assessment (HOMA). The HOMA index was calculated by the formula (**Emoto et al., 1999**):

$$\frac{\text{Fasting plasma insulin (uIU/ml)} \times \text{fasting plasma glucose (millimoles / liter)}}{22.5}$$

HOMA index >3 is a criterion of insulin resistance (**Machado and Cortez-Pinto, 2005**).

### Measurement of serum AG- II:

AG-II was measured using an ELISA kit from Usen Life Science Inc. Wuhan. Briefly, The microtiter plate provided in this kit has been pre-coated with an antibody specific to AG-II. Standards or samples are then added to the appropriate microtiter plate wells with a biotin-conjugated polyclonal antibody preparation specific for AG-II. Next, Avidin conjugated to Horseradish Peroxidase (HRP) is added to each microplate well and incubated. Then a TMB substrate solution is added to each well. Only those wells that contain AG-II, biotin-conjugated antibody and enzyme-conjugated Avidin will exhibit a change in color. The enzyme-substrate reaction is terminated by the addition of a sulphuric acid solution and the color change is measured spectrophotometrically at a wavelength of 450 nm. The concentration of AG-II in the samples is then determined by comparing the **O.D.** of the samples to the standard curve.

### Measurement of AT1R mRNA AT receptor by Real-Time PCR:

#### 1- Isolation of Polymorphnuclear Leukocytes:

Whole blood was allowed to sediment on dextran at 37°C for 30 minutes. Supernatant was recovered and PMNs were separated from peripheral blood mononuclear cells (PBMCs) by Ficoll-Paque Plus density-gradient centrifugation. Contaminating erythrocytes were eliminated by 10 minute hypotonic lysis in distilled water with added (g/L) NH<sub>4</sub>Cl 8.25, KHCO<sub>3</sub>1.00, and ethylenediamine tetraacetic acid (EDTA) 0.04. Cells were then washed 3 times in NaCl 0.15 M and resuspended in 1 mL phosphate buffered saline with added bovine serum albumin 0.1% (**Guasti et al., 2006**).

#### 2- RNA Isolation and Real-Time PCR Analysis of AT<sub>1</sub>R mRNA:

Total mRNA was extracted from 1 × 10<sup>6</sup> cells by a Total RNA Isolation Kit (Roche -Mannheim, Germany) and the amount of extracted RNA was estimated by spectrophotometry at 260 nm. Reverse transcription reactions were performed using the high-

capacity cDNA Archive Kit (Applied Biosystems, Foster City, California, USA). Briefly, 1 μg of total RNA, 1 μL of oligo dT-primer, and 1 μL of dNTPs were incubated at 65°C for 5 min, then 10 μL of a cDNA synthesis mixture was added and the mixture was incubated at 50°C for 50 min. The reaction was terminated by adding 1 μL of RNaseH and incubating the mixture at 37°C for 20 minute kept at -80°C until RNA extraction (**Marino et al., 2007**).

Real-Time PCR was performed by Roche LightCycler-2.0 TM (Mannheim, Germany) using the assay on demand kit for human AT<sub>1</sub>Rs (Applied Biosystems). Cycles included one for 2 minute hold (50°C) and one for 10 minute and 45 for 15 second cycles of denaturation (95°C). Raw data were analyzed by the machine software. Threshold cycle value (Ct) for human AT<sub>1</sub>Rs was used to calculate a linear regression line generated by performing serial dilutions (1:10; 1:50; 1:500; 1:1,000; 1:10,000) of the total mRNA obtained from human PMN. The values were then normalized for Ct values of 18S ribosomal RNA (**Guasti et al., 2008**).

### Statistical analysis

The data were statistically analyzed using SPSS computer program version 11, data were expressed as mean ± SD and differences between groups were analyzed by Mann-Whitney or ANOVA tests, while chi square or Fisher's exact test were used to compare categorical variables. Pearson's correlation coefficient was used to test the relationship between various variables.

### 3. Results:

All data were calculated as mean ±SD and compared in tables 1-4. Table (1) shows a significant increase of BMI, waist circumference, fasting glucose, fasting insulin and HOMA index (insulin resistance) in the NAFLD group compared to the control group, while the age showed no significant difference.

Table (2) shows a statistically significant increase in AST, ALT, ALP and GGT. Also, a highly significant increase in the serum levels of AG-II and AT<sub>1</sub> R mRNA expression was detected in the NAFLD group compared to the control group (Figure 1).

Table (3) shows no significant differences between the two subgroups for the all tested parameters except for AG-II and AT<sub>1</sub> R mRNA that show a significant increase in NASH patients (p<0.01) for each (Figure 1).

Table (4) shows a positive correlation between AT<sub>1</sub> R mRNA and fasting insulin, HOMA index of insulin resistance and serum AG-II levels in NAFLD patients. But, AT<sub>1</sub> R mRNA not correlated either to ALT or AST in NAFLD patients.

**Table (1): Comparison between NAFLD patients and control group**

Variables	NAFLD (n=62) Mean $\pm$ SD	Control (n=20) Mean $\pm$ SD	t- Test	p-value
Age (years)	41.2 $\pm$ 3.5	39.4 $\pm$ 4.2	3.01	>0.05
BMI (kg/m <sup>2</sup> )	32.6 $\pm$ 5.4	22.5 $\pm$ 3.7	4.12	<0.05
Waist circum. (cm)	96.2 $\pm$ 6.8	86.2 $\pm$ 5.4	4.08	<0.05
Fasting glucose (mg/dl)	92.7 $\pm$ 10.2	85.8 $\pm$ 8.7	3.98	<0.05
Fasting insulin (uIU/ml)	9.8 $\pm$ 2.4	6.9 $\pm$ 1.7	5.12	<0.05
HOMA index	4.06 $\pm$ 1.13	2.6 $\pm$ 1.3	6.23	<0.01

P>0.05 is non significant, p value <0.05 and p value <0.01 is significant

**Table (2): Comparison between NAFLD patients and control group**

Variables	NAFLD (n=62) Mean $\pm$ SD	Controls (n=20) Mean $\pm$ SD	t- Test	p-value
AST (U/L)	49.3 $\pm$ 12.6	22.7 $\pm$ 9.5	5.66	<0.05
ALT (U/L)	57.6 $\pm$ 19.8	26.7 $\pm$ 11.22	4.67	<0.05
ALP U/L)	63.2 $\pm$ 12.4	35.2 $\pm$ 8.6	4.63	<0.05
GGT (U/L)	58.4 $\pm$ 10.2	39.5 $\pm$ 7.6	5.01	<0.05
Albumin (g/dl)	3.97 $\pm$ 0.72	4.17 $\pm$ 0.62	3.22	>0.05
Triglycerides (mg/dl)	156.3 $\pm$ 45.6	134.1 $\pm$ 18.3	1.98	>0.05
Total cholesterol (mg/dl)	198.2 $\pm$ 33.4	177.4 $\pm$ 13.2	2.17	>0.05
HDL-Cholesterol (mg/dl)	36.5 $\pm$ 5.6	40.2 $\pm$ 6.7	3.23	>0.05
LDL-Cholesterol (mg/dl)	129.2 $\pm$ 31.4	102.6 $\pm$ 19.2	1.25	>0.05
AG-II (pg/ml)	23.6 $\pm$ 9.4	8.1 $\pm$ 1.7	7.56	<0.01
AT <sub>1</sub> R mRNA	9.84 $\pm$ 1.25	4.25 $\pm$ 1.67	5.81	<0.01

P>0.05 is non significant, p value <0.05 and p value <0.01 is significant

**Table (3) Comparison between steatosis and NASH patient subgroups**

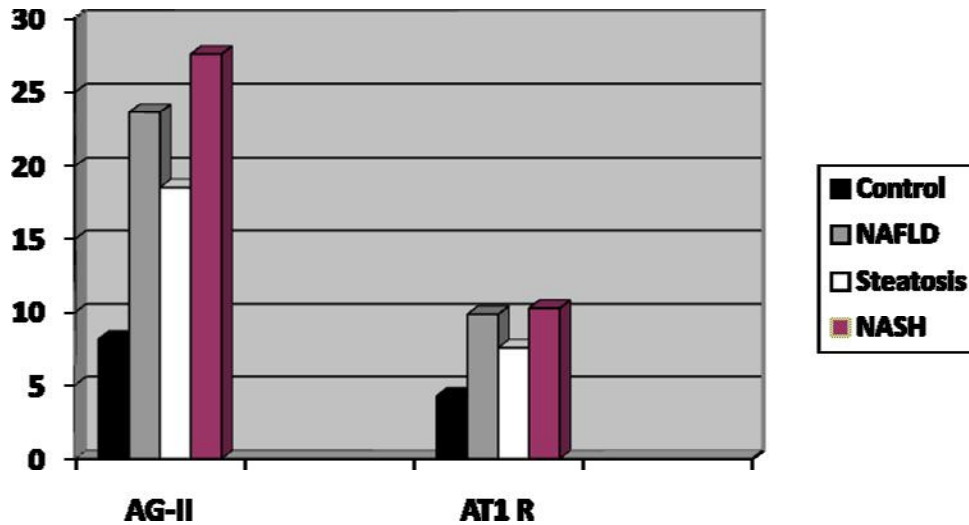
Variables	Steatosis (n=33) Mean $\pm$ SD	NASH (n=29) Mean $\pm$ SD	t- Test	p-value
BMI (kg/m <sup>2</sup> )	29.4 $\pm$ 4.1	34.5 $\pm$ 5.6	2.13	>0.05
Fasting Glucose (mg/dl)	92.8 $\pm$ 10.2	96.1 $\pm$ 6.54	2.03	>0.05
Fasting Insulin (uIU/ml)	9.1 $\pm$ 2.3	9.6 $\pm$ 2.4	1.68	>0.05
HOMA index	3.71 $\pm$ 0.98	3.92 $\pm$ 1.62	1.27	>0.05
AST (U/L)	39.8 $\pm$ 5.2	45.2 $\pm$ 12.4	3.06	>0.05
ALT (U/L)	51.3 $\pm$ 12.8	55.2 $\pm$ 10.2	2.62	>0.05
ALP (U/L)	56.5 $\pm$ 7.9	64.7 $\pm$ 10.8	2.26	>0.05
GGT (U/L)	50.2 $\pm$ 4.6	56.7 $\pm$ 9.5	1.67	>0.05
Albumin (g/dl)	3.65 $\pm$ 0.42	3.47 $\pm$ 0.23	1.12	>0.05
Triglycerides (mg/dl)	136.6 $\pm$ 25.9	144.1 $\pm$ 46.1	2.23	>0.05
Total cholesterol (mg/dl)	182.1 $\pm$ 21.5	209.1 $\pm$ 21.3	2.17	>0.05
HDL-Cholesterol (mg/dl)	31.5 $\pm$ 3.2	34.4 $\pm$ 6.4	1.03	>0.05
LDL-Cholesterol (mg/dl)	112.5 $\pm$ 21.3	132.3 $\pm$ 27.1	2.25	>0.05
AG-II (pg/ml)	18.5 $\pm$ 6.2	27.6 $\pm$ 4.3	5.13	<0.01
AT <sub>1</sub> R mRNA	7.42 $\pm$ 0.52	10.25 $\pm$ 1.31	5.12	<0.01

P>0.05 is non significant, p value <0.05 and p value <0.01 is significant

**Table (4) Correlation between AT<sub>1</sub> R mRNA and some parameters in NAFLD patients**

Parameters	NAFLD (N=62)	
	r	p-value
AST (U/L)	0.234	>0.05
ALT (U/L)	0.211	>0.05
Fasting Insulin (uIU/ml)	0.485	<0.05
HOMA index	0.692	<0.01
AG-II (pg/ml)	0.601	<0.01

P>0.05 is non significant, p value <0.05 and p value <0.01 is significant



**Figure (1): Shows the levels of Ang-II and AT<sub>1</sub> R mRNA in controls, NAFLD, steatosis and NASH patients.**

#### 4. Discussion:

Non-alcoholic fatty liver disease (NAFLD) and its severe clinical form, non-alcoholic steatohepatitis (NASH), are becoming increasingly prevalent in industrialised countries, along with the epidemic of obesity. The prevalence of NAFLD is estimated to be 10%-25% in the western world, while the corresponding prevalence of NASH ranges from 2%-7%. Insulin resistance and metabolic syndrome have been implicated both in the pathogenesis and disease progression of NAFLD (Tsochatzis and Papatheodoridis, 2011).11) pen

There is accumulating evidence that renin-angiotensin system (RAS) does not only play an important role in the regulation of systemic hemodynamics but is also involved in hepatic inflammation and fibrogenesis. Angiotensin II (AG-II) is recognized to induce hepatic inflammation and to stimulate a range of fibrogenic action, including cell migration, cell proliferation, secretion of proinflammatory cytokines, and collagen synthesis predominantly throughout AT<sub>1</sub> receptor (Toblli *et al.*, 2008).

The current study showed that a significant increase in BMI, waist circumference in NAFLD patients, a finding corresponds with two facts that NAFLD is strongly associated with metabolic syndrome and people with NAFLD have higher waist circumference (WC) or BMI than those without NAFLD (Jakobsen *et al.*, 2007 & Almeda-Valdes *et al.*, 2009).

Fasting blood sugar, fasting insulin and HOMA index of insulin resistance were found to be elevated in NAFLD patients in comparison with the control group. These are in agreement with the finding of Yoon *et al.*

(2005), who reported that NAFLD is associated with hyperinsulinaemia and insulin resistance in even non obese subjects. They suggested that insulin resistance is the most pathognomonic condition responsible for NAFLD. Also, Hui *et al.* (2003) stated that Insulin may injure the liver both directly and indirectly due to insulin's ability to generate oxidative stress or up-regulation of the lipogenic protein, sterol regulatory element-binding protein. It also seems to have direct profibrogenic effects by stimulating connective tissue growth factor, especially in the presence of hyperglycemia (Arthur & Mccullough, 2007).

As serum aminotransferases are markers of liver injury (despite their relative lack of sensitivity and specificity), they are often used as surrogate markers of disease activity (Promrat *et al.*, 2010). Angulo *et al.* (1999) reported that, mildly to moderately elevated serum levels of AST, ALT, or both are the most common and often the only laboratory abnormality found in patients with NAFLD. The ratio of AST to ALT is usually less than 1, but this ratio increases as fibrosis advances, leading to a loss of its diagnostic accuracy in patients with cirrhotic NAFLD (Pinto *et al.*, 1996).

The current study comes in accordance with this showing a significant increase in the levels of AST, ALT in NAFLD patients compared to the control group. On the other hand, comparing patients with simple steatosis and those with NASH in their transaminases levels, a non significant difference between them was found with still relatively elevated levels in NASH patients than those with only steatosis. This comes in accordance with the fact that normal serum aminotransferases or with intermittent elevations

on repeated studies, do not exclude NASH or advanced stages of disease (Mofrad *et al.*, 2003).

Detection of serum levels of GGT in patients of our study revealed significant elevations of this enzyme levels in NAFLD patients than controls. This comes in accordance with many studies revealing that an elevated GGT was the commonest biochemical abnormality in NAFLD patients and, unlike transaminases; this was associated with the presence of cirrhosis. Biochemical profiles that omit GGT will be inadequate in screening for NAFLD (Masterton & Hayes, 2010).

Interestingly, in our study, alkaline phosphatase was found to be significantly elevated in NAFLD patients than controls. Despite the absence of any bile duct damage or proliferation, elevated alkaline phosphatase was associated with activity, fibrosis and overall NAFLD severity. Possible sources of elevated alkaline phosphatase could be through modulation of bile acid transporters by inflammatory cytokines as in cholestasis, or simply by intrahepatic or peripheral neutrophils as part of the inflammatory response (Fisher *et al.*, 1989). Alternatively, a small percentage of patients, possibly as many as 10%, may present with an isolated elevated alkaline phosphatase. These patients tend to be older women with auto-antibodies, such as antinuclear antibodies, may be found in up to one third of patients (Mofrad *et al.*, 2003).

As regards serum albumin levels which were found within normal levels is agreed with Baldrige *et al.* (1995), who reported that, hypoalbuminemia is only expected in NAFLD patients with cirrhosis.

In this study, elevated triglycerides, total cholesterol, LDL with lowered HDL cholesterol were detected in NAFLD patients however, the difference between the NAFLD group and the control group was not statistically significant. This could be explained by the postulation that, hypertriglyceridemia, hypercholesterolemia, or both were present in only 20-80% of patients with NASH. Most patients with NASH have multiple risk factors; including obesity, type 2 DM, and hyperlipidemia (Tarantino *et al.*, 2007). Taken together with the fact that some of our healthy controls have levels of dyslipidemias on the high normal states, this condition may be accepted.

The serum biochemistries, including serum AST, ALT, alkaline phosphatase, cholesterol, triglyceride, and the grade of fatty changes at ultrasound did not show significant differences between the steatosis and NASH subgroups. Several studies of hepatology clinic patients undergoing liver biopsy and morbidly obese individuals undergoing bariatric surgery, have found ALT levels to be higher in the presence of NASH compared with simple steatosis, although this has not been universally observed. (Harrison *et al.*, 2000). Till now there is no reliable marker could be counted upon

in differentiation between simple steatosis and NASH except for liver biopsy.

The RAS is frequently activated in patients with chronic liver diseases. AT-II has been suggested to play an important role in liver fibrogenesis. It induces hepatic stellate cell (HSC) proliferation and up-regulates the transforming growth factor-beta 1 (TGF-beta 1) expression via AT<sub>1</sub> R. These results suggested that the RAS, especially AT-II and AT<sub>1</sub> R interaction plays a pivotal role in liver fibrosis development through HSC activation (Yoshiji *et al.*, 2001)

In spite of many studies regarding the development of fibrosis, the understanding of the pathogenesis remains obscure. The hepatic tissue remodeling process is highly complex, resulting from the balance between collagen degradation and synthesis. Among them any mediators that take part in this process, the components of the RAS have progressively assumed an important role. Angiotensin acts as a profibrotic mediator and Ang-(1-7), the newly recognized RAS component, appears to play a role in fibrogenesis (Pereira *et al.*, 2009).

In our study, with respect to the postulated role of the RAS system in liver inflammation and fibrosis, serum AG-II and AT<sub>1</sub> R mRNA were found to be significantly elevated in NAFLD patients than control group which opens the way to accept the postulated role of this system in the pathogenesis of NAFLD. Also a significant difference of serum AG-II and AT<sub>1</sub> R mRNA was found between the two subgroups of NAFLD and there was a progressive increase of serum AG-II and AT<sub>1</sub> R mRNA from patients of simple steatosis to NASH, the higher grade of NAFLD. An observation suggesting a big role of AG-II and AT<sub>1</sub> R mRNA in progression of NAFLD mainly incriminated in both inflammation and fibrosis development.

These results reinforce the previous information suggesting that Ang- II causes development and progression of NAFLD in the transgenic rat model by increasing hepatic respiratory oxidative stress (ROS). A finding which supports a potential role of RAS in prevention and treatment of NAFLD. This hypothesized role may be explained by increased hepatic oxidative stress due to increased RAS activity causes NAFLD to occur and progress (Yongzhong *et al.*, 2008). The RAS reportedly plays an important role in insulin resistance, and suppression of AT-II ameliorates insulin resistance (Yoshiji *et al.*, 2009). Comes with this postulation the positive correlation between AT<sub>1</sub> R mRNA and fasting insulin and HOMA index of insulin resistance which was detected in NAFLD patients of our study.

As many previous reports showing that AG II plays a major role in liver fibrogenesis (Yoshiji *et al.*, 2009), a further step using RAS blockade either by ACE inhibition or AT<sub>1</sub> receptor blockade preserves liver biochemical parameters together with a substantial

reduction in the liver injury. It is well known that both IL-6 and TNF- $\alpha$  are inflammatory cytokines that play a crucial role in the regulation of inflammatory responses. On this basis, the anti-inflammatory effects of anti-RAS therapy may be associated with a reduction in the local expression of these cytokines (Muñoz *et al.*, 2006). Consequently, blockade of RAS could be a new approach to prevent or to treat patients with NASH (Toblli *et al.*, 2007).

In spite what is mentioned by the previous studies that AG II induces hepatic inflammation suggesting an association between AG II signalling and hepatic inflammation, in the current study no correlation was found between serum levels of AG-II and AT<sub>1</sub> R mRNA and AST, ALT serum levels. These results could be explained as mentioned before that normal serum aminotransferases or with intermittent elevations on repeated studies, do not exclude ongoing NASH or advanced stages of disease (Mofrad *et al.*, 2003), and that serum aminotransferases are markers of liver injury despite their relative lack of sensitivity and specificity (Promrat *et al.*, 2010).

Angiotensin affects insulin signaling, and promotes inflammation, fibrosis and endothelial dysfunction. Suppression of AT-II by the clinically used angiotensin-converting enzyme inhibitor (ACE-I) and AT-II type I receptor blocker significantly attenuated the liver fibrosis development along with inhibition of the activated hepatic stellate cells (HSC) (Georgescu *et al.*, 2009 & Yoshiji *et al.*, 2009).

Angiotensin-II type I receptor blocker and iron chelator reportedly exert suppressive effects on non-alcoholic steatohepatitis (NASH) progression, including liver fibrosis and hepatocarcinogenesis. This combination treatment exerted a stronger inhibitory effect in comparison with treatment with a single agent. These inhibitory effects occurred almost concurrently with the suppression of oxidative stress, neovascularization, and HSC activation. The dual inhibition by combined treatment of AT<sub>1</sub> R blocker and iron chelator attenuated the progression of NASH. Since both agents are widely used in clinical practice, this combination therapy may represent a potential new strategy against NASH in the near future (A positive correlation between AT<sub>1</sub> R mRNA and fasting insulin and HOMA index of insulin resistance in NAFLD patients was detected (Kaoru *et al.*, 2008).

**Conclusion:** serum levels of AT<sub>1</sub> and AT<sub>1</sub> receptors were found to be progressively elevated in NAFLD patients starting from simple steatosis up to NASH reaching to liver cirrhosis. These postulations suggest a new role of AT<sub>1</sub> receptor as a diagnostic and prognostic reliable serum marker for NAFLD. More controlled randomized trials for treatment of NAFLD using new drugs should be done depending on the serum levels of AT<sub>1</sub> and AT<sub>1</sub> receptors as a diagnostic

and prognostic serum markers of NAFLD from steatosis cirrhosis.

#### Corresponding author

Mohammed A Rady  
Department of Hepatology<sup>1</sup>  
National Liver Institute-Menoufyia University  
[aklrady@yahoo.com](mailto:aklrady@yahoo.com)

#### References

- Adams LA, Lymp J, St Sauver J, *et al.* (2005). The natural history of nonalcoholic fatty liver disease: a population based cohort study *Gastroenterology*, 129:113–21.
- Almeda-Valdes P, Cuevas-Ramos D, Aguilar-Salinas CA (2009). Metabolic syndrome and non-alcoholic fatty liver disease. *Ann Hepatol.*, 8(S1): 18–24.
- Angulo P, Keach JC, Batts KP, Lindor KD (1999). Independent predictors of liver fibrosis in patients with nonalcoholic steatohepatitis. *Hepatology*, 30:1356–62.
- Angulo, P (2010). Long-term mortality in nonalcoholic fatty liver disease, is liver histology of any prognostic significance? *Hepatology*, 51: 373–375
- Arthur J. and McCullough (2007). Pathogenesis of Non-alcoholic Steatohepatitis: Human Data. *Open Access Clin Liver Dis.*, 11: 75–104
- Baldrige AD, Peres-Atayde AR, Graeme-Cook F, Higgins L, Lavine JE (1995). Idiopathic steatohepatitis in childhood: a multicenter retrospective study. *J Pediatr.*, 127:700–4.
- Battaller R, Brenner DA (2005). Liver fibrosis. *Clin Invest.*, 115:209–218.
- Battaller R, Sancho-Bru P, Gines P, Brenner DA (2005). Liver fibrogenesis: a new role for the renin-angiotensin system. *Antioxid Redox Signal*, 7:1346–1355.
- Browning JD, Horton JD (2004). Molecular mediators of hepatic steatosis and liver injury. *J Clin Invest.*, 114:147–152.
- Brunt EM, Janney CG, Di Bisceglie AM, Neuschwander-Tetri BA, Bacon BR (1999). Nonalcoholic steatohepatitis: a proposal for grading and staging the histological lesions. *Am J Gastroenterol.*, 94: 2467–2474.
- Chen SH, He F, Zhou HL, Wu HR, Xia C, Li YM. (2011). Relationship between nonalcoholic fatty liver disease and metabolic syndrome. *Journal of Digestive Diseases*. Volume 12, Issue (2): pages 125–130
- Cuevas-Ramos D, Aguilar-Salinas CA (2009). Metabolic syndrome and non-alcoholic fatty liver disease. *Ann Hepatol.*, 8(S1): 18–24.
- Day CP, James OF (1998). Steatohepatitis: a tale of two "hits"? *Gastroenterology*, 114:842–845.

15. Emoto M, Nishizawa Y, Maekawa K, Hiura Y, *et al.* (1999). Homeostasis model assessment as a clinical index of insulin resistance in type 2 diabetic patients treated with sulfonylureas. *Diabetes Care*, 22: 818–822.
16. Fan, J.G (2008). Impact of non-alcoholic fatty liver disease on accelerated metabolic complications. *J. Dig Dis.*, 9: 63–67
17. Fisher B, Keenan A M, Garra B S, Steinberg S M, White D E, DiBisceglie A M, Hoofnagle J H, Yolles P, Rosenberg S A, Lotze M T(1989). Interleukin-2 induces profound reversible cholestasis: a detailed analysis in treated cancer patients. *J Clin Oncol.*, 7: 1852–62.
18. Georgescu EF, Ionescu R, Niculescu M, Mogoanta L, and Vancica L (2009). Angiotensin-receptor blockers as therapy for mild-to-moderate hypertension-associated non-alcoholic steatohepatitis. *World J. Gastroenterol.*, 15: 942–954
19. Giovanni Tarantino, Gennaro Saldamacchia, Paolo Conca(2007). NAFLD: Further Expression of the Metabolic Syndrome: Prevalence of NAFLD. *J Gastroenterol Hepatol.*, 22(3):293-303. © 2007 Blackwell Publishing
20. Guasti L, Franca Marino I, Marco Cosentino I, *et al.*(2008). Prolonged statin associated reduction in neutrophil reactive oxygen species and angiotensin II type 1 receptor expression: 1-year follow-up. *European Heart Journal*, 29: 1118–1126
21. Guasti L, Marino F, Cosentino M, Cimpanelli ET AL A(2006). Simvastatin treatment modifies polymorphonuclear leukocyte function in high-risk subjects: a longitudinal study. *J Hypertens*,24:2423–2430.
22. Hui JM, Sud A, Farrell GC, Bandara P, Byth K, Kench JG, McCaughan GW and George J(2003).Insulin resistance is associated with chronic hepatitis C virus infection and fibrosis progression. *Gastroenterology*, 125: 1695–1704.
23. Jakobsen MU, Berentzen T, Sorensen TI, *et al.*(2007). Abdominal obesity and fatty liver. *Epidemiol Rev.*, 29:77–87
24. Jimba, S.; Nakagami, T.; Takahashi, M.; *et al.*(2005). Prevalence of non-alcoholic fatty liver disease and its association with impaired glucose metabolism in Japanese adults. *Diabet. Med.*, 22: 1141-1145.
25. Kaoru Iwata, Tetsuro Sohma, Makoto Irie, Yasuaki Takeyama, Akira Anan, Satoshi Shakado, Shotaro SakisakaKaoru I (2008). Angiotensin II Type 1 Receptor Antagonist Improves the Prognosis in Rats Displaying Liver Cirrhosis Induced by a Choline-Deficient Diet *J Gastrointestin Liver Dis.*, Vol.17 No (1): 21-25
26. Machado M and Cortez-Pinto(2005). Non-alcoholic fatty liver disease and insulin resistance. *Eur J Gastroenterol Hepatol.*, 17 (8): 823-826.
27. Marino F, Guasti L, Cosentino M, Lecchini S(2007). Angiotensin II type 1 receptor expression in polymorphonuclear leukocytes from high-risk subjects: changes after treatment with simvastatin. *J Cardiovasc Pharmacol.*,49:299–305.
28. Masterton G and Hayes P(2010). Pattern and significance of biochemical abnormalities in referrals to a NAFLD clinic. *Gut* ,59:A24
29. Matteoni CA, Younossi ZM, Gramlich T, *et al.*(1999). Nonalcoholic fatty liver disease: a spectrum of clinical and pathological severity. *Gastroenterology*, 116:1413-9.
30. Miriam E. Tucker(2011). "NAFLD detected in 19% of obese youth". *Internal Medicine News. FindArticles.com.*
31. Mofrad P, Contos MJ, Haque M, *et al.*(2003). Clinical and histological spectrum of nonalcoholic fatty liver disease associated with normal ALT values. *Hepatology*, 37:1286-1292.
32. Montecucco, F.; Mach, F(2008). Does non-alcoholic fatty liver disease (NAFLD) increase cardiovascular risk? *Endocr. Metab. Immune. Disord. Drug Targets*, 8: 301-307.
33. Muñoz MC, Argentino DP, Dominici FP, *et al.*(2006). Irbesartan restores the *in-vivo* insulin signaling pathway leading to Akt activation in obese Zucker rats. *J Hypertens.*,24:1607–1617.
34. Murphy TJ, Takeuchi K, Alexander RW(1992). Molecular cloning of AT1 angiotensin receptors. *Am J Hypertens.*,5:236–42S.
35. Neuschwander-Tetri, B.A.; Caldwell, S.H(2003). Nonalcoholic steatohepatitis: Summary of an AASLD Single Topic Conference. *Hepatology*, 37: 1202-1219.
36. Pereira RM, da Costa Dias FL and Simões e Silva AC(2009).Renin-angiotensin system in the pathogenesis of liver Fibrosis. *World J Gastroenterol.*, 15(21): 2579-2586.
37. Pinto HC, Baptista A, Camilo ME, *et al.*(1996). Nonalcoholic steatohepatitis: clinicopathological comparison with alcoholic hepatitis in ambulatory and hospitalized patients. *Dig Dis Sci.*,41:172-9.
38. Preiss, D.; Sattar, N(2008). Non-alcoholic fatty liver disease: an overview of prevalence, diagnosis, pathogenesis and treatment considerations. *Clin. Sci. (Lond)*. 115: 141-150.
39. Promrat K, Kleiner DE, Niemeier HM, Jackvony E. *et al.* (2010). Randomized controlled trial testing the effects of weight loss on nonalcoholic steatohepatitis. *Hepatology*, 51: 121–129



40. Rasmussen H, Zawalick KC, Ganesan S, Calle R, Zawalich WS(1990). Physiology and pathophysiology of insulin secretion. *Diabetes Care*, 13: 655-666.
41. Ratziu, V.; Bugianesi, E.; Dixon, J.; Fassio, E.; Ekstedt, M.; Charlotte, F.; Kechagias, S.; Poynard, T.; Olsson, R(2007). Histological progression of non-alcoholic fatty liver disease: a critical reassessment based on liver sampling variability. *Aliment. Pharmacol. Ther.*, 26: 821-830.
42. Ratziu V, Giral P, Charlotte F, *et al.*(2000). Liver fibrosis in overweight patients. *Gastroenterology*, 118:1117-23.v
43. Satapathy S and Sanyal(2010). Novel treatment modalities for nonalcoholic steatohepatitis. *Metabolism, Trends Endocrinol Metab.* 21(11):668-75. Vol. 21, No. (11):668-75
44. Sun Y, Zhang J, Zhang JQ, Ramires FJ(2000). Local angiotensin II and transforming growth factor-beta1 in renal fibrosis of rats. *Hypertension*, 35:1078-1084.
45. Toblli JE, Muñoz MC, Cao G, Mella J, Pereyra L, Mastai R. (2008). ACE Inhibition and AT1 Receptor Blockade Prevent Fatty Liver and Fibrosis in Obese Zucker Rats. *Obesity*, 16: 770-76.
46. Toblli JE, DeRosa G, Rivas C *et al.* (2003). Cardiovascular protective role of a low-dose antihypertensive combination in obese Zucker rats. *J Hypertens* 21:611-620.
47. Toblli JE, Ferder L, Angerosa I, *et al.*(2002). Enalapril prevents fatty liver in nephrotic rats. *J Nephrol.*,15:358-367.
48. Tsochatzis E and Papatheodoridis Gpen(2011). Is there any progress in the treatment of non-alcoholic fatty liver disease? *Gastrointest Pharmacol Ther.*, 2(1): 1-5
49. Yokohama S, Yoneda M, Haneda M *et al.*(2004). Therapeutic efficacy of an angiotensin II receptor antagonist in patients with non-alcoholic steatohepatitis. *Hepatology*, 40:1222-1225.
50. Yongzhong W.(2008). Angiotensin II-induced non-alcoholic fatty liver disease is mediated by oxidative stress in transgenic TG(mRen2)27(Ren2) rats. *J Hepatol.*, 49(3): 417-428.
51. Yoon D, Lee SH, Park HS, Lee JH, *et al.*(2005). Hypoadiponectinemia and insulin resistance are associated with nonalcoholic fatty liver disease. *J Korean Med Sci.*, 20(3): 421-426.
52. Yoshiji H, Kuriyama S, Yoshii J *et al.*(2001). Angiotensin-II type 1 receptor interaction is a major regulator for liver fibrosis development in rats. *Hepatology* 34:745-750.
53. Yoshiji, Ryuichi Noguchi, Yasuhide Ikenaka *et al.*(2009). Losartan, an angiotensin-II type 1 receptor blocker, attenuates the liver fibrosis development of non-alcoholic steatohepatitis in the rat. *World J Gastroenterol.*,5; 2:70.

## Power output and Efficiency of internal combustion engine based on the FTT theory

Reza Masoudi Nejad

Young Researchers Club, Islamic Azad University, Shahrekord Branch, Shahrekord, Iran  
[Reza.masoudinejad@gmail.com](mailto:Reza.masoudinejad@gmail.com)

**Abstract:** Typically, in an internal combustion engine, thousands of cycles are performed in a minute. In this sequence of cycles many physical and chemical quantities change from cycle to cycle. For example, the combustion heat changes due to residual gases, imperfect combustion and other reasons. In this work, we present two finite-time thermodynamics models for both an Otto and a Diesel cycle, in which the cyclic variability is studied as occurring in the heat capacities of the working fluid. The fluctuations considered are of the uncorrelated type (uniform and gaussian) and one correlated case (logistic map distribution). We find that in the correlated fluctuations case, the power output and the efficiency of both cycles reach bigger fluctuations than in the uncorrelated cases. This result can provide insights over the performance of internal combustion engines.

[Reza Masoudi Nejad. **Power output and Efficiency of internal combustion engine based on the FTT theory.** Life Science Journal. 2012;9(1):387-390] (ISSN:1097-8135). <http://www.lifesciencesite.com>. 56

**Keywords:** internal combustion engine; cyclic variability; fluctuations

### 1. Introduction

In 1996, Badescu and Andresen proposed that finite-time thermodynamics (FTT) can be complemented with some probabilistic concepts allowing a more accurate description of the performance indicators of a power system. These authors studied a continuous flow tube reactor which supplies heat to an engine from a chemical reaction with linear kinetics. In general, typical FTT-models of thermal cycles are worked in steady state and only one cycle is taken as representative of all the other cycles pertaining to a sequence of them. In a typical internal combustion engine, several thousands of cycles are performed in a minute and there exist theoretical and experimental reasons to expect important variations from one cycle to the next. These variations can be found for example in the combustion heat of an Otto cycle. In a recent paper, Daw et al. proposed a discrete engine model that explains how both stochastic and deterministic features can be observed in spark-ignited internal combustion engines. These authors present a model which reproduces the experimental observations of the cyclic variability of the combustion heat in a four-stroke, spark-ignition Otto cycle. Recently, we have reported an irreversible Otto cycle model including chemical reactions. In that model, we analyzed the performance of an Otto engine (see Fig. 1) taking into account power losses due to a kind of lumped friction and we also consider the combustion reaction at the end of the adiabatic compression. In other work, we took the concept of fluctuant combustion heat proposed by Daw et al. as the input of our irreversible Otto cycle model, and then we analyze the behavior of performance outputs, such as the

power (P) and the efficiency ( $\eta$ ) of the Otto cycle model.

In that work, we found that the size of the fluctuations in P and  $\eta$  around their mean values can be driven by the size of the combustion heat fluctuations and also by thermodynamic properties of the states of the working fluid. In the present work, we study two thermal cycles, namely the Otto and the Diesel cycles, under heat fluctuations, but using an alternative approach, where the fluctuations are taken as occurring in the heat capacity of the working fluid. In our approach, we take two previous FTT- models for both the Otto and the Diesel cycles. The paper is organized as follows: in Sec. 2, we present a brief resume of our previous thermal cycle models; in Sec. 3 we discuss our fluctuant models and finally in Sec. 4 we present the conclusions.

### 2. Preliminaries

In Fig. 1 we depict the Otto cycle pressure-volume diagram of the processes followed by the working fluid consisting of n moles of air. In Ref. 7 it was considered that both the “absorbed” heat  $Q_{eff}$  and the rejected heat  $Q_{out}$  occur at finite times given by

$$t_{1V} = K_1(T_3/T_2)$$

and (1)

$$t_{2V} = K_2(T_4/T_1)$$

respectively, where  $K_1$  and  $K_2$  are constants linked to the mean variation rate of the temperatures. In this approach the adiabatic processes were taken as approximately instantaneous, as it is common in

FTT-models [9]. In this way, the cycle's period is given by,

$$\tau = t_{1V} + t_{2V} = K_1 (T_3 - T_2) + K_2 (T_4 - T_1). \quad (2)$$

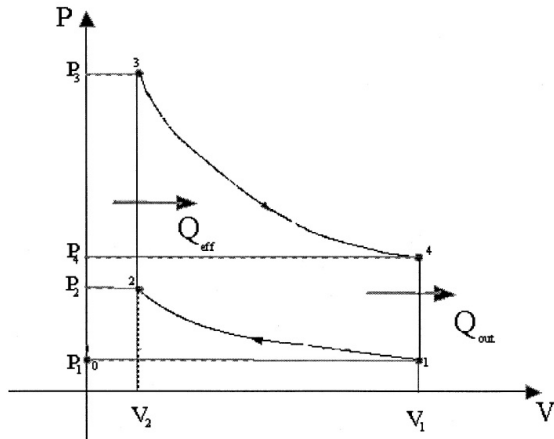


Figure 1. Pressure-volume diagram of an ideal Otto cycle.

In Ref. 7 the cycle's power output without losses was taken as

$$P_R = \frac{W_{TOT}}{\tau} = \frac{C_{v_1} - C_{v_2} r^{1-\gamma}}{K_1 - K_2 r^{1-\gamma}} \quad (3)$$

where  $C_{v_1}$  and  $C_{v_2}$  are the constant-volume heat capacities of air in both isochoric processes  $2 \rightarrow 3$  and  $4 \rightarrow 1$ , and  $\gamma = C_{p_1} / C_{v_1} = C_{p_2} / C_{v_2}$ , being  $C_{p_1}$  and  $C_{p_2}$  the constant pressure heat capacities of the working fluid during the processes  $2 \rightarrow 3$  and  $4 \rightarrow 1$  respectively,  $r = V_1 / V_2$  is the so-called compression ratio. When in the model, losses due to friction, turbulence in the working fluid, heat leaks etc, are added, all of them lumped in only a friction-like term, we have [7]

$$P_\mu = -\mu v^2 = -b(r-1)^2 \quad (4)$$

where  $\mu$  is a lumped friction coefficient that embraces all the global losses,  $v$  is the piston speed and  $b = \mu x_2^2 / \Delta t_{12}^2$ , being  $x_2$  the piston position at minimum volume  $V_2$  and  $\Delta t_{12} = \tau / 2$  the time spent in the power stroke. Thus, the Otto model effective power output is given by

$$P = P_R - P_\mu = \frac{C_{v_1} - C_{v_2} r^{1-\gamma}}{K_1 - K_2 r^{1-\gamma}} - b(r-1)^2, \quad (5)$$

and the cycle's efficiency by

$$\eta = \frac{P}{Q_{eff} / \tau} = 1 - \frac{C_{v_2} r^{1-\gamma} - b(r-1)^2}{C_{v_1}} (K_1 - K_2 r^{1-\gamma}) \quad (6)$$

Equation (6) reduces to  $\eta_0 = 1 - r^{1-\gamma}$  (the ideal Otto efficiency) for  $C_{v_1} = C_{v_2}$  and  $\mu = b = 0$  and Eq. (5) reduces to  $P = 0$  for the ideal reversible (infinite-time) case. Also, for the cycle's period,

$$\tau = K_1 (T_3 - T_2) + K_2 (T_4 - T_1) \quad (7)$$

and for the lumped friction losses

$$P_\mu = -b(r_c - 1)^2 \quad (8)$$

where  $r_c$  is the compression ratio  $r_c = V_1 = V_2$  and  $b = \mu x_2^2 / \Delta t_{12}^2$ . The effective power output and the cycle's efficiency are given by [8]

$$P = \frac{C_p (r_c - r_E) (r_E r_c)^{\gamma-1} - C_v (r_c^\gamma - r_E^\gamma)}{K_1 (r_c - r_E) (r_E r_c)^{\gamma-1} - K_v (r_c^\gamma - r_E^\gamma)} - b(r_c - 1)^2 \quad (9)$$

and

$$\eta = 1 - \frac{r_E^\gamma - r_c^\gamma}{\gamma (r_E - r_c) (r_E r_c)^{\gamma-1}} - \frac{b(r_c - 1)^2 [K_1 (r_E - r_c) (r_E r_c)^{\gamma-1} + K_2 (r_E^\gamma - r_c^\gamma)]}{C_p (r_E - r_c) (r_E r_c)^{\gamma-1}} \quad (10)$$

where  $C_p$  is the constant-pressure heat capacity and  $r_E = V_1 / V_3$  is the expansion ratio. Eq. (10) immediately reduces to the ideal Diesel efficiency [10] when  $\mu = b = 0$  and Eq. (9) reduces to  $P = 0$  for the ideal reversible case.

As it was remarked in Refs. 7 and 8, Eqs. (5), (6), (9) and (10) have a reasonable behavior when they are compared with real power and efficiency curves for actual Otto and Diesel engines. In fact, the obtained values for  $P_{max}$  and  $\eta_{max}$  in both cases are close to the real  $P_{max}$  and  $\eta_{max}$  values. In addition, these equations lead to loop-shaped curves for  $P$  versus  $\eta$  plots as it is common in many real engines [11].

### 3. The Otto cycle case

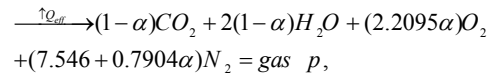
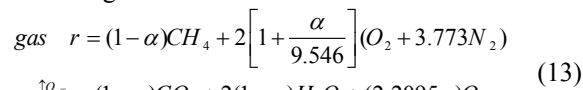
In this case, we assume that the intake mixture (gas  $r$ ) is composed by methane and air according to the following expression:

$$\text{gas } r = (1 - \alpha) CH_4 + 2 \left[ 1 + \frac{\alpha}{9.546} \right] (O_2 + 3.773 N_2) \quad (11)$$

where  $\alpha \in [0,0.1]$  determines the proportions of methane and air in the intake mixture, that is, it defines a mixture poor or rich in fuel contents. The molar number  $n_r$  of gas r is determined by the initial state of the mixture taken as ideal gas:

$$n_r = \frac{P_1 V_1}{\bar{R} T_1}; \tag{12}$$

if we take  $T_1 = 350K$ ,  $P_1 = 1.03 \times 10^5 Pa$ , and  $V_1 = 4 \times 10^{-4} m^3$ , which are typical values of P, V, and T [12] for an initial state in an Otto cycle, with  $\bar{R} = 8.31451 J mol^{-1} K^{-1}$  the universal gas constant, we have,  $n_r = 0.01415 mol$ . When the combustion reaction occurs, gas r [Eq. (11)] is converted in gas p according to



where  $Q_{eff}$  is the combustion heat.

In Figs. 2a, 2b and 2c we show the power output time series for three cases of fluctuations in the heat capacity  $C_{v,r}$ . For the efficiency case, and using the same three noisy inputs (uniform, gaussian and logistic), we obtain similar results, as can be seen in Figs. 3a, 3b, 3c.

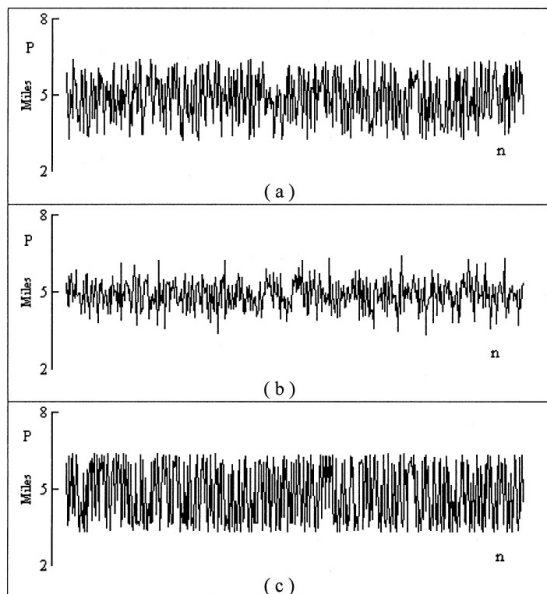


Figure 2. Power output fluctuations of the Otto cycle model: a) Uniform; b) Gaussian; c) Logistic

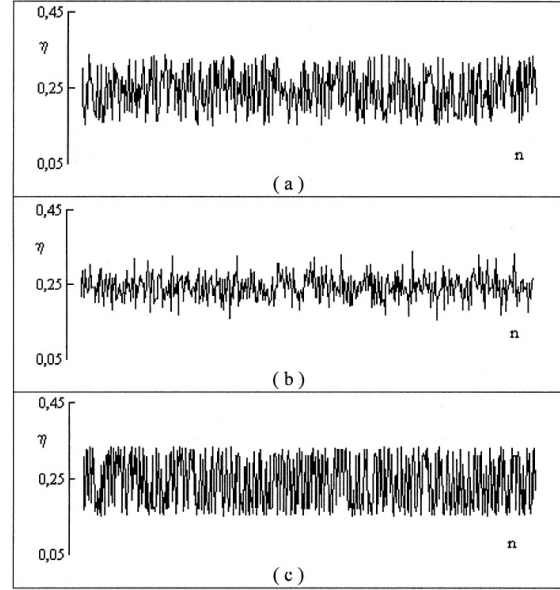


Figure 3. Efficiency fluctuations of the Otto cycle model: a) Uniform; b) Gaussian; c) Logistic

#### 4. Conclusion

There exist many theoretical and experimental reasons for taking a sequence of thermal cycles no as an identical repetition of a representative steady-state cycle, but as a sequence of cycles changing in several thermodynamic quantities. In fact, in internal combustion engines, as the Otto and Diesel engines, the combustion heat changes from cycle to cycle due to imperfect combustion and residual gases inside the cylinder after each combustion event. Evidently, this cyclic variability in the combustion heat must produce changes in the performance of a cyclic sequence, for example, in both the power output and efficiency. Recently, Daw et al. [3] proposed an internal combustion engine model, in which, the combustion heat changes from cycle to cycle. Those authors obtained a reasonable reproduction of the experimental time series of the fluctuant combustion heat for a spark-ignited Otto engine. Starting from this model, we proposed another model [6] in which, the fluctuant combustion heat drives the thermodynamics of an Otto engine including a chemical combustion reaction, and dissipative losses. In that work [6], we find that power and efficiency are fluctuant quantities whose fluctuation sizes (standard deviation and relative fluctuation) can be driven through the managing of the thermodynamic state variables of the working fluid [6]. In the present work, we develop fluctuant models for both an Otto and a Diesel cycle, but assuming that the cyclic variability can be lumped through the fluctuations of the constant-volume heat capacity. In both cases we have obtained that the size

of fluctuations is bigger in a logistic correlated noise than in two uncorrelated noises (uniform and gaussian), that is, in the case when the time series qualitatively resembles the situation in which combustion residuals are maintained from cycle to cycle.

#### Acknowledgements:

The author acknowledge the financial support from Young Researchers Club for this work.

#### Corresponding Author:

Reza Masoudi Nejad  
Islamic Azad University  
Shahrekord Branch  
Shahrekord, Iran  
E-mail: [Reza.masoudinejad@gmail.com](mailto:Reza.masoudinejad@gmail.com)

#### References

1. V. Badescu and B. Andresen, *J. Non-Equilib. Thermodyn.* 21 (1996) 291.
2. V.N. Lukanin, *Motores de Combustión Interna*. (Mir, Moscu, 1988).
3. C.S. Daw, M.B. Kennel, C.E.A. Finney and F.T. Connolly, *Phys Rev. E* 57 (1998) 2811.
4. C.S. Daw, C.E.A. Finney and M.B. Kennel, *Phys Rev. E* 62 (2000) 1912.
5. F. Angulo-Brown, T.D. Navarrete-Gonzalez and J.A. Rocha-Martinez, *Recent Advances in Finite-Time Thermodynamics*. C. Wu, L. Chen and J. Chen, Editors (NOVA Science Publisher. Inc., Commack New York, 1999) 491.
6. J.A. Rocha-Martínez, T.D. Navarrete-González, C.G. Pavía-Miller and F. Angulo-Brown, (2001) (submitted).
7. F. Angulo-Brown, J. Fernández-Betanzos and C.A. Díaz-Pico, *Eur. J. Phys.* 15 (1994) 38.
8. R. Paez-Hernández and F. Angulo-Brown, *Rev. Mex. Fis.* 42 (1996) 684.
9. M.H. Rubin, *Phys. Rev. A* 19 (1979) 1272.
10. M.W. Zemanzky and R.H. Dittman, *Heat and Thermodynamics* (Mc. Graw-Hill, New York, 1987).
11. J. Gordon and A.M. Huleihil, *J. Appl. Phys.* 72 (1991) 829.
12. M. Mozurkewich and R.S. Berry, *J. Appl. Phys.* 53 (1982) 34.
13. J.B. Heywood, *Internal Combustion Engine Fundamentals* (Mc Graw Hill, New York, 1988).
14. C.F. Taylor, *The internal-combustion engine in theory and practice* (M.I.T. Press., Cambridge Massachusetts, 1971).
15. S. Sieniutycz and A. De Vos, Editors, *Thermodynamics of Energy Conversion and Transport* (Springer-Verlag, New York, 2000).
16. D. Kaplan and L. Glass, *Understanding Nonlinear Dynamics* (Springer-Verlag, New York, 1995).
17. H.O. Peitgen, H. Jurgens and D. Saupe, *Chaos and Fractals* (Springer-Verlag, New York, 1992).

11/20/2011

## Relationship between Family Environment and Emotional Intelligence: Examination of the Moderating Factor

Fataneh Naghavi<sup>1</sup>, Marof Redzuan<sup>2</sup>

<sup>1</sup>School of Humanities and Social Sciences, Science and Research Branch, Islamic Azad University, Tehran, Iran.

<sup>2</sup>Department of Social and Development Sciences, Faculty of Human Ecology, University Putra, Malaysia.

<sup>1</sup>E-mail: [ahlo\\_1359@yahoo.com](mailto:ahlo_1359@yahoo.com), <sup>2</sup>E-mail: [Marof@putra.upm.edu.my](mailto:Marof@putra.upm.edu.my)

**Abstract:** Although a bulk of literature indicates that family environment influence emotional intelligence, the level of education as one of the important determinants which buffers this effect received little empirical attention. The current study investigated the moderating role of father's education on the relationships between family environment and emotional intelligence among 234 early adolescents (girls and boys) in grades 2 and 3 of guidance schools of Tehran, Iran. Data were collected using the Emotional Quotient Inventory Youth Version (Bar- on EQ-i; YV, 2000) and the Moos and Moos Family Environment Scale. Results revealed that family environment fostered emotional intelligence in their early adolescents. Furthermore, the findings demonstrated that father's education moderated the relationship between family environment and emotional intelligence. Specifically, early adolescents tended to indicate more emotional intelligence at higher levels of family environment when fathers have high level of education. These findings underscore the need for continued focus on the role of parent's education when assessing the links between family environment and early adolescent's emotional intelligence.

[Fataneh Naghavi, Ma'rof Redzuan. **Relationships between Family Environment and Emotional Intelligence: Examination of the Moderating Factor**. Life Science Journal 2012;9(1):391-395].(ISSN:1097-8135). <http://www.lifesciencesite.com>. 57

**Key Words:** Early Adolescent; Family environment; Emotional intelligence; Emotional Quotient Inventory Youth Version; Father's education; Education moderated; Moderating factor

### 1. Introduction

The concept of Emotional Intelligence is a complex phenomenon that occurs in early adolescent. It is found to lead to strong personal relationships (Cooper, 1997) and to improve pro-social behavior and self-management skills in early adolescent (Bar-On & Parker, 2000). Research indicates that early adolescent who are able to regulate their emotional reactions in response to others' emotions are more likely to have good social skills and to act pro-socially (Eisenberg & Fabes, 1997). The emotional intelligence construct is a relatively new concept with little empirical research, particularly related to the link between five specific sub-components of the early adolescent's emotional intelligence, their family environment and father's education.

There has been a growing interest in the emotional functioning of early adolescents (Goleman, 1995; Bar-On & Parker, 2000; Stover, 2003) and the factors that influence it (Carson & Parke, 1996; Eisenberg et al., 1996; Mayer & Salovey, 1997; Saarni, 1999) in order to develop more integrated theories of development (Bar-On, 2000; Stover, 2003). On the other hand, emotional intelligence is associated with factors such as life satisfaction, adaptability, optimism, overall intelligence, personality, and

emotional disorders like alexithymia, depression (Naghavi, Ma'rof & Mariani, 2010).

Gottman (1997) pointed that good parenting requires not only intellect but also involves emotion. In the last decade or so, science has discovered a tremendous amount about the role emotions play on our lives. Researchers have found that even more than IQ, emotional awareness and ability to handle feelings will determine success and happiness in all lifestyles, including family relationships. For parents, this quality of emotional intelligence as many now call it means being aware of early adolescence's feelings, and being able to empathize, soothe, and guide them. For early adolescence, who learn most lessons about emotion from their family, it includes the ability to control impulses, delay gratification, motivate them, read other people's social cues, and cope with life's difficulties. In addition, early adolescence whose parents consistently practice emotion coaching have better physical health and score higher academically than early adolescence whose family do not offer such guidance.

Yeh (1999)'s study which suggested that the students with parents receiving higher education exhibit higher emotional intelligence. Goleman (1995) presents the higher of parents' education level, the higher of children's emotion. It shows the

significant difference between the education of their parents' and the emotional intelligent. According to Goleman over half of interpersonal success is because of emotion regulation and expression. Consequently, considering the potential influences on emotional intelligence may be useful and vital. If numerous factors are found to influence emotional intelligence, then individuals can find ways to enhance emotional intelligence and subsequent lifelong achievement (Rippeth, 2002). This process is undoubtedly one of the importance ways that led to individual and social development (Naghavi, 2011).

In raising emotional intelligence among early adolescents, it is important to study what factors that contribute to the development of this construct. Parents are viewed as major contributors to early adolescent's emotional intelligence (McClun & Merrell, 1998). In all cultures, families are recognized as a fundamental influence for their children's and adolescents' well-being (Rotter, 1966). Parents who are approving and responsive tend to build emotional intelligence, whereas disapproving, unresponsive and uninterested parents may develop emotional intelligence in their early adolescents (Salovey & Mayer, 1990; Magnuson, 2007). Therefore, familial influences on emotional intelligence have enduring effect throughout life. However, associations between family environment and early adolescent outcomes might vary when the level of education as one of the ecological factors is taken into account. Research provide evidence indicating that parents with higher educational attainment tend to indicate more family system maintenance and use child-rearing strategies that highlight self-direction (autonomy) interpersonal skills and emotion regulation (Salovey & Mayer, 1990; Dornbush et al., 1990; Aavik et al., 2006).

Nonetheless, studies have generally looked at the direct relationships between family environment and early adolescents' outcomes (Magnuson, 2007; Cohen et al., 2008) and largely ignoring the moderating or indirect influence of education on these relationships. Hence, the main focus and contribution of this study is to examine how father's level of education moderates the relationships between family environment and early adolescents' emotional intelligence. Besides that, it is necessary to further examine the specific conditions under which these moderating effects exist. Examining these interactions is another important contribution of this research.

## 2. Materials and Methods

Participants included 234, 11-14th grade students (mean age = 12.27±1.26 years) from selected guidance schools in the 19 educational regions in the

city of Tehran. There were approximately equal proportions of male and female participants. Less than one-sixth (15.4%) of the fathers had little or no formal education, (55.5%) of fathers received a high school certificate or less, (11.3%) of the sample had some college education, and (17.8%) received a Bachelors degree or completed some graduate school.

At the beginning of the first semester of 2010-2011, the researcher visited all in grades second and third of Tehran's guidance schools and before distribution of questionnaires, a brief explanation regarding the aim of the study and the content of the instruments were given to the students. The questionnaire was divided into three parts. The first part of the questionnaire covered background information, the second part included the Family Environment Scale and the Bar-On EQ-i:YV followed by a scale which assessed the respondent's emotional intelligence. Furthermore, the backward-forward translation procedure was used to translate the instruments into Farsi. This procedure performed by two native-speakers of the target language. Then translations are compared and checked by a third consultant, and discrepancies are solved by consensus. Students answered the questions in the class, and they were reminded that participation was voluntary, and their responses did not have any influence on their grades.

For Demographics informaten fathers completed a demographic form including information about level of family income, fathers' level of education and age, and adolescents filled out the questions about their date of birth and gender.

Family Environment was assessed via the Family Environment Scale (FES), which is development by Moos (1974). It consists of 90 true/false questions divided into three dimensions and 10 subscales. In the Relationship dimension are three subscales: cohesion, expressiveness, and conflict. The Personal Growth dimension consists of five subscales: independence, achievement orientation, intellectual-cultural orientation, active-recreational orientation, and moral-religious emphasis. The System Maintenance dimension includes two subscales: organization and control. This instrument has good internal consistency with alphas that range from 0.74 to 0.87 for three subscales and the overall stability is very good with two-week test-retest reliabilities that range from 0.77 to 0.92 (Hill, 1995). In the current study, the internal consistency was 0.71, 0.74, and 0.75 for the Relationship, Personal Growth, and System Maintenance subscales respectively.

The Emotional Quotient Inventory Youth Version (Bar-On EQ-i:YV, 2000) using for assessing early adolescent's emotional intelligence. This scale consists of 60 brief items and a five-point Likert style

format response set (ranging from "Not True of Me" to "True of Me"). The Bar-On EQ-i instrument consists of the following five scales. Each scale briefly described as follow. The first scale, intrapersonal, involves the ability of the individual to understand their emotions as well as communicate and express feelings and needs. The second scale, interpersonal, measures one's ability to form and maintain satisfying relationships with others. The adaptability scale involves measuring one's ability to manage. The fourth scale, stress management, includes one's ability to remain calm in the face of stressful events. The general mood scale measures optimism and positive outlook. Finally, the total EQ scale is a measure of one's ability to be effective in dealing with daily demands while remaining happy or satisfied.

The first step in ascertaining a respondent's EQ-i:YV results was to calculate raw five composite factors and each child's total emotional intelligence. Each item is assigned with "points" ranging from one to five based on the respondent's responses. In this study, the internal consistency (reliability) of the EQ-i:YV was examined using the Cronbach's alpha and the result was  $\alpha = 0.90$ . Reliability indicates the extent to which individual differences in test scores are attributable to "True" differences in the characteristics under consideration (Anastasi, 1988). A test-retest reliability of 0.72 was found with a group of eleven graders. A Spearman-Brown split-half reliability of 0.76 was found for grades eleven through fourteenth. In this study, a Spearman-Brown split-half reliability was 0.72.

### 3. Results

Following the scientific research tradition, the level of confidence for all calculations was set at alpha 0.05. An intercorrelation matrix was produced between all predictor variables and the criterion variable for the total sample as presented in Table 1. Overall, the results from the correlation analyses as illustrated in the correlation matrix identified significant relationships between some of the independent variables and the dependent variable. Specifically, the variables of father's education and emotional intelligence had significant negative relationship, which suggested that as Specifically, the variables of father's education and emotional intelligence had significant negative relationship, which suggested that as father's education increased, emotional intelligence also, tended to decreased. Contrary to expectations, no statistically significant direct relationships were found between emotional intelligence and any of the family environment except family system maintenance. The negative correlation between family system maintenance and

emotional intelligence showed that early adolescents tended to have emotional intelligence when they perceived their fathers as highly system maintenance.

Hierarchical multiple regression analysis was conducted to examine whether father's education moderated links between family environment and emotional intelligence. On the first Step of the hierarchical regression analysis, father's education was entered, followed by family environment -system maintenance, personal growth and relationship-on Step 2 and two-way interactions on Step 3.

As it has been shown in Table 2, the interaction variables at Step 3, accounted uniquely for an additional 1.7 of variance to adolescent's emotional intelligence ( $F_{\{7,374\}} = 19.468, p \leq 0.001$ ). Examination of the variables within the third block revealed that the interaction between family system maintenance family environment and father's education was significant ( $\beta = -0.10, p \leq 0.05$ ).

Post-hoc regression analyses were performed in accordance with standards outlined by Aiken and West (1991) to evaluate possible differences for the only significant interaction variables namely, family system maintenance  $\times$  father's education. The values of high and low corresponding to one standard deviation above the mean and one standard deviation below the mean have been used in plotting significant interaction. Examination of these interaction effects at two levels of father's education demonstrated that family system maintenance was significantly related to emotional intelligence for early adolescents whose fathers have high education ( $b = -0.148, t = -3.894, p \leq 0.001$ ). This finding suggested that family system maintenance was most useful for early adolescents when father's education is high, however it is not significant when paternal education was low. Figure 1 provides a graphic example of the interaction effects of system maintenance and father's education in predicting emotional intelligence.

### 4. Discussion

The purpose of the present study is to examine the moderating role of father's education on the relationship between family environment and emotional intelligence. Even though some of these variables have been explored individually among predominantly Western and Caucasian early adolescents (Shumow & Miller, 2001; Paguio, 1987; Sorkhabi, 2005; Flouri, 2006), the combination of these factors and the role they may play in Iranian guidance school settings represent a novel contribution to the literature.

The first hypothesis, regarding family environment and its relation with emotional intelligence, was partially supported. The results demonstrated that family system maintenance was related to emotional



intelligence. This is consistent with the findings of previous research which have shown that family system maintenance promote emotional intelligence (Magnuson, 2007; Marsiglia et al., 2007). Our findings also revealed that neither the main effect of father's personal growth nor relationship family significantly predicted emotional intelligence. However, the direction of these results support those found by Nowicki and Segal (1974) that possible antecedents to emotional intelligence could be traced to the parent-child relationship.

The second hypothesis, regarding the moderating effect of father's education on the relationship between family system maintenance and emotional intelligence was also supported. Additional analyses revealed that fathers with high education and high family system maintenance, tended to foster more emotional intelligence in their early adolescents. This finding is consistent with the previous research which indicates that the amount of guidance schooling that family receive positively impacts on how they structure their home environment as well as how they interact with their early adolescents in promoting positive outcomes such as academic achievement (Davis-Kean & Eccles, 2005; Lifshitz, 1975; Shumow & Miller, 2001). In addition, Lifshiz (1975) assumed that emotional intelligence is influenced by the educational atmosphere. Therefore, it could be

concluded that fathers with higher educational level can nurture a belief in their early adolescents to affect the outcomes. They may put more emphasis on their early adolescents' responsibility in organizing relations with their environment which leads them to develop more emotional intelligence.

The present study makes several contributions to the literature by providing data on an important and understudied population of early adolescents and by bringing together a number of different constructs (family environment, emotional intelligence, and father's education) that have typically only been explored individually or in pairs in the past (Marey & Salovey, 1997; Wiltfang et al., 1990). This study suggests that family system maintenance plays a vital role in the development of emotional intelligence, and the level of education is probably significant within this population.

The current study includes several limitations which need to be considered in future research. The focus here on family system maintenance begs for replication in future research with both mothers and fathers, in order to observe any unique associations that may be present across gender of the parents. Future research should also attempt to observe results directly from families, in regard to their family environment instead of relying strictly on students' self-report design.

**Table1: Correlations between Major Study Variables (N=234)**

Variables	1	2	3	4	5
1. Father's education	-				
2. Relationship	0.03	-			
3. Personal Growth	0.06	-0.14*	-		
4. System Maintenance	0.19**	0.20*	0.085	-	
5. Emotional Intelligence	-0.47**	0.04	0.05	-0.30**	-

\*  $p < 0.05$ ; \*\*  $p < 0.01$

**Table2: Hierarchical Multiple Regression Analyses for Predicting Early Adolescents' Emotional Intelligence from Family Environment, and Father's Level of Education (N=234)**

Predictor	R <sup>2</sup>	Δ R <sup>2</sup>	B
Step1	0.199**		
Father's education			-0.446**
Step 2	0.260**	0.052**	
Relationship			0.104*
Personal Growth			0.103*
System Maintenance			-0.213**
Step 3	0.277*	0.019*	
Relationship x education			-0.003
Personal Growth x education			-0.085
System Maintenance x education			-0.099*

\*  $p < 0.05$ , \*\*  $p < 0.001$

**Corresponding Author:**

Dr. Ma'rof Redzuan Department of Social and Development Science, Faculty of Human Ecology,

University Putra Malaysia, 43400 Serdang, Selangor, Malaysia. Tel: +600389467064  
[marof@putra.upm.edu.my](mailto:marof@putra.upm.edu.my)

## References

1. Cooper, K. Applying emotional intelligence in the workplace. *Training & Development, Journal of Psychology*, 1997; (5): 31-39.
2. Bar-On, R., & Parker, J. D. A. *The handbook of emotional intelligence: theory, development, assessment, and application at home, school, and in the workplace.* Jossey-Bass, San Francisco, 2000.
3. Eisenberg, M. & Fabes, R. Parents' reactions to children's negative emotions: Relations to children's social competence and comforting behavior. Auburn House, Westport CT, 1997.
4. Stevens G. W. J. M., W. A. M. Vollebergh, T. V. M. Pels and A. A. M. Crijnen. Parenting and internalizing and externalizing problems in Moroccan immigrant youth in the Netherlands.
5. Goleman, D. *Emotional Intelligence.* New York: Bantam Books, 1995.
6. Carson, & Parker, J. F. Mothers' and fathers' socializing behaviors in three contexts: Links with children's peer competence. *Journal of Experimental Child Psychology*, 1996.44.
7. Stover, J. Fathers' Meta-Emotion and children's social status, Doctoral dissertation, Seattle Pacific University, USA, 2003.
8. Salovey, P., & Mayer, J. D. Emotional intelligence. *Imagination, Cognition, and Personality*, 1990;(9):185-211.
9. Saarni, C. *The Development of Emotional Competence.* New York: The Guilford Press, 1999.
10. Bar-On, R. *Emotional and Social Intelligence: Insights from the emotional quotient inventory.* San Francisco: Jossey-Bass Inc, 2000.
11. Naghavi, Fataneh, R. Ma'rof., and Mariani, M. The relationship between alexitymia and emotional intelligence. *Asian Social Science*, Published by Canadian Center of Science and Education, 2010; (6), 11:166-170.
12. Gottman, J. *Raising an Emotionally Intelligent Child: The heart of parenting.* New York: Simon & Schuster 1997.
13. Yeh, P. L. The relationship among demographic variables, intelligence, critical thinking and emotional intelligence of junior high school students. national sun Yat-Sen university, Taiwan. 1999.
14. Goleman, D. *Emotional Intelligence: Why It Can Matter More Than IQ.* New York: Bantam, 1995.
15. Naghavi, Fataneh. Family functioning and early adolescents' psychopathology. *World Applied Sciences Journal* 15, 2011.1512-1517.
16. McClun, L. A. and K. W. Merrell. Relationship of perceived parenting styles, locus of control, and self-concept among junior high age students. *Psychology in the Schools*, 1998;(35): 381- 392.
17. Rotter, J. B. Generalized Expectancies for Internal Versus External Control of reinforcement. *Psychological Monographs; General and Applied*, 1966;(80): 1-28.
18. Magnuson, K. Maternal education and children's academic achievement during middlechildhood. *Developmental Psychology*, 2007;(6):1497-1512.
19. Dornbush, S.M., P.L. Ritter, R. Mont-Reynaud and Z. Chien. Family Decision making and academic performance in a diverse high school population. *Journal of Adolescent research*, 1990; (5):143-160.
20. Aavik, A., T. Aavik, and J. K rgesaar. Parenting practices and personal values comparisons between parents of institutionalized and non- institutionalized adolescents. *TRAMES*, 2006;(1): 44-56.
21. Cohen, E., G. Biran, A. Aran, and G. T. Varda. Locus of control, perceived parenting style, and anxiety in children with cerebral palsy. *Journal of developmental and physical disabilities*, 2008; (20): 415-423.
22. Shumow, L., & Miller, J. D. Parents' at-home and at-school academic involvement with young adolescents. *The Journal of Early Adolescence*, 2001;(21):68-91.
23. Paguio, L., B. Robinson, P. Skeen, and J. Deal. Relationship between fathers' and mothers' socialization practices and children's locus of control in Brazil, the Philippines, and the United States. *Journal of Genetic Psychology*, 1987; (148): 303- 313.
24. Sorkhabi, N. Applicability of Baumrind's parent typology to collective culture: analysis of cultural explanations of parent socialization effects. *International Journal of Behavioral Development*, 2005;(29): 552-563.
25. Flouri, E. Parental interest in children's education, children's self-esteem and locus of control, and later educational attainment: Twenty-six year follow-up of the 1970 British Cohort. *British Journal of Educational Psychology*, 2006; (76): 41-55.
26. Marsiglia, C. S., J. J. Walczyk, W. C. Buboltz, and D. A. Griffith-Ross. Impact of parenting styles and locus of control on emerging adults' psychosocial success. *Journal of emotion and human development*, 2007;(1):1.
27. Nowicki, S. and W. Segal. Perceived parental characteristics, locus of control. *Developmental Psychology*, 1974;(10): 33-38.
28. Davis-Kean, P. E. and J. S. Eccles. Influences and barriers to better parent-school collaborations. Patrikakou, E. N., Weissberg, R. P., Manning, J., Walberg, H. J., & Redding, S. (Eds.) *School-family partnerships: Promoting the social, emotional, and academic growth of children.* New York: Teachers College Press, 2005.
29. Lifshitz, M. Social differentiation and organization of the Rorschach in fatherless and two parented children. *Journal of clinical psychology*, 1975;(31):126-130.
30. Mayer, J., D., Salovey. *What is a Emotional Intelligence? Emotional Development and Emotional Intelligence: Implications for educators.* New York: Basic Books, 1997.
31. Wiltfang, G.L., Scarbecz, M. Social class and adolescents' self-esteem: Another Look, *Social Psychology Quarterly*, 1990;(53): 174-183.

1/25/2012

## Relationships between Family Functioning, Alexithymia and Emotional Intelligence among Early Adolescents in Tehran-Iran

Fataneh Naghavi<sup>1</sup>, Marof Redzuan<sup>2</sup>

<sup>1</sup>School of Humanities and Social Sciences, Science and Research Branch, Islamic Azad University, Tehran, Iran.

<sup>2</sup>Department of Social and Development Sciences, Faculty of Human Ecology, University Putra, Malaysia.

<sup>1</sup>E-mail: [ahlo\\_1359@yahoo.com](mailto:ahlo_1359@yahoo.com), <sup>2</sup>E-mail: [Marof@putra.upm.edu.my](mailto:Marof@putra.upm.edu.my)

**Abstract:** With respect to the relationship between family functioning, alexithymia, and the early adolescent's emotional intelligence construct is still being developed with empirical support. Hence, this research follows a specific objective for determination of the relationship between family functioning, alexithymia, and early adolescent's emotional intelligence (EQ). EQ is a set of abilities such as conception, emotion appraisal and expression, emotion management and regulation, and emotion utilization of emotion. The present study was carried out among 234 Iranian students in the second and grades of guidance schools (age 12-15) in Tehran, Iran. The students (girls and boys) were clustered through random and multistage sampling. Data were collected using the Schutte's (1998) Emotional Intelligence Scale and Rieffe's Children's Alexithymia Scale (2006), which are consistent with the original adult questionnaire for alexithymia (TAS-20) in the first stage and Family Assessment Device (FAD), based on McMaster's model in the second stage. Pearson correlation between subscales of total family functioning and alexithymia and emotional intelligence was statistically significant. Results of the multiple regression analysis, together with independent variables entered, simultaneously indicate that as a group, the independent variables significantly contributed to the prediction of emotional intelligence.

[Fataneh Naghavi, Ma'rof Redzuan. **Relationships between Family Functioning, Alexithymia and Emotional Intelligence among Early Adolescents in Tehran-Iran**. Life Science Journal 2012;9(1):396-401].(ISSN:1097-8135). <http://www.lifesciencesite.com>. 58

**Keywords:** Family Functioning, Early Adolescent's Emotional Intelligence, Family Assessment Device, Alexithymia, Children's Alexithymia, Emotional Quotient.

### 1. Introduction

As emotional intelligence is acquisitive and of social origin (Goleman 1995, Mayer and Salovey 1990), parents and children, in their interactions, expose their emotions expression way to one another consciously or unconsciously. The family has the highest effect on the individuals and it can mould their behaviors at any moment. A behavior which is created in relation to other family members is not limited to a normal agreeable behavior. The family can form abnormal behaviors, too (Sanaei, 2000). Considering, alexithymia is not classified as a mental disorder in the [DSM-IV](#). It refers to the difficulty to identify, describe feelings to other people and it is a dimensional personality characteristic that varies in severity from person to person thus, family as a first circumstance can create this kind of characters. In addition, the treatment by parents to their children and how they react to their interests and activities, as well as children treatment to one another, emotion and information exchange among them, emotional protection to one another, and the relationships of the family members' with outsiders may also influence the children's emotional intelligence (Naghavi, 2010).

The family functioning construct is a relatively new concept with little empirical research,

particularly related to the link between seven specific sub-components of the family function (dysfunction) and their emotional intelligence's early adolescent.

There has been a growing interest in the family functioning and emotional functioning of early adolescence (Goodyer, & Herbert, 1998; Walsh, 1993, Patterson, 2002, Ozbaci, 2006) and the factors that influence it (Goleman 1996, Mayer and Salovey, 1990; Carlson, 1999; Palmer et al., 2007; Bar-On, 1997; Martinez-Pons, 1997; Schutte's, 1998) in order to develop more integrated theories of development (McMaster's, 1995; Epstein, Bishop, & Levin, 1960; Goleman, 1995). There are many assumptions about family functioning and emotional intelligence. Ozbaci (2006) has assessed the relationship between and family environment and emotional intelligence EQ. The sample of the study was selected as 274 parents who live in Istanbul including 152 female, 122 male. Data were collected by EQ-NED and "Family Environment Scale" to determine family characteristics and the EQ. The results of the study indicate that there was a relationship between family cooperation and EQ. Manuel (2002) has carried out a study on the effects of parents on emotional intelligence among 109 young people between the ages 11 and 15. Along with emotional intelligence, effects of families on some other dimensions like

responsibilities, social functions and symptoms of depression have also been studied. Upon the assessment carried out by Path analysis technique it has been determined that parent models with methods like encouraging, giving rewards and guiding have crucial effects on matters of emotional intelligence, social activities and symptoms of depression.

A conceptually similar emotional intelligence construct is alexithymia. A comparison of the definitions of emotional intelligence and alexithymia suggests that the two constructs are closely related (Parker *et al.*, 2001). Meanwhile, the emotional intelligence construct emerged from an integration of an array of research findings on how people appraise, communicate and use emotion (Salovey & Mayer, 1989, 1990). Although psychological systems have negatively looked into emotions, the attention given to emotions and feelings can be regarded as the core and basis of psychology and one can therefore look for mental disturbances roots in emotional perturbations like fear, anxiety, depression and alexithymia (Naghavi *et al.*, 2010). Moreover, there is empirical evidence indicating that alexithymia is associated with the difficulties in discriminating among different emotional states (Bagby *et al.*, 1993). In research studies by Salovey and Mayer (1989, 1990), the overlapping emotional intelligence and alexithymia constructs were acknowledges, and the researchers made attempts to empirically evaluate the relationships between the two constructs. One possible explanation for this is that these investigators have yet to introduce a standardized method for assessing emotional intelligence.

It is understood from the previous studies that emotional intelligence is associated with some factors, such as family function and some personality characters like alexithymia. This research studied the relation between family functioning and emotional intelligence so as to develop and expand the concept of emotional intelligence in the family. In other words, the importance of family functioning on alexithymia and emotional intelligence has been found to be very significant. It is expected that this research would identify different family functioning dimensions have influences on early adolescents' emotional intelligence. Although a body of relevant research literature is available, the findings of such research studies which investigated the effects of family functioning on early adolescents' emotional intelligence were derived mainly from western-based samples that are socially and culturally different from the Iranian sample.

## 2. Materials and Methods

The purpose of this study was to examine the relationship between family functioning, alexithymia

and sub-components of the early adolescent's emotional intelligence among Iranian guidance schools students in Tehran, Iran. The schools were chosen based upon their location and programs of study. The population of research involved in this study consisted of all the Iranian students who enrolled in guidance schools of Tehran (234 students, academic year 2010-2011).

The data were collected using (Schutte, 1998) Emotional Intelligence Scale for assessing early adolescence's emotional intelligence and Rieffe's Children's Alexithymia Scale (2006), at the first stage and the Family Assessment Device (FAD) at the second stage.

In addition, the demographic questionnaire was also used to gather relevant background information of the subjects in this research.

The emotional intelligence scales used to assess emotional intelligence, i.e. Schutte's Emotional Intelligence Self-measuring Scale (introduced by Schutte and her colleagues in 1998 and Mayer and Salovey's original emotional intelligence model, 1990), was used to measure emotional intelligence, which includes emotional conception and appraisal, emotion regulation and emotion utilization. This scale includes 33 self-report items. The subject selected his/her degree of agreement or disagreement by any of these sentences in a five-point Likert scale, from strongly disagreed = 1 to strongly agreed = 5. In this study, the reliability for the emotional intelligence test was obtained by using Crombach's alpha,  $\alpha = 0.84$ .

The Rieffe's Children's Alexithymia Scale (2006) Consistent with the original adult questionnaire for alexithymia (TAS-20; Bagby, Parker, & Taylor, 1994), the Rieffe's scale was used to assess alexithymia in children. This scale was introduced by Taylor in 1986, and further revised by Taylor, Bagby, and Parker in 1994. They made the alexithymia 20-question questionnaire by using the factors analysis method. Three current indicators of the questionnaire are: (1) difficulty in identifying feelings, (2) difficulty in describing feelings, and (3) thinking with external orientation. The higher the score on the Rieffe's scale, the higher the level of alexithymia. All the sentences were coded on 3 forms, from not true (a) to true (c). This instrument was developed by Rieffe *et al.* (2006). In this study, the reliability obtained for the alexithymia questionnaire using Cronbach's alpha was  $\alpha = 0.73$ .

Family Assessment Device (FAD); This particular questionnaire was designed to measure family functioning based on McMaster's model. It contains 60 questions specifying six aspects of family functioning: problem-solving, communication, affective responding, affective involvement, control,

and the 7<sup>th</sup> subscale related to the overall family functioning. Every question presents a description of family and the subject chooses his/her agreement or disagreement with a sentence in a four-option scale (strongly agree = 1, agree = 2, disagree = 3, strongly disagree = 4). The FAD test is scored in a way that the score of each family shows its vulnerability degree; lower scores indicate sounder functioning and higher scores on the family functioning questionnaire indicate family's inefficiency. It means that the higher the score, the less healthy is the family functioning. In the current study for the family functioning questionnaire, the reliability obtained was  $\alpha = 0.89$ .

Considering the questions and research hypotheses, the following statistical methods are used to analyze data: after normality test, Correlation techniques enable researchers to describe the relationship between two sets of measures (Pearson  $r$ ). Pearson's Correlation and Regression for describing the relation between variables (e.g., correlation between family functioning and emotional intelligence or correlation between alexithymia and emotional intelligence), were conducted for analyses of this research hypothesizes. The multi regression analysis was used to predict the variables.

### 3. Results and Discussion

#### Description of the participants

The study was among 7150 girls and boys Iranian students. After determining the sample gathering, 4 regions selected random among Tehran's 19 educational regions. Then, among the guidance schools of each region, 2 schools are selected by simple random method: one girls' school and one boys' school. In each school, pupils are selected from grade 3 and grade 2 by simple random method. The sample (234) consisted of the guidance schools pupils (12-15 years old). The respondents (234) for this study were the early adolescence with 116 boys and 118 girls.

The descriptive analysis of early adolescences' family functioning, emotional intelligence, alexithymia scores and its subscales are presented in Table 1, including, mean, standard deviations, highest and lowest scores of the all variables of study area.

The correlation coefficient between the subscales of emotional intelligence and family functioning, except for some cases, was found to be statistically significant,  $\text{sig} = .000$ ,  $p < 0.01$ . The range of Pearson correlation coefficient ( $r$ ) for the subscales of emotional intelligence and family functioning was estimated from  $r = -0.21$  to  $r = -0.89$  ( $p < 0.01$  and  $p < 0.05$ ). also, In this study, the correlation coefficient between the subscales of emotional intelligence and

alexithymia was found to be statistically significant ( $\text{sig} = .000$ ,  $p < 0.01$ ). The range of Pearson correlation coefficient ( $r$ ) between the subscales of emotional intelligence and alexithymia was estimated to be from  $r = -0.23$  to  $r = -0.88$  ( $p < 0.01$  and  $p < 0.05$ ). In addition, the purpose of these correlations is to make sure that multicollinearity is not issue in this study.

As reported above, relationship between pair subscales of emotional intelligence and alexithymia are significantly negative. It means adolescents with category of high factors of alexithymia displayed less factors of emotional intelligence. Moreover, the variables of alexithymia and emotional intelligence had significant negative relationship, which suggested that as alexithymia increased, emotional intelligence also tended to decrease. Difficulty in identifying feelings was related to emotional conception or appraisal. The result of this study was consensus with the findings in Parker et al. (2001) study which suggested that high emotional intelligence might be a protective factor for mental and physical health and low emotional intelligence, related to highly alexithymia individuals. These findings conform to results obtained by Akimoto and Ferkonishi (2003), Ciaruchi et al. (2000), Schutte et al. (1998), and Khosrow Javid (2008). According to Mayer and Salovey (1990), those who get high scores in alexithymia (particularly in thinking with external orientation) are weaker able to identify emotions by facial states and display weak empathy because they cannot understand and assess others' emotions (Ciaruchi et al., 2000). It seems that people struck with alexithymia are very weak in emotional self-consciousness and emotion expression based on emotional intelligence.

In the other word, early adolescents with category of high factors of family functioning displayed more factors of alexithymia. Overall, the variables of family functioning and Alexithymia had significant positive relationship, which suggested that as family functioning increased, alexithymia also tended to increase too, significantly. Dysfunctional family affective responsiveness was related to difficulty in describing feelings. Furthermore, findings of the previous research on family factors related to alexithymia indicated that general family pathology was associated with alexithymia. In particular, difficulty identifying feelings was related to dysfunctional family affective involvement (Lumley et al. 1996). Thus, early adolescent develop specific alexithymia characteristics as a result of family dysfunction in emotional or cognitive domains. This view agrees with theories of the social cognitive theory.

In this research regression analysis was used for studying the relationship between several predictors'

independent variables and dependent variable. The main purpose is to find precisely which independent variables predict the dependent variables. In this linear regression analysis, emotional intelligence was the dependent variable and family functioning and alexithymia were the independent variables. The

independent variables were entered simultaneously into the regression analysis. Table 3, presents the result of the Pearson correlation between emotional intelligence, family functioning and alexithymia.

**Table 1: Mean and Standard Deviation of Family Functioning, Emotional Intelligence, Alexithymia, and Their Factors**

<i>Descriptive indicators Variables</i>	<i>Frequency</i>	<i>M</i>	<i>SD</i>	<i>Up</i>	<i>Low</i>
<b>Family functioning</b>	234	129.25	23.39	158	58
<i>Problem-solving</i>	234	11.52	3.08	86	34
<i>Communication</i>	234	15.47	3.52	190	16
<i>Roles</i>	234	19.85	4.23	64	23
<i>Affective company</i>	234	18.26	3.54	50	12
<i>Affective involvement</i>	234	17.47	4.76	47	19
<i>Behavior control</i>	234	19.68	4.02	35	6
<i>General functioning</i>	234	27.07	6.13	25	5
<b>Emotional intelligence</b>	234	122.36	16.93	32	10
<i>Emotional conception &amp; appraisal</i>	234	35.84	7.96	22	1
<i>Emotion regulation</i>	234	50.27	6.75	27	2
<i>Emotion utilization</i>	234	36.25	5.71	31	3
<b>Alexithymia</b>	234	57.67	23.39	27	5
<i>Difficulty in identifying feelings</i>	234	21.54	6.23	28	2
<i>Difficulty in describing feelings</i>	234	14.96	3.77	30	1
<i>Thinking with external orientation</i>	234	21.17	4.39	48	4

**Table 2: Correlation Coefficients Matrix for Subscales of Emotional Intelligence, Family Functioning and Alexithymia**

<i>Variables</i>	<i>X1</i>	<i>X2</i>	<i>X3</i>	<i>X4</i>	<i>X5</i>	<i>X6</i>	<i>X7</i>	<i>X8</i>	<i>X9</i>	<i>X10</i>	<i>X11</i>	<i>X12</i>	<i>X13</i>
<i>Correlation coefficients</i>													
<i>X1:Emotional conception &amp; appraisal</i>	1												
<i>X2:Emotion regulation</i>	0.326**	1											
<i>X3:Emotion utilization</i>	0.421*	0.382**	1										
<i>X4:Problem-solving</i>	-0.602*	0.664**	-0.701*	1									
<i>X5:Communicatio</i>	-0.563*	-0.201*	-0.410**	0.478*	1								
<i>X6: Roles</i>	-0.578*	-0.0681*	-0.805**	0.431*	0.472*	1							
<i>X7:Affective company</i>	-0.501*	0.261**	-0.821*	-0.221*	0.110**	0.233	1						
<i>X8:Affective involvement</i>	-0.661**	0.097	-0.312*	-0.899*	0.177	0.053*	0.21**	1					
<i>X9:Behavior control</i>	-0.711**	0.005	-0.822**	-0.397*	0.104**	0.19**	0.31*	0.352	1				
<i>X10:General functioning</i>	-0.432**	-0.201*	-0.880**	-0.501*	0.304**	0.22**	0.08*	0.407*	0.053*	1			
<i>X11:Difficulty in identifying feelings</i>	-0.833**	-0.093	-0.671*	-0.782*	0.119**	0.72*	0.09	0.81**	0.779*	0.360**	1		
<i>X12: Difficulty in describing feelings</i>	-0.490**	-0.051*	-0.885*	-0.799*	0.440	0.37**	0.91*	0.23*	0.151*	0.382*	0.732*	1	
<i>X13: Thinking with external orientation</i>	-0.239*	-0.080	-0.814*	-0.597**	0.143*	0.222	0.482*	.495*	0.886*	0.080*	0.251**	0.777*	1

-Dependent Variable: Emotional Intelligence

Note: \* P<0.05. \*\* p<0.005

\* Correlation is significant at the 0.05 level (one tailed)

\*\* Correlation is significant at the 0.01 level (two tailed)

**Table 3: Summary Information of Pearson correlation for Emotional Intelligence, Family Functioning and Alexithymia**

<i>Variables</i>	<i>Family functioning</i>	<i>Emotional intelligence</i>	<i>Alexithymia</i>
<i>Correlation coefficients</i>			
<b>Family functioning</b>	1		
<b>Emotional intelligence</b>		1	
<b>Alexithymia</b>			1

P<.01

### Multiple regression analysis

Result of multiple regression analysis with the independent variables entered simultaneously indicated that the independent variables as a group significantly contributed to the prediction of emotional intelligence. The independent variables were entered into the regression analysis as a group and all two independent variables (family functioning and alexithymia) were presented in the total score obtained on the respective measure. The independent variables predicted 82% of the variance in Emotional Intelligence ( $F=516.239$ ,  $p<.01$ ) table 4, The adjusted R square value suggests the percentage of variance in the dependence variable (Emotional Intelligence) that is likely to be explained by the set of predictors

(family functioning and alexithymia) for the entire population. For this regression analysis the adjusted R square was 0.82. For the entire population, 82% of the variance in Emotional Intelligence is likely to be explained by family functioning and alexithymia.

The R square obtained on this sample is quite significant. Based on Cohen's (1988) guidelines, an R square on 0.26 is considered to be large. In the current sample, the very large R square suggests that the effects are not simply due to a large sample. The same effects would likely have been found even with a much smaller sample size. This indicates that the current study has much practical significance.

**Table 4: Summary Information of ANOVA for Emotional Intelligence Regression on Family Functioning and Alexithymia**

	<i>SS</i>	<i>Df</i>	<i>MS</i>	<i>F</i>	<i>Sig</i>
<i>Regression</i>	14023.93	2	7011.97	516.24	.000
<i>Residual</i>	3137.63	231	13.58	516.24	.000
<i>Total</i>	17161.56	233			

**Table 5: Relative Effects of Family Functioning and Alexithymia to the Prediction of Emotional Intelligence**

	<i>B</i>	<i>SE B</i>	<i>Beta</i>	<i>T</i>	<i>Sig</i>
<i>Constant</i>	293.24	7.15		41.04	.000
<i>Alexithymia</i>	-1.48	0.09	-0.64	-17.15	.000
<i>Family functioning</i>	-0.65	0.07	-0.34	-8.98	.000

### 4. Conclusion

Regarding to finding of this research, early adolescents with category of high factors of family functioning displayed more factors of alexithymia. Overall, the variables of family functioning and Alexithymia had significant positive relationship, which suggested that as family functioning increased, alexithymia also tended to increase too, significantly. Dysfunctional family affective responsiveness was related to difficulty in describing feelings. Furthermore, findings of the previous research on family factors related to alexithymia indicated that general family pathology was associated with alexithymia. In particular, difficulty identifying feelings was related to dysfunctional family affective involvement (Lumley et al. 1996).

Naghavi (2011), demonstrated that early adolescent develop specific alexithymia characteristics as a result of family dysfunction in emotional or cognitive domains in her study. These findings are well agreed with theories of the social cognitive theory. Due to according social cognitive theory early adolescents learn to express, understand, and regulate their emotions in interactions with their family, siblings. Family is strong shapers to early adolescent's behavior (Stover, 2003). In addition, parental emotion affect on early adolescent's emotion and social behaviors by its emotional regulation.

The important point is that, today in the Iran, Iranian families have started to take on roles vastly different from family of previous generations. Moreover, family takes on ever more responsibility for raising their early adolescents than in the generations that preceded them. Subsequently, the modern role of Iranian family would responsibly as several dimensions more now than ever at home with the family particular, with early adolescents and family is as emotional coaches of early adolescent's emotional intelligence and their social behaviors.

### Corresponding Author:

Dr. Ma'rof Redzuan Department of Social and Development Science, Faculty of Human Ecology, University Putra Malaysia, 43400 Serdang, Selangor, Malaysia. Tel: +600389467064  
[marof@putra.upm.edu.my](mailto:marof@putra.upm.edu.my)

### References

- Goleman, D. *Emotional Intelligence: Why It Can Matter More Than IQ*. New York: Bantam, 1995.
- Mayer, P. Salovey a. J. D. *Emotional intelligence. Imagination, Cognition and Personality, 9*, 1990. 185-211.
- Sanaei, B.C.D. *50 Great Philosophers: from Thales to Sartre* (M. R. Mehrabadi, Trans.). Tehran: Ataei Publications, 2000.

4. Naghavi, Fataneh. The relationship between family functioning and alexithymia. Canada International Conferenc on Education(CICE-2010).Canada, 2010.
5. Goodyer , T.I.M. & Herbert, J. Family functioning and parent general health in families of adolescents with major depressive disorder. *Journal of Affective Disorders*, 48, 1998. 1-14.
6. Walsh, F. *Normal family process*. New York: The Guilford Press, 1993.
7. Patterson, J.M. *Promoting Resilience in Families Experiencing Stress*, 2002.
8. Ozbaci, N. Emotional intelligence and family environment. *Sosyal Bilimler Dergisi*, 16,2006.169-175.
9. Manuel, M.P. Parental inducement of emotional intelligence. *Imagination, Cognition, Personality*, 18, 2002. 3-23.
10. Parker, J.D.A. *Emotional Intelligence: Clinical and Therapeutic Implications*. San Francisco: Jossey-Bass Inc, 2001.
11. Salovey, P. & Mayer, J.D. Emotional intelligence. *Imagination, Cognition, and Personality*, 9, 1989/1990. 185-211.
12. Naghavi, Fataneh, R. Ma'rof., and Mariani, M. The relationship between alexithymia and emotional intelligence. *Asian Social Science*, Published by Canadian Center of Science and Education, 2010; (6), 2010. 166-170.
13. Goleman, D. *Emotional Intelligence: Why It Can Matter More Than IQ*. Learning, 24,1996. 49-50.
14. Carlson, G. L. *Family Treatment: Efficient Therapy Guarantee* (S. Navabinejad, Trans.). Tehran: Teachers and Parents Association Publications, 1999.
15. Palmer, C.D. a. C. S. Emotional intelligence and life satisfaction. *Personality and Individual Differences*, 33,2007. 1091-1100.
16. BarOn, R. *Emotional Quotient Inventory Technical Manual*. Toronto: Multi-Health Systems, Inc, 1997.
17. Martinez, P.M. The relation of emotional intelligence with selected areas of personal functioning. *Imagination, Cognition, and Personality*, 17, 1997. 3-13.
18. Schutte, N., Malouff, J.M., Hall, L.E., Haggerty, D.J., Cooper, J.T., Golden, C.J., & Dornheim, L. Developmet and validation of a measure of emotional intelligence. *Personality and Individual Differences*, 25, 1998. 167-177.
19. Carolien Rieffe, P.O. & Terwogt, M.M. An alexithymia questionnaire for children: Factorial and Concurrent Validation results. *Personality and Individual Differences*, 40, 2006. 123-133.
20. Bagby, R. M., Parker, J.D.A., Taylor, G.J., & Acklin, M.W. *Alexithymia and the ability to distinguish different emotional states*. Poster Presentation at the Annual Meeting of the American Psychosomatic Society, Charleston, S.C.,1993, March.
21. McMaster, A. *The Intelligence Advantage: organizing for complexity, Knowledge Based Development*. IOM: Douglas, 1995.
22. Parker, J.D.A., Taylor, G. & Bagby, R.M. The relationship between emotional intelligence and alexithymia. *Personality and Individual Differences* 30, 2001. 107-115.
23. Akimoto M, Fukunishi I. The association of alexithymia and emotional intelligence. *Journal of Psychosomatic Research* 55. 2003, 147-178.
24. Ciarrochi, J.V., Chan, A.Y.C., & Caputi, P. A critical evaluation of the emotional intelligence construct. *Personality and Individual Differences*, 28, 2000. 539-561.
25. Khosravi, M. (2008). *Study of Parent-Child Role in Tehran High school Girls' Individualism Procedure*. Tehran: Tarbiyat Moalem.
26. Lumley, M., Mader, J., Gramzow, A. and Papineau, K. Family factors related to alexithymia characteristics. *Psychosomatic Medicine*, 58, 1996.211-216.
27. Cohen, J. *Statistical Power Analysis for the Behavioral Sciences*. NY: Academic Press, 1977.
28. Naghavi, Fataneh. Family functioning and early adolescens' psychopathology. *World Applied Sciences Journal* 15, 2011.1512-1517.

1/25/2012



## Relationship between nitrogenous pollution of borehole waters and distances separating them from pit latrines and fertilized fields

Basie Vinger<sup>1</sup>, \*Mbhuti Hlophe<sup>2</sup> and Mailoo Selvaratnam<sup>2</sup>.

<sup>1</sup>Department of Chemistry, University of Limpopo (Turloop Campus), Sovenga 0711, Republic of South Africa.

<sup>2</sup>Department of Chemistry, North-West University (Mafikeng Campus), Mmabatho, 2735, Republic of South Africa.

[mbhuti.hlophe@nwu.ac.za](mailto:mbhuti.hlophe@nwu.ac.za)

**Abstract:** The occurrence of the following nitrogenous pollutants, namely ammonium, nitrite and nitrate ions, was investigated in groundwater (borehole) sources of two villages in North West Province of South Africa. The study was carried out for two reasons. The Department of Water Affairs and Forestry (DWAf) in Mmabatho had expressed anxiety over anomalous levels of nitrate ion (which can be reduced to the toxic nitrite ion) in some groundwater sources in the province (and this included some groundwater sources in the two villages). The concentrations of the nitrogenous pollutants were monitored by differential pulse polarography (DPP). This electrochemical method was selected because it is fast, has low detection limits and is virtually free of interferences. The study indicated that the main pollutant in the groundwater sources was nitrate ions whose concentrations were higher than 25 ppm in some borehole waters. This is more than two times higher than the 10 ppm N specification recommended by the South African National Standard (SANS) for drinking water. The study also indicated that the concentrations of ammonium and nitrite ions in the borehole waters studied are not a health risk to the communities. Important sources of groundwater pollution are pit latrines and maize fields treated with nitrogen fertilizers. It was found that groundwaters (borehole water) were polluted with nitrate ions when the distances of the pit latrines and fertilized maize fields were respectively less than 18 m and 13 m from the boreholes. The pollution was more pronounced when the water table was shallow.

[Basie Vinger, Mbhuti Hlophe and Mailoo. Selvaratnam. Relationship between nitrogenous pollution of borehole waters and distances separating them from pit latrines and fertilized fields. Life Science Journal 2012;9(1):402-407]. (ISSN:1097-8135). <http://www.lifesciencesite.com>. 59

**Keywords:** Nitrogenous pollution; methaemoglobinemia; and carcinogenesis; pit latrines; fertilized maize fields; boreholes; differential pulse polarography.

### 1. Introduction

The majority of people in South Africa drink untreated groundwaters and they are mainly from boreholes (Modise and Krieg, 2004). It is important, therefore, to check whether borehole waters are polluted. An important type of pollution is due to  $\text{NO}_3^-$ ,  $\text{NO}_2^-$  and  $\text{NH}_4^+$  ions, which are inorganic ions containing nitrogen. Studies have shown that the concentrations of nitrate ions ( $\text{NO}_3^-$ ) is high in many groundwaters in South Africa (Modise and Krieg, 2004; Fourie and van Ryneveld, 1995; Sililo and Saayman 2001; Tredoux et al, 2000; Bhagwan et al, 2006; Conrad et al, 1999; Tredoux, 2004; Fourie and van Ryneveld, 1994; Xu and Braune, 1995; Terblanche, 1991; Jackson, 1998). and that it is particularly high in a belt running in a north-easterly direction from the Northern Cape through the North West Province to Limpopo Province (Tredoux, 2000).

Nitrate ion is a health risk because it is reduced to the toxic nitrite ion ( $\text{NO}_2^-$ ) by microbiological processes in our stomachs. Nitrite ions reduce the oxygen-carrying capacity of blood and may cause methaemoglobinemia in infants (Girard and Hillaire-Marcel, 1997; Jacks et al, 1999;

Ramaraju et al, 1999; Wakida and Lerner, 2005; Chiroma et al, 2007; Banks et al, 2007; Ohou et al, 2008; Suthar et al, 2009; Hesseling et al, 1991; Lewis et al, 1980) and they can also react with amino compounds, in many media, to form nitrosoamines which are strongly carcinogenic (Girard and Hillaire-Marcel, Ramaraju et al, 1997; Wakida and Lerner, 2005; Suthar et al, 2009).

Nitrogenous pollutants reach groundwater sources by several pathways, the most important of which are seepage of water containing these pollutants from the following sources (Water Quality Management Policies and Strategies in RSA. April, 1991) : decayed vegetation and animal matter; pit latrines; sewage; domestic and farm effluents; fertilizers applied to farm lands. The main purpose of this study was to investigate pollution due to pit latrines and nitrogenous fertilizers. The main purpose of this study was to investigate pollution due to pit latrines and nitrogenous fertilizers and the objectives were to: determine the concentrations of  $\text{NO}_3^-$ ,  $\text{NO}_2^-$  and  $\text{NH}_4^+$  ions in some selected borehole waters; find out whether there is a correlation between these concentrations and the distances separating the boreholes and pollution sources (pit latrines and

fertilized maize fields); make suggestions for preventing pollution of borehole waters.

A pit latrine is easy to construct and maintain. A hole having a depth of about 2 metres is generally dug in the ground over which a seat is placed and this is enclosed in some structure that has a roof and a door (Palmer, 1981). Liquid waste will infiltrate into the surrounding soil and the amount that can be absorbed by the soil will depend mainly on its composition and texture. Nitrogenous pollution due to pit latrines has been studied by many workers (Bhagwan et al, 2006; Conrad et al, 1996; Tredoux, 2004; Fourie and Ryneveld, 1994; Xu et al, 1995; Terblanche, 1991; Jackson, 1998; Girard and Hillaire-Marcel, 1997; Jacks, 1999; Banks et al, 2007; Ohou et al, 2008; Palmer, 1981; Reed, 1994). Their studies show that nitrogenous pollution depends on many factors, some of the more important of which are: number and sizes of pit latrines; distance of pit latrine from boreholes; depth of aquifers; soil and rock composition and their textures around the aquifers.

Two villages (Schoongezicht and Welverdiend) situated in the Ditsobotla District of North West Province were selected for the study. This area was chosen because of information supplied by the Department of Affairs (Mmabatho) that waters in these areas are polluted with nitrate ions. Topography of area is illustrated in Figure 1.

The land slopes very gently to the north-east at a gradient of 1 in 50 metres (Brinn, 1991). Welverdiend is at a lower altitude than Schoongezicht and water flows from Schoongezicht to Welverdiend. The water levels at Schoongezicht and Welverdiend were respectively about 9 metres and 6 metres below ground level. Water samples from nine boreholes were studied. Details of the boreholes relevant to this study are shown in Table 1.

Row 7 in this Table shows the distances separating the pit latrines and maize fields from the boreholes. Rows 2, 3, 4, 5 and 6 give, respectively, information about borehole location, borehole number, equipment with borehole, borehole depths and water level depths. Row 8 gives the number of pit latrines close to each borehole.

## 2. Materials and Methods

### (a) Apparatus

BAS-100B/W Electrochemical Workstation was used to obtain polarograms for the standard solutions and the water samples. Oyster pH meter was used for measuring the pH and temperatures of the water samples collected.

### b) Collection and storage of groundwater samples

Water samples from the nine boreholes were collected once a week for six weeks during the winter season, June/July. Sampling was done in the morning and the water samples were collected in 1 litre polyethylene bottles. The pH and temperature of each water sample was then recorded and 1 millilitre of 10 ppm  $\text{HgCl}_2$  solution (preservative) was added to each sample. Until analysis, the samples were kept in a refrigerator.

### (c) Preparation of standard solutions of $\text{NO}_3^-$ , $\text{NO}_2^-$ and $\text{NH}_4^+$ ions for obtaining calibration curves

Analar potassium nitrate ( $\text{KNO}_3$ ), sodium nitrite ( $\text{NaNO}_2$ ) and ammonium sulphate,  $(\text{NH}_4)_2\text{SO}_4$ , were used respectively to prepare 1 000 ppm N stock solutions of  $\text{NO}_3^-$ ,  $\text{NO}_2^-$  and  $\text{NH}_4^+$  ions. These solutions were then appropriately diluted to prepare the solutions for obtaining calibration curves (concentration range: 2 ppm – 20 ppm).

### (d) Preparation of o-nitrophenol from $\text{NO}_3^-$ ions (Metrohm Application Bulletin No. 70e,1979; Vinger, 1998)

2.0  $\text{cm}^3$  of the  $\text{NO}_3^-$  solution was mixed with 2.0  $\text{cm}^3$  of phenol in a beaker. 8.0  $\text{cm}^3$  of concentrated sulphuric acid was then added slowly while swirling the contents of the beaker, to prepare o-nitrophenol.

### (e) Preparation of diphenyl nitrosoamine from $\text{NO}_2^-$ ions (Barsotti et al, 1982; Vinger, 1998)

3.0  $\text{cm}^3$  of diphenylamine was added to a solution containing 2.0  $\text{cm}^3$  of the  $\text{NO}_2^-$  solution and 10.0  $\text{cm}^3$  of potassium thiocyanate (KCNS). Diphenyl nitrosoamine is then formed.

### (f) Preparation of methyleimine from $\text{NH}_4^+$ ions (McLean, 1978; Vinger, 1998)

To 5.0  $\text{cm}^3$  of the buffer solution of pH 4, 5.0  $\text{cm}^3$  of formaldehyde and 15.0  $\text{cm}^3$  of the  $\text{NH}_4^+$  ion solution were added. The mixture was then heated on a water bath for 5 minutes, to form methyleimine.

### (g) Procedure for obtaining a Differential Pulse Polarogram (DPP)

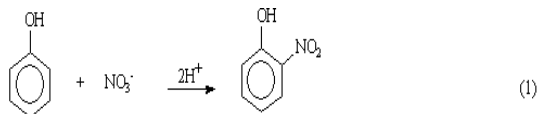
10  $\text{cm}^3$  of the solution (of o-nitrophenol, diphenyl nitrosoamine or methyleimine) was transferred into a polarographic cell. The solution was purged for 5 minutes with high purity nitrogen gas (to remove dissolved oxygen) and its DPP was recorded using appropriate instrument parameters. A typical DPP, for an o-nitrophenol solution (prepared from  $\text{NO}_3^-$ ), is shown in Figure 2.

### (h) Determination of concentrations of $\text{NO}_3^-$ , $\text{NO}_2^-$ and $\text{NH}_4^+$ ions

Differential pulse polarography (Skoog et al, 1992), (DPP), the most sensitive polarographic method, was used for the determination of the concentrations of  $\text{NH}_4^+$ ,  $\text{NO}_3^-$  and  $\text{NO}_2^-$  ions in the water samples collected from the boreholes. For recording the differential pulse polarograms, a BAS-100B/W electrochemical workstation was used. The working electrode (WE) was a dropping mercury electrode (DME) and the counter (AE) and reference electrodes (RE) were respectively a coiled platinum wire and silver /silver chloride.

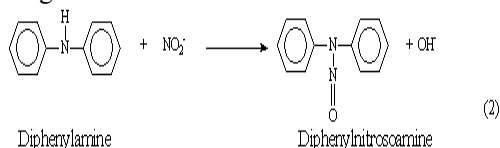
#### Determination of nitrate ions

The concentration of nitrate ion ( $\text{NO}_3^-$ ) was determined by reacting it with phenol in an acidic medium to form ortho-nitrophenol (Metrohm Application Bulletin No. 70e, 1979) and then obtaining a differential pulse polarogram of the solution obtained.



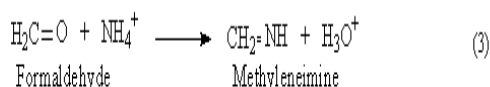
#### Determination of nitrite ions

The concentration of nitrite ion ( $\text{NO}_2^-$ ) was determined by reacting it with diphenylamine at a pH of about 1.5 to form diphenylnitrosoamine (Barsotti et al, 1982) and then obtaining its differential pulse polarogram.



#### Determination of ammonium ions

The concentration of ammonium ions ( $\text{NH}_4^+$ ) was determined by first converting it into methyleneimine ( $\text{CH}_2=\text{NH}$ ) by reacting with excess formaldehyde (HCHO) in an acidic medium (McLean et al, 1978)



and then obtaining a differential pulse polarogram of the methyleneimine solution obtained.

The concentration of each nitrogen species in a water sample was determined from the peak current ( $i_p$ ) by making use of a calibration curve of peak current versus concentration.

#### Determination of concentrations from polarograms

The concentrations of  $\text{NO}_3^-$ ,  $\text{NO}_2^-$  and  $\text{NH}_4^+$  ions in the various water samples were determined from the peak currents ( $i_p$ , see Figure 2) in the appropriate polarograms, by making use of calibration curves that were obtained from plots of peak current ( $i_p$ ) versus concentration of the ion.

The concentrations of  $\text{NO}_3^-$ ,  $\text{NO}_2^-$  and  $\text{NH}_4^+$  ions, obtained from the peak currents of the various borehole water samples over the six weeks sampling period are given in Table 2.

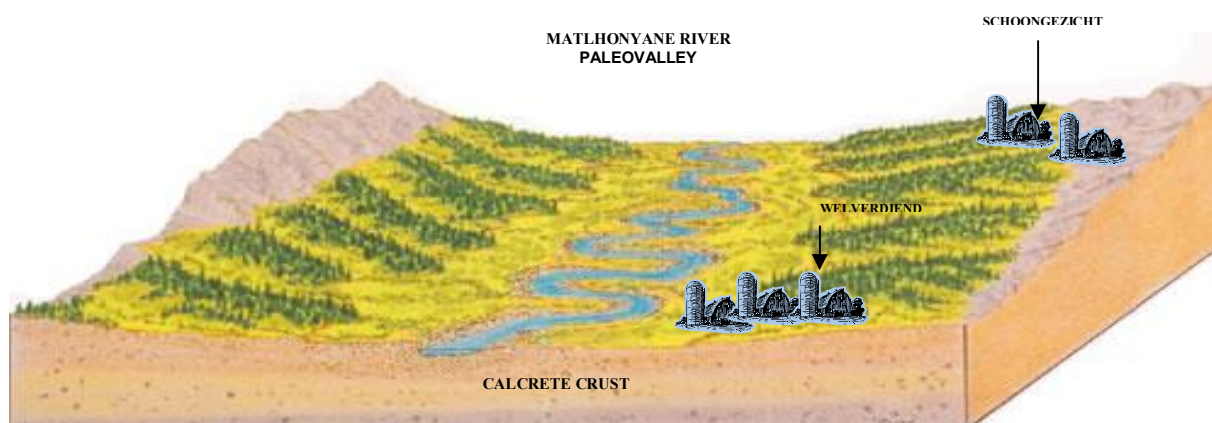
### 3. Results and discussion

The results in Table 2 do not show any trends in the concentrations of the ions from week to week. The average value (for the six weeks) of the concentration of each ion in each borehole was therefore taken to be its best value and this is shown in Table 3.

The ammonium and nitrite ion concentrations (columns 2 and 3 in Table 3) in all the water samples tested are below the South African National Standard (SANS – 241) (South African National Standard, SANS 241, 2005) specification for drinking water, which is less than 2 ppm for  $\text{NH}_4^+$  and 10 ppm for  $\text{NO}_2^-$  ion. These ions should not therefore cause any health problems in the borehole waters tested.

Now consider  $\text{NO}_3^-$  ions. Their concentrations in four of the borehole water samples tested are greater than the SANS specification for drinking water, which is less than 10 ppm  $\text{NO}_3^-$ . In two of these borehole water samples (77265 and Masibi) nitrate concentrations are greater than 20 ppm which are high-risk concentrations (A Guide for the Health Related Assessment of the Quality of Water Supplies, 1996). In two of the borehole water samples (77272 and 77266) the nitrate concentrations are between 10 and 20 ppm and these are in the low-risk range (Reed, 1994).

Table 4 shows the relationship between the nitrate ion concentration ( $c$ ) and the distance ( $d$ ) separating the boreholes and the pollution sources (pit latrines, P.L., and maize fields, M.F.).



**Figure 1:** A diagram showing the topography of the Bethel-Itsoseng area and the positions of the two villages (Schoongezicht and Welverdiend).

**TABLE 1: Selected villages and boreholes sampled**

Place	Schoongezicht					Welverdiend			
	Bontle	Field	Clinic	Field	Masibi	Field	Field	Motswai	Café
B/No	77085	77272	77271	77893	Private	77266	77265	77355	Private
Equipment	Hand pump	Windmill	Hand pump	Windmill	Hand pump	Windmill	Hand pump	Hand pump	Hand pump
Depth (m)	37	76	71	Not known	Not known	Not known	Not known	Not known	Not known
Water level (m)	3	9	9	Not known	Not known	7	6	Not known	Not known
Location	13 m from 2 pit latrines	12 m from maize field	In the field	30 m from maize field	11 m from 4 pit latrines	50 m from 2 pit latrines	10 m from maize field	84m from 5 pit latrines	26 m from 1 and 24 m from 2 pit latrines
No. of pit latrines	2	0	4	0	4	2	0	5	3

B/No = Borehole number  
 Bontle = Bontle Primary School  
 Motswai = Motswaiso Middle School  
 Masibi = Mr Masibi's place  
 Café = Regoikantse café

**TABLE 2: Concentrations in ppm of NH<sub>4</sub><sup>+</sup>, NO<sub>2</sub><sup>-</sup> and NO<sub>3</sub><sup>-</sup> ions in borehole water samples.**

B.N.	Week 1			Week 2			Week 3			Week 4			Week 5			Week 6		
	<sup>c</sup> NH <sub>4</sub> <sup>+</sup>	<sup>c</sup> NO <sub>2</sub> <sup>-</sup>	<sup>c</sup> NO <sub>3</sub> <sup>-</sup>	<sup>c</sup> NH <sub>4</sub> <sup>+</sup>	<sup>c</sup> NO <sub>2</sub> <sup>-</sup>	<sup>c</sup> NO <sub>3</sub> <sup>-</sup>	<sup>c</sup> NH <sub>4</sub> <sup>+</sup>	<sup>c</sup> NO <sub>2</sub> <sup>-</sup>	<sup>c</sup> NO <sub>3</sub> <sup>-</sup>	<sup>c</sup> NH <sub>4</sub> <sup>+</sup>	<sup>c</sup> NO <sub>2</sub> <sup>-</sup>	<sup>c</sup> NO <sub>3</sub> <sup>-</sup>	<sup>c</sup> NH <sub>4</sub> <sup>+</sup>	<sup>c</sup> NO <sub>2</sub> <sup>-</sup>	<sup>c</sup> NO <sub>3</sub> <sup>-</sup>	<sup>c</sup> NH <sub>4</sub> <sup>+</sup>	<sup>c</sup> NO <sub>2</sub> <sup>-</sup>	<sup>c</sup> NO <sub>3</sub> <sup>-</sup>
77893	ND	1.00	3.19	ND	0.62	3.20	0.003	ND	2.44	1.34	ND	6.58	1.89	ND	3.88	0.23	ND	1.41
77265	ND	ND	31.9	1.80	ND	33.6	1.01	ND	18.6	0.39	ND	43.2	2.89	ND	20.8	0.03	ND	25.4
77266	ND	ND	10.0	ND	ND	11.1	ND	ND	6.89	2.10	0.11	9.89	5.37	ND	13.1	ND	ND	11.8
77085	ND	ND	11.2	2.00	ND	11.3	ND	ND	7.13	0.82	0.09	9.53	2.91	ND	9.59	0.16	ND	10.3
77271	1.44	N.D	9.09	3.10	ND	10.2	0.02	ND	6.74	ND	ND	11.1	ND	ND	9.59	0.20	ND	8.19
77355	ND	3.89	2.25	1.50	ND	3.50	ND	ND	3.71	ND	0.10	4.84	ND	ND	6.31	0.44	ND	4.01
77272	-	-	-	0.50	ND	10.4	0.63	ND	8.54	1.56	ND	14.2	2.82	ND	10.8	0.85	ND	12.2
Café	ND	ND	6.49	1.60	ND	7.20	0.50	ND	5.92	1.04	0.35	5.87	ND	ND	10.7	ND	ND	7.30
Masibi	ND	0.94	14.3	8.30	ND	21.6	ND	ND	21.8	ND	ND	34.9	ND	ND	30.2	ND	0.09	36.2

ND = not detected

B.N. = borehole number

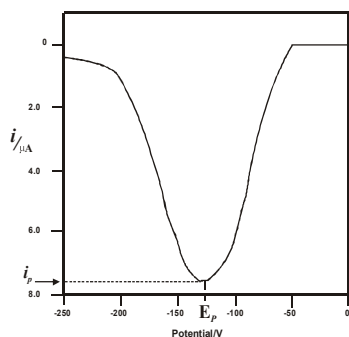
**TABLE 3: Average concentrations in ppm of NH<sub>4</sub><sup>+</sup>, NO<sub>2</sub><sup>-</sup> and NO<sub>3</sub><sup>-</sup> in borehole water samples for all 6 weeks.**

Borehole number	<sup>c</sup> NH <sub>4</sub> <sup>+</sup>	<sup>c</sup> NO <sub>2</sub> <sup>-</sup>	* <sup>c</sup> NO <sub>3</sub> <sup>-</sup>
77893	0.6	0.3	3.5
77265	1.0	0	28.9
77266	1.2	0.02	10.5
77085	1.0	0.02	9.8
77271	0.8	0	9.2
77355	0.3	0.7	4.1
77272	1.3	0	11.2
Café	0.5	0.06	7.2
Masibi	1.4	0.17	26.5

\*The precision of the concentration of the nitrate ion results has been expressed in terms of the standard deviation.

**Table 4: Relationship between concentration of nitrate ions and distance from pollution source.**

Borehole	77265	Masibi	77272	77266	77085	77271	Cafe	77355	77893
<i>c/ppm</i>	29.0	26.5	11.2	10.5	9.8	9.2	7.3	4.1	3.5
<i>d/m</i>	10	11	12	50	13	-	26	84	30
Pollution source	M.F.	P.L. (4)	M.F.	P.L. (2)	P.L. (2)	P.L. (4)	P.L. (3)	P.L. (4)	M.F.

**Figure 2:** A typical differential pulse polarogram (DPP) to determine nitrate ions

The data in Table 4, except for borehole 77266, suggest a correlation between nitrate ion concentration and the distance separating the boreholes from the pollution source. They show that water samples in boreholes that have the highest concentrations of nitrate ions (77265 and Masibi) are at the closest distances to a pollution source, and those that have the lowest concentrations (boreholes 77385 and 77893) are far away from pollution sources.

From this study it appears that effluents from pit latrines and fertilizers applied to maize fields cause nitrate pollution of borehole waters. The nitrate pollution occurs if the pollution source is less than about 12 metres from boreholes.

This results obtained from this study is essentially in agreement with earlier reports by Xu and Braune, (1995); Ohou et al, (2008); Conrad et al, (1999); and Tredoux, (2004).

## 5. Conclusions and recommendations

This study suggests that pollution of borehole waters is likely if the distance separating the boreholes from a pollution source (pit latrines, fertilized maize fields) is less than about 12 metres. The following could be done to prevent or reduce pollution of borehole waters:

(a) Proper construction, operation and maintenance of sanitation systems. There is a need for appropriate legislation, and its enforcement, concerning the

specifications, siting, design, construction and maintenance of pit latrines and septic tanks.

(b) Planting of trees and reeds around boreholes. Nitrogenous pollutants will then be absorbed by the

roots of these trees and reeds.

(c) Controlled application of fertilizers to maize fields.

(d) Education of the people in rural communities as to how pollution of borehole waters can be prevented.

## ACKNOWLEDGEMENTS

We thank the Water Research Commission (WRC) of South Africa for the provision of the research grant for the purchase of equipment and funding for the project as a whole. We thank ESKOM (Tertiary Education Support Programme, TESP) for further financial support. Finally, our gratitude also goes to the Department of Chemistry, North-West University (Mafikeng Campus) for the provision of the laboratory infrastructure.

## \*Corresponding author:

Dr M. Hlophe  
Department of Chemistry  
North-West University, Mafikeng Campus  
Private Bag X2046, Mmabatho, South Africa.  
E-mail: [mbhuti.hlophe@nwu.ac.za](mailto:mbhuti.hlophe@nwu.ac.za)

## REFERENCES

1. Banks D, Karnachuk OV, Parnachev VP, Holden W, Frengstad B. Groundwater contamination from rural pit latrines: Examples from Siberia and Kosova. *Water and Environment Journal*, 2007; 16(2): p. 147 – 152.
2. Barsotti DJ, Pylypin H.M, Harrington GW. The Determination of Nitrate and Nitrite ions by Differential Pulse Polarography. *Anal. Lett.* 1982; 15 (17): p. 1411-1422.
3. Bhagwan JN, Still D, Buckley C, Foxon K. When last did we look down the pits? WISA, 2006.
4. Brinn, C. Cainozoic Deposits of the Eastern Molopo Drainage Basin. A Geological Survey, 19 October, 1991.
5. Chiroma HD, Ayinla GT, Orish OE, Emmanuel OO, Jigam AA, Makun HA, Sani GM, Johnson AO.

- Seasonal nitrate content of stream water, soil and some foodstuffs samples in Abuja Municipal Area of Federal Capital Territory, Nigeria. 2007.
6. Conrad JE, Colvin C, Sililo O, Gorgens A, Weaver J, Reinhardt C. Assessment of the impact of Agricultural Practices on the Quality of Groundwater Resources in South Africa. Water Research Commission 1999; Report no. 641/1/99.
  7. Department of Water Affairs and Forestry, and Department of Health. A Guide for the Health Related Assessment of the Quality of Water Supplies. 1996; First Edition.
  8. Fourie AB, van Ryneveld MB. The fate in the subsurface of contaminants associated with on-site sanitation: A review. *Water SA* 1995; 21(2): p. 101 – 111.
  9. Fourie AB, Ryneveld MB. Environmental impact of on-site sanitation – a literature review with particular application to South Africa. Water Research Commission 1994; Report no. KV57/94, Pretoria.
  10. Girard P, Hillaire-Marcel C. Determining the source of nitrate pollution in the Niger discontinuous aquifers using the natural  $^{15}\text{N}/^{14}\text{N}$  ratios. *Journal of Hydrology*, 1997; 199: p. 239 – 251.
  11. Hesseling PB, Toens PD, Visser H. An epidemiological survey to assess the effect of well-water nitrates on infant health at Rietfontein in the Northern Cape Province of South Africa, 1991. *S.A. Journal of Science* 1991; 87: p. 300-304.
  12. Jacks G, Sefe M, Carling M, Hammar M, Letsamoa P. Tentative nitrogen budget for pit latrines – eastern Botswana. *Environmental Geology*, 1999; 38 (3): p. 199 – 203.
  13. Jackson BM. Are we exaggerating the dangers of groundwater pollution from on-site sanitation systems such as pit latrines? *Borehole Water Journal* 1998; 40: p. 18 – 21.
  14. Lewis WJ, Farr JL, Foster SSD. The pollution hazard to village water supplies in eastern Botswana. *Proc. of the Institute of Civil Engineers* 1980, Part 2; 69: p. 281-293.
  15. McLean JD, Stenger VA, Reim RE, Long MW, Huller TA. Determination of Ammonia and other Nitrogen Compounds by Polarography. *Anal. Chem.* 1978; 50: p. 1309-1314.
  16. Metrohm Application Bulletin No. 70e. Polarographic Determination of Nitrate in Water, Plant and Soil Extracts, Vegetable Juices, Meat and Sausages, Fertilizers, Compost Manure, etc, 1979.
  17. Modise SJ, Krieg HM. Evaluation of nanofiltration for the treatment of rural groundwater for potable water use. Water Research Commission (WRC), 2004, report No. 1230/1/04.
  18. Ohou MA, Mambo V, Yapo BO, Seka MA, Tidou AS, Kamagate B, Houenou PV. Temporal and spatial variations of nitrate levels in traditional water-supply wells in the Area of Buyo, Cote d'Ivoire. *Journal of Applied Sciences*, 2008; 8(18): p. 3096 – 3107.
  19. Palmer I. Nitrates in Groundwater Supply to Villages in Botswana, M.Sc. (Engineering) Thesis, June, 1981.
  20. Ramaraju HK, Venkatachalappa M, Ranganna AG, Sadashivaiah C, Rao, N.M. Hazards due to migration of septic tank leakages in peri-urban settlements. 1999.
  21. Reed R. Why pit latrines fail? Some Environmental Factors. *Waterlines Appropriate Technologies for Water Supply and Sanitation*, 1994; 13 (2): p. 5 – 7.
  22. Sililo OTN, Saayman IC. Groundwater vulnerability to pollution in urban catchments. Report to the Water Research Commission, 2001; WRC Project No. 1008/1/01, ISBN 1 86845 783 4.
  23. Skoog DA, West DM, Holler FJ. *Fundamentals of Analytical Chemistry*, New York: Holt, Rinehart and Winston, Inc. 1992, 6<sup>th</sup> Edition.
  24. South African National Standard, SANS 241 (2005) for Drinking Water.
  25. Suthar S, Bishnoil P, Singh S, Mutiyar PK, Nema AK, Patil NS. Nitrate contamination in groundwater of some rural areas of Rajasthan, India. *Journal of Hazardous Materials* 2009; 171: p. 189 – 199.
  26. Terblanche APS. Health hazards of nitrate in drinking water. *Water SA* 1991; 17: p. 77 – 82.
  27. Tredoux G, Talma AS, Engelbrecht JFP. The increasing nitrate hazard in groundwater in the rural areas. WISA 2000 Biennial Conference, Sun City, South Africa.
  28. Tredoux, G. Nitrate and associated hazard quantification and strategies for protecting rural water supplies. Water Research Commission 2004; Report no. 1058/1/04.
  29. Vinger BH. Nitrogenous pollution of boreholes by pit latrines and fertilized maize fields. M.S.c. dissertation, University of North West, 1998.
  30. Wakida FT, Lerner DN. Non-agricultural sources of groundwater nitrate: A review and case study. *Water Research*, 2005; 39: p. 3 – 16.
  31. Water Quality Management Policies and Strategies in RSA. April, 1991.
  32. Xu Y, Braune E. Minimum distance as an important concept for borehole source protection in South Africa. *Ground Water '95, 1995. Ground Water Recharge and Rural Water Supply*, Midrand.

## The study of the difference between the melamine stone induced hydronephrosis and congenital hydronephrosis in infants: clinical features and their 24-month follow-up

Jian Guo Wen<sup>1,2,\*</sup>, Yan Wang<sup>1,2</sup>, Rui Zhang<sup>1,2</sup>, Lu Xing<sup>1,2</sup>, Zhenzhen Li<sup>1</sup>, Qing Wei Wang<sup>1</sup>, An Feng Lou<sup>1</sup>, Shengjun Zhang<sup>1</sup>, Jens Christian Djurhuus<sup>2</sup>, Jørgen Frøkiær<sup>2</sup>

<sup>1</sup> Pediatric urodynamic Center, Department of Urology, Institute of Clinical Medicine, Department of Neurology, The First Affiliated Hospital of Zhengzhou University, Zhengzhou, Henan, 450000, China

<sup>2</sup> Institute of Clinical Medicine, University of Aarhus, Aarhus C, 8200, Denmark

\* [jgwen@zzu.edu.cn](mailto:jgwen@zzu.edu.cn)

**Abstract:** To study the difference of clinical features in hydronephrosis induced by urinary melamine stone (HNMS) with that due to congenital ureteropelvic junction obstruction (HNUPJO) in infants. Forty six infants (18.5±10.0 months) with HNMS and 85 infants (20.4±9.3 months) with HNUPJO were included. All HNMS and 30 HNUPJO infants with mild pelvic dilation similar to those of HNMS were followed up for 24 months. Renal ultrasonography, renal function and urinalysis were evaluated at admission and follow up. The clinical features of two groups were compared. At admission, unilateral hydronephrosis occurred in 35 (76%) HNMS and 77 (91%) HNUPJO. More bilateral hydronephrosis were found in HNMS than in HNUPJO (24% vs. 9%,  $P < 0.05$ ). HNMS showed more symptomatic and less abdominal mass appeared comparing with those of HNUPJO. Five cases of acute renal failure were observed in HNMS and none in HNUPJO. The degree of hydronephrosis of HNMS was significantly smaller than those of HNUPJO ( $P < 0.05$ ). At 24-month of follow-up hydronephrosis resolved in 93% HNMS whereas remained stable in 80% HNUPJO. While 5 cases with HNUPJO deteriorated and pyeloplasty had to be performed. Only one HNMS infant needs surgical treatment due to the radiolucent stone has changed to radio-opaque stone, which induced significant ureteral obstruction. Significant difference of clinical feature existed between HNMS and HNUPJO. HNMS appears to be relatively benign. Non-operative management with close follow-up is a reliable and efficacious method for these HNMS infants.

[Jian Guo Wen, Yan Wang, Rui Zhang, Lu Xing, Zhenzhen Li, Qing Wei Wang, An Feng Lou, Shengjun Zhang, Jens Christian Djurhuus, Jørgen Frøkiær. **The study of the difference between the melamine stone induced hydronephrosis and congenital hydronephrosis in infants: clinical features and their 24-month follow-up.** Life Science Journal. 2012;9(1):408-412] (ISSN:1097-8135). <http://www.lifesciencesite.com>. 60

**Keywords:** Melamine; Hydronephrosis; Urolithiasis; Congenital

### 1. Introduction

Pediatric hydronephrosis is a common disorder encountered by physicians in their daily practice. Nowadays, fetal hydronephrosis is more frequently detected due to popular used antenatal ultrasonography<sup>[1,2]</sup>. It is well known that one of the most common causes of congenital hydronephrosis is ureteropelvic junction obstruction (UPJO) which has been previously characterized in the literature<sup>[3]</sup>.

In 2008, the outbreaks of melamine related urinary stone (MRUS) occurred in China<sup>[4]</sup> and thereafter, the ultrasound examination become the routine tool to evaluate the renal morphology as well as finding the urinary stone, the number of hydronephrosis in infants increased dramatically<sup>[5]</sup>. Actually, hydronephrosis is one of the main complications in infants with MRUS, approximately reached 1/3 of cases<sup>[6]</sup>. Clinically, hydronephrosis induced by urinary melamine stone (HNMS) need to be distinguished with the hydronephrosis due to congenital ureteropelvic junction obstruction (HNUPJO) considering the different treatment and follow up strategy. However, the differential

diagnosis is not always easy, especially in cases with mild degree of hydronephrosis and that induced by a small or occult MRUS.

Although early diagnosis of patients with hydronephrosis is not difficult due to the advances in ultrasonography during the last two decades, disagreement exists over the different diagnostic tests to define obstruction accurately or predict which kidney will benefit from surgical intervention. Furthermore, the indications for and timing of surgery or initial non-operative approach for severe hydronephrosis are still debated. Currently, no data are available regarding the different clinical features of HNMS from those of HNUPJO at admission and that for 2 years follow up. During the outbreaks of melamine related urinary stone at 3 year ago, more than 3000 infants and young children with a history of exposure to melamine contained milk powder came to our hospital for medical evaluation. According to the diagnostic criteria for MRUS established by World Health Organization (WHO)<sup>[7]</sup>, 46 children suffered from HNMS.

The purposes of present study were to summarize the different clinical characteristics of HNMS from those of HNUPJO either at admission and the 24-months follow up.

## 2. Material and Methods

### Patients

The present study included 46 infants (18.5±10.0 months old, 34 boys and 12 girls) who suffered from HNMS and were treated in the First Affiliated Hospital of Zhengzhou University in China in 2008.

MRUS was diagnosed according to the diagnostic criteria established by the WHO [7] and we have reported previously [8]. In brief, key diagnostic criteria include the history of feeding melamine-contaminated infant formula; having one or more clinical manifestations such as unexplained crying and/or vomiting; macroscopic or microscopic hematuria (urinary red blood cell morphology shows normal morphology of red blood cells), acute obstructive renal failure: oliguria or anuria; parathyroid hormone test (normal); ultrasound B exam indicated urinary system stone imaging.

The hydronephrosis diagnosis is mainly depending on the ultrasonography, which was graded according to the Society for Fetal Urology (SFU) guidelines [9]. Evidence of consumption of melamine-contaminated infant formula, including powdered milk bags with batch number matched by data promulgated by Chinese authorities, was required at the time of diagnosis. Analysis of six discharged stones with a combined liquid-phase chromatography/mass spectrum method (Esquire-LC MS analyzer, produced by Bruker Co.) revealed that the main components of stone were uric acid and melamine. All cases in prenatal ultrasonography screening did not show urologic congenital anomalies.

Eighty five age- and gender-matched infants (20.4±9.3 months old, 68 boys and 17 girls) with prenatally diagnosed HNUPJO and confirmed after birth served as controls and these children did not have any history of consumption of toxic milk powder.

Radiographic, functional, and laboratory data of urinary system were recorded. The study was approved by the Medical Ethics Committee of Hospital and parents.

### Treatment at admission

All cases with HNMS received conservative, short-term hospital treatment, including cessation of melamine-contaminated infant formula consumption immediately, intravenous hydration, urine alkalinization and anti-spasmodic drugs after diagnosis. Five severe acute renal failure cases

underwent hemodialysis. After discharging patients were asked to maintain oral medication with tablets of sodium bicarbonate and antispasmodics. The choice of conservative or surgical management to HNUPJO patients was based on the results of ultrasonography and IVU. Surgical intervention was necessarily performed if there was evidence of obstructive injury, defined as a reduction in renal function, persistent anuria and/or ultrasonographic progression of hydronephrosis

### Follow-up

Pyeloplasty was the initial therapeutic approach in 55 HNUPJO (65%) and conservative follow-up was undertaken in the remaining 30 HNUPJO (35%) and all HNMS for 24 months after discharging from the hospital. The follow up data collection form is consisting of two sections. The first section recorded background information such as age, sex, body height and weight, feeding mode (mixed/artificial), oral calcium supplementation and history of exposure to melamine-tainted milk formula with brand name and duration of exposure. Mixed feeding was defined as breastfeeding and artificial feeding. The second section contained detailed clinical data, including symptoms, urinary tract ultrasound, urinalysis, routine blood testing, and hepatic and renal function. Plain abdominal radiography was performed for differential diagnosis, MRUS were radiolucent.

### Statistical analysis

Statistical analyses were performed with SPSS, version 10.0 for Windows. All values were expressed as mean ±SD. *t* test, chi-square were used to evaluate the differences. A *P* value of less than 0.05 was considered to indicate statistical significance.

## 3. Results

### Clinical features at admission

There was no significant difference in male-to-female ratio of HNMS vs. HNUPJO (2.8:1 vs. 4.0:1); however, male preponderance in each group is obvious.

Hydronephrosis was unilateral in 35 (76%) HNMS and 77 (91%) HNUPJO patients. More bilateral hydronephrosis were found in HNMS than in HNUPJO (24%, 11/46 vs. 9%, 8/85, *P* < 0.05) (Table 1). HNMS show more symptomatic (abdominal mass, dysuria, renal colic (unexplained crying, oliguria or anuria, macroscopic or microscopic haematuria and hypertension) than those of HNUPJO (67% vs. 41%, *p* < 0.05) (Table 2). Five cases of acute renal failure were observed in HNMS and none in HNUPJO. More than 2 kinds of



symptoms were found simultaneously in 4 of HNMS and in 11 of HNUPJO.

According to the Society for Fetal Urology (SFU) guidelines hydronephrosis graduation, there were 27 HNMS cases and 30 HNUPJO of a mild degree (SFU grade 0, 1), 19 HNMS cases and 44 HNUPJO cases of a moderate degree (SFU grade 2, 3) and 0 HNMS cases and 11 HNUPJO of a severe degree (SFU grade 4). Mean degree of hydronephrosis of HNMS was significantly lighter than HNUPJO ( $p < 0.05$ ) (Table 1).

There was no significant difference of the BUN and Scr between in HNMS and HNUPJO ( $p > 0.05$ ) (Table 3). The PH value of urine was significantly lower in HNMS children compared with HNUPJO ( $p < 0.05$ ), whereas the SUA was significantly higher in HNMS children compared with HNUPJO ( $p < 0.05$ ) (Table 3).

### Treatment and Follow-up

Conservative short-term treatments were used in all HNMS patients immediately after diagnosis. Hemodialysis was performed in 5 HNMS with severe renal failure, and all cases gradually recovered after 1 to 4 times of hemodialysis

treatments. Extracorporeal shock wave lithotripsy (ESWL) was performed in 1 HNMS cases. Primary pyeloplasty was performed in 55 cases with HNUPJO, whereas follow up was carried out in the remaining 30 cases HNUPJO, in which the degree of hydronephrosis is similar to those of HNMS at discharging. During the follow up, 5 HNUPJO patients underwent pyeloplasty due to progressive hydronephrosis and/or reduction in renal function.

At 24-month of follow-up, no mortality was observed, and 98% (45/46) HNMS and 83% (25/30) HNUPJO showed asymptomatic (Table 2). Ultrasonogram follow-up showed that hydronephrosis decreased rapidly during the first 6 months and then more gradually with time. Hydronephrosis resolved spontaneously in 43(93%) HNMS and in none of HNUPJO, remained stable in 2(4%) HNMS and 24(80%) HNUPJO (Table 4). The dilation degree of hydronephrosis decreased significantly in HNMS compared to those of HNUPJO (6.5%, 3/46 vs. 97%, 29/30,  $P < 0.05$ ). The renal function of all the patients were recovered to normal, and the urinary output of whom returned to normal levels.

**Table 1. Site location and Hydronephrosis graduation at admission and 24-month follow-up**

	HNMS		HNUPJO	
	Initial (46 pts.)	Follow-up (46 pts.)	Initial (85 pts.)	Follow-up (30 pts.)
Left Hydronephrosis	27	3	59	22
Right Hydronephrosis	8	0	18	6
Bilateral Hydronephrosis	11	0	8	2
<b>Hydronephrosis graduation</b>				
Mild	27	3	30	19
Moderate	19	0	44	6
Severe	0	0	11	5

**Table 2. Clinical presentation at admission and 24-month follow-up**

	HNMS		HNUPJO	
	Initial (46 pts.)	Follow-up (46 pts.)	Initial (85 pts.)	Follow-up (30 pts.)
Symptomatic	31 (67%)	1 (2%)	35 (41%)	5 (17%)
Asymptomatic	15 (33%)	45(98%)	50 (59%)	25 (83%)

**Table 3. laboratory data at admission and 24-month follow-up**

	HNMS		HNUPJO	
	Initial (46 pts.)	Follow-up (46 pts.)	Initial (85 pts.)	Follow-up (30 pts.)
PH value of urine	5.6±0.6	5.9±0.6	5.9±0.5	6.0±0.5
BUN (mmol/L)	6.2±4.8	5.0±1.8	5.5±4.0	4.8±1.5
SUA (umol/L)	452±304	338±182	312±119	307±107
Scr (umol/L)	108±72	90±22	94±48	84±28

**Table 4. Response at 24-month follow-up**

	HNMS (46 pts.)	HNUPJO (30 pts.)
Resolve	43	0
Improve	1	1
Stable	2	24
Worsen	0	5

#### 4. Discussions

It is well known that most of HNUPJO cases can be identified and diagnosed in the perinatal period with prenatal ultrasonography screening and treated before renal function is reduced<sup>[10]</sup>. However, hydronephrosis caused by urolithiasis, especially in infants and young children is rare. Since the scandal of melamine-contaminated infant formula in 2008, many infants come to hospital for ultrasound examination even with no history of exposure of melamine containment milk powder just due to their parents worried them suffering from the MRUS. Consequently, many of infants was occasionally found exist renal pelvic dilatation during their ultrasound screening. Many HNUPJO case showed a similar degree of hydronephrosis to HNMS.

How to distinguish of them and what different clinical feature of them during the treatment and follow up is unclear. It is well known both hydronephrosis has different etiology and physiology, as well as the treatment method is also not same. Therefore, to compare their clinical features and follow up their development or cure course is valuable for clinical practice.

As previously demonstrated, there was male preponderance in the children with HNUPJO<sup>[11,12]</sup>. In present study, a male-to-female ratio of 2.8:1 from children who suffered HNMS was found. This is in agreement with the ratio reported in a study assessing the influence of gender on the development of pediatric renal stones<sup>[13]</sup>. Similar to HNUPJO, the hormonal and urinary saturation effects on hydronephrosis formation might be the major influence factors and further studies are required.

Our data show that HNMS showed more symptomatic and less abdominal mass comparing with those of HNUPJO, and degree of hydronephrosis of HNMS was significantly smaller than HNUPJO,

suggesting that the different etiology and physiology exist between them. Five cases of acute renal failure were observed in HNMS and none in HNUPJO. The renal failure may result from both intrarenal crystal-associated obstruction and an elevation in renal pressure that reduces renal blood flow and glomerular filtration rather than a systemic toxic effect<sup>[14]</sup>.

At admission, mean degree of hydronephrosis of HNMS was significantly smaller than HNUPJO, whereas, at 24-month follow-up, the dilation degree of hydronephrosis decreased significantly in HNMS compared to those of HNUPJO indicating that infants with HNMS can be managed nonoperatively safely. The finding confirmed that most of these hydronephrotic kidneys of HNMS will recovery with the disappeared of MRUS after conservative treatment..

Treatment options for prenatally diagnosed HNUPJO include conservative and surgical management, with the aim of preserving renal function and preventing complications such as pain or infection<sup>[15]</sup>. Present study show 17% of HNUPJO may need surgical treatment due to deterioration of kidney function. While 2% HNMS infants may need surgical treatment.

In conclusion, significant difference of clinical feature existed between HNMS and HNUPJO. HNMS appears to be relatively benign. Non-operative management with close follow-up is a reliable and efficacious method for these HNMS infants. Recently, melamine contained food has been reported in media again in China. It has been predicted that this will be a long term risk for human food<sup>[16]</sup>. Therefore, to continue our researches on the melamine related kidney stone is necessary.

#### Acknowledgements:

We would like to show our thankfulness to Professor Jochen Mau for the guidance of statistical method.

**Funding:**

Scientific and Technological Project of Henan Provincial Health Bureau (No.2011020037)  
Special Research Fund for the Doctoral Program of Colleges of Ministry of Education (No.20114101120010)

**Corresponding Author:**

Jian Guo Wen, Prof., Ph.D.  
Pediatric Urodynamic Center and Department of Urology  
The First Affiliated Hospital of Zhengzhou University  
No.1, Jian She Dong Rd, Zhengzhou 450052, China.  
Tel: +86 13939068686  
E-mail: [jgwen@zzu.edu.cn](mailto:jgwen@zzu.edu.cn)

**References**

- Helin I, Persson PH. Prenatal diagnosis of urinary tract abnormalities by ultrasound. *Pediatrics*. 1986, 78(5):879-83.
- Shi Y, Pedersen M, Li C, Wen JG, Thomsen K, Stødkilde-Jørgensen H, Jørgensen TM, Knepper MA, Nielsen S, Djurhuus JC, Frøkiaer J. Early release of neonatal ureteral obstruction preserves renal function. *Am J Physiol Renal Physiol*. 2004, 286(6):F1087-99.
- Tripp BM, Homsy YL. Neonatal hydronephrosis—the controversy and the management. *Pediatr Nephrol*. 1995, 9(4):503-9.
- Panfeng S, Hong C, Zhongjin Y, Wei Z, Wenhui L, Baoguang S, Junsheng B, Liingjun Z, Zizhen H. Management of pediatric urolithiasis induced by melamine-contaminated powdered formula (report of 619 cases). *Urology*. 2011, 78(2):411-6.
- Chan EY, Griffiths SM, Chan CW. Public-health risks of melamine in milk products. *Lancet*. 2008; 372:1444-5.
- Wen JG, Chang QL, Lou AF, Li ZZ, Lu S, Wang Y, Wang YL, Hu JH, Mao SP, Zhang Y, Xue R, Ren C, Xing L, Zhang GX, Zhang S, Djurhuus JC, Frøkiaer J. Melamine-Related Urinary Stones in 195 Infants and Young Children: Clinical Features within 2 Years of Follow-Up. *Urol Int*. 2011
- <http://www.who.int/foodsafety/en/>.
- Wen JG, Li ZZ, Zhang H, Wang Y, Zhang RF, Yang L, Chen Y, Wang JX, Zhang SJ. Melamine related bilateral renal calculi in 50 children: single center experience in clinical diagnosis and treatment. *J Urol*. 2010, 183(4):1533-7.
- Fernbach SK, Maizels M, Conway JJ. Ultrasound grading of hydronephrosis: introduction to the system used by the Society for Fetal Urology. *Pediatr Radiol*. 1993, 23(6):478-80.
- Onen A, Jayanthi VR, Koff SA. Long-term followup of prenatally detected severe bilateral newborn hydronephrosis initially managed nonoperatively. *J Urol*. 2002 Sep; 168(3):1118-20.
- Karnak I, Woo LL, Shah SN, et al. Prenatally detected ureteropelvic junction obstruction: clinical features and associated urologic abnormalities. *Pediatr Surg Int*. 2008, 24(4):395-402.
- Karnak I, Woo LL, Shah SN, Sirajuddin A, Ross JH. Results of a practical protocol for management of prenatally detected hydronephrosis due to ureteropelvic junction obstruction. *Pediatr Surg Int*. 2009, 25(1):61-7.
- Coward RJ, Peters CJ, Duffy PG, Corry D, Kellett MJ, Choong S, van't Hoff WG. Epidemiology of paediatric renal stone disease in the UK. *Arch Dis Child*. 2003, 88(11):962-5.
- González J, Puschner B, Pérez V, Ferreras MC, Delgado L, Muñoz M, Pérez C, Reyes LE, Velasco J, Fernández V, García-Marín JF. Nephrotoxicosis in Iberian piglets subsequent to exposure to melamine and derivatives in Spain between 2003 and 2006. *J Vet Diagn Invest*. 2009, 21(4):558-63.
- Kinn AC. Ureteropelvic junction obstruction: long-term followup of adults with and without surgical treatment. *J Urol*. 2000, 164(3 Pt 1):652-6.
- Ingelfinger JR. Melamine and the global implications of food contamination. *N Engl J Med*. 2008, 359(26):2745-8.

12/2/2012

## The Expression and Regulation of GSK-3 $\beta$ , CDK-5 and PP2A in Differentiated Neural Stem Cells of Rats

ZHAO Qing-xia<sup>1,3</sup>, XU Yan<sup>2,3</sup>, YAN Wen-hai<sup>2,3</sup>, HAN Xue-fei<sup>3</sup>, XING Ying<sup>2,3</sup>

1. The Nursing College; 2. The Basic Medical College; 3. The Stem Cells Research Center  
Zhengzhou University, Zhengzhou, Henan 450052, China  
[zzuzhaoqingxia@126.com](mailto:zzuzhaoqingxia@126.com); [xingy@zzu.edu.cn](mailto:xingy@zzu.edu.cn)

**【Abstract】 Objective:** To explore the expression of GSK-3 $\beta$ , CDK-5 and PP2A and the regulation of them by A $\beta$ <sub>25-35</sub> and ginsenoside Rb1 after NSCs are transformed into neurons. **Methods** Neural stem cells of the third passage were induced towards neurons; the expressions of GSK-3 $\beta$  (pTyr279, 216), PP2A and the regulation of them by A $\beta$ <sub>25-35</sub> and ginsenoside Rb1 were tested by the immunofluorescence cytochemical staining after NSCs had been induced for one week; The expressions of GSK-3 $\beta$ , CDK-5, PP2A and the regulation of them by A $\beta$ <sub>25-35</sub> and ginsenoside Rb1 were detected with RT-PCR assays. **Results:** Immunofluorescence cytochemistry showed that neural cells differentiated from NSCs can express GSK-3 $\beta$  (pTyr279, 216) and PP2A. A $\beta$ <sub>25-35</sub> can enhance the expression of GSK-3 $\beta$  (pTyr279, 216), meanwhile it also inhibited the expression of PP2A. Moreover ginsenoside Rb1 can alleviate the affect of A $\beta$ <sub>25-35</sub>. RT-PCR results showed that neural stem cells differentiated from NSCs can express GSK-3 $\beta$ , CDK-5, PP2A. The expression of GSK-3 $\beta$  and CDK-5 rose up and the expression of PP2A weakened when they were treated by A $\beta$ <sub>25-35</sub>. However, the effect of A $\beta$ <sub>25-35</sub> was restrained when they were pretreated by ginsenoside Rb1. **Conclusions** NSCs which were cultured and induced in vitro can express GSK-3 $\beta$ , CDK-5 and PP2A; Additionally A $\beta$ <sub>25-35</sub> and ginsenoside Rb1 can regulate the expressions of GSK-3 $\beta$ , CDK-5 and PP2A. Our results suggest that cells which differentiated from neural stem cells in vitro have protein phosphorylation regulation system of normal cells.

[ZHAO Qing-xia, XU Yan, YAN Wen-hai, HAN Xue-fei, XING Ying. **The Expression and Regulation of GSK-3 $\beta$ , CDK-5 and PP2A in Differentiated Neural Stem Cells of Rats.** Life Science Journal. 2012;9(1):413-418] (ISSN:1097-8135). <http://www.lifesciencesite.com>. 61

**Key words:** neural stem cells; GSK-3 $\beta$ ; CDK-5; PP2A; ginsenoside Rb1; A $\beta$ <sub>25-35</sub>

### Introduction

Neural stem cells (NSCs) are cells that have self-renewal ability and multidifferentiation potential. NSCs are transformed into neurons as its immature forms changed to mature forms, which is coincident with the change of the tau protein's location and expression. Tau protein is an important microtubule-associated protein, and localizes primarily in the axon of neurons. Its major role is to promote the formation and increase the stability of microtubules, therefore it plays an important part in maintenance of the morphology and function of cells. The normal tau protein is a phosphoprotein, and it can not only influence the formation of microtubules when it is hyperphosphorylated, but also can cause various kinds of depositions to localize in the neurons, which will cause damage of the neurons and diseases of the nervous system<sup>[1]</sup>.

Tau protein's phosphorylation is regulated by the relative activity of protein kinases (which catalyze hyperphosphorylation) and protein phosphatases (which catalyze dephosphorylation)<sup>[2-3]</sup>. Glycogen synthase kinase-3 $\beta$  (GSK-3 $\beta$ ) and cyclin-dependent kinase-5 (CDK-5) belong to Ser/Thr kinase, which can promote tau protein hyperphosphorylation in vivo and vitro and play a very important role in the regulation of tau phosphorylation<sup>[1]</sup>. The decreasing activity of

protein phosphatases, especially the activity of protein phosphatase-2A (PP2A), also plays a key part in the regulation of tau phosphorylation<sup>[4-5]</sup>

It has been proved that the mature neurons in the brain can express GSK-3 $\beta$ , CDK-5 and PP2A. A $\beta$ <sub>25-35</sub> and ginsenoside Rb1 can also regulate the expression of GSK-3 $\beta$ <sup>[6]</sup>, CDK-5<sup>[7]</sup> and PP2A. However, there is still no evidence of the neurons which are differentiated from NSCs. Thus, in this study we intend to investigate the expression of GSK-3 $\beta$ , CDK-5, PP2A after NSCs are transformed into neurons and the regulation by A $\beta$ <sub>25-35</sub> and ginsenoside Rb1

### 1. Materials and methods

#### 1.1 Main reagents

A $\beta$ <sub>25-35</sub> (sigma); GSK-3 $\beta$  (pTyr279, 216) antibody (sigma); ginsenoside Rb1 (Chinese Medicine Identification Institute); Rabbit Anti-PP2A antibody (Beijing Zhongshan); DMEM/F12 culture medium (GIBCO); Fetal bovine serum (Hangzhou Chinese Holly Bioengineering Material Research Institute); gelose (Sigma); Marker (TaKaRa Biotechnology); AMV First Strand cDNA Synthesis Kit and PCR Kit (Shanghai Bioengineering Company).

## 1.2 Primer design and synthesis

RT-PCR primer was designed by corresponding software: primer of GSK-3 $\beta$  (Forward: 5' AACACCAACAAGGGAGCAAA 3'; Reverse: 5' GAGCGTGAGGAGGGATAA GG3'), primer of CDK-5 (Forward: 5' ATGGGGAAGGCACCTACGG 3'; Reverse: 5' TCCAGGTCACCATTGCAGCT 3'), primer of PP2A (Forward: 5' AGGTGGGAG AGTCGTCATCT3'; Reverse: 5' GTGGTAGGTATGGGCGTTGG 3') and primer of  $\beta$ -actin for intra-contrast (Forward: 5' GAGCTGCGTGTGGCCC CT AG3'; Reverse: 5' AGTTTCATGGATGCCACAGG3'). All primers were synthesized by Shanghai Bioengineering Company.

Table 1. Sequences of primers

Gene	GeneBankNo.	Primer sequence	Product size
<i>CDK-5</i>	NM—080885	Forward:5'ATTGGGGAAGGCACCTACGG 3' Reverse:5'TCCAGGTCACCATTGCAGCT 3'	249bp
<i>GSK-3<math>\beta</math></i>	NM—032080	Forward:5'AACACCAACAAGGGAGCAAA 3' Reverse:5'GAGCGTGAGGAGGGATAAAGG 3'	326bp
<i>PP2A</i>	M83297	Forward:5'AGGTGGGAGAGTCGTCATCT 3' Reverse:5'GTGGTAGGTATGGGCGTTGG 3'	455bp
<i><math>\beta</math>-actin</i>	AY039651	Forward:5'GAGCTGCGTGTGGCCCCTGAG3' Reverse:5'AGTTTCATGGATGCCACAGG3'	554bp

## 1.3 Source of animals

The newly born 24h old SD rats were afforded by Animal Center of Zhengzhou University.

## 1.4 Isolation, culture and differentiation of NSCs

NSCs of 24h old SD rats were isolated from the dentate gyrus of the hippocampus and cultured with DMEM/F12 culture medium containing 2%B27, bFGF(20 ng/ml) and EGF (20 ng/ml) at 37°C and 5% CO<sub>2</sub>. The cultured cells were replaced with fresh medium every three days. NSCs began to accumulate and formed neurospheres after one week. We treated NSCs to the next passage by centrifuging the cell's suspension for 5min (1000 rpm). The third passage NSCs were induced into neurons by adding 10% fetal bovine serum and removing mitogens. Undifferentiated neural stem cells, neurons and astrocytes were identified separately with Nestin, NSE and GFAP antibodies by using immunocytochemistry.

## 1.5 The experimental groups

The cells were divided into 3 experimental groups after NSCs had been induced for one week.

- (1) The control group: the cells were cultured for another 36h without additional treatment.
- (2) A $\beta_{25-35}$  treatment group: the cells were cultured for another 24h and added A $\beta_{25-35}$  (20  $\mu$ mol/L) for 12h.
- (3) Ginsenoside Rb1 pre-treatment group: the cells were pre-treated with ginsenoside Rb1 (10  $\mu$ mol/L) for 24h and added A $\beta_{25-35}$  (20  $\mu$ mol/L) for 12h. After total 36h, each group of cells were collected.

## 1.6 Immunofluorescence cytochemistry

Each group of cells were collected from 6-well plates. The operational procedure according to the

instruction of reagent kit. The morphological changes of cells were observed under fluorescence microscope.

## 1.7 RT-PCR

Abstraction of RNA and synthesis of cDNA were processed according to the instruction of reagent kit. Amplification by PCR was carried on after synthesis of cDNA : Put the following materials into Ependoff tubes in turn: 2mmol/L dNTP 2  $\mu$ l, Taq enzyme (5U/  $\mu$ l) 1  $\mu$ l, cDNA 5  $\mu$ l, specific primer 1,2 each of 0.5  $\mu$ l,  $\beta$ -actin 0.5  $\mu$ l, 10 $\times$ PCR buffer 3  $\mu$ l, ddH<sub>2</sub>O 17  $\mu$ l. Conditions of amplification for PCR: 94°C for 3min, 94°C for 45s, 55°C for 45s, 72°C for 1min, 35 cycles later, extending at 72°C for 7min. 5  $\mu$ l amplification product mixed with buffer solution was put into 1.8% gelose gel which contained EB, after electrophoresing by voltage 5-10V/cm for 50minutes, the results were observed by gel scan imaging system.

## 1.8 Statistics analysis

Results expression by  $\bar{X} \pm S$ , analysis data by ANOVA. Comparison between groups by LSD,  $p < 0.05$  is significant.

## 2. Results

### 2.1 Isolation, *ex vivo* culture and differentiation of NSCs

Freshly isolated single NSCs from the dentate gyrus of newborn rats hippocampus were small, round and contained much opaque particles. After 3 passages, the neurospheres grew significantly bigger than before and the particles mostly disappeared. The specific markers of the NSCs(Nestin) were expressed on primary culture and the differentiated cells. After 3

days induction, most floating neurospheres began to adhere to the bottom of the bottle and grew outwards like in the shape of a thorn. After 7 days induction, most cells of the neurospheres grew outwards and

formed axons which were interlaced with each other. Immunocytochemistry found that the differentiated cells showed the specific markers of neurons (NSE) and astrocytes (GFAP).

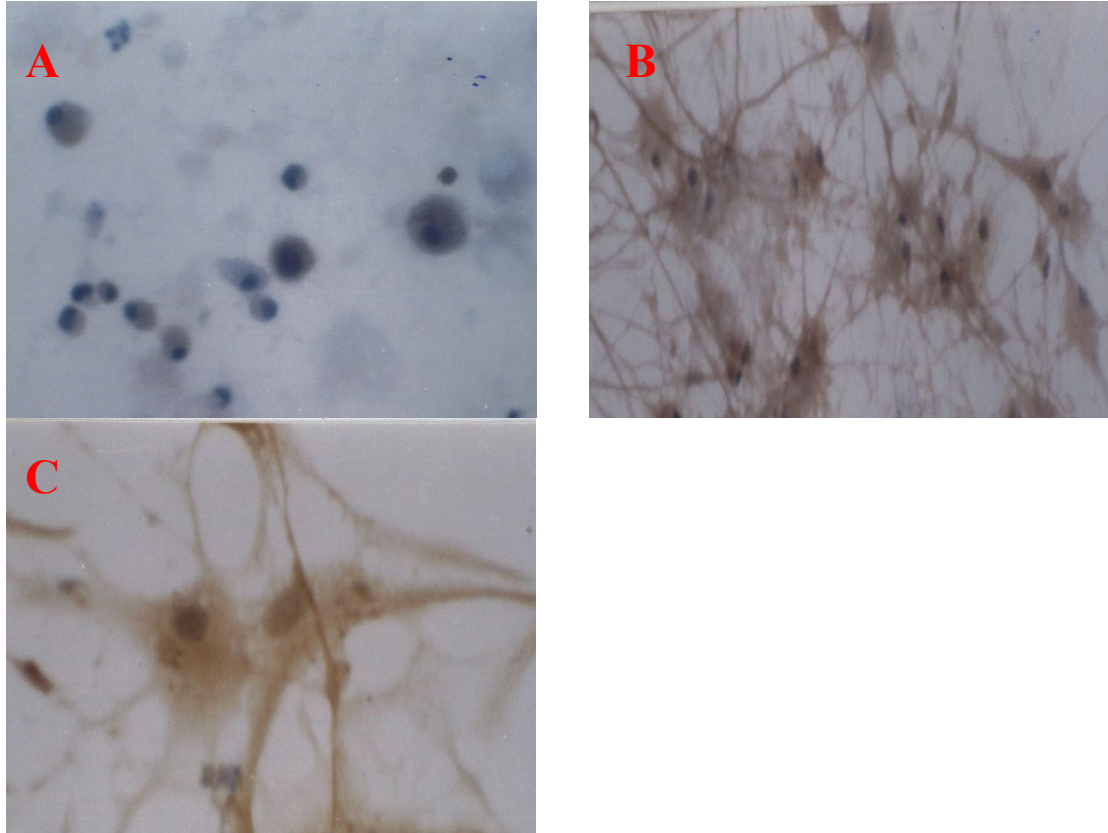


Figure 1. Immunocytochemistry results of NSCs and the cells differentiated form NSCs

A: NSCs have expression of Nestin ( $\times 100$ )

B: The cells differentiated form NSCs have expression of NSE ( $\times 100$ )

C: The cells differentiated form NSCs have expression of GFAP ( $\times 200$ )

## 2.2 Immunofluorescence cytochemistry

Compared with control group, the expressions of PP2A were all reduced in the  $A\beta_{25-35}$  and the ginsenoside Rb1 treatment groups by immunofluorescence cytochemistry assays ,especially in the  $A\beta_{25-35}$  group (Figure 2 A, B, C). However, the expressions of GSK-3 $\beta$  (pTyr279,216) in the  $A\beta_{25-35}$  and the ginsenoside Rb1 treatment groups were all increased compare with which in the control group, especially in the  $A\beta_{25-35}$  group (Figure 2 D, E, F).

## 2.3 Results of gene expression of GSK-3 $\beta$ 、 CDK-5 and PP2A

The cells of the control group expressed GSK-3 $\beta$ 、 CDK-5 and PP2A. The expressions of GSK-3 $\beta$  and CDK-5 in the  $A\beta_{25-35}$  and the ginsenoside Rb1 groups were more than those in the control group. Moreover, the expressions of GSK-3 $\beta$  and CDK-5 were the most in the  $A\beta_{25-35}$  treatment group. The difference was considered significantly ( $p < 0.01$ ); However, the expression of PP2A was lower in the  $A\beta_{25-35}$  and the ginsenoside Rb1 treatment groups than the control group, the expression of PP2A were the lowest in the  $A\beta_{25-35}$  group. The difference was considered significantly ( $p < 0.01$ ).

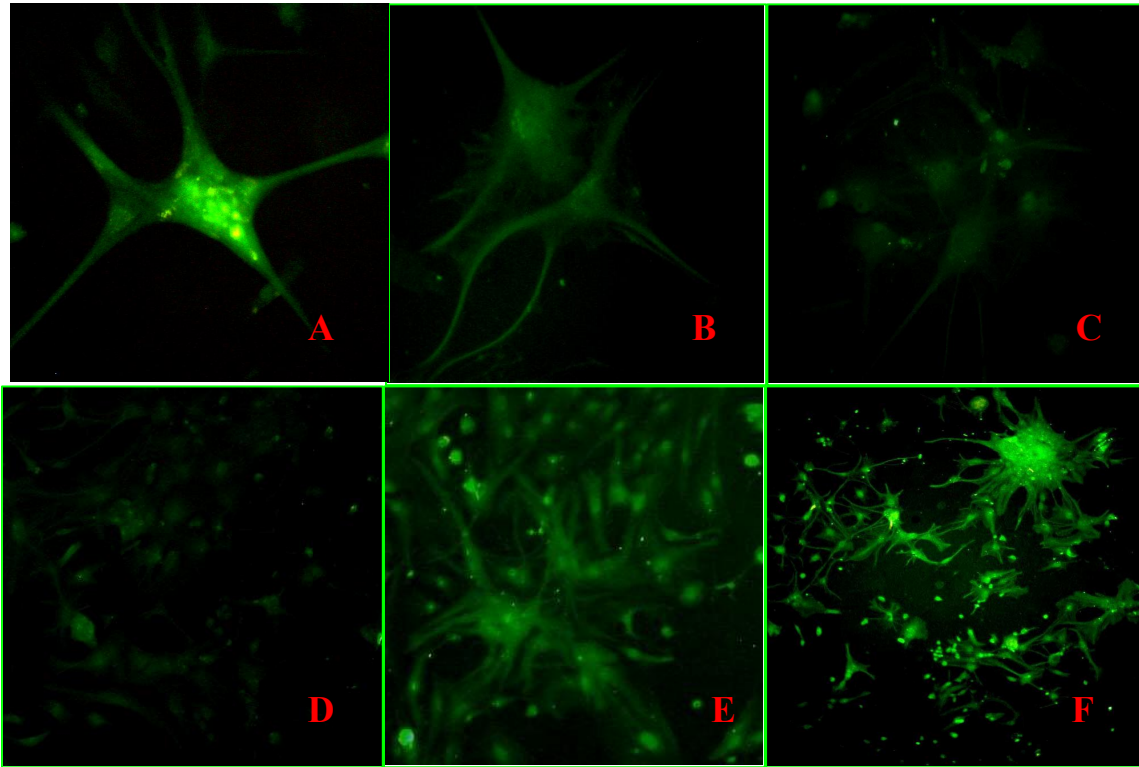


Figure 2. Immunofluorescence cytochemical staining after NSCs had been induced for one week.  
 A, B, C: The cells were stained with GSK-3β (pTry279,216) (×100)  
 D, E, F: The cells were stained with PP2A (×400)  
 A and D: Control group; B and E: Ginsenoside Rb1 group; C and F: Aβ<sub>25-35</sub> group

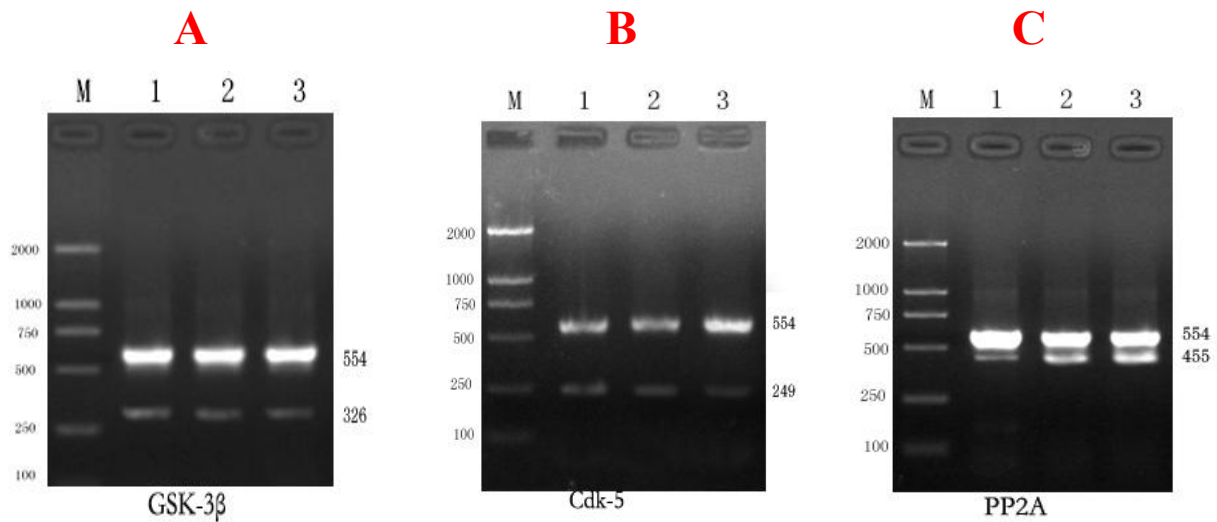


Figure 3. Expression of mRNA after NSCs had been differentiated for one week.  
 A: Expression of GSK-3β; B: Expression of CDK-5; C: Expression of PP2A .  
 M: Marker; 1: Aβ<sub>25-35</sub> group; 2: Ginsenoside Rb1 group; 3: Control group

**Table 2. The expression of GSK-3 $\beta$ /CDK-5/PP2A mRNA after NSCs had been differentiated for one week ( $\bar{X} \pm S$ , n=5)**

group	GSK-3 $\beta$	CDK-5	PP2A
Control	0.074 $\pm$ 0.011	0.084 $\pm$ 0.011	0.714 $\pm$ 0.087
A $\beta_{25-35}$	0.246 $\pm$ 0.011	0.324 $\pm$ 0.011	0.116 $\pm$ 0.011
Ginsenoside Rb1	0.128 $\pm$ 0.008	0.208 $\pm$ 0.008	0.408 $\pm$ 0.072

The difference of compare with each other is significant,  $p < 0.01$ .

### 3. Discussion

Since a long time ago it has been argued that the functional status of the cells differentiated from neural stem cells (NSCs) in rats. Our laboratory has already proved that the neural cells differentiated from NSCs in rats have been found  $K^+$  current by using patch clamp technique (PCT). But it is various to identify the function of neural cells. In this investigation, the neural cells which were differentiated from NSCs in rats expressed GSK-3 $\beta$ , CDK-5 and PP2A by using immunofluorescence cytochemistry and RT-PCR, that is, these neural cells had regulation system of tau protein phosphorylation as same as the mature neural cells in rat's brain. So this experiment identified function of the neural cells which were differentiated from NSCs in another way.

Neuropathologically, Alzheimer's disease (AD) is now defined by the accumulation of two types of insoluble fibrous material--extracellular amyloid protein in the form of senile plaques and intracellular neurofibrillary lesions (NFL) which were made by abnormal and hyperphosphorylated tau protein. In addition to the neurofibrillary tangles (NFTs)<sup>[8]</sup>. The NFL consists neuropil threads and dystrophic neurites which were associated with senile plaques. Although AD and its main brain histopathology, that is, senile plaques and neurofibrillary tangles (NFTs), were described a century ago, The discoveries of the major protein components of senile plaques as amyloid  $\beta$ -peptide and of NFTs as abnormally hyperphosphorylated tau in the 1980s initiated a new era of AD research. Recent studies demonstrate that it is the abnormal hyperphosphorylation that makes tau protein lose its normal function to stimulate microtubule assembly, gain toxic activity, and aggregate into NFTs<sup>[9]</sup>, upregulation of tau phosphorylation could lead to neurofibrillary degeneration<sup>[10]</sup>.

To understand the mechanism leading to abnormal tau hyperphosphorylation in AD, protein kinases and phosphatases which regulate tau phosphorylation level must be identified firstly.

The kinases that most likely play a role in tau phosphorylation in the brain include glycogen synthase kinase-3 $\beta$  (GSK-3 $\beta$ ), cyclin-dependent kinase 5 (CDK-5)<sup>[11]</sup>. The activity of GSK-3 $\beta$  is regulated by Ser and tyrosine phosphorylation. Tyr279, 216

phosphorylation may increase the activity of GSK-3 $\beta$ , however, Ser 9 phosphorylation will down-regulate the activity of GSK-3 $\beta$ <sup>[12-13]</sup>. Our results showed that in A $\beta_{25-35}$  treatment group the expression of GSK-3 $\beta$  mRNA and CDK-5 mRNA, GSK-3 $\beta$  (pTyr279, 216) all raised up, but in GinsenosideRb1 pre-treatment group they were restrained. This result is coincidence with that of in AD brain GSK-3 $\beta$  showed tendency of up-regulation..

Among protein phosphatases, PP2A has been shown to be the major tau phosphatase in the brain<sup>[14-17]</sup>. It has been reported the okadaic acid-induced inhibition of PP2A activity and prevents tau hyperphosphorylation in hippocampal slice cultures from adult rats<sup>[18]</sup>. Our results also showed in A $\beta_{25-35}$  treatment group the expression of PP2A mRNA cut down, but in Ginsenoside Rb1 pre-treatment group it was up-regulation.

These results may due to the following factors: A $\beta_{25-35}$  might activate the activity of GSK-3 $\beta$ , CDK-5 and inhibit the activity of PP2A, which could result in the expression of GSK-3 $\beta$  mRNA and CDK-5 mRNA raise up and the expression of PP2A mRNA cut down in A $\beta_{25-35}$  treatment group. However ginsenosideRb1 might activate the activity of PP2A and inhibit the activity of GSK-3 $\beta$  and CDK-5, which would lead to the expression of PP2A mRNA up-regulated and the expression of GSK-3 $\beta$  mRNA and CDK-5 mRNA down-regulated. in GinsenosideRb1 pre-treatment group. In conclusion, A $\beta_{25-35}$  and GinsenosideRb1 could regulate the expression of GSK-3 $\beta$ , CDK-5 and PP2A in the cells differentiated from NSCs..

Inhibition of dysregulation of protein phosphorylation/dephosphorylation is a promising target to treat AD. Further investigation of new compounds that could inhibit abnormal hyperphosphorylation of tau will likely provide new treatments for AD.

### Project Support

Henan Province Research Project Grant No. 04244100851; Henan Natural Science Grant No. 0611043000.

### Correspondent to:

ZHAO Qing-xia  
The Stem Cells Research Center



Zhengzhou University  
Zhengzhou, Henan 450052, China  
Phone: 01186-139-3853-9808  
Fax: 01186-371-6665-8377  
E-mail: [zzuzhaoqingxia@126.com](mailto:zzuzhaoqingxia@126.com)

XING Ying  
The Stem Cells Research Center  
Essential Medical College  
Zhengzhou University  
Zhengzhou, Henan 450052, China  
Phone: 0371-66658377  
Fax: 0371-66658377  
E-mail: [yingy@zzu.edu.cn](mailto:yingy@zzu.edu.cn)

### References

- Bhaswati Bandyopadhyay, Li Guibin, Yin Haishan et al. Tau Aggregation and Toxicity in a Cell Culture Model of Tauopathy. *Biol. Chem*, 2007, 282(22):16454-16464.
- Kelley B J, Petersen RC. Alzheimer's disease and mild cognitive impairment. *Neurol Clin*, 2007, 25(3): 577—609.
- Wang JZ, Liu F. Microtubule-associated protein tau in development, degeneration and protection of neurons. *Progress in Neurobiology*, 2008, 85(2):148-175.
- Zhang CE, Tian Q, Wei W, et al. Homocysteine induces tau phosphorylation by inactivating protein phosphatase 2A in rat hippocampus. *Neurobiol Aging*. 2008, 29(11): 1654-1665.
- Liu R, Wang JZ. Protein phosphatase 2A in Alzheimer's disease. *Pathophysiology*. 2009, 16(4):273-277.
- 曾育琦, 陈小春, 朱元贵等. 人参皂苷 Rb1 抑制  $\beta$  淀粉样蛋白 25~35 诱导的皮层神经元 tau 蛋白过度磷酸化. *药学学报*, 2005, 40 (3): 225-30
- 黄天文, 陈小春, 张静等. P25/cdk5 可能参与人参皂苷 Rb1 减轻  $A\beta$ 25~35 诱导的 tau 蛋白过度磷酸化. *中国药理学通报*, 2006, 22 (6): 688-93
- Iqbal K, Liu F, Gong CX, et al. Mechanisms of tau-induced neurodegeneration. *Acta Neuropathol*. 2009, 118(1):53-69.
- Alonso Adel C, Mederlyova A, Novak M, et al. Promotion of hyperphosphorylation by frontotemporal dementia tau mutations. *The Journal of Biological Chemistry*. 2004; 279(33):34873–34881.
- Gong, Liu, Grundke-Iqbal, et al. Impaired brain glucose metabolism leads to Alzheimer neurofibrillary degeneration through a decrease in tau O-GlcNAcylation. *Journal of Alzheimer's Disease*. 2006, 9(1):1-12.
- Cruz J C, Tseng H C, Goldman J A, et al. Aberrant Cdk5 activation by p25 triggers pathological events leading to neurodegeneration and neurofibrillary tangles. *Neuron*, 2003, 40(3):471-483
- Bhat RV, Shanley J, Correll MP, et al. Regulation and localization of tyrosine216 phosphorylation of glycogen synthase kinase-3 beta in cellular and animal models of neuronal degeneration. *Proc Natl Acad Sci USA*, 2000, 97 (20): 11074-11079.
- Stambolic V, Woodgett JR. Mitogen inactivation of glycogen synthase kinase-3 beta in intact cells via serine 9 phosphorylation. *Biochem J*, 1994, 303 (pt 3): 701-704.
- Gong C-X, Lidsky T, Wegiel J, et al. Phosphorylation of microtubule-associated protein tau is regulated by protein phosphatase 2A in mammalian brain. Implications for neurofibrillary degeneration in Alzheimer's disease. *The Journal of Biological Chemistry*. 2000;275(8):5535–5544.
- Ling Z, Liu F, Iqbal K, et al. Decrease of protein phosphatase 2A and its association with accumulation and hyperphosphorylation of tau in Down syndrome. *J Alzheimers Dis*. 2008, 13(3):295-302.
- Bennecib M, Gong C-X, Grundke-Iqbal I, et al. Role of protein phosphatase-2A and -1 in the regulation of GSK-3, cdk5 and cdc2 and the phosphorylation of tau in rat forebrain. *FEBS Letters*. 2000, 485(1):87–93.
- Kins S, Cramer A, Evans DR, et al. Reduced protein phosphatase 2A activity induces hyperphosphorylation and altered compartmentalization of tau in transgenic mice. *The Journal of Biological Chemistry*. 2001;276(41):38193–38200.
- Li L, Sengupta A, Haque N, et al. Memantine inhibits and reverses the Alzheimer type abnormal hyperphosphorylation of tau and associated neurodegeneration. *FEBS Lett*. 2004; 566(1–3):261–269.

11/20/2010

**Effect of Afla-Toxins B1 on Endocrine Status in Cat fish (*Clarius lazera*)**<sup>1</sup>Mona S. Zaki and <sup>2</sup>Olfat Fawzy<sup>1</sup>Department of Hydrobiology, National Research Center Dokki, Cairo, Egypt<sup>2</sup>Department of Biochemistry, National Research Center Dokki, Cairo, Egypt  
dr\_mona\_zaki@yahoo.co.uk

**Abstract:** The influence of dietary aflatoxins on body weight, immunity, and hormonal profile was studied in catfish. The results revealed that, administration of aflatoxins, and aflatoxins plus fax-A-toxin 0.1% in diet for 4 months decrease body weight, IgM, Insulin, Thyroxine however there were elevation in cortisol hormone level. Afla-toxins may induce an immunosuppressive effect on humoral immune response of tilapia Nilotica in which was suggested by reduction of immunoglobulin

[Mona S. Zaki and Olfat Fawzy. **Effect of Afla-Toxins B1 on Endocrine Status In *clriaus lazera***. Life Science Journal 2012; 9(1):419-422] (ISSN: 1097-8135). <http://www.lifesciencesite.com>. 62

**Key words:** Afla-Toxins; Endocrine; Cat fish; tilapia Nilotica; mmunosuppressive.

**Introduction**

IgM, is the most important immune factor to neutralize bacteria and render them more susceptible to phagocytosis (Ingram, 1980). It is well known that in mammals immunoglobulin production is closely related to endocrine status (Berezi, 1989) for example thyroid hormone enhance the production of immunoglobulins (Chen 1980). Cortisol intensify, suppress immunoglobulins production (Pottinger 1985). In teolosts cortisol level markedly increased following stressor exposure and elevated cortisol level results in a significant increase susceptibility to infectious. diseases (Pickering and Pottinger, 1985). The purpose of administration of fax-A-toxin particularly with Aflatoxin to know the effect of fax-A-toxin on Aflatoxin in fish. Many studies concerned the effects of cortisol on IgM production (Anderson et al. (1982).. However there is no previous reports on the effect of. Aflatoxins on serum IgM and endocrine status. Many authors observed the effect of Afla toxins on liverdamage. The liver enzymes are changed with observation of malignant tumours (Ostrawski, 1984; and Evmgton et al. 1994).

The present work was under taken to study the effect of *afla* toxins on endocrine status and immunoglobulin M of tilapia fish, this fish was selected because their wide availability edibility in Egypt and their important ecological role m the River Nile .

**2. Material and Methods**

One hundred and twenty Tilapia Niloticus were used in the present study. Their live body weight averaged of 37.5 gram. The fish were healthy and clinically free from external and internal parasites. They were maintained *in* tanks containing well aireated water at atmospheric temperature for two weeks before the xperiments began. Fish were

randomly distributed into four groups; each of 30 fish and 2 control groups, the first group fed Aflatoxin-free ration and used as negative control (C) while the second group (AFC) was fed of Aflatoxins contaminated corn (50 ug toxin/kg ration) and used as positive control. The third group fed aflatoxin- free ration with 0.01% fax-A-toxin. The fourth group fed aflatoxin contaminated corn (50 ug toxin/kg ration) with 0.1% Fax-A-toxin for four months daily. Sources of Aflatoxin is contaminated corn 50 lag toxin/kg ration.

The fish were fed by hand twice daily and feed consumption in all groups was recorded daily. Also the mortality rate and body weight of fish due to Afla-toxins were recorded (Table 1).

**Ration:**

Ration used during trials contained 16.3% crude protein, 2.5% crude fat and 14% crude fibre, the digestible energy was 26% cal/kg. The diet contained feed additives which included minerals, vitamins and amino acids. Body weight measured every month for four month. Sources of Afla toxins present in corn (50 p.g toxin/kg ration).

**Samples:**

Serum samples were collected 4 times at one month interval and Sera were frozen at -20 for later analysis. Serum cortisol, IgM, T4, and insulin were determined using kits.

**1 - IgM determination:**

The serum IgM was measured according to Fuda et al (1991).

**1-a. Preparation of antisera:**

Antisera for Tilapia was prepared by immunizing rabbits as described by Hara (1976).

**Catfish IgM antibody:**

The procedure for labeling antibody fragment with enzyme was performed according to the method of Nagae et al (1993).

**EIISA assay procedure:**

Double antibody sandwich Elisa according to the method of Matsubara et al. (1985) and Nsgae (1993) was used for determination of IgM.

Cortisol was estimated using radio immunoassay technique according to the method of Pickering and Potinger (1983) and Wedmyer (1970).

Serum thyroxine was estimated using radioimmunoassay (RIA) using coat (A) count provide by diagnostic product corporation Los Angeles U.S.A. (Deftoff 1979).

Insulin was determined by RIA according to the method described by Sundly (1991).

**Statistical analysis:**

The difference between the groups were calculated according to Snedecor and Cochran (1967) by t-test

**3. Results**

As shown in Table (1-3) and there is a decrease in body weight in aflatoxins and aflatoxins plus fax-A-toxin 0.1% if compared with control groups.

Table (2) showed the influence of aflatoxins and aflatoxins plus fax-A-toxin on IgM. Highly significant decrease of IgM levels was detected in treated groups with afla toxin and fax-A-toxin 0.1%.

Table (3) showed the serum hormonal changes in infected fish treated with Afla Toxin & Fax-A-Toxin. The results revealed decrease level of insulin, and thyroxine while a highly significant elevation of cortisol level was observed.

**Table (1) Effect of aflatoxin on body weight of cat fish**

Group	1 Month	2 Month	3 Month	4 Month
Aflatoxin	41.8	36.1	31.7	31.1
	38.0	34.2	34.0	28.3
	34.1	30.4	30.5	31.5
Aflatoxin + 0.1 Fax A toxin	43.0	40.3	41.2	41.5
	42.5	30.1	37.4	45.5
	35.5	41.2	31.2	32.6
Control	45.2	43.4	46.7	42.5
	46.0	41.1	41.4	51.6
	36.2	41.5	46.6	46.6
0.1% Fax a toxin	43.6	48.0	41.0	41.2
	44.1	41.4	47.8	44.1
	36.7	47.4	51.8	52.7

AF= Aflatoxin 50 µg/Kg c number of fish each group=30 body weight 1 gm

**Table (2): Effect of aflatoxin in 1gm µg/ml in cat fish (clarious lazera)**

	1 Month	2 Month	3 Month	4 Month
Control	2.86± 0.73	2.45± 0.30	2.54± 0.50	2.00± 0.80
Aflatoxin	1.58*± 1.40	0.94*± 0.36	0.98**± 0.50	0.94**± 0.72
Control + Fax A Toxin	1.54± 0.20	2.60± 0.14	2.68± 1.08	2.30± 1.40
A.F + Fax A Toxin	2.05*± 0.54	2.16*± 0.73	1.95**± 0.27	1.76**± 0.30

AF -> Aflatoxin 50 µg/Kg c number of fish each group=30

**Table (3): Effect of Aflatoxins on Hormonal profile in cat fish**

	Insulin µg/dl				Thyroxine				Cortisol µg/dl			
	1M	2M	3M	4M	1M	2M	3M	4M	1M	2M	3M	4M
Control	13.6 ± 0.31	10.5 ± 2.24	11.00 ± 2.62	13.08 ± 1.70	0.0882 ± 0.05	0.0854 ± 0.077	0.967 ± 0.027	0.950 ± 0.014	0.888 ± 0.16	0.887 ± 0.21	0.921 ± 0.34	0.954 ± 0.73
Aflatoxin	13.2* ± 0.16	12.01* ± 1.20	14.00 ± 1.27	11.08*	0.0640* ± 0.0330	0.0730* ± 0.022	0.0721* ± 0.039	0.0718* ± 0.0549	1.11** ± 0.30	1.42 0.043	1.70** ± 0.027	1.75 ± 0.038
Control + Fax A Toxin	14.1 ± 0.12	13.50 ± 0.52	13.80 ± 0.23	13.72 ± 0.72	0.0942 ± 0.072	0.0988 ± 0.440	0.0943 ± 0.24	0.0849 0.074	0.988 0.33	0.942 ± 0.10	0.980 ± 0.50	0.962 ± 0.67
A.F. Fa A Toxin 0.1	13.00* ± 0.23	13** ± 0.27	12.00* ± 0.20	13.54* ± 0.21	0.0821* 0.069	0.0698* 0.023	0.0764* 0.0023	0.0804** 0.064	1.35* 0.83	1.26* 0.74	1.24* ± 0.86	1.18 ± 0.34

\* P<0.01

A.F -> Aflatoxin \*\* P<0.05

M -> Month

#### 4. Discussion

IgM level was determined to find out information about fish immune system, which was previously investigated in different species by many authors as Matsubara et al. (1985) and Fuda et al. (1991).

In this work the purified IgM revealed a single precipitation in this work reacted against specific polyvalent antiserum to catfish IgM a similar result was obtained by Bagee et al., (1993). They found that chum salmon (IgM) was detected by specific anti (IgM) antibodies.

While the lower limit was 5 mg/ml reported, by Fuda (1991) there is a significant decrease in IgM level in fish with aflatoxins, if compared with control groups. Anderson et al. (1982) found a relation between cortisol and (IgM) as when cortisol increased (IgM) decrease.

The significant increase of cortisol level in intoxication with Afla to. groups could be attributed to stress factors and the intoxication have examine response of fish to stress factors e.g. crowding, continous handling, infection John et al., 1994, Barton et al., 1980, Strange, 1978 and Wedemger, 1970, reported that the elevation of cortisol with aflatoxins and Fax A 0.1% toxin may attributed to intoxication, and continous handling of fish. These observations emphasizes the extreme care needed during design and *analysis* of experiments, involving the (HPI) axis of teleost fish due to extremely sensitive HPI axis. Similar results were reported by pickering and Pottinger (1983).

Serum thyroxine (T<sub>4</sub>) concentrations in the serum of Tilapia species decreased in the intoxicated groups. It has been shown that intoxication, and chronic stress rin a marked long lasting depression of serum T<sub>4</sub> levels in Tilapia fish (Osborn et al 1978) and Milne and Leatherland, (1980). The response of thyroid gland of telosts fish needs further investigated with particular attention to possible relationship between the H.P.I. axis and pituitary thyroid axis. Milne and Leatherland. (1980), Osborn et al. (1978) and Mooreoud et al. (1977) using histological approach concluded that cortisol reduced thyroidal activity in sock eye salmon. The significant decrease of insulin values may be attributed to aflatoxin which may somehow reduce the metabolic activities in the aflatoxin intoxicated fishes. The decrease in body weight was observed, while detectable agrees with Ostrowski<sup>(1)</sup> (1984), Hilton et al. (1987) and Sundly et al. (1991) as they observed a detectable decrease in body weight of duck infected with aflatoxin.

The aim of administration of Fax-A-Toxin particularly with Aflatoxin to know if Fax-A-Toxin eliminate Afla-toxins in the body of fish. In the present study Fax A Toxin not affect Afla-toxins as

the results indicated that IgM, and endocrine status still not corrected or not return to the normal status in Tilapia fish.

In conclusions aflatoxin reduce of the humoral immune response as detected by decrease of IgM level, body weight and cortisol elevation. Suppress IgM, Thyroxine (T<sub>4</sub>) hormone and insulin levels. Fax-A-toxin has no significant effects on aflatoxins.

#### Corresponding author

Mona S. Zaki

Department of Hydrobiology, National Research

Center Dokki, Cairo, Egypt

[dr\\_mona\\_zaki@yahoo.co.uk](mailto:dr_mona_zaki@yahoo.co.uk)

#### References

1. Abdel-Wahhab, M.A. Abdel-Galil, M.M., Hassan, A.M., Hassan, N.H., Nada, S.A., Saeed, A., El-Sayed, M.M. (2007): "Zizyphus Spina-Christi extract protects against aflatoxin B1-initiated hepatic carcinogenicity" Afr. J. Trad. CAM 4 (3): 248-256.
2. Anderson, D.P.; Roberson, B.S. and Dixon, O. W (1982): Immunosuppression induced by corticosteroid or an alkylating agent in Rainbow trout. Dev, comp. Immunol. Suppl. 2:197-204.
3. Bagee, M.; Fuda, HI; Mara, H.; Kawamura, H. and Yamauchi (1993): Changes in serum immunoglobulin M (IgM) concentrations during early development of chum salmon as determined by sensitive Elisa technique, Comp. Biochem. Physiology 106A:69-74
4. Barton, B.A.; Peter, R.E. and Paulence C.R. (1980): Plasma cortisol level of fingerling rainbow trout at rest and subjected to handling continent transport and stocking fish Aqua sci'37, 805-811.
5. Berezi, I. (1989) Immunoregulation by neuroendocrine factors Dev, comp Immunol 13:329-341.
6. Chen, Y. (1980): Effect of thyroxine on the immune response of mice invivo and vitro Immunol org 9, 269-276.
7. Defetoff, S. (1979): Thyroid function tests endocrinology Degvoated philadelphia crume and spratton. Vol. 1:387-428.
8. Diesen, P. (1967): Insulin in membrane and metabolism P. Diesen Ed. William and wilkins Bathmore 259-262.
9. Edvington, T.S.; Harvey, R.B.; and Kulena-D.F. (1994): Effect of aflattoxins in growing lambs fed ruminally degradable or escapes protein sources. Journal of Animal science 72 (1274-1281).
10. Fuda, H.; Sayano, K; Yamaji, F. and Haraj. (1991) : Serum immunoglobulin M (IgM) during early development of masu salmon on corhyrchus masu. Comp. Biochem. Physiol, 99A., 637-643.
11. John, F.; Carragler, and Christine, M.R (1994) : Primary and secondary stress responses in golden perch Macquoria ambigua (J. comp. Biochem. Physiol. Vol. 107A No. 1 pp. 40-56 .

12. Hara, A. (1976) Iron binding activity of female specific serum proteins rainbow trout salmon and chum salmon *Oncorhynchus* Journal of Biochem. Physiology 427: 549-557.
13. Hilton, J. W.; Plisetskaya, E.M. and Leatherland, J.F. (1987): Dose oral 3, 5, 3 triiodothyroxine affect dietary glucose utilization and plasma insulin levels in rainbow trout. Fish physiol. Biochem. 4:113-120
14. Ingram, G.A. (1980): Substances involved in the natural resistance of fish to infection. A review J. Fish Biol, 16; 23-60.
15. Matsubara, A.; Mihara, S. and Kusuda, R. (1985) : Quantitation of Yellow tail immunoglobulin by enzyme-linked immunosorbent assay (ELISA) Bull. Japan Soc. Sci. Fish 51, 921-925.
16. Moorehead, M.M, Mazeaud F & Donaldson E.M (1977): Primary and secondary effects of stress fish some new data with a general review trans Am Fish Soc 106, 201-212 .
17. Milne R.S. and Leatherland J. F. (1980) : Changes in plasma thyroid hormones following administration of exogenous pituitary hormones and steroids hormones to rainbow trout, Comp. Biochem. Physiol. 66A 679-686 .
18. Nagae, M; Fuda, H; Hara, A. and Hamuchi, A. (1993): changes in serum immunoglobulin M (IgM) concentrations during early development of chum salmon as determined by sensitive ELISA Comp. Biochem. Physiology pp. (69-74).
19. Osborn, R.H.; Simpson, T.H. and Youngson, A.F. (1978): Seasonal and diurnal rhythms of thyroidal status in the rainbow trout J. Fish Biol, 12, 531-540.
20. Ostrowski, M. (1984): Biochemical and physiological responses of growing chickens and ducklings of dietary aflatoxins. Comp. Biochem. Physiol. 79:1, 193-204.
21. Pickering, A.D. and Pottinger, P. (1983): Seasonal and diet changes in plasma cortisol levels of the brown trout, *Salmo trutta* L. Gen. Comp. Endocrinol., 49; 232-239 .
22. Pickering, A.D. and Pottinger, T. G. (1985): Recovery of the Brown trout *Salmo trutta* from acute handling stress a time-course study J. Fish Biol 20:229-249 .
23. Snedecor, G.W. and Cochran, W.G. (1967): Statistical methods Iowa State University press, Ames USA. pp 327-329 .
24. Sundly, A.; Eliassen, K. A. Blom, A.K. and Asyard, T. (1991): Plasma insulin, glucagon like peptide and glucose levels in response to feeding, starvation, life long restricted fed starvation in salmonids, Fish Journal of physiol. & Biochem. vol. 9 No 3.p 253-259 .
25. Sundly, A.; Eliassen K.; Refstie T., and Plisetskaya E. (1991): Determination of plasma levels of insulin, glucogen and glucogen like peptide in salmonids of different weights fish physiol., Biochem. 9: 223 – 230 .
26. Strange, R.J. (1978): Changes in plasma cortisol concentrations of juvenile salmonids during stress. Ph.D thesis Oregon state University U.S.A.
27. Wedemeyer, G.A (1970) :The role of stress in the disease resistance of fishes spec. Publs Am. Fish soc. 5, 30-35.

2/1/2012

**Genetic Diversity among Eight Egyptian Snakes (Squamata-Serpents: Colubridae) Using RAPD-PCR****Nadia H. M. Sayed**Zoology Dept., College for Women for Science, Arts and Education, Ain Shams University, Heliopolis, Cairo, Egypt. [drlnadiah@gmail.com](mailto:drlnadiah@gmail.com)

**Abstract:** Genetic variations between 8 Egyptian snake species, *Psammophis sibilans sibilans*, *Psammophis Sudanensis*, *Psammophis Schokari Schokari*, *Psammophis Schokari aegyptiacus*, *Spalerosophis diadema*, *Lytorhynchus diadema*, , *Coluber rhodorhachis*, *Coluber nummifer* were conducted using RAPD-PCR. Animals were captured from several locality of Egypt (Abu Rawash-Giza, Sinai and Faiyum). Obtained results revealed a total of 59 bands which were amplified by the five primers OPB-01, OPB-13, OPB-14, OPB-20 and OPE-05 with an average 11.8 bands per primer at molecular weights ranged from 3000-250 bp. The polymorphic loci between both species were 54 with percentage 91.5 %. The mean band frequency was 47% ranging from 39% to 62% per primer. The similarity matrix value between the 8 Snakes species was ranged from 0.35 (35%) to 0.71 (71%) with an average of 60%. The genetic distance between the 8 colubrid species was ranged from 0.29 (29%) to 0.65 (65%) with an average of 40 %. Dendrogram showed that, the 8 snake species are separated from each other into two clusters. The first cluster contain 4 species of the genus *Psammophis*. The second cluster includes the 4 species of the genera, *Spalerosophis*; *Coluber* and *Lytorhynchus*. *Psammophis sibilans* is sister to *Psammophis Sudanensis* with high genetic similarity (71%) and *Psammophis Schokari Schokari* is sister to *Psammophis Schokari aegyptiacus* with high genetic similarity (70%). The *Coluber rhodorhachis* are clustered and closer to *Spalerosophis diadema* (70%) than to *Coluber nummifer* (57%). Therefore, the evolutionary history of snakes still remains controversial. It is concluded that, the similarity coefficient and the genetic distance value between the 8 snake species indicates that, the 8 snake species are not identical and separated from each other.

[Nadia H. M. Sayed **Genetic Diversity among Eight Egyptian Snakes (Squamata-Serpents: Colubridae) Using RAPD-PCR**. Life Science Journal 2012; 9(1):423-430]. (ISSN: 1097-8135). <http://www.lifesciencesite.com>. 63

**Key Words:** *Colubridae*, *Serpents*, RAPD-PCR, Phylogenetic Relationship, Egyptian snakes.

**1. Introduction**

The squamates are the most diversified group containing the lizards and snakes (Vidal and Hedges, 2009). Several investigations have been recorded on the fauna of Egypt reptiles (Anderson 1898; Marx, 1958 and 1968; Werner, 1983; Goodman and Hobbs, 1994). The suborder Serpents is distributed all over the world (McDowell, 1987; Zug et al., 2001). The Superfamily Colubroidea represents nearly 2500 species of extant snakes (Gasperetti, 1988; Pough et al., 2004). The monophyletic Colubroidea Snakes species were established primarily on basis of external and taxonomical features (Zaher, 1999). Also, the herpetological studies are subdivided Colubroidea into the families Viperidae, Elapidae, Atractaspididae, Colubridae (Pough et al., 2004), while Dowling and Jenner (1988) reserved the superfamily Colubroidea to the families Colubridae and Natricidae. Moreover, Zaher et al. (2009) classified the family Psammophidae within the superfamily Elapoidea and the families Colubridae and Natricidae was kept within the superfamily Colubroidea. Also, colubroids have been studied in historical biogeography (Pyron and Burbrink, 2009; Daza et al., 2010). Previous descriptions of the external and taxonomical features of some snakes have been ambiguous and unreliable. Therefore, several authors used the karyological

studies (Pinou and Dowling, 1994), biochemical electrophoresis (Cadle, 1988; Dowling et al., 1996) and molecular sequence analysis (Lawson et al., 2005; Burbrink and Pyron, 2008; Wiens et al., 2008; Kelly et al., 2009; Vidal et al., 2009; Zaher, et al., 2009; Pyron, et al., 2011) to resolve the cladistic relationships among snakes and to clarify their phylogeny. Major changes to colubroid taxonomy have been proposed based on molecular studies (Lawson et al., 2005; Burbrink et al., 2007; Zaher et al., 2009). Also, the molecular RAPD-PCR technique has been used as an important tool in genetic studies of snakes (Prior et al., 1997; Jaggi et al., 2000; Dutra, et al., 2008).

Although their morphology has been investigated previously, there are still major gaps in our knowledge of the relationships of these animals. These gaps may hide important differences between ancient taxonomies and molecular phylogenies which yet, the few species and genera were included in these phylogenies, leaving the classification of many genera in question (Lawson et al., 2005; Kelly et al., 2009; Zaher et al., 2009).

The family Colubridae is the most diverse, widespread, and contains greater than 1800 species within all of Serpents (Pough et al., 2004). Goodman and Hobbs (1994) have been recorded the distribution

of colubrid species of the family colubridae in the northern portion of the Egyptian Eastern Desert. These include: *Coluber florulentus*, *C. rhodorhachis*, *C. rogersi*, *Lytorhynchus diadema*, *Malpolon moilensis*, *Psammophis schokari*, *P. aegyptius*, and *Spalerosophis diadema*. There are areas within Egypt where *P. aegyptius* and *P. schokari* are sympatric and both have been collected in the Egyptian Eastern Desert (Goodman *et al.*, 1985). The classification of this group into subfamilies remain dissenting Topics (McDowell, 1987; Vidal and Hedges, 2002; Kelly *et al.*, 2003; Nagy *et al.*, 2003). The Colubridae comprise 12 subfamilies, Xenodermatinae, Pareatinae, Calamariinae, Homalopsinae, Boodontinae, Pseudoxyrhophiinae, Colubrinae, Pseudoxenodontinae, Natricinae, Dipsadinae, and Xenodontinae (Zaher, 1999). The monophyly of the subfamilies Colubrinae, Natricinae, Psammophiinae, and Xenodontinae appears to be common to several molecular studies (Cadle, 1988; Dowling *et al.*, 1996; Gravlund, 2001; Kelly *et al.*, 2003). While, Dowling and Jenner (1988) reserved the subfamily Colubrinae and Natricinae within the families Colubridae and Natricidae, respectively. Family Colubridae is now represented by twelve genera (*Dolichophis*, *Eirenis*, *Hemorrhphis*, *Lytorhynchus*, *Malpolon*, *Natrix*, *Platyceps*, *Psammophis*, *Rhagerhis*, *Rhynchocalamus*, *Spalerosophis* and *Telescopus*) including 24 species (Amr and Disi, 2011).

The molecular phylogenetic relationships of the colubrid species (subfamily Colubrinae) were recorded by several authors (Lawson *et al.*, 2005; Gravlund, 2001; Kelly *et al.*, 2003).

Kelly, *et al* (2008) found that the family Psammophiidae includes eight genera and about 50 species. Phylogenetic studies of the family Psammophiidae has been establish based on immunological data (Cadle, 1994) and mitochondrial DNA sequences (Gravlund, 2001; Vidal and Hedges, 2002; Nagy *et al.*, 2003; Kelly *et al.*, 2008). The generic diagnosis for Psammophis carried out by Broadley (2002) and Kelly *et al.* (2008). Bons and Geniez (1996) found that the genus *Psammophis* of the subfamily Psammophiinae includes 24 species, most of them with an African origin, but some also occur in the Middle East and Asia. *Psammophis schokari* is widespread in North Africa having a Saharo-Sindian distribution; it is also found in the Middle East, Arabia, Iran, a large part of Afghanistan, Uzbekistan and northwest India (Geniez *et al.* 2004). *Psammophis aegyptius* Marx, 1958, was formerly considered as a subspecies of *Psammophis schokari* but is currently recognized as a distinct species (Schleich *et al.* 1996). In Morocco/Western Sahara, three distinct morphotypes have been recorded for *P. schokari*: the striped form; the unicoloured and the Western-Sahara

form with a slightly less slender body, weakly striped pattern and greyish belly (Bons and Geniez 1996; Rato, *et al.*, 2007). The occurrence of striped and unicoloured morphotypes has also been recorded in Israel and Sinai (Kark *et al.* 1997; Rato *et al.*, 2007). Broadley (1977, 2002) involved the species *schokari*, *aegyptius*, *punctulatus*, *elegans* and *trigrammus* in the “*Psammophis schokari* group”. Kelly *et al.* (2008) noted that the *P. cf. sibilans* (Ethiopian), *P. rukwae*, *P. subtaeniatus*, *P. sudanensis* and *P. orientalis* are involved in the one group. The RAPD technique has been used as a important tool in genetic studies of snakes (Prior *et al.*, 1997; Jaggi *et al.*, 2000; Dutra, *et al.*, 2008). Also, Broadley (1977) reported data of *Psammophis sibilans*.

This investigation aimed to illustrate the genetic diversity between some common Egyptian colubrid snakes of the family Colubridae by using RAPD- PCR technique.

## 2. Materials and Methods

Animal dealer collected eight Egyptian colubrid species (snakes) from different localities of Egypt. The eight species are belonging to four genera. Morphological identification and classification of the animals as well as scientific and common names of these species was carried out according to previous works (Anderson, 1898; Marx, 1968; Goodman and Hobbs, 1994). The studied species are present in Table 1.

### Genomic DNA extraction

Muscle tissue from the snakes were taken and stored at -20 °c. DNA extracted according to the method of Sambrook (1989) with slight modifications. DNA quality and concentration determined by spectrophotometric analysis and run in 0.7 % agarose gel. Each sample of DNA was examined by optical density values at 260 and 280 nm. Optical density ratios evaluated and only good quality DNA samples were used in PCR.

### RAPD-PCR reaction

15 primers from Kits OP-B , OP-E and OP-O (Operon Technologies, Alameda, CA, USA) used for RAPD-PCR analysis (OPB-01, OPB-05, OPB-09, OP-10, OPB-12, OPB-13, OP-B14, OPB-17, OPB-19, OP-B20, OPE-01, OPE-05 OPE-10, OPO-01 and OPO-03). Only 10 primers (OPB-01, OPB-09, OPB-12, OPB-13, OPB-14, OPB-17, OPB-19, OPB-20, OPE-05 and OPO-03) were reacted well and used to amplify DNA from all species (table 2). It selected five primers (OPB-01, OPB-13, OPB-14, OPB-20 and OPE-05) (fig. 1-5) which had shown some variation among eight snake species. RAPD-PCR reactions carried out as described by Williams *et al.*, (1993). PCR cycles

performed with 60 s, 94°C initial denaturation and 35 cycles of 20 s, 94°C; 20 s 35°C; and 30 s 72°C. Final extension performed at 72°C for 5 min. PCR amplifications were carried out in 96 well Thermal cycler (Eppendorf Master Cycler) and all amplifications were carried out at two times. A PCR mixture without template DNA placed in each analysis as a control. The PCR products separated on 1.5 % agarose gels (Sigma) containing ethidium bromide in 0.5 X TBE buffer at 100 V constant voltages. For evaluating the base pair length of bands, DNA ladder (Fermentas) was loaded with each gel.

### Data and statistical analysis:

The RAPD banding patterns scored for the presence (1) and absence (0) of bands for each sample. The scores obtained using all primers in the RAPD analysis combined to create a single data matrix. The statistical analysis of the data included the calculation of allele frequencies according to Nei (1987) and the number and percentage of polymorphic loci according to Nei (1973). Genetic similarity and genetic distance were estimated among species according to Nei and Li (1979). Based on the genetic similarity matrix, the species were clustered by the unweighted pair group method with arithmetic averaging (UPGMA) using the program NTSYS-pc version 2.1 (Rohlf, 1999).

**Table 1. Scientific name, Common name, Arabic name and locality of eight Egyptian snakes**

No.	Scientific name	Common name	locality
1	<i>Psammophis sibilans sibilans</i> , (Linnaeus, 1758)	African Beauty snake, Abu Essuyur	Abu Rawash-Giza
2	<i>Psammophis Sudanensis</i>	Sudanensis snake	Faiyum- Cairo
3	<i>Psammophis Schokari Schokari</i>	Schokari Sand snake	Abu Rawash-Giza
4	<i>Psammophis Schokar aegyptius</i> , (Marx, 1858)	Egyptian Sand snake, Saharan Sand snake, Harseen	Egyptian Sahara, Faiyum
5	<i>Spalerosophis diadema</i> , (Schlegel, 1837)	Clifford's Royal snake, Arqam Ahmar	Abu Rawash-Giza
6	<i>Lytorhynchus diadema</i> , (Dumeril, Bibron and Dumeril, 1854)	Diademed Sand Snake, Bisbas	Abu Rawash-Giza
7	<i>Coluber rhodorhachis rhodorhachis</i> , (Jan, 1865)	Azrude Gabaly, Jan's Desert Racer	Sinai
8	<i>Coluber nummifer</i> , (Reuss, 1834)	Coin Marked Snake, Arqam Baity	Sinai

**Table 2: Sequence of primers employed in molecular phylogenetic relationship among eight snake species**

Primers	Sequence	
B-01	5'-GTTTCGCTCC-3'	60%
B-09	5'-TGGGGGACTC-3'	70%
B-12	5'-CCTTGACGCA-3'	60%
B-13	5'-TTCCCCGCT-3'	70%
B-14	5'-TCCGCTCTGG-3'	70%
B-17	5'-AGGGAACGAG-3'	60%
B-19	5'-ACCCCGAAG-3'	70%
B-20	5'-GGACCCTTAC-3'	60%
E-05	5'-TCAGGGAGGT-3'	60%
O-03	5'-CTGTTGCTAC-3'	50%

### 3. Results

In the present study, only selected five primers (OPB-01, OPB-13, OPB-14, OPE-05 and OPB-20) out of the 15 random primers produced a PCR product for the investigation of the genetic variation between the eight studied serpents (colubrid) species. The primer

B-13 produces much more of amplified fragments for the genomic DNA of the 8 colubrid species in comparison to the other primers. The five primers established 59 different bands scored for the presence or absence of bands among the eight snake species. The results of the RAPD analysis are present in the table (3) in which a total of 59 scorable amplified bands with an average 11.8 bands/primer at molecular weights ranged from 3000 to 250 bp between the eight colubrid species. Out of them 54 (91.5%) polymorphic bands were recorded with an average 10.8 bands/primer. The numbers of RAPD bands are ranged from 10 to 17 bands/primer with polymorphic bands ranging from 7 to 16 per primer. The RAPD profile generated from these primers (Figs. 1, 2, 3, 4 and 5) and the RAPD scoring bands have utilized to estimate the band frequency. The mean band frequency was 47% for all snakes ranging from 39% to 62% per primer. The unique band ranged from 0 to 3.

The similarity matrix among the eight species is presented in table (4) which was estimated based on RAPD bands scored. The mean similarity coefficient value between the eight snake species was ranged from



0.35 (35 %) to 0.71 (71 %) with an average of 0.60 (60%). The genetic distance between the eight species was ranged from 0.29 (29 %) to (65 %) with an average of 0.40 (40 %). The species of *Psammophis sibilans sibilans* and *Psammophis sudanensis*, are closer to each other which have low genetic variation and high genetic similarity (71%). Also, *Psammophis schokar schokar* and *Psammophis schokari aegyptiacus* are nearer to each other with high genetic similarity (70%). *Psammophis sibilans* is more similar to *Psammophis sudanensis* than *Psammophis schokar schokar* (56 %) and *Psammophis Schokari aegyptiacus* (57%). The Colubrid, *Coluber rhodorhachis* is closer to the *Spalerosophis diadema* (70 %) than the *Coluber nummifer* (58 %). Moreover, The *Lytorhynchus diadema* in the separate clade of the subfamily colubrinae is more similar to *Coluber nummifer* (54 %) than to *Coluber rhodorhachis* (52 %) and *Spalerosophis diadema* (50%).

The UPGMA dendrogram was constructed to show phylogenetic relationships among the 8 snake species based on genetic similarity (Fig. 5). The phylogenetic

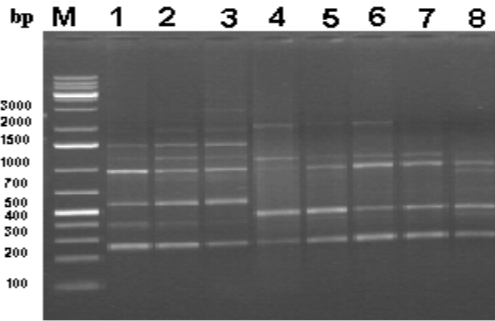
tree constructed using an unweighted pair group method with arithmetic (UPGMA) method and similarity matrix indicates that the eight snakes are clustered into two main clusters. The first cluster contains 4 snake species belong to the subfamily Psammophinae. Within the subfamily Psammophinae, the four species are collected in two clades which *Psammophis sibilans* is sister to *Psammophis sudanensis* in the first clade with high genetic similarity (71%) and *Psammophis schokar schokar* is sister to *Psammophis schokari aegyptiacus* in the second clade with high genetic similarity (70%). The second cluster includes 4 colubrid species belong to the subfamily Colubrinae. Within the subfamily Colubrinae, the four species are grouped in two major clades, the *Lytorhynchus diadema* first clade and *Spalerosophis diadema*, *Coluber rhodorhachis* and *Coluber nummifer* second clade. The *Spalerosophis diadema* and *Coluber rhodorhachis* are sister clade to each other with high genetic similarity (70%) and the two species form a common branch which clustered with *Coluber nummifer*.

**Table 3:** Total number of bands, polymorphic bands, % of polymorphic bands, Mean band frequency, Unique bands and their size range (bp) for different primers of eight colubrid species.

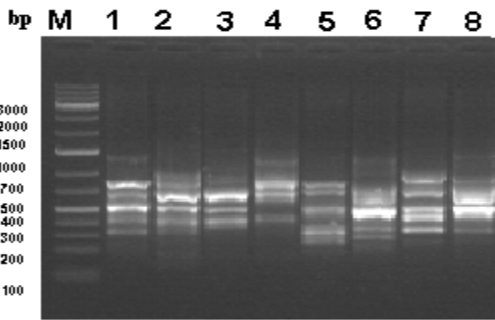
Primers	Total No. bands	No. polymorphic bands	% of polymorphic bands	Band frequency	Mean sharing band frequency	Unique band	Size range (bp)
OP-B13	17	16	94.1%	0.13-1	0.41	3	3000-250
OP-B14	12	12	100%	0.25-0.75	0.40	1	2400-220
OP-B1	10	7	70%	0.13-1	0.62	2	2600-250
OP-E5	10	9	90%	0.25-1	0.58	0	1400-250
OP-B20	10	10	100%	0.13-0.63	0.39	0	1300-250
Total (average)	59(11.8)	54(10.8)	91.5 %		0.47		3000-250

**Table 4:** The similarity matrix and genetic distances among the eight snake species (according to Nei and Li, 1979).

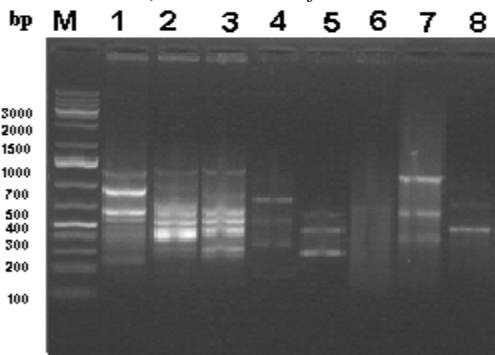
	1	2	3	4	5	6	7	8
1		0.290	0.443	0.429	0.520	0.542	0.538	0.556
2	0.710		0.429	0.442	0.538	0.516	0.52	0.607
3	0.557	0.571		0.302	0.649	0.564	0.593	0.509
4	0.571	0.586	0.698		0.538	0.600	0.481	0.464
5	0.480	0.462	0.351	0.462		0.500	0.300	0.360
6	0.458	0.484	0.436	0.400	0.500		0.478	0.458
7	0.462	0.480	0.407	0.519	0.700	0.522		0.423
8	0.444	0.393	0.492	0.536	0.640	0.542	0.577	



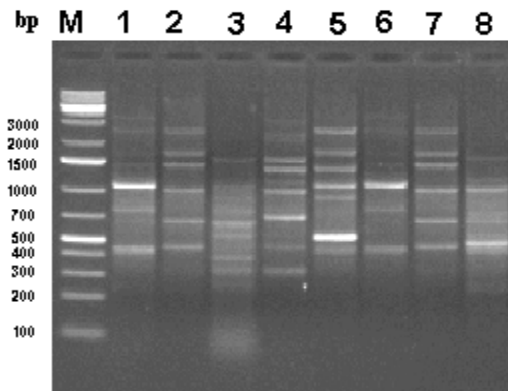
**Figure 1:** Gel electrophoresis represents RAPD -PCR products for DNA from eight colubrid species (Lanes 1 to 8) with OPB-01 primer. M, DNA marker with molecular size, (1kb plus, Fermantas). 1, *Psammophis sibilans sibilans*; 2, *Psammophis Sudanensis*; 3, *Psammophis Schokari Schokari*; 4, *Psammophis Schokari aegyptiacus*; 5, *Spalerosophis diadema*; 6, *Lytorhynchus diadema*; 7, *Coluber rhodorhachis rhodorhachis*; 8, *Coluber nummifer*.



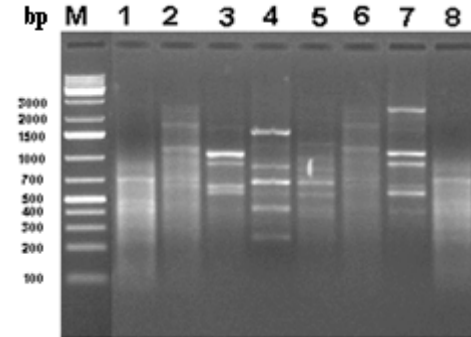
**Figure 2:** Gel electrophoresis represents RAPD -PCR products for DNA from eight colubrid species (Lanes 1 to 8) with OPE-5 primer. M, DNA marker with molecular size (1kb plus, Fermantas). 1, *Psammophis sibilans sibilans*; 2, *Psammophis Sudanensis*; 3, *Psammophis Schokari Schokari*; 4, *Psammophis Schokari aegyptiacus*; 5, *Spalerosophis diadema*; 6, *Lytorhynchus diadema*; 7, *Coluber rhodorhachis rhodorhachis*; 8, *Coluber nummifer*.



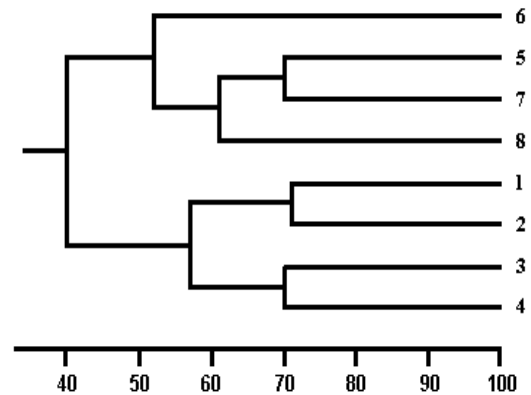
**Figure 3:** Gel electrophoresis represents RAPD -PCR products for DNA from eight colubrid species (Lanes 1 to 8) with OPB-20 primer. M, DNA marker with molecular size, (1kb plus, Fermantas). 1, *Psammophis sibilans sibilans*; 2, *Psammophis Sudanensis*; 3, *Psammophis Schokari Schokari*; 4, *Psammophis Schokari aegyptiacus*; 5, *Spalerosophis diadema*; 6, *Lytorhynchus diadema*; 7, *Coluber rhodorhachis rhodorhachis*; 8, *Coluber nummifer*.



**Figure 4:** Gel electrophoresis represents RAPD -PCR products for DNA from eight colubrid species (Lanes 1 to 8) with OPB-13 primer. M, DNA marker with molecular size, (1kb plus, Fermantas). 1, *Psammophis sibilans sibilans*; 2, *Psammophis Sudanensis*; 3, *Psammophis Schokari Schokari*; 4, *Psammophis Schokari aegyptiacus*; 5, *Spalerosophis diadema*; 6, *Lytorhynchus diadema*; 7, *Coluber rhodorhachis rhodorhachis*; 8, *Coluber nummifer*.



**Figure 5:** Gel electrophoresis represents RAPD -PCR products for DNA from eight colubrid species (Lanes 1 to 8) with OPB-14 primer. M, DNA marker with molecular size (1kb plus, Fermantas). 1, *Psammophis sibilans sibilans*; 2, *Psammophis Sudanensis*; 3, *Psammophis Schokari Schokari*; 4, *Psammophis Schokari aegyptiacus*; 5, *Spalerosophis diadema*; 6, *Lytorhynchus diadema*; 7, *Coluber rhodorhachis rhodorhachis*; 8, *Coluber nummifer*.



**Figure (6):** UPGMA based Dendrogram showing phylogenetic relationships among the eight colubrid species (1-8) based on RAPD-PCR by OPB-01, OPB-13, OPB-14, OPE-05 and OPB-20 primers.

#### 4. Discussion

- The higher-level classification of Colubroidea has been in change as new molecular results contradict traditional taxonomy, and new phylogenies and taxonomies contradict each other (**Burbrink et al., 2007; Wiens et al., 2008; Zaher et al., 2009**). In the present work, the family colubridae is separated into two subfamilies, Psammophiinae and Colubrinae. These divisions were similar to those mentioned by **Vidal and Hedges (2002), Kelly et al. (2003)** and **Lawson et al. (2005)**. **Vidal et al. (2007)** recognized Lamprophiidae as a single family, including Psammophiinae subfamily and genus *Psammophis* which is supported by **Gravlund (2001)**. The snake *Psammophis schokari* has a widespread distribution across North Africa, Morocco and Western Sahara and is represented by three different morphotypes: striped, unicoloured and the Western-Sahara morphology (**Bons and Geniez 1996**). The three Moroccan/Western Sahara color morphotypes form one genetic lineage, indicating that colour pattern and does not reflect a different phylogenetic history, and is probably an ecological adaptation to the local environment (**Rato et al., 2007**). **Broadley (2002)** and **Kelly et al. (2008)** studied the morphology of *Psammophis schokari* group which included the species *schokari*, *aegyptius*, *punctulatus*, *elegans* and *trigrammus*. *P. schokari* shows a genetic diversity ranging from 4–5%, in four different localities (Morocco/Western Sahara, Mauritania and Algeria). Surprisingly, Moroccan/Western Sahara and Algerian lineages are the most divergent ones. This geographic substructuring may be due to severe climate changes in the Sahara desert between the Miocene and Pleistocene associated with expansion/contraction phases of this desert. *Psammophis aegyptius* is sister taxon of *Psammophis schokari* with a high level of genetic divergence between them (10.7%) supporting the recognition of *P. aegyptius* as a distinct species (**Schleich et al. 1996; Rato et al., 2007**). Also, in the present work *Psammophis schokari aegyptius* is sister taxon to *Psammophis schokari schokari* with high genetic diversity between them (30.2%). **Largen and Rasmussen (1993)** and **Rato, et al., (2007)** examined a large samples of *Psammophis sibilans* and found the vast majority to agree with Egyptian *P. sibilans* in their infralabial arrangement. **Kelly et al. (2008)** found that the *P. sudanensis* and *P. sibilans* are established in the same clade. These results are similar to our results which we found that the two species *P. sibilans* and *P. sudanensis* are presented in the same clade and the genetic similarity is 71% between them. In addition, the northern stripe-bellied sand snake, *P. sudanensis* is synonym to *P. subtaeniatus* (**Howell, 2000**).
- The Colubrinae is the largest subfamily within the family Colubridae. **Lawson et al. (2005)** show that the genus *Lytorhynchus* is sister to a clade composed of the genera *Spalerosophis* and *Coluber*. This result

is similar to that found in the present work. Additionally, the *Spalerosophis diadema* and *Coluber rhodorhachis* are monophyletic (sister) to each other in one clade and these group of the two species is sister to clade contains *Coluber nummifer*. These results are similar to that recorded by **Lawson et al. (2005), Nagy et al. (2004)** and **Pyron et al. (2011)**. The closely related species, *Platyiceps (Coluber) rhodorachis*, *Platyiceps (Coluber) rogersi* and *Platyiceps (Coluber) florulentus* have high genetic diversity (7%) with *Spalerosophis diadema* and the morphological and molecular studies DNA were indicated a common origin between the genera *Platyiceps (coluber)* and *Spalerosophis (Schatti and Utiger, 2001)*. Also, in the present work there is a close relation between *Coluber rhodorachis* and *Spalerosophis diadema* but the genetic diversity between them is 30%. Surprisingly, *Coluber rhodorhachis* and *Coluber nummifer* are the most divergent ones but *Coluber rhodorhachis* and *Spalerosophis diadema* are the most similarity ones. Therefore, the evolutionary history of snakes still remains controversial.

- The similarity matrix between the eight varieties ranged from 35% to 71% with an average 60% (table 5). In conclusion, the similarity coefficient between the eight snake species indicates that the 8 snake species are not identical and separated from each other.

#### Corresponding author

Nadia H. M. Sayed

Zoology Dept., College for Women for Science, Arts and Education, Ain Shams University, Heliopolis, Cairo, Egypt.

[dr1nadiah@gmail.com](mailto:dr1nadiah@gmail.com)

#### References

- Amr, Z. S. and Disi, A. M. (2011)**. Systematics, distribution and ecology of the snakes of Jordan. *Vertebrate Zool.*, 61 (2): 179-266
- Anderson, J. (1898)**. Zoology of Egypt. Volume 1, Reptilia and Batrachia. London: B. Quaritch. 371 pp.
- Bons, J. and Geniez, P. (1996)**. Amphibians and Reptiles of Morocco. (Including Western Sahara), Biogeographical Atlas. Asociación Herpetológica Española, Barcelona.
- Broadley, D.G. (1977)**. A review of the Genus *Psammophis* in southern Africa (Serpentes: Colubridae). *Arnoldia (Rhod.)*, 8: 1–29.
- Broadley, D.G. (2002)**. A review of the species of *Psammophis* Boie found south of Latitude 12 S (Serpentes: Psammophiinae). *Afr. J. Herpetol.*, 51: 83–119.
- Burbrink, F.T.; Crother, B.I. and Lawson, R. (2007)**. The destabilization of North American snake taxonomy. *Herp. Rev.*, 38: 273–278.

7. **Burbrink, F.T. and Pyron, R.A. (2008).** The taming of the skew: estimating proper confidence intervals for divergence dates. *Syst. Biol.*, 57: 317–328.
8. **Cadle, J. E. (1988).** Phylogenetic relationships among advanced snakes: A molecular perspective. *Univ. Calif. Publ. Zool.*, 119: 1-77.
9. **Cadle, J.E., (1994).** The colubrid radiation in Africa (Serpentes: Colubridae) phylogenetic relationships and evolutionary patterns based on immunological data. *Zool. J. Linn. Soc.*, 110: 103–140.
10. **Daza, M.; Castoe, A. and Parkinson, L. (2010).** Using regional-scale comparative phylogeographic data to infer historical processes in Middle America. *Ecography*, 33: 343–354.
11. **Dowling, H. G.; Hass, C. A.; Hedges, S. B. and Highton R. (1996).** Snake relationships revealed by slow-evolving proteins: a preliminary survey. *J. Zool. Lond.*, 240:1-28.
12. **Dowling, H.G. and Jenner, J.V. (1988).** Snakes of Burma. Checklist of reported species and bibliography. Smithsonian Herpetological Information Service 76.
13. **Dutra, N.C.L.; Telles, M.P.C.; Dutra D.L. and Silva Júnior N.J. (2008).** Genetic diversity in populations of the viper *Bothrops moojeni* Hoge, 1966 in Central Brazil using RAPD markers. *Genet. Mol. Res.*, 7 (3): 603-613.
14. **Gasperetti, J. (1988).** Snakes of Arabia. *Fauna of Saudi Arabia*, 9: 169-450.
15. **Geniez, P.; Mateo, J.A.; Geniez, M. and Pether, J. (2004).** The Amphibians and Reptiles of the Western Sahara: An Atlas and Field Guide. Chimaira, Frankfurt.
16. **Goodman, S. M. and Hobbs, J. J. (1994).** The distribution and ethnozoology of reptiles of the northern portion of the Egyptian Eastern Desert. *J. Ethnobiol.*, 14(1): 75–100.
17. **Goodman, S. M.; Kraus, F. and Baha El Din, S. M. (1985).** Records of terrestrial reptiles from Egyptian Red Sea Islands. *Egypt. J. Wildlife Nat. Res.*, 6: 26-31.
18. **Gravlund, P. (2001).** Radiation within the advanced snakes (Caenophidia) with special emphasis on African opisthophthalmid colubrids, based on mitochondrial sequence data. *Biol. J. Linn. Soc.*, 72: 99–114.
19. **Howell, K.; Msuya, C. and Kihale, P. (2000).** A Preliminary Biodiversity (Fauna) Assessment of the Rufiji Floodplain and Delta. REMP Technical Report 9.
20. **Jaggi C.; Wirth T. and Baur B. (2000).** Genetic variability in subpopulations of the asp viper (*Vipera aspis*) in the Swiss Jura Mountains: implications for a conservation strategy. *Biol. Conserv.*, 94: 69-77.
21. **Kark, S.; Warburg, I. and Werner, Y.L. (1997).** Polymorphism in the snake *Psammophis schokari* on both sides of the desert edge in Israel and Sinai. *J. Arid Environ.*, 37: 513-527.
22. **Kelly, C.M.R.; Barker, N.P.; Villet, M.H. and Broadley, D.G. (2009).** Phylogeny, biogeography and classification of the snake superfamily Elapoidea: a rapid radiation in the late Eocene. *Cladistics*, 25: 38–63.
23. **Kelly, C.M.R.; Barker, N.P.; Villet, M.H.; Broadley, D.G. and Branch, W.R. (2008).** The snake family Psammophiidae (Reptilia: Serpentes): Phylogenetics and species delimitation in the African sand snakes (*Psammophis* Boie, 1825) and allied genera. *Mol. Phylogenet. Evol.*, 47: 1045-1060.
24. **Kelly, C.M.R.; Barker, N.P. and Villet, M.H. (2003).** Phylogenetics of advanced snakes (Caenophidia) based on four mitochondrial genes. *Syst. Biol.*, 52: 439–459.
25. **Largen, M.J. and Rasmussen, J.B. (1993).** Catalogue of the snakes of Ethiopia (Reptilia: Serpentes), including identification keys. *Trop. Zool.*, 6: 313–434.
26. **Lawson, R.; Slowinski, J.B.; Crother, B.I. and Burbrink, F.T. (2005).** Phylogeny of the Colubroidea (Serpentes): new evidence from mitochondrial and nuclear genes. *Mol. Phylogenet. Evol.*, 37: 581–601.
27. **Marx, H. (1958).** Catalogue of type specimens of reptiles and amphibians in Chicago Natural History Museum. *Fieldiana Zool.*, 36: 407-496.
28. **Marx, H. (1968).** Checklist of the reptiles and amphibians of Egypt. Cairo: U.S. Naval Medical Research Unit Number Three. 91 pp. (Special Publication.)
29. **McDowell, S.B. (1987).** Systematics. In: Seigel, R.A., Collins, J.T., Novak, S.S. (Eds.), *Snakes: Ecology and Evolutionary Biology*. Macmillan Publishing, New York, NY, pp. 3–50.
30. **Nagy, Z.T.; Joger, U.; Wink, M.; Glaw, F. and Vences, M. (2003).** Multiple colonization of Madagascar and Socotra by colubrid snakes: evidence from nuclear and mitochondrial gene phylogenies. *Proc. R. Soc. Lond. B.*, 270: 2613–2621.
31. **Nagy, Z.T.; Lawson, R.; Joger, U. and Wink, M. (2004).** Molecular systematics of racers, whip snakes and relatives (Reptilia: Colubridae) using mitochondrial and nuclear markers. *J. Zool. Syst. Evol. Res.*, 42: 223–233.
32. **Nei, M. and Li, W. H. (1979).** Mathematical models for studying genetic variation in terms of restriction endonucleases. *Proc. Nat. Acad. Sci. USA*, 76: 5269-5273.
33. **Nei, M. (1973).** Analysis of gene diversity in subdivided populations. *Proc. Natl. Acad. Sci. USA*, 70: 3321-3323.
34. **Nei, M. (1987).** *Molecular evolutionary genetics*. Columbia University Press, New York.
35. **Pinou, T. and Dowling, H. G. (1994).** The phylogenetic relationships of the Central American snake *Tretanorhinus*: data from morphology and karyology. *Amphibia-Reptilia*, 15: 297-305.

36. **Pough, H.F.; Andrews, R.M.; Cadle, J.E.; Crump, M.L.; Savitsky, A.H. and Wells, K.D. (2004).** Herpetology. Third Edition, Pearson Prentice Hall, Upper Saddle River, NJ.
37. **Prior, K.A.; Gibbs, H.L. and Weatherhead, P.J. (1997).** Population genetic structure in the black rat snake: implications for management. *Conserv. Biol.*, 11: 1147-1158.
38. **Pyron, R.A. and Burbrink, F.T. (2009).** Can the Tropical Conservatism Hypothesis explain temperate species richness patterns? An inverse latitudinal biodiversity gradient in the New World snake tribe Lampropeltini. *Glob. Ecol. Biogeogr.*, 18: 406–415.
39. **Pyron, R.A.; Burbrink, F.T.; Colli, G.R.; Montes de Oca, A.N.; Vitt, L.J.; Kuczynski, C.A. and Wiens, J.J. (2011).** The phylogeny of advanced snakes (Colubroidea), with discovery of a new subfamily and comparison of support methods for likelihood trees. *Mol. Phylogenet. Evol.*, 58(2): 329–342.
40. **Rato, C.; Brito, J.C.; Carretero, M.A.; Larbes, S.; Shacham, B. and Harris, D.J. (2007).** Phylogeography and genetic diversity of *Psammophis schokari* (Serpentes) in North Africa based on mitochondrial DNA sequences. *Afri. Zool.*, 42: 112-117.
41. **Rohlf, F.J. (1999).** NTSYS-PC: Numerical Taxonomy and Multivariate Analysis System (version 2.1); Exeter Software: Setauket, NY, USA.
42. **Sambrook, J.; Fritsch, E. F. and Maniatis, T. (1989).** Molecular cloning : a lab manual, 2<sup>nd</sup> edition. Cold Spring Harbor Laboratory, Cold Spring Harbor, New York
43. **Schattli, B. and Utiger, U. (2001).** *Hemerophis*, a new genus for *Zamenis socotrae* Günther, and a contribution to the phylogeny of Old World racers, whip snakes, and related genera (Reptilia: Squamata: Colubrinae). *Revue Suisse de Zoologie*, 108 (4): 919-948
44. **Schleich, H.H.; Kästle, W. and Kabisch, K. (1996).** Amphibians and Reptiles form North Africa. Koeltz Scientific Publications, Königstein, Germany.
45. **Vidal, N. and Hedges, S.B. (2009).** The molecular evolutionary tree of lizards, snakes, and amphisbaenians. *C. R. Biol.*, 332: 129–139.
46. **Vidal, N. and Hedges, S.B. (2002).** Higher-level relationships of caenophidian snakes inferred from four nuclear and mitochondrial genes. *Comptes Rendus de l'Academie des Sciences, Paris Biol.*, 325: 987–995.
47. **Vidal, N.; Delmas, A.-S.; David, P.; Cruaud, C.; Couloux, A. and Hedges, S.B. (2007).** The phylogeny and classification of caenophidian snakes inferred from seven nuclear protein-coding genes. *C.R. Biol.*, 330: 182–187.
48. **Vidal, N.; Rage, J.-C.; Couloux, A. and Hedges, S.B. (2009).** Snakes (Serpentes). In: Hedges, S.B., Kumar, S. (Eds.), *The Time tree of Life*. Oxford University Press, New York, pp. 390–397.
49. **Werner, Y. L. (1983).** Lizards and snakes from eastern Lower Egypt in the Hebrew University of Jerusalem and Tel Aviv University with range extensions. *Herp. Review*, 14 (1): 29-31.
50. **Wiens, J.J.; Kuczynski, C.A.; Smith, S.A.; Mulcahy, D.G.; Sites Jr., J.W.; Townsend, T.M. and Reeder, T.W. (2008).** Branch lengths, support, and congruence: testing the phylogenomic approach with 20 nuclear loci in snakes. *Syst. Biol.*, 57: 420–431.
51. **Williams, J.; Hanafey, M.; Rafalski, J. and Tingey, S. (1993).** Genetic analysis using random amplified polymorphic DNA markers. *Methods Enzymol.*, 218: 704-740.
52. **Zaher, H. (1999).** Hemipenial morphology of the South American xenodontine snakes, with a proposal for a monophyletic Xenodontinae and a reappraisal of colubroid hemipenes. *Bull. Am. Mus. Nat. Hist.*, 240: 1–168.
53. **Zaher, H.; Grazziotin, F.G.; Cadle, J.E.; Murphy, R.W.; Moura-Leite, J.C. and Bonatto, S.L. (2009).** Molecular phylogeny of advanced snakes (Serpentes, Caenophidia) with an emphasis on South America xenodontines: a revised classification and descriptions of new taxa. *Pap. Av. Zool.*, 49: 115–153.
54. **Zug, G. R.; Vitt, L. J. and Caldwell, J .P. (2001).** Herpetology: An Introductory Biology of Amphibians and Reptiles. Academic Press, New York.

2/2/2012

## Effect of Diabetes Mellitus on Patients Undergoing Laparoscopic Cholecystectomy: A Comparative Cross-Sectional Study

Saleh M. Aldaqal<sup>1</sup>, Alia T. Albaghdadi<sup>1</sup>, Hanaa M. Tashkandi<sup>1</sup>, Basem S. El-deek<sup>2</sup>, Ghada A. Al-Malki<sup>1</sup>, Ali M. Turki<sup>1</sup>, and Ahmed M. Makki<sup>1</sup>

<sup>1</sup> Department of Surgery, Faculty of Medicine, King Abdulaziz University, Jeddah, Kingdom of Saudi Arabia

<sup>2</sup> Department of Community Medicine, Faculty of Medicine, King Abdulaziz University, Jeddah, Kingdom of Saudi Arabia and Mansoura University, Egypt

[sdaqal@yahoo.com](mailto:sdaqal@yahoo.com)

**Abstract:** Diabetes was found to be a risk factor for gallstone formation, and complications. Diabetic patients are generally more prone to operative and post-operative morbidities than their normal counterparts. This study aimed to find whether diabetes is an independent risk factor for morbidities associated with laparoscopic cholecystectomy in our population. **Material and Methods:** This is a comparative cross-sectional study that was conducted at the Department of Surgery in King Abdulaziz University Hospital, Jeddah, Saudi Arabia, from June to December 2011. A total of 112 patients who have undergone laparoscopic cholecystectomy at our hospital were randomly selected and retrieved from the medical records department. Ethical Approval to conduct the study was obtained from the local ethical committee of King Abdulaziz University Hospital. A Performa designed by the study team was used to collect the data. **Results:** A total of 112 patients underwent laparoscopic cholecystectomy for cholelithiasis. 18 patients were male (16.1%) and 94 were female (83.9%) with a ratio of 1:5.2. The mean ( $\pm$ SD) age was  $41.23 \pm 13.82$  years (range 15-75 years). Out of 112 patients, 18 were diabetics (16.1%) and 94 patients (83.9%) were not diabetics. The operation was performed as an elective procedure in 104 patients (92.9%) and as an emergency in 8 patients (7.1%). Diabetics had a significantly higher rate of emergency admissions (22.2%) compared to non-diabetics (4.3%,  $p=0.022$ ). Laparoscopic cholecystectomy was converted to open procedure in 5 patients (4.5%) of which 3 were diabetics (16.7%) and 2 non-diabetics (2.1%). This shows a statistically significant higher ( $p=0.029$ ) rate of conversion to open of diabetics compared to non-diabetics. Diabetics had a significantly higher ( $p=0.029$ ) mean length of post-operative hospital stay ( $2.06 \pm 1.60$ ) compared to non-diabetics ( $1.43 \pm 0.96$ ). The level of HbA1c and fasting glucose level showed no significant effect on conversion to open procedure. The factors that were associated with higher risk of conversion to open were older age ( $p=0.004$ ), male gender ( $p=0.029$ ), diabetes ( $p=0.029$ ), and acute calculous cholecystitis. **Conclusion:** Diabetes mellitus is associated with more emergency admission due to complicated cholelithiasis, more conversion rate from laparoscopic to open cholecystectomy and prolonged post-operative hospital stay. We found that neither fasting blood glucose level nor HbA1c level have any correlation with intraoperative or post-operative complication or conversion rate. We still however recommend a pre-operative control of blood glucose until we have a prospective randomized control trial comparing diabetic and non-diabetics patient going for laparoscopic cholecystectomy to know at which level of HbA1c or level of blood glucose should be achieved before surgery.

[Saleh M. Aldaqal, Alia T. Albaghdadi, Hanaa M. Tashkandi, Basem S. El-deek, Ghada A. Al-Malki, Ali M. Turki and Ahmed M. Makki. **Effect of Diabetes Mellitus on Patients Undergoing Laparoscopic Cholecystectomy: A Comparative Cross-Sectional Study.** Life Science Journal 2012; 9(1):431-439]. (ISSN: 1097-8135). <http://www.lifesciencesite.com>. 64

**Key words:** Diabetes mellitus, laparoscopic cholecystectomy, open cholecystectomy, gall bladder, gall stone.

### 1. Introduction:

Diabetes in Saudi Arabia is a tremendous health problem. The prevalence has reached to one of the highest in the world, affecting 23.7% of the Saudi population (1). It has significantly affected the morbidity and mortality of our population due to its numerous complications and associated comorbidities.

From a surgical point of view, diabetes was found to be a risk factor for gallstone formation, and complications. Furthermore, diabetic patients are

generally more prone to operative and post-operative morbidities than their normal counterparts.

This study aimed to find whether diabetes is an independent risk factor for morbidities associated with laparoscopic cholecystectomy (lap chole) in our population, to find out whether diabetics with a controlled disease have a better outcome than those with an uncontrolled disease, and to see whether the levels of blood glucose and HbA1c correlate with a higher risk of developing complications. It would also help us identify high-risk patients in lap chole and predict the complications that may be

encountered intra-operatively and post-operatively in that specific group of patients, and hence take precautions to achieve best possible outcome.

Identifying such a common disease as a risk factor for complications in a common procedure will improve preparation and communication with patients prior to operating.

## 2. Materials and Methods

### Study Design

This is a comparative cross-sectional study that was conducted at the Department of Surgery in King Abdulaziz University Hospital, a tertiary care center and a teaching hospital in Jeddah, Saudi Arabia. The study was conducted over a period of 7 months (June - December 2011).

A total of 112 patients who has undergone laparoscopic cholecystectomy at the hospital were randomly selected. Ethical Approval to conduct the study was obtained from the local ethical committee of king Abdulaziz university hospital. A Preforma designed by the study team was used to collect the data.

Laparoscopic cholecystectomy at our hospital is usually performed by experienced consultant surgeons or senior residents under the supervision of a consultant. Pre-operative work up is done for all patients on the day of admission. Those include; Liver Function Tests, Coagulation profile, Pre-operative abdominal ultrasound to confirm diagnosis, to look at the site of stones, to measure wall thickness, and look for evidence of inflammation. All patients are also assessed pre-operatively by anesthetists to evaluate co-morbidities, and fitness for surgery.

Following the surgical procedure an operative note is recorded, that includes the duration of operation, and any complications that were encountered during the procedure. The gallbladder specimen is sent for histopathological evaluation. Patients are then transferred to the surgical ward or the surgical ICU at our hospital depending on their condition. Patients are closely monitored in the 1<sup>st</sup> 24 hours post operatively, and if well are discharged on the following day. The usual post-operative hospital stay is one day. Patients are then given follow up appointments at the surgery outpatient clinic of King Abdulaziz University Hospital, and are told to return to the ER in case of any significant related complaint, such as fever, persistent abdominal pain, vomiting, or jaundice. Patients are usually seen within 2 weeks post-operatively, to evaluate the port-site incision and to look for any late complications of Laparoscopic cholecystectomy.

On reviewing their files, Demographic data that is age, gender, and nationality was obtained for all

patients to allow for comparison and to eliminate any confounding variables. The Patients were classified as diabetic - designated group 1 - or not diabetic - designated group 2 - This classification was based on the medical history found in their records and by checking their medication records for any anti-diabetic medications. Blood glucose measurements were done to confirm presence of diabetes.

### Group 1 - Diabetics

Pre-operative glucose level and HbA1c were done for all patients. Those levels were recorded in order to see if there was any correlation between the outcome of lap chole with the level of HbA1c, and glucose levels among the diabetic group (Group1). We also recorded the type of diabetes (Type 1 or Type 2), the control of the disease based on the presence of complications found in their medical records, and also the duration of their disease calculated from the time of diagnosis of diabetes. Those parameters were recorded for comparison of complications within the diabetic group (Group 1).

The results of the routine pre-operative workup was also reviewed and recorded for all patients. We looked at their liver function tests to see if there was any association between the elevation of specific biomarker and the risk of complications. Also, the results of the pre-operative ultrasound was reviewed and recorded, this was done to allow for comparison between the two groups on the presence of gall bladder inflammation, which intern can complicate the operation and increase the operative duration and the risk of conversion to open. We also wanted to see if there was any association between diabetes and the stone size, and if there's any relation between the stone size and the rate of complications.

The Operative notes of all patients - groups 1 and 2 - were reviewed. We recorded the duration of the operation, and if there were any cases who required a conversion to open, and the reason behind it. We categorized the reasons for conversion to open into 3 categories: injury to the surrounding structures such as common bile duct (CBD) injury or bowel injury, the presence of uncontrolled bleeding, and difficult anatomy because of adhesions. We also recorded if there was any perforation of the gallbladder that has resulted in bile leak into the abdominal cavity, and the placement of drains. This was also done to compare between the two groups.

The progress notes were reviewed for immediate and early post-operative complications; that is within the 1st 24 hours post-operatively, and also for late post-operative complications by checking their files for any emergency room (ER) visits or re-admissions or from notes taken during the clinic follow up.

The immediate post-operative complications that we have collected were; post-operative fever, vomiting, cough, urine retention, chest pain, Deep Venous Thrombosis, and if there was any delay in resuming their diet postoperatively. Also we recorded the type of analgesics the patients were given and the frequency at which they were given analgesics postoperatively. This was done to see if there's any difference in pain control between diabetic and non-diabetic patients. The same parameters were also recorded in the 1st post-operative day. Those who have required the prolonged use of antibiotics were recorded.

Furthermore, we reviewed the files for any ER visits, readmissions, and clinic visits to detect any late complications as post cholecystectomy syndrome and incisional hernias. Histopathology results were also obtained.

The data we have collected was entered into the SPSS program for statistical analysis. The qualitative data were presented in the form of number and percentage. Chi-square test was done to compare between qualitative data. Yates correction was done when it is indicated. The quantitative data were presented in the form of mean, standard deviation and range. Student t-test was done to compare the quantitative data. Significance was considered when p value less than 0.05.

### 3. Results

A total of 112 patients underwent laparoscopic cholecystectomy for cholelithiasis. 18 patients were males (16.1%) and 94 were females (83.9%) with a ratio of 1:5.2. The mean ( $\pm$ SD) age was  $41.23 \pm 13.82$  years (range 15-75 years). Demographics and clinical data of all the patients that were included in our study are shown in table 1.

**TABLE 1** - Demographics and clinical data of all the patients who have undergone laparoscopic cholecystectomy that were included in our study.

	Number of patients (N)	Percentage %
<b>Age</b>		
<i>Mean <math>\pm</math> SD</i>	$41.23 \pm 13.82$	
<i>Range</i>	(15 – 75)	
<b>Gender</b>		
<i>Male</i>	18	16.1
<i>Female</i>	94	83.1
<b>Nationality</b>		
<i>Saudi</i>	66	58.9
<i>Non-Saudi</i>	46	41.1
<b>Diabetic</b>	18	16.1
<i>Type 1</i>	1	5.9
<i>Type 2</i>	17	14.3
<b>Non-Diabetic</b>	94	83.9
<b>Control of Diabetes</b>		
<i>Well controlled</i>	8	7.1
<i>Poorly controlled</i>	10	8.9
<b>Duration of Diabetes (years)</b>		
<i>Mean <math>\pm</math> SD</i>	$9 \pm 8.75$	
<i>Range</i>	(3 – 30)	
<b>Co-morbidities</b>		
<i>Hypertension</i>	11	9.8
<i>Hyperlipidemia</i>	3	2.7
<i>Hypothyroidism</i>	3	1.8
<i>Chronic Renal Failure</i>	1	0.9
<i>Asthma</i>	2	1.8
<i>Sickle Cell Anaemia</i>	1	0.9
<i>Multiple co-morbidities</i>	9	8.0
<b>History of previous abdominal operations</b>	11	9.8



The operation was performed as an elective procedure in 104 patients (92.9%) and as an emergency in 8 patients (7.1%).

Diabetics had a significantly higher rate of emergency admissions (22.2%) compared to non-diabetics (4.3%) with a *p* value of 0.022. Also, our results shows that emergency admissions were associated with higher rates of conversion to open (80%) compared to elective admissions (20%) with a *p* value of 0.00.

Out of 112 patients, 18 cases of them were diabetics (16.1%), while 94 patients (83.9 %) were not diabetics. Among the diabetic patients, 8 had well controlled diabetes, and 10 were poorly controlled (7.1% and 8.9%, respectively). The mean ( $\pm$ SD) duration of the diabetes was  $9 \pm 8.75$  years (range 3-30 years). Comorbidities found in our patients are shown in table 2.

**TABLE 2** – Comparison of Diabetics with non-diabetics regarding demographics, comorbidities and pre-operative evaluation

	Diabetics		Non- Diabetics		Significance – determined by <i>p</i> value <0.05
	<i>N</i>	%	<i>N</i>	%	
<b>DEMOGRAPHICS</b>					
<b>Gender</b>					1.000
<i>Males</i>	3	16.7	15	16	
<i>Females</i>	15	83.3	79	84	
<b>Nationality</b>					0.071
<i>Saudi</i>	7	38.9	35	37.2	
<i>Non-Saudi</i>	11	61.1	94	94	
<b>PRE-OPERATIVE EVALUATION OF DIABETICS VS. NON-DIABETICS</b>					
<b>Liver Function Tests</b>					
<i>Elevated AST</i>	7	38.9	15	16.7	<b>0.040</b>
<i>Elevated ALT</i>	2	11.1	18	20.1	0.303
<i>Elevated ALP</i>	4	22.2	15	16.7	3.393
<i>Elevated GGT</i>	4	22.2	19	21.1	1.567
<b>Pre-operative Ultrasound Diagnosis</b>					1.000
<i>Uncomplicated cholelithiasis</i>	17	94.4	71	93.4	
<i>Calcular cholecystitis</i>	1	5.6	5	6.6	
<b>Number of stones</b>					0.123
<i>Solitary stone</i>	7	41.2	18	23.7	
<i>Multiple stones</i>	10	58.8	58	76.3	
<b>Stone size - cm</b>					
<i>Mean <math>\pm</math> SD</i>	1.58 $\pm$ 0.74		1.29 $\pm$ 0.61		0.171
<b>Increased Gallbladder Wall thickness &gt; 4 mm</b>	4	22.2	19	23.8	0.581
<b>Type of admission</b>					<b>0.022</b>
<i>Elective admission</i>	14	77.8	90	95.7	
<i>Emergency admission</i>	4	22.2	4	4.3	
<b>Co-morbidities</b>					<b>0.003</b>
<i>Hypertension</i>	6	33.3	74	80.4	
<i>Hyperlipidemia</i>	0	0	3	3.3	
<i>Hypothyroidism</i>	1	5.6	2	2.2	
<i>Chronic Renal Failure</i>	0	0	1	1.1	
<i>Asthma</i>	1	5.6	1	1.1	
<i>Sickle Cell Anaemia</i>	0	0	1	1.1	
<i>Multiple co-morbidities</i>	---	---	---	---	
<b>History of previous abdominal operations</b>	3	17.6	14	82.4	0.267

**Pre-operative evaluation**

Results of the pre-operative assessment revealed a mean HbA1c ( $\pm$ SD) of  $8.45 \pm 1.73$  (range 6.5-11.7) in our diabetic patients. The mean pre-operative fasting plasma glucose level ( $\pm$ SD) was  $9.83 \pm 4.08$  mmol/l (range 5.7-18.0) and the mean random plasma glucose level ( $\pm$ SD) was  $9.10 \pm 5.41$  mmol/l (range 5.9-17.2).

Liver enzymes were also measured in all patients prior to laparoscopic cholecystectomy. AST was elevated in 22 patients (19.6%), elevated ALT in 20 patients (17.9%), elevated ALP in 19 patients (17.0%) and elevated GGT in 23 patients (20.5%). Elevated liver enzymes when compared between group 1 and group 2 showed a significant difference in the elevation of AST in diabetics (Group 1) compared to non-diabetics (Group 2), with a p value of 0.040. However, elevation in liver enzymes showed no significance in relation to the conversion to open cholecystectomy.

Preoperative abdominal ultrasound showed uncomplicated cholelithiasis in 88 patients and calculous cholecystitis in 6 patients (78.6 % and 5.4%, respectively). There was a significant difference in the rate of conversion to open in those with calculous cholecystitis compared to uncomplicated gallstone disease with a p value of 0.031. On the other hand there was no difference in the pre-operative ultrasound findings between diabetics and non-diabetics.

**Intraoperative course of laparoscopic cholecystectomy**

The mean ( $\pm$ SD) duration of operation was  $104.21 \pm 44.29$  min (range 37 - 270 min). There was no statistically significant difference in the mean duration of operation in diabetics ( $114.06 \pm 60.01$ ) compared to non-diabetics ( $102.30 \pm 40.688$ ). Table 3.

**TABLE 3** - Comparison between diabetic and non-diabetic patients in intraoperative and immediate post-operative course (<24 hours)

	Diabetics		Non- Diabetics		Significance – determined by <i>p</i> value <0.05
	<i>N</i>	%	<i>N</i>	%	
<b>INTRA-OPERATIVE COURSE OF DIABETICS VS. NON-DIABETICS</b>					
<b>Duration of operation(<i>min</i>)</b> <i>Mean <math>\pm</math> SD</i>	$114.06 \pm 60.01$		$102.30 \pm 40.688$		0.305
<b>Intra-operative bleeding</b>	2	11.1	1	1.1	0.068
<b>Intra-operative injury to CBD and surrounding organs</b>	---	---	---	---	
<b>Gallbladder perforation with intra-peritoneal bile leak</b>	5	27.8	11	12	0.135
<b>Drain placement</b>	3	16.7	3	3.2	0.053
<b>Intra-operative adhesions</b>	7	46.7	26	34.7	0.775
<b>Conversion to open</b>	3	16.7	2	2.1	<b>0.029</b>
<b>IMMEDIATE POST-OPERATIVE COURSE &lt;24h OF DIABETICS VS. NON-DIABETICS</b>					
<b>Fever</b>	3	16.7	5	5.4	0.119
<b>Vomiting</b>	0	0	1	1.1	0.838
<b>Cough</b>	1	5.6	1	1.1	0.299
<b>Chest pain</b>	0	0	2	2.2	0.701
<b>Shortness of breath - Need of oxygen mask</b>	2	11.1	2	2.2	0.122
<b>Post-operative pain</b>					0.155
<i>Mild – PRN analgesics</i>	4	22.2	18	19.4	
<i>Moderate – regular analgesics</i>	14	77.8	65	69.9	
<i>Severe - both</i>	0	0	10	10.8	
<b>Analgesia used</b>					
<i>Opiates for pain</i>	15	83.3	68	73.1	0.277

There were a total of 3 (2.7%) patients who had intraoperative bleeding of which 2 were diabetics and 1 non-diabetic (11.1% and 1.1%, respectively with a *p value* of 0.068), thus we found no statistically significant difference between diabetics and non-diabetics with respect to intraoperative bleeding. However, intraoperative bleeding was associated with a higher rate of conversion to open cholecystectomy with a *p value* of 0.005.

Gall bladder perforation with intraperitoneal bile leak occurred in 16 cases (14.3%), of which 5 were diabetics, and 11 non-diabetics (27.8% and 12% respectively with a *P- value* of 0.135). Gallbladder perforation however was also associated with a higher rate of conversion to open (*p value* 0.021).

In our series, there was no intraoperative injury to CBD or surrounding organs.

A total of 33 patients had intra-abdominal adhesions (29.5%) of which 7 were diabetic (46.7%) and 26 non-diabetics (34.7%) with a *P value* of

0.775. Also, those with adhesions did not have a significantly higher rate of conversion to open compared to those who did not (*p*=0.058).

Laparoscopic cholecystectomy was converted to open procedure in 5 patients (4.5%) of which 3 were diabetics (16.7%) and 2 non-diabetics (2.1%). This shows a statistically significant higher rate of conversion to open of diabetics compared to non-diabetics with a *p value* of 0.029.

#### Immediate post-operative course (<24 hours) and early post-operative course (>24 hours)

There was no statistically significant difference between diabetics and non-diabetics regarding immediate post-operative complication such as fever and pain control or early post-operative course with respect to resumption of normal diet, persistent jaundice and need of post-operative antibiotics (Table 3 and 4).

**TABLE 4** - Comparison between diabetic and non-diabetic patients in early post-operative (>24 hours) and late post-operative course

	Diabetics		Non- Diabetics		Significance – determined by <i>p value</i> <0.05
	<i>N</i>	%	<i>N</i>	%	
<b>EARLY POST-OPERATIVE COURSE &gt;24h OF DIABETICS VS. NON-DIABETICS</b>					
Diet not resumed > 24 hrs	2	11.1	1	1.1	0.068
Resumption of normal diet					0.118
<i>POD1</i>	15	83.3	89	95.7	
<i>POD2</i>	3	16.7	3	3.2	
<i>POD3</i>	0	0	1	1.1	
Delayed Mobilization >24hrs	1	5.6	1	1.1	0.299
Prolonged need of post-operative antibiotics > 24hrs	14	77.8	59	63.4	0.185
Jaundice persisting >24hrs	0	0	1	1.1	1.000
Length of hospital stay post-operatively (days)					
<i>Mean ± SD</i>	2.06 ± 1.60		1.43 ± 0.96		<b>0.029</b>
<b>LATE POST-OPERATIVE COURSE OF DIABETICS VS. NON-DIABETICS</b>					
Persistent pain	1	5.6	1	1.1	0.299
Persistent Jaundice	0	0	1	1.1	0.299
Port-site wound infection	1	5.6	1	1.1	0.162
Port-site incisional hernia	---	---	---	---	---
Post-cholecystectomy syndrome	---	---	---	---	---

#### Length of Hospital Stay

The mean length of post-operative hospital stay for the whole study population was 1.53 ±1.09 and ranged between 1-7 days. Diabetics had a significantly higher mean length of post-operative hospital stay (2.06 ±1.60) compared to non-diabetics (1.43 ±0.96) with a *p value* of 0.029.

#### Late post-operative course

Persistent post-operative pain was noted in 2 patients (1.8 %) of which 1 diabetic, and 1 non-diabetic (5.6 % and 1.1 %, respectively; *P- value* 0.299). Persistent jaundice occurred in only 1 patient from the non-diabetic group (1.1%) *p*=0.299. Port site wound infection occurred in 2 cases of which 1 was diabetic and 1 non-diabetic (5.6% and 1.1 %, respectively with a *P- value* 0.162). In our series,

there was neither port site incisional hernia nor post-cholecystectomy syndrome.

#### Histopathology diagnosis of excised gall bladder in diabetics versus non diabetics

Uncomplicated cholelithiasis was found in 16 cases (14.3%) of which 4 were diabetics and 12 non diabetics (22.2% and 12.9 % respectively). Acute calculous cholecystitis was diagnosed in 11 patients (9.8%) of which 2 were diabetics, and 9 non-diabetics (11.1% and 9.7% respectively), and chronic calculous cholecystitis in 83 cases (74.1%) of which 12 were diabetics and 71 non diabetic (66.7% and 76.3 %, respectively). Focal dysplasia was identified in one non-diabetic patient (1.1%). We had no patients who were found to have malignancy. There was no significant difference in histopathology results of diabetics compared to non-diabetics. However 60% of those who had a conversion to open had acute cholecystitis compared to 8% of those who did not have a conversion ( $p=0.029$ ).

#### Factors associated with conversion to open cholecystectomy (Table 5).

Higher mean age was associated with increased rate of conversion to open cholecystectomy. The mean age ( $\pm$ SD) of those who had a conversion to

open was  $58.6 \pm 11.67$  and the mean age of those who had no conversion was  $40.42 \pm 13.42$ . This shows a statistically significant difference with a  $p$  value of 0.004.

Males had a higher rate of conversion to open (60%) compared with females (40%),  $P=0.029$ .

Although Diabetics had a higher rate of conversion to open (60%) compared to non-diabetics (40%) with a  $p$  value of 0.029, the duration of diabetes mellitus, the level of HbA1c and fasting glucose level showed no significant effect on conversion to open procedure. The mean duration ( $\pm$ SD) of diabetes was equal in both who had a conversion and in those who did not ( $9.00 \pm 9.45$  years) giving a  $p$  value of 1.00. Patients who had a conversion to open had a mean HbA1c of  $7.70 \pm 1.82$ , and a mean fasting glucose level of  $11.13 \pm 6.24$  mmol/l, while those who did not have a conversion had a mean HbA1c level of  $8.55 \pm 1.82$  and a mean fasting glucose level of  $11.13 \pm 6.24$  mmol/l. ( $P$ - value 0.673 and 0.555 respectively) Table 5.

Pre-operative ultrasound diagnosis of calculous cholecystitis and post-operative histopathology diagnosis of acute calculous cholecystitis were associated with higher rates of conversion to open ( $p$  value= 0.031 and 0.029, respectively).

**TABLE 5**– Independent T-test done to assess factors associated with conversion to open cholecystectomy.

	Conversion to open	No conversion	Significance – determined by $p$ value <0.005
<b>Age</b> <i>Mean <math>\pm</math> SD</i>	$58.60 \pm 11.67$	$40.42 \pm 13.42$	<b>0.004</b>
<b>Duration of DM (y)</b> <i>Mean <math>\pm</math> SD</i>	$9.00 \pm 9.45$	$9.00 \pm 9.45$	1.000
<b>HbA1c</b> <i>Mean <math>\pm</math> SD</i>	$7.70 \pm 1.82$	$8.55 \pm 1.82$	0.673
<b>Fasting glucose</b> <i>Mean <math>\pm</math> SD</i>	$11.13 \pm 6.24$	$9.5 \pm 3.67$	0.555

#### 4. Discussion

Gallbladder disease is a worldwide concern. It affects more than 20 million people in the United States (2). In Saudi Arabia, the prevalence of gall stones and hence cholecystectomies have also been progressively rising over the years (3). This was linked to changes in dietary habits (3), and also was attributed to the introduction and availability of laparoscopic techniques (4). In 1997, a prospective study conducted in King Abdulaziz university hospital estimated the prevalence of asymptomatic gallstones among adult females. The results showed that 49% of the study population had gallstones. Also, it was significantly associated with old age, diabetes, and multiparity (5).

Several studies have shown the increased incidence of gall stone disease in diabetic patients (6,7). In 2004, **Pagliarulo et al.** found a significantly higher prevalence of gallstones in diabetics 24.8% compared with the general population 13.8 % (8). Some researchers suggest that this relationship is due to increased gallbladder volume (9), which in turn predisposes to bile stasis and hence stone formation. On the other hand, some researchers thought that diabetics are more prone to stone formation due to associated hyperlipidemia.

Due to its great outcome and low rates of complications compared to open cholecystectomy, Laparoscopic Cholecystectomy has become the gold standard treatment for gallstones for many years (10).

It has reduced the length of hospital stay and hence decreased costs.

Complications that may arise with laparoscopic cholecystectomy can be categorized into intra-operative and post-operative complications, which can be further subdivided into early and late complications.

Intra-operative complications such as bleeding, duct injury, bile leak, bowel perforation, if cannot be controlled, may necessitates the conversion to open cholecystectomy. Other reasons to convert to open procedure would be due to technical problems such as dense adhesions, inflammation, and difficult anatomy. Also, operative findings such as gangrenous cholecystitis or empyema may also require the conversion (11). Delayed post-operative complications of Laparoscopic Cholecystectomy are mainly Post-cholecystectomy syndrome, Intra-abdominal abscesses, and port-site incision hernias. Length of hospital stay usually used to assess the outcome and the complications of surgical procedures.

In 2000, **Lyass et al.** (12) studied several factors that may affect the outcome of lap chole. Their results showed that diabetes was one of the factors that significantly increased post-op morbidity, but did not increase the length of hospital stay after lap chole. Unlike our results that showed an increased length of hospitalization in diabetics post lap chole. Diabetics in our study had a significantly higher mean length of post-operative hospital stay ( $2.06 \pm 1.60$ ) compared to non-diabetics ( $1.43 \pm 0.96$ ) with a *p* value of 0.029.

In 2001, a study conducted in university of Erciyes, Turkey (13), found that operative and postoperative complications of lap chole in diabetics with symptomatic gallstones were significantly higher than non-diabetics. Their conversion to open rate was 7.1% in diabetics compared to 2.8% in non-diabetics. However, the comparison of operative time and length of hospital stay were not significant. Our results also showed a higher rate of conversion in diabetics compared to non-diabetics.

In 2006, a study conducted by Ibrahim *et al.* (14), in Singapore, found that the mere presence of diabetes does not appear to increase the risk of conversion to open, however they found an association between poorly controlled diabetes (elevated HbA1c >6) with an increased risk for converting to laparotomy. They thought that poorly controlled blood sugar levels leads to severe inflammation and hence severe adhesions distorting the anatomy as in patients with previous upper abdominal surgery. Also, patients who had a conversion were found to have significantly higher rates of complications postoperatively.

In our current study, we have had opposite results. The presence of diabetes in our patients increased the rate of conversion to open, however the levels of HbA1c and fasting glucose had no influence on the rate of conversion. On the other hand, we got similar results with respect to increased post-operative complications in those who have had a conversion.

In 2005, **Simopoulos et al.** (15), found a significant correlation between male genders, age above 60, previous upper abdominal surgery, and diabetes with increased rate of conversion to laparotomy. Our results showed similar risks associated with conversion to open.

In 2007, **Cheng et al.**, researchers from Taiwan (16), linked prolonged hospital stay after lap chole with the occurrence of major complication, specifically those associated with pulmonary disease in the elderly. They also concluded that no other comorbidity has direct impact on the duration of hospitalization.

In 2010, a study done in king Faisal University, Alhofuf, Saudi Arabia (17), found that there was no difference in the outcome of lap chole in diabetics compared to non- diabetics with respect to conversion to open and operative time. However, the length of hospital stay was found to be significantly different. Our results were similar in the length of hospital stay and operative duration, however, diabetics did have a higher rate of conversion to open.

In 2010, **Paajanen et al.**, from Kipio University hospital in Finland (18) studied the post-operative outcome of lap chole compared to open in diabetic patients. In their study, their results demonstrated that 16% of their diabetic patients required conversion to open compared with only 7% of their non-diabetic controls. They have also suggested that comorbidities of diabetes, especially renal disease, were associated with a higher risk of complications. In our study, we had no co-morbidity associated with conversion to open.

### Conclusion:

Up to our current state of knowledge, very few studies have evaluated the relationship of Diabetes and its pre-operative control (as measured by glucose levels and HbA1c) as a sole and independent risk factor for complications associated with lap chole. Furthermore, those studies have had conflicting results. And since both diabetes and gallstones are important health challenges in our country, we thought it was imperative to further assess this relationship, to provide our patients with better care and outcome.

In our study population, we found that diabetes is associated with higher rate of emergency admissions compared to non-diabetics ( $p=0.022$ ). Emergency admissions in turn had higher rates of conversion to open compared to elective admissions ( $p=0.00$ ). Diabetes was also associated with higher rates of conversion to open compared to non-diabetics ( $p=0.029$ ), however, the duration of diabetes and the measured levels of HbA1c and fasting plasma glucose did not appear to correlate with the rate of conversion.

Diabetics had a significantly higher mean length of post-operative hospital stay compared to non-diabetics ( $p=0.029$ ). The factors that were associated with higher risk of conversion to open were older age ( $p=0.004$ ), male gender ( $p=0.029$ ), diabetes ( $p=0.029$ ), and acute calcular cholecystitis.

We still however recommend a pre-operative control of blood glucose until we have a prospective randomized control trial comparing diabetic and non-diabetics patient going for laparoscopic cholecystectomy to know at which level of HbA1c or level of blood glucose should be controlled before surgery.

#### Disclosure of benefit:

The authors have no conflict of interest, and are not supported/funded by any Drug Company.

#### Corresponding author

Saleh M. Aldaqal

Department of Surgery, Faculty of Medicine, King Abdulaziz University,

Jeddah, Kingdom of Saudi Arabia

[sdaqal@yahoo.com](mailto:sdaqal@yahoo.com)

#### References

1. Al-Nozha, Diabetes mellitus in Saudi Arabia. *Saudi Med J*, 2004, 25(11): 1603-10
2. Evehart JE, Khare M, Hill M, Maurer KR. Prevalence and ethnic differences in gallbladder disease in the United States. *Gastroenterology*, 1999; 117:632
3. Tamimi T.M., Wosornu L., Al-Khozaim A., Abdul-Ghani A. Increased cholecystectomy rates in Saudi Arabia. *Lancet*, 1990, 336 (8725): 1235-1237.
4. Al-Mulhim, A.A., Al-Ali, A.A., Albar, A.A., Bahnassy, A.A., Abdelhadi, M., Wosornu, L., Tamimi, T.M. Increased rate of cholecystectomy after introduction of laparoscopic cholecystectomy in Saudi Arabia. *World Journal of Surgery*, 1999, 23 (5): 458-462.
5. Bakhotmah, M.A. Prevalence of cholelithiasis in a living Saudi adult female population (ultrasonic study). *Saudi Medical Journal*, 1997, 18 (5): 496-498
6. Marshall M. Lieber. The Incidence of Gallstones and Their Correlation with Other Diseases. *Ann Surg.*, 1952; 135(3): 394-405.
7. Chapman BA, Prevalence of gallbladder disease in diabetics mellitus. 1996. *Dig Dis Sci.*, 41:2222.
8. Pagliarulo M, Gallstone disease and related risk factors in a large cohort of diabetic patients. *Dig Liver Dis.*, 2004; 36(2):130-4.
9. Chapman BA, Gallbladder volume (comparison of diabetics and controls).1998. *Dig Dis Sci.*, 43:344-348.
10. Litwin DE, Cahan MA. Laparoscopic cholecystectomy. *Surg Clin North Am.*, 2008;88(6):1295-313.
11. Shea JA, Healey MJ, Berlin JA, Clarke JR, Malet PF, Staroscik RN, Schwartz JS, Williams SV. Mortality and complications associated with Laparoscopic Cholecystectomy. A Meta-analysis. *Ann Surg.*, 1996; 224(5): 609-20
12. Lyass S, Perry Y, Venturero M, Muggia-Sullam M, Eid A, Durst A, Reissman P. Laparoscopic cholecystectomy: what does affect the outcome? A retrospective multifactorial regression analysis. *Surg Endosc.*, 2000;14(7):661-5.
13. Bedirli A, Sözüer EM, Yüksel O, Yilmaz Z. Laparoscopic cholecystectomy for symptomatic gallstones in diabetic patients. *J Laparoendosc Adv Surg Tech A.*, 2001; 11(5):281-4
14. Ibrahim S, Hean TK, Ho LS, Ravintharan T, Chye TN, Chee CH. Risk factors for conversion to open surgery in patients undergoing laparoscopic cholecystectomy. *World J Surg.*, 2006; 30(9):1698-704.
15. Simopoulos C, Botaitis S, Polychronidis A, Tripsianis G, Karayiannakis AJ. Risk factors for conversion of laparoscopic cholecystectomy to open cholecystectomy. *Surg Endosc.*, 2005;19(7):905-9.
16. Cheng SP, Chang YC, Liu CL, Yang TL, Jeng KS, Lee JJ, Liu TP. Factors associated with prolonged stay after laparoscopic cholecystectomy in elderly patients. *Surg Endosc.*, 2008; 22(5):1283-9.
17. Al-Mulhim AR. The outcome of laparoscopic cholecystectomy in diabetic patients: a prospective study. *J Laparoendosc Adv Surg Tech A.*, 2010; 20(5):417-20.
18. Pajananen H, Suuronen S, Nordstrom P, Miettinen P, Niskanen L. Laparoscopic versus open cholecystectomy in diabetic patients and postoperative outcome. *Surg Endosc.*, 2011; 25(3):764-70.

2/2/2012

## Spiritual Well-Being and Mental Health among Malaysian Adolescents

Nurizan Yahaya<sup>1</sup>, Yadollah Abolfathi Momtaz<sup>2</sup>, Mumtazah Othman<sup>1</sup>, Norhasmah Sulaiman<sup>1</sup>, & Farhan Mat Arisah<sup>1</sup>

1-Department of Resource Management & Consumer Studies, Faculty of Human Ecology, Universiti Putra Malaysia, 43400 UPM, Serdang, Selangor, Malaysia

2-Institute of Gerontology, Universiti Putra Malaysia, 43400 UPM, Serdang, Selangor, Malaysia

**Background:** Adolescents are vulnerable to various mental health problems. The existing body of knowledge on the role of spirituality on adolescents' mental health status is limited and disjointed. The main aim of this study was to examine impact of spirituality on adolescents' mental health problems, after controlling for possible sociodemographic factors. **Method:** A total of 1190 Malaysian adolescents selected through a multistage proportional stratified random technique from the Federal Territory of Kuala Lumpur and Selangor state filled out questionnaires including the Spiritual Well-Being Scale, the General Health Questionnaire-28 (GHQ-28), and sociodemographic characteristics. A two step hierarchical multivariate logistic regression using SPSS software for Windows (SPSS Inc., Chicago, Ill., USA) was employed to test hypothesis. **Results:** Using the recommended cut-off point of 6 or more for the total GHQ-28, the prevalence rate of possible mental health problems was calculated 54.6% (CI 95%: 51.8 to 57.4 ). The findings from hierarchical multivariate logistic regression showed existential well-being (OR =0.42,  $p \leq .001$ , 95% CI: 0.32–0.54) and religious well-being (OR =0.63,  $p \leq .01$ , 95% CI: 0.47–0.85) were statistically associated with 58% and 37% lower odds of mental health problem, respectively, over and above sex, living arrangements of adolescents, parental education and household income. **Conclusion:** The present study found noticeable rates of mental health problems among Malaysian adolescents and pointed out the importance of spirituality as a resilience factor might help children to cope with physiologic, physical and psychological changes through adolescence, successfully.

[Nurizan Yahaya, Yadollah Abolfathi Momtaz, Mumtazah Othman, Norhasmah Sulaiman, & Farhan Mat Arisah. **Spiritual Well-Being and Mental Health among Malaysian Adolescents.** Life Science Journal. 2012;9(1):440-448] (ISSN:1097-8135). <http://www.lifesciencesite.com>. 65

**Key words:** Adolescence; Coping, Malaysia; Mental health; Spirituality

### Introduction

The word adolescence is derived from the Latin verb 'adolescere' that refers to grow into maturity [1]. Adolescence is characterized by critical physical and psychological changes [2]. It is a critical stage in the life cycle [3] that has also been viewed as a challenge and a delight. It "is a delight because there is great pleasure to be gained for adults in this stage of a young person's development. It is a challenge, however, because there are undoubtedly many difficulties and obstacles to be overcome if adults and teenagers are to get on well with each other"[4].

The high prevalence of mental health problems in adolescents has been noted by several studies [1, 5]. It is noted that 10% to 25% of adolescents experience severe mental distress during adolescence [6].

While mental health problems can affect anyone at any point in life due to several factors such as genetics or family history of a disorder, chemical imbalances in the brain, or psychosocial and environmental stressors, it is extremely common in the adolescent period and can lead to substance use, school dropout, antisocial behaviour, and

consequently decreasing quality of life in adulthood [7].

Recent longitudinal and cross-sectional studies show evidence that children and adolescents with mental health problems are at risk of disorder later in the life course [8], developing negative outcomes later in life [9], experiencing social stigma of mental illness [10], developing patterns of antisocial and violent behavior [11], lower educational achievement, decreased quality of life [12], unemployment or underemployment, lower social class in adulthood [13-15], abuse [16], disability [17], and increased suicide rates as the third leading cause of death among adolescents [12, 18, 19].

According to the Population and Housing Census 2000, the adolescent age group (10-19 years of age) constitutes about one-fifth of the total population of 23.3 million in Malaysia [20]. Results of previous studies show that rates of mental health problems among Malaysian adolescents are quite high. For example, the finding from a survey in Malaysia the prevalence rates for emotional problems and aggressiveness were reported 49% and 41%, respectively [21].

However, impact of religiosity and spirituality on the mental health of aging populations has been well investigated and usually a positive effect has been documented [22, 23], it has not well researched among adolescents and little available works also emerged disjointed and non-significant evidence for such associations. For example, results of a review study showed only 25% of the studies reviewed had a positive association between religiosity /spirituality and mental health [24]. In addition, only existential well-being not religious well being was found to be as a significant predictor of adolescents and youth mental health status [12, 25, 26].

A second shortcoming is that most of the research in the field of spirituality and adolescents' mental health has been conducted in the Western world, such as Christianity and Judaism, with more attention to Hinduism and Buddhism samples and other religions such as Islam has been ignored in research. The purposes of this study were:

1- To describe mental health status and spiritual well-being (existential and religious well-being) among Malaysian adolescents.

2- To examine protective effects of spirituality (existential and religious well-being) on the mental health, after controlling for sociodemographic factors.

### Materials and methods

Data for this study was obtained from a cross-sectional school survey entitled "Mental and Spiritual well-being among adolescents" conducted from 2009 to 2010. The survey employed a self group-administered questionnaire which was distributed to 1200 16-year old Malay Muslim students who were selected using a multistage proportional stratified random sampling procedure from the Federal Territory of Kuala Lumpur and Selangor state (representing one-fourth of the Malaysian population). The survey was carried out at two stages. Initially, a simple random sampling technique was employed to select schools from different districts. Finally, the survey questionnaires were group-administered to all fourth year secondary school students in the selected schools, resulting in a sample of 1200 respondents. All students were informed that their participation is entirely voluntary and their identity shall be entirely confidential. Of the 1200 questionnaires distributed 1190 were collected back. Since 10 questionnaires distributed weren't collected back, response rate was calculated 99%.

### Ethical approval

Ethical approval was obtained from the Ministry of Malaysian Education (No: KP (BPPDP) 603/5/JLD2 (178) - 25/02/2010).

### Data analysis

The prevalence of mental health problem was computed for the total sample as well as by sociodemographic factors. A series of Chi squares were used to determine if demographic differences were statistically significant. To examine spiritual well being as predictor of mental health, we conducted a hierarchical logistic regression. In the first block of predictors, we entered demographic variables (sex, parental education, household income, and birth order); in a second block we entered spiritual well being. All analyses were conducted using SPSS software for Windows (SPSS Inc., Chicago, Ill., USA). Missing observations were treated by the "pairwise" deletion method.

### Measurements

#### Mental health status

Mental health status was assessed using General Health Questionnaire-28 (GHQ-28) , which has previously been validated against ICD-10 psychiatric diagnoses among Malay culture [27] . This questionnaire contains four subscales, measuring somatic complaints, anxiety and insomnia, social dysfunction, and severe depression. The often-recommended GHQ scoring method (0-0-1-1) was used to compute the total score and subscales score. Lower scores indicate higher well-being and functioning, while higher scores indicate psychological distress. According to previous study in Malaysia, for this study score 6 or over was considered as poor mental health[28].

#### Spirituality

Spiritual well being was measured using the 12-item spiritual well-being scale (SWBS) [29, 30] as one of the most commonly used measures of spirituality. This spiritual scale has already been validated in Malaysian context [31]. This scale comprised of two dimensions namely religious well being and existential well being. Maselko and associates [32] citing Ellison[33] state that religious well-being subscale measures individual's relationship with God' or a higher power whereas existential well-being subscale measures person's perceptions of meaning and purpose in life. In this study, the word "God" was replaced by "Allah".

The overall score on the SWBS is obtained by summing all 12 items. Subscale scores are generated by summing scores of the 6 items on each subscale. The Religious Well-being subscale measures individual's relationship with God or a higher power.



The Existential Well-being subscale measures perceptions of life purpose and satisfaction. Each subscale has a scoring range of 6 to 24 with a higher score indicating higher religious and existential wellbeing. Religious and existential well being was classified into two categories (low: below mean and high: equal or greater than mean) according to their mean values.

### Demographic characteristics

Sociodemographic variables included sex, parental education, living arrangement of adolescents, and household income. Sex was coded as 0 for boys and 1 for girls. Parental education as a proxy for socioeconomic status [34] was measured using the highest level of education attained by the adolescent's parents. Students were asked to identify the highest level of education completed by both their parents (never attended school, primary school, secondary school (PMR), secondary school (SPM), University/ College). Parental education was then classified as low (never attended school and primary school) middle (secondary school including PMR and SPM) and high (University/ College). Household income was measured by asking students to report father's and mother's monthly income. According to average Malaysian household income [35], respondents were then classified into two categories including below RM 3500 and equal or above RM3500 to reflect low and high-income households, respectively.

### Results

Of the 1190 adolescents examined in this study, there are a relatively equal percentage of males (55%) and females (45%). In the present study, however, majority of the respondents (85%) were living with both their parents, fifteen percent were living in a single parent household or living without any parent. Table 1 presents descriptive statistic of sociodemographic factors and specific variables in the study. About 52% of the respondents reported their household income lower than average Malaysian household income.

Two of the 1190 respondents did not answer questions in the SWB Scale. Among the other 1188 respondents, the mean score reported for total spiritual well-being was 43.0 (SD =3.66, possible range 12-48). The mean religious well-being and existential well-being scores were calculated 22.7(SD=1.88) and 20.3(SD=2.62), respectively. The statistical results are summarized in Table 1. In present study alpha coefficients were calculated for the Spiritual Well-Being Scale, .74; Religious Well-Being Scale, .71; and Existential Well-Being Scale, .70. Furthermore, the two-factor structure of this

scale was supported using principal components factor analysis.

Mental health was measured by the GHQ-28. The mean values (standard deviation) and reliability results for the total GHQ-28 and its four subscales are shown in Table 1. The mean value reported for total GHQ-28 was 6.4 (SD=3.61). Cronbach's alpha was .82 for the whole test, and it ranged from .67 to .82 among the scales, with somatic symptoms and social dysfunction subscales showing lower value. In addition, results of factor analysis for the GHQ-28 showed that previously reported factor structure was fairly supported.

In accordance with the previous studies [27, 36, 37] using the recommended cut-off point of 6 or more for the total GHQ-28, the prevalence rate of possible mental health problem was calculated 54.6% (CI 95%: 51.8 to 57.4 ).

Sociodemographic characteristics of the respondents by mental health status are displayed in Table 2. The crude analysis revealed that mental health problem was significantly associated with sex ( $\chi^2=21.58$ ,  $p\leq.001$ ), living type ( $\chi^2=10.85$ ,  $p\leq.001$ ), parental education ( $\chi^2=9.30$ ,  $p\leq.01$ ), and household income ( $\chi^2=7.59$ ,  $p\leq.01$ ), where higher prevalence of mental health problems were related to female adolescents, lower parental education, and low household income. However, living with both parents was significantly associated to lower prevalence of mental health problems. Lastly, similar test was conducted to examine relationship between religious and existential well being with mental health problems.

The results revealed significant relationship between religious well being and mental health problems ( $\chi^2=14.94$ ,  $p\leq.001$ ) as well as existential well being and mental health problems ( $\chi^2=61.30$ ,  $p\leq.001$ ). As it can be seen from Table 2, the prevalence rates of mental health problems among respondents who reporting high levels of religious and existential well being were statistically lower than adolescents with low levels of religious and existential well being (50.9% vs. 63.1%) and (44.0% vs. 66.7%), respectively.

### Results of hierarchical multivariate logistic regression

In the last step, a 2-step hierarchical multivariate logistic regression was conducted to test protective effects of religious and existential well on the mental health problems with adjusting for sociodemographic variables (See Table 3). Results of first step indicated the variation in the prevalence of adolescents' mental health problems is significantly influenced by sex (OR =1.93,  $p\leq.001$ , 95% CI: 1.48–2.51), household income (OR =0.73,  $p\leq.05$ , 95% CI:

0.54–0.98), and living arrangements of the respondents (OR =1.90,  $p \leq .01$ , 95% CI: 1.23–2.94). In contrast, the main effect of adolescents' parental education was not significantly associated with mental health problems of adolescents at multivariate analysis.

Findings from second step revealed adolescents reporting high levels of religious and existential well-being had substantially lower risks of mental health problems, after controlling for sociodemographic factors. Compared to those with low levels of

existential well-being, being in the high levels of existential well-being was associated with a 58% reduction in the odds of mental health problem (OR =0.42,  $p \leq .001$ , 95% CI: 0.32–0.54). In addition, individuals in the high levels of religious well-being had a 37% lower odds of mental health problems compared to individuals reporting low level of religious well being (OR =0.63,  $p \leq .01$ , 95% CI: 0.47–0.85).

**Table 1.** Descriptive statistic of sociodemographic factors and specific variables in the study

Variable	n	%	Mean	SD	Cronbach's alpha
Sex					
Girls	656	55.1			
Boys	534	44.9			
Parental education	90	7.6			
Low education	518	44			
Middle education	570	48.4			
High education					
Living arrangements					
Living with both parents	1011	85			
Living with others	179	15			
Household income					
Below *RM 3500	528	52.4			
RM 3500 +	479	47.6			
Mental health status					
Somatic symptoms	1190		0.94	1.32	0.67
Anxiety and insomnia	1190		1.11	1.51	0.78
Social dysfunction	1190		3.85	1.93	0.67
Severe depression	1190		0.46	1.1	0.82
Total GHQ-28	1190		6.4	3.61	0.82
Spiritual well-being					
Religious well-being	1188		22.7	1.88	0.71
Existential well-being	1188		20.3	2.62	0.70
Total spiritual well-being	1188		43	3.66	0.74

\* Note: 1USD is equivalent to 3.1 RM (Ringgit Malaysia) at time of the data collection

**Table 2.** Frequency and distribution of mental health problems by spirituality and sociodemographic factors

Variable	Categories	n	%	CI 95%
Sex	Girls	398	60.7	56.9-64.3
	Boys	252	47.2	43.0-51.4
Parental education	Low education	33	63.3	27.4-47.0
	Middle education	219	57.7	38.1-46.6
	High education	284	49.8	45.7-53.9
Living type	Parents	532	52.6	49.5-55.7
	Others	118	65.9	58.7-72.5
Household income	below *RM 3500	307	58.1	53.9-62.3
	RM 3500 +	237	49.5	45.0-53.9
Religious well being	Low	224	63.1	58.0-68.0
	High	424	50.9	47.5-54.3
Existential well being	Low	367	66.7	62.7-70.5
	High	281	44.0	40.2-47.9

Table 3. Summary of hierarchical multivariate logistic regressions on mental health disorder: effect of Spiritual Well-Being controlling for sociodemographic variables

Variable	Categories	Reference categories	OR	95.0% CI for OR	
				OR	OR
Sex	Girls	Boys	1.93***	1.48	2.51
Living arrangement	Other	Living with both parents	1.90**	1.23	2.94
Household income	RM 3500	Below RM 3500	0.73*	0.54	0.98
Parental education	Middle	Low	0.85	0.50	1.44
	High		0.83	0.47	1.44
Religious well being	High	Low	0.63**	0.47	0.85
Existential well being	High	Low	0.42***	0.32	0.54

\*p≤.05 , \*\*p≤.01 , \*\*\*p≤.001

Hosmer and Lemeshow Test ( $\chi^2=7.03$ , df=8, p=.533)

### Discussion

Of the 1190 adolescents examined in the study 54.6% were at risk for possible mental health problems. This high prevalence rate of Malaysian adolescents' mental health problems observed in the present study is highly consistent with the results of previous studies among adolescents [1, 5, 6, 38-40]. For instance, the findings from a study among 2052 Korean adolescents showed that 74.3% of the respondents had frequently experienced interpersonal sensitivity, 56.9% for depression, 48.8% for anxiety and 41.6% for hostility. In Malaysian context, results of a recent study showed more than 50% of the Malaysian adolescents have high social stress and loneliness [39]. In addition, Eskin [40] investigated the psychological problems of a sample of 1381 Turkish adolescents using the General Health Questionnaire (GHQ-12). Author found that majority of the respondents (61.5%) had mental health problems. This high prevalence of mental health implies a need for effective mental health intervention programs for this vulnerable age group.

Female adolescents were more likely to have mental health problems compared to male. Sex differences in adolescents' mental health can be viewed as consistent with several studies indicating that female adolescents scored significantly higher level of mental health difficulties [39, 41, 42] than their male counterparts. In an attempt to explain sex differences in adolescents mental health , Pearson [43] stated several reasons. First, changes associated with puberty more negatively influenced young women than young men, consequently girls feel less confident about their bodies and their physical attractiveness. Second, poor body image experienced by young women may have an especially severe impact on their mental health. Finally, relationship between sex and mental health may be mediated by interpersonal relationships, because young women may be more reactive to stress within these relationships. Our result also supported the notion

that female sex may experience greater mental health problems than male at all stages of the life course from adolescence to adulthood [43].

With regard to living arrangement of adolescents, consistent with several previous studies [44-46] which have found crucial role of living arrangement towards adolescents' mental health , bivariate analysis as well as multivariate logistic regression showed a significant association between living arrangement and mental health problems, where adolescents living in a single parent household or living without any parent were more likely to have mental health problems. These findings highlight immense impact of living arrangements of adolescents on their lives.

The next well known significant factor related to mental health of adolescents was the income of their parents. This finding corroborates prior work [47-50] showing a link between parental socioeconomic status and mental health of adolescents. It has been noted that the effects of parental income on health of children is long lasting, because poor health in childhood is contributed to lower educational attainment, inferior labour market outcomes and worse health later in life [48].

The last sociodemographic factor which had a positive significant correlation with adolescents' mental health at a bivariate level, but was not independently predictor of adolescents' mental health at multivariate analysis was parental education. It can be postulated that some variables such as economic status may moderate effects of parental education on the adolescents' mental health. Our result would be consistent with a study among Australian children that showed parental education was not associated with having a high healthy lifestyle score [51].

As the main aim of this study was to examine impact of spirituality on mental health of adolescents, results of hierarchical multivariate logistic regression confirmed protective effects of religious and existential well being, after controlling for possible

sociodemographic factors. In comparison to what was already known in Malaysian context from a sample of 358 undergraduate students with a mean age 22.3 years, which found only existential well-being predicted psychological health [26], our study showed that adolescents' mental health status is significantly influenced by both religious well being and spiritual well being. Similar findings were found from a sample of 134 adolescents from a Midwestern suburban high school. The authors found that after controlling for demographics factors, existential well-being and religious well-being were significantly associated with depressive symptoms[12]. Our study also supported the findings from a systematic review of recent studies published between 1998 and 2004 which found higher levels of spirituality is associated with better mental health in adolescents[52].

Our results supported the findings from a few studies conducted in Islamic countries which examined effects of religiosity/spirituality on the physical and mental health of adolescents. For example, Abdel-Khalek [53] studied impact of religiosity on physical and mental health among a sample of 6339 adolescents ages ranged from 15 to 18 from Kuwait as an Islamic country. The findings of this study indicated that religiosity was significantly and positively associated with happiness, mental health, and physical health. Further study by Abdel-Khalek [53] explored the associations between religiosity, health, and psychopathology among two samples of 460 Kuwaiti and 274 American college students. Results indicated that religiosity was significantly and positively associated with ratings of physical health, mental health, and optimism. He also conducted another study to examine effects of religiosity on the mental health among a sample of 7211 Saudi adolescents. Results showed that religiosity was significantly correlated with psychological well being and depression. In other words, religious respondents were happier, healthier, and less depressed [54].

Since present study revealed that existential well being was associated with a 58% reduction in the odds of mental health problems compared to a 37% by religious well being, supports the evidence suggesting existential well-being is more important for mental health than religious well-being [12, 32, 52, 55, 56]. The existential well-being through several ways such as promoting hope, courage, resilience, coping abilities, and higher levels of self-esteem may contribute to better mental health [55, 57].

Our study was conducted among a sample from an Islamic society. The findings suggesting a significant association between spirituality and

mental health are also in consonance with the teachings of Al-Quran. In Islamic point of view, every human being is made up of two elements namely body and soul. Both of these components have basic needs. The soul component has some spiritual needs such as knowing Allah, belief in Him and worshipping Him. Meeting of these spiritual needs results in man's feeling of security and happiness[58]. Similarly, Hamzah and Maitafsir [59] citing Hanafi (1996) express those who live in consciousness of Allah will be safe and protected against sickness of the mind. In addition, the importance of spirituality to mental health has been mentioned in various verses of the holy Quran. For example, Allah (SWT) says in the holy Quran:

Prosperous is he who purified it and failed is he who buried it.

We send down (stage by stage) in the Quran that which is a healing and a mercy to those who believe: to the unjust it causes nothing but loss after loss.

"He is successful who purifies himself, and remembers the name of his Lord, and so prays

Those who believe, and whose hearts find comfort in the remembrance of Allah, is it not with the remembrance of Allah that hearts are satisfied.

Overall, results of this study showed a high prevalence rate of mental health problems among Malaysian adolescents. In addition, since during adolescence majority of the adolescents may experience storm and stress [60], the study highlighted the importance of spirituality as a resilience factor to help adolescents to pass this stage of life successfully.

### Implications

This study identified vulnerable adolescents who are experiencing poor mental health that need special attention from policy makers and those who working with adolescents. These vulnerable groups include female adolescents, those who are not living with both parents, and poor family. The results showing protective role of spirituality to prevent mental health problems in adolescence, it is also suggested that religious leaders as well as families should design and implement educational programs to strengthen spirituality among adolescents [58, 61]. Lastly, we suggest social workers, counselors and other mental health professionals working with adolescents integrate spirituality as an important resource into their therapeutic work for development and maintenance of adolescents' mental health. In addition, educational and practical programs to enhance the spiritual development of adolescent should be implemented in the family and school settings.

### Limitation s

Since this study was conducted in a cross-sectional design, longitudinal study is needed to clarify causal relationship between spirituality and mental health. Because exactly how spirituality positively influence adolescents' mental health is still unknown, further research is needed to clarify the processes between spirituality and mental health. As there is little known about ways to promoting spirituality among adolescents, it is suggested future studies focuses on the how to strengthen spirituality. Last limitation that should be acknowledged is related to the issue of ceiling effects of spirituality scale [62] which makes it difficult to distinguish between adolescents with high and low levels of spiritual well being and religious well being.

### Acknowledgement

This study was funded by Universiti Putra Malaysia through the Research Universiti Grant Scheme (RUGS- 91827).

**Corresponding Author:** Prof Dr Nurizan Yahaya, Department of Resource Management & Consumer Studies, Faculty of Human Ecology, Universiti Putra Malaysia  
43400 UPM, Serdang, Selangor, Malaysia E-mail: [nurizan@putra.upm.edu.my](mailto:nurizan@putra.upm.edu.my)

### References

1. Eskin, M., et al., *Prevalence of and factors related to depression in high school students*. Turkish Journal Of Psychiatry, 2008. **19**(4): p. 382-389.
2. Breidablik, H.J., E. Meland, and S. Lydersen, *Self-rated health during adolescence: stability and predictors of change (Young-HUNT study, Norway)*. The European Journal of Public Health, 2009. **19**(1): p. 73-78.
3. Boardman, J.D. and J.M. Saint Onge, *Neighborhoods and adolescent development*. Children, Youth and Environments, 2005. **15**(1): p. 138-164.
4. Coleman, J.C. and L.B. Hendry, *The nature of adolescence*. 2010, New York: Routledge.
5. Jorm, A.F., et al., *Mental health first aid training for high school teachers: a cluster randomized trial*. BMC psychiatry, 2010. **10**(1): p. 51.
6. Gilbert, A., et al., *Adolescent care*. Can Fam Physician, 2006. **52**: p. 1440-1441.
7. Martin, L. and A. Milot, *Assessing the Mental Health of Adolescents: A Guide for Out-of-School Time Program Practitioners*. Research-to-Results Brief. Publication# 2007-07. Child Trends, 2007: p. 5.
8. Maughan, B. and J. Kim-Cohen, *Continuities between childhood and adult life*. The British Journal of Psychiatry, 2005. **187**(4): p. 301-383.
9. Aviles, A., T. Anderson, and E. Davila, *Child and adolescent social-emotional development within the context of school*. Child and Adolescent Mental Health, 2006. **11**(1): p. 32-39.
10. Aisbett, D., et al., *Understanding barriers to mental health service utilization for adolescents in rural Australia*. Rural and Remote Health, 2007. **7**(2007): p. 1-10.
11. Steinberg, L., *Youth Violence: Do Parents and Families Make a Difference?* National Institute of Justice Journal, 2000. **243**: p. 31-38.
12. Cotton, S., et al., *The impact of adolescent spirituality on depressive symptoms and health risk behaviors*. Journal of Adolescent Health, 2005. **36**(6): p. 529.
13. McLeod, J.D. and K. Kaiser, *Childhood emotional and behavioral problems and educational attainment*. American Sociological Review, 2004. **69**(5): p. 636-658.
14. Breslau, J., et al., *Mental disorders and subsequent educational attainment in a US national sample*. Journal of psychiatric research, 2008. **42**(9): p. 708-716.
15. Needham, B.L., *Adolescent Depressive Symptomatology and Young Adult Educational Attainment: An Examination of Gender Differences*. Journal of Adolescent Health, 2009. **45**(2): p. 179-186.
16. Baxter, C., *Managing diversity and inequality in health care*. 2001, Edinburgh: Bailliere Tindall.
17. Shatkin, J.P. and M.L. Belfer, *The global absence of child and adolescent mental health policy*. Child and adolescent mental health, 2003. **9**(3): p. 104-108.
18. Page, R.M. and T.S. Page, *Promoting health and emotional well-being in your classroom*. 2010: Jones & Bartlett Learning.
19. World Health Organization, *Caring for Children and Adolescents with Mental Disorders: Setting WHO Directions*. 2003, Geneva.
20. Department of Statistics, *Yearbook of Statistics Malaysia*. 2008, Kuala Lumpur: Jabatan Perangka.
21. Hsien-Jin, T., W.P. Jun, and C.S. Kuan. *Malaysian Youth Mental Health and Well-Being Survey*. 2010; Available from: [http://www.ippbm.gov.my/v2/index.php?option=com\\_rubberdoc&view=category&id=40&Itemid=46&lang=bm](http://www.ippbm.gov.my/v2/index.php?option=com_rubberdoc&view=category&id=40&Itemid=46&lang=bm).

22. Momtaz, Y.A., et al., *Moderating effect of Islamic religiosity on the relationship between chronic medical conditions and psychological well-being among elderly Malays*. Psychogeriatrics, 2011. doi:10.1111/j.1479-8301.2011.00381.x.
23. Momtaz, Y.A., et al., *Moderating effect of religiosity on the relationship between social isolation and psychological well-being*. Mental Health, Religion & Culture, 2011. **14**(2): p. 141-156.
24. Dew, R., et al., *Religion/Spirituality and adolescent psychiatric symptoms: A review*. Child psychiatry and human development, 2008. **39**(4): p. 381-398.
25. Calicchia, J. and L. Graham, *Assessing the relationship between spirituality, life stressors, and social resources: Buffers of stress in graduate students*. North American Journal of Psychology, 2006. **8**(2): p. 307-320.
26. Imam, S.S., et al., *Spiritual and Psychological Health of Malaysian Youths*. Research in the Social Scientific Study of Religion, 2009. **20**: p. 85-101.
27. Fones, C., et al., *Studying the Mental Health of a Nation-A Preliminary Report on a Population Survey in Singapore*. Singapore medical journal, 1998. **39**: p. 251-255.
28. Zuraida, N.Z. and R. Parameswaran, *Prevalence of Depression among Patients with Headache in Kuala Lumpur, Malaysia*. Malaysian Journal of Psychiatry, 2007. **16**(2): p. 59-64.
29. Paloutzian, R.F. and C.W. Ellison, *Loneliness, spiritual well-being and the quality of life*. Loneliness: A sourcebook of current theory, research and therapy, 1982: p. 224-237.
30. Paloutzian, R.F. and C.W. Ellison, *Manual for the spiritual well-being scale*. 1991: Nyack, NY: Life Advances.
31. Imam, S.S., et al., *Malay version of spiritual well being scale: Is Malay Spiritual Well-being Scale a Psychometrically Sound Instrument?* The Journal of Behavioral Science, 2009. **4**(1): p. 72-83.
32. Maselko, J., S.E. Gilman, and S. Buka, *Religious service attendance and spiritual well-being are differentially associated with risk of major depression*. Psychological medicine, 2009. **39**(6): p. 1009-17.
33. Ellison, C., *Spiritual well-being: conceptualization and measurement*. Journal of Psychology and Theology, 1983. **11**: p. 330-340.
34. Hargittai, E., *Digital Na (t) ives? Variation in Internet Skills and Uses among Members of the "Net Generation"\**. Sociological Inquiry, 2010. **80**(1): p. 92-113.
35. Heng, H. and A. Guan, *Examining Malaysian household expenditure patterns on food-away-from-home*. Asian Journal of Agriculture and Development, 2007. **4**(1): p. 11-24.
36. Nagai, M., et al., *Poor mental health associated with job dissatisfaction among school teachers in Japan*. Journal of Occupational Health, 2007. **49**(6): p. 515-522.
37. Yusoff, M.S.B., *The Validity Of Two Malay Versions Of The General Health Questionnaire (GHQ) In Detecting Distressed Medical Students*. ASEAN Journal of Psychiatry, 2010. **11**(2): p. 1-8.
38. Kim, Y., *Correlation of mental health problems with psychological constructs in adolescence: final results from a 2-year study*. International journal of nursing studies, 2003. **40**(2): p. 115-124.
39. Yaacob, S.N., et al., *Loneliness, stress, self esteem and depression among Malaysian adolescents Siti Nor Yaacob Rumaya Juhari*. Journal of humanity, 2009. **14**: p. 85-95.
40. Eskin, M., *Adolescent Mental Health Problems and their relations with suicide behavior*. Klinik Psikiyatri Dergisi, 2000. **3**: p. 228-234.
41. Hishinuma, E.S., et al., *Differences in state-trait anxiety inventory scores for ethnically diverse adolescent in Hawaii*. Cultural Diverse Ethnic Minority Psychology, 2000. **6**(1): p. 73-83.
42. Andersson, H.W., et al., *The effects of individual factors and school environment on mental health and prejudiced attitudes among Norwegian adolescents*. Social psychiatry and psychiatric epidemiology, 2009. **45**(5): p. 569-577.
43. Pearson, J. *Gender Differences in Mental Health during Adolescence*. in annual meeting of the American Sociological Association. 2004. Hilton San Francisco & Renaissance Parc 55 Hotel, San Francisco, CA.
44. East, L., D. Jackson, and L. O'Brien, *Father absence and adolescent development: a review of the literature*. Journal of Child Health Care, 2006. **10**(4): p. 283-295.
45. Romansky, J.B., et al., *Factors related to psychiatric hospital readmission among children and adolescents in state custody*. Psychiatric Services, 2003. **54**(3): p. 356-362.
46. Rossow, I. and J. Rise, *Living arrangements and health behaviors in adolescence and young adulthood*. Health Education Research, 1993. **8**(4): p. 495-503.
47. Emerson, E., H. Graham, and C. Hatton, *Household income and health status in children*

- and adolescents in Britain*. The European Journal of Public Health, 2006. **16**(4): p. 354-360.
48. Doyle, O., C. Harmon, and I. Walker, *The impact of parental income and education on child health: Further evidence for England*. 2007.
  49. Hanson, M. and E. Chen, *Socioeconomic status and health behaviors in adolescence: a review of the literature*. Journal of behavioral medicine, 2007. **30**(3): p. 263-285.
  50. Elzubeir, M.A., K.E. Elzubeir, and M.E. Magzoub, *Stress and Coping Strategies among Arab Medical Students: Towards a Research Agenda*. Education for Health, 2010. **23**(1): p. 355.
  51. Gall, S.L., et al., *Intergenerational educational mobility is associated with cardiovascular disease risk behaviours in a cohort of young Australian adults: The Childhood Determinants of Adult Health(CDAH) Study*. BMC Public Health, 2010. **10**(1): p. 55.
  52. Wong, Y., L. Rew, and K. Slaikeu, *A systematic review of recent research on adolescent religiosity/spirituality and mental health*. Issues in Mental Health Nursing, 2006. **27**(2): p. 161-183.
  53. Abdel-Khalek, A.M., *Religiosity, happiness, health, and psychopathology in a probability sample of Muslim adolescents*. Mental Health, Religion & Culture, 2007. **10**(6): p. 571-583.
  54. Abdel-Khalek, A.M., *Religiosity, subjective well-being, and depression in Saudi children and adolescents*. Mental Health, Religion & Culture, 2009. **12**(8): p. 803 - 815.
  55. Cotton, S., et al., *Spiritual Well-Being and Mental Health Outcomes in Adolescents With or Without Inflammatory Bowel Disease*. Journal of Adolescent Health, 2009. **44**(5): p. 485-492.
  56. Edmondson, K.A., et al., *Spirituality Predicts Health and Cardiovascular Responses to Stress in Young Adult Women*. Journal of Religion and Health, 2005. **44**(2): p. 161-171.
  57. McDonnell Holstad, M.K., et al., *Factors Associated With Adherence to Antiretroviral Therapy*. Journal of the Association of Nurses in AIDS care, 2006. **17**(2): p. 4-15.
  58. Najaty, M.O. *The Concept of Mental Health in the Holy Quran and the Hadeeth*. 2010; Available from: <http://www.positive-action.net/al-yusra/Article%20Mental%20Health.htm>.
  59. Hamzah, M.D. and M.G. Maitafsir. *Transpersonal Psychotherapy: The Islamic Perspective*. 2007 [cited 2010 November 21]; Available from: <http://www.ifew.com>.
  60. Arnett, J., *Adolescent storm and stress, reconsidered*. American Psychologist, 1999. **54**(5): p. 317-326.
  61. Nash, S., *Promoting young people's spiritual well-being through informal education*. International Journal of Children s Spirituality, 2009. **14**(3): p. 235-247.
  62. King, J. and M. Crowther, *The measurement of religiosity and spirituality: Examples and issues from psychology*. Journal of Organizational Change Management, 2004. **17**(1): p. 83-101.

2/2/2012

## Evaluation of Water in Iran's Agriculture: A case study of Dashtenaz of Sari-Iran

Foad Eshghi<sup>1</sup>, Seyed-Ali Hosseini-Yekani<sup>2</sup>

<sup>1</sup>. MS Student, Department of Agricultural Economics, Tarbiat Modares University, Tehran, Iran

<sup>2</sup>. Assistant Professor, Department of Agricultural Economics, Sari Agricultural Sciences & Natural Resources University, Sari, Iran

[s.a.hosseiniyekani@gmail.com](mailto:s.a.hosseiniyekani@gmail.com)

**Abstract:** Today's world faces serious population increase. On the other hand, limited available resources for the man have resulted in an intensive competition and challenge between various economical sections and parts. One of the main and limiting factors of the Iranian agriculture section development is the water entry. Thus, optimized exploitation management which is achieved through establishment of balance between supply and demand of this scare commodity is the only solution. There are factors in agriculture which may not be clarified with a potential distribution, though there have been made several efforts to consider risk in agriculture economical models, but it will be possible to do so when there is established is compiled mathematical relation. On the other hand, in many of the third world countries, the limited capital and available agriculture entries may limit the farmers available options. Hence, it is required in these countries to apply precise analytical tools, so that not only the plans made as per the current realities may be chosen, but also the policies which consider the recommended social objectives may become possible. In these countries, the general problem of lack of statistical data requires that the programming models are designed so that they are mean in using such data. This study tries to use a modern method for Dasht Naz of Sari in different states from the respective productivity (here normal linear programming program) to achieve the shadow price of water. The water economical value (water shadow price) in summer is Rls 1030. This parameter for spring and autumn becomes zero. The Lindo6 software package has been used for this study.

[Foad eshghi, Seyed-Ali Hosseini-Yekani. **Evaluation of Water in Iran's Agriculture: A case study of Dashtenaz of Sari-Iran.** Life Science Journal. 2012;9(1):449-452] (ISSN:1097-8135). <http://www.lifesciencesite.com>. 66

**Keywords:** Water Evaluation; Agriculture; Linear Programming; Dashtenaz of Sari; Iran

### 1. Introduction

Any life species depends on water. Apart from that, water is of vital importance in industrial, agricultural, metabolism, etc. applications. Thus, lack of such substance is considered as a huge challenge for the mankind and also the natural scenes, electricity production, swimming, rowing, etc. also require water.

Today's world faces serious population increase. On the other hand, limited available resources for the man have resulted in a intensive competition and challenge between various economical sections and parts.

While the communities face the increased populations and also the water reserves seem not to be enough to provide the needs of such population, there are suggested a variety of solutions for such reserves, while two general methods of the same may be named as follows:

1. increased available reserves
2. increased productivity in using such reserves

Concerning the first case, due to limited reserves, the limited scope of such process is tangible, i.e. such process is impracticable to some extent. The second procedure seems more logical and it is likely that applying practical methods may

increase reserves exploitation productivity and take benefit maximum from the same (Keramatzadeh, 2006).

The highest water consumption in Iran is in the agriculture section. The water consumption figure in this sections is about 90% (Amirnejad, 2006). As Iran is placed in the dry and semi-dry region and the problems of lack of water indicate the requirement to more consideration of the issue of water and especially the water consumed in the agriculture section.

Also, whereas Iran is located in the dry and semi-dry region, lack of the water required for irrigation intensifies considering high population growth, development of economical activities, improvement of public living level, increased public tendent towards welfare, etc.

By increasing the demand as well as the heavy water exploitation costs and making the same available, the water reserves management shall seem quite important. By water demand management we mean establishment the balance between the fixed economical water supply/demand. Whereas water economical water means the available water with certain quality, in certain time and location for certain consumption, but its physical supply is always



limited. Thus, in order to establish the balance, the water economical demand side which is related to the level of benefit or appropriateness of the water consumer shall be emphasized. In establishing the balance between the water supply/demand such as any other goods and substance, the respective price or value plays a major role. In case such price is determined correctly, then it is expected that the current issues in water management are rectified (Gibbons, 1987).

Whereas the study region subject hereto is Sari Dashtenaz region, water assignment to the products with higher economical value and manner of its optimized assignment in different reasons in the way that the optimized cultivation model in the aforementioned region is achieved shall be the purpose of this study.

This study, which is based on water resources demand management, tries to estimate the water economical value in Dashtenaz of Sari region, so that by achieving available water resources economical management, the dissipation of this valuable entry and its optimized allocation are made possible. One of the common methods to determine the water shadow price is using the linear programming technique. Heady et al. 1973, used the linear programming technique to estimate 51 west US regions agriculture water demand and optimized corps distribution. The results of this study indicate that water final value have been zero in many regions and thus, the scholars consider the water price increase on water demand for corps cultivation as different in different regions. (Chaudhry. & Young, 1989) used the linear programming model to evaluate the Pakistani Punjab Province agriculture water and concluded that the answers of the linear programming method almost indicates the agriculture water final value and the price of the same depends on available water. in Colorado, (Houk.& Taylor,2000) categorized agriculture in five types and used the linear programming method to find the water price at each region for alfalfa cultivation. The results of this study show that the shallow waters shadow price is between 4.38~ 15.44 USD (Acre-Ft). (Abubakr.et al.,2009) used the linear programming and compiled the optimized cultivation model for the four regions of Helfa, Dangoula, Oldba and Moraveh in northern Sudanese province for 2003-2004 agricultural year. The results indicate that the farmers net income under optimized cultivation will increase with respect to the current conditions for 73.3%, 73%, 49.4% and 121%. Also, wheat in commercial production for Dangoula region may be increased up to 4.04 tons/hectare.

## 2. Material and Methods

There are a variety of methods to estimate the water shadow price. In this study the simple linear programming method has been used. the linear programming model mathematical relation may be

$$\text{expressed as follows: } \max z = \sum_{j=1}^n c_j x_j \quad (1)$$

$$s.t : \sum_{j=1}^n c_{ij} x_j \leq b_i \quad \text{for } i=1,2,3,\dots,m \quad (2)$$

$$x_j \geq 0 \quad j=1,2,3,\dots,n \quad (3)$$

In the aforementioned model, the relations (1), (2) indicate the objective function and constraints and relation (3) indicates the non-negative constraint nature of the activities.

The variable of this model shall be defined as follows:

X<sub>j</sub>: indicates the available various cultivated and garden products cultivation activities in the region

C<sub>j</sub>: indicates the net productivity of various corps which may be cultivated in the region.

Z: indicates the planned productivity and gross profit of the farmers of each region

B<sub>i</sub>: i<sup>th</sup> reserve contents of the region

C<sub>ij</sub>: technical factors, which indicates the i<sup>th</sup> substance content required to produce each unit of the j<sup>th</sup> product.

The main activities made in the region include: wheat, colza, grained corn, fodder corn, soybean and rice, while i variable associated to the aforementioned activities shall be as follows:

Soybean i=1, grained corn i=2, rice i=3, fodder corn i=4, wheat i=5, colza i=6, and j is the variable related to spring, summer and autumn, during which the company cultivates the corps, so that spring j=1, for summer j=2, and autumn j=3.

### Objective Function

The objective function is designed to maximize the net income, which is defined as follows:

$$\text{Max } \sum_{i=1}^6 \sum_{j=1}^3 c_{ij} x_{ij} \quad i \neq j \quad (4)$$

### Model Constraints

Whereas Dashtenaz Sari Cultivation and Industry requires to assign certain area of land for the activities of each season, we shall consider certain constraints for each of the seasons:

s.t :

$$\sum_{j=1}^n a_{ij} X_{ij} \leq b_j \quad (5)$$

Spring  $j=1$ , summer  $j=2$ , autumn  $j=3$ ; the Lindo6 software package has been used in this study.

### 3. Results and discussions

Table (1) indicates the current level of activities in the cultivation and industry, under which the total income of the cultivation and industry shall be Rls 25596120268.

**Table 1:** activities current level in calibrated model

Product	Variable	Quantity (hectares)
Soybean	X11	667.45
Grained corn	X21	602.52
Rice	X32	568.68
Fodder corn	X42	329.52
Wheat	X53	1106.66
Colza	X63	1127.33

Table (2) indicates the activities optimized level in cultivation and industry. In such conditions the total income of the cultivation and industry shall be increased to Rls 38502270000. Comparing these two situations indicates the areas under cultivation of soybean, maize, and wheat and the increased area under cultivation of corn, sweet-corn and colza in the optimized model in comparison to the current situation. Also, the income shall be increased for about 50%.

**Table 2:** activities optimized level (in hectares)

Product	Variable	Quantity (hectares)
Soybean	X11	819
Grained corn	X21	399
Rice	X32	179
Fodder corn	X42	745
Wheat	X53	1234
Colza	X63	553

The first two columns values of table (3) indicate a range of numbers between two upper and lower constraints (Allowable Increase and allowable Decrease figures), between which the activities (decision variables) or in other words the optimized answers shall be identical.

Due to taking benefit from the public donations as well as being located in one of the regions with the high raining average, Dashtenaz Cultivation and Industry faces excessive inventory for most of its required entries; in other words, in most of the entries the same faces with wasted

reserves. In the other hand, certain corps cultivation appears as a limit for different seasons.

**Table 3:** allowable Increase and allowable decrease figures in objective function factors (in Rls1,000)

Variable	Current Coefficient	Allowable Increase	Allowable Decrease
X11	1891.01	303	738
X21	2194.33	1407	303
X32	29482.9	83194	13839
X42	6016.75	5322	4442
X53	7216.14	933	3956
X63	8149.08	9891	932

One of the targets of this study is to compile the optimized cultivation model for cultivation and industry. Due to the results of the current cultivation model study, the cultivation in Sari Dashtenaz Cultivation and Industry is not optimized and in case of optimization, the company income may be increased. This study shall consider the seasonal limitations for the given model. Such limitation is arisen as the Dashtenaz Cultivation and Industry shall cultivate soybean and corn in spring, rice and maize in summer, and wheat and colza in autumn. Thus, this study gives a unique cultivation model for each of the aforementioned cultivations. Based on the results of the linear programming technique in case of using the optimized cultivation model, the company shall face highly increased income. Thus, in case the soybean, maize, and wheat cultivation areas are decreased for 18.5, 55 and 10.3%, and also in case the corn, rice and colza cultivated areas increased for 51, 210 and 103%, then the company's income shall increase about 50%. Thus, the cultivation model to be optimum is refused.

### 4. Summary and Concluding Remarks

1. Using optimized cultivation model results in an increase of about 50% in the company's net income. Thus, it is suggested that the company directors change the cultivation model and approach the optimized cultivation model.

2. The results indicate that water in summer season one of the most important production factors, during which notwithstanding the high rainy nature of the region, the company faces lack of water, which also shows that that the company's income may be increased by water reserves optimized management.

3. The water shadow price in summer is quite higher than the than the received water prices. Thus, increasing the water prices and approaching the same to the level of the shadow price will result in assignment of this important substance, and avoids water wasting.

4. Apart from water, the spring land, summer land, summer labor, and spring machinery will face lacking in the company, and the directors shall provide the company with increased income through land lease or purchase, machinery supply and hiring more labor.

5. Using the optimized cultivation model at the company by the directors will result in increased employment and eventually increased income of the company.

#### **Corresponding Author:**

Dr. Seyed-Ali Hosseini-Yekani  
Department of Agricultural Economics  
Sari Agricultural Sciences & Natural Resources  
University, Sari, Iran  
E-mail: [s.a.hosseiniyekani@gmail.com](mailto:s.a.hosseiniyekani@gmail.com)

#### **References**

1. Abubakr, I.S., El-Houri, A. and Babiker, I. 2009. Optimum winter cropping pattern in the northern state, Sudan. *Agricultural Economics*, 10:77-86.
2. Amirnejad, H. 2007. *Natural Resources Economics*, 109-128.
3. Chaudhry, M.A., and Young, R.A. 1989. Valuing irrigation water in Panjab province, Pakistan: A linear programming approach, *Water Resources Bulletin*, 25(5), 1055-1061.
4. Gibbons, D.C. 1987. *The economic value of water. Resources of the future, inc.*, Washington D.C., USA.
5. Keramatzadeh, A., Chizari, A.H., and Balali, H. 2005. Shirvan Barzo Dam: A Case Study. *Optimal Allocation of Water and Priority of Different Region in its Usage*, 17-34.
6. Heady, E.O., Madsen, H.C., Nicole, K.J., and Hargrove, S.H. 1973.
7. Houk, E., and G. TayloR. 2000. Valuing the characteristics of irrigation water in the platte, *Western Agricultural Economics Association Annual Meeting (On-line)*, 29. Available on the WWW: [url:http:// agecon.lib.umn](http://agecon.lib.umn).
8. Soltani, G.R., Zibaei, M. and Babiker, AA. 1999. *Application Of Mathematical Programming In Agriculture*.
9. Souri, A., and Ebrahimi, M. 2006. *Natural Resources And Enviromental Economics*, 157-172.

2/6/2012

## The Muscular Function for Human Knee Movement Revealed from Electromyography: A Preliminary Study

Y.-P. Sun<sup>1\*</sup>, K.-T. Yen<sup>1</sup>, H.-K. Kung<sup>1</sup>, Y.-C. Tsai<sup>1</sup>, K.-C. Lu<sup>1</sup>, C. M. Du<sup>1</sup>, Y. C. Liang<sup>2</sup>

<sup>1</sup>Department of Mechanical Engineering, Cheng Shiu University, TAIWAN, ROC

<sup>2</sup>Department of Aeronautics and Astronautics, R.O.C. Air Force Academy, TAIWAN, ROC

\*Corresponding author, E-mail: ypsun@csu.edu.tw

**Abstract:** The electromyography (EMG) of a male teenager performing isokinetic exercise is conducted to realize the characteristics of femoral muscles in human knee movement. The raw EMG data of rectus femoris muscle and biceps femoris muscle are full-wave rectified to demonstrate the electromechanical delay that ranges from 50 to 100 ms. The mean of biceps femoris EMG in isokinetics knee flexion is approximately 3-4 times as much as that of rectus femoris EMG in isokinetics knee extension. The rectified EMG signals are smoothed by using moving average method to receive a linear envelope that outlines the mean trend of EMG signals. It gives a clear perspective to observe the relation between the micro-scale EMG signal and the macro-scale kinetic data. This paper presents an important basis to establish a mechanical model of muscle for human knee movement.

[Y.-P. Sun, K.-T. Yen, H.-K. Kung, Y.-C. Tsai, K.-C. Lu, C. M. Du, Y. C. Liang. **The Muscular Function for Human Knee Movement Revealed from Electromyography: A Preliminary Study.** Life Science Journal. 2012;9(1):453-456] (ISSN:1097-8135). <http://www.lifesciencesite.com>. 67

**Keywords** electromyography, isokinetic exercise, rectus femoris, biceps femoris, moving average

### 1. Introduction

Electromyography (EMG) represents the electrical activity of muscle. The study of muscle activity from EMG provides valuable information for the dynamics and control of human movement. The EMG of the muscles during a particular task can indicate which muscles are active and when the muscles initiate and cease. More importantly, the qualitative and quantitative assessments can be obtained from EMG and give an important understanding of the muscular function under tasks and exercises<sup>[1]</sup>.

Piper<sup>[2]</sup> was the first investigator to study EMG signals. Basmajian and De Luca<sup>[3]</sup> wrote a milestone reference book to explore the interdisciplinary potential for EMG. Merletti and Parker<sup>[4]</sup> bridged a gap between engineering and physiology. Lloyd and Besier<sup>[5]</sup> provided an EMG-driven musculoskeletal model to estimate muscle forces and knee joint moments. Kiguchi and Imada<sup>[6]</sup> presented a muscle-model-oriented EMG-based control method to activate a lower-limb power-assist robot according to the users motion intention. Sun et al.<sup>[7]</sup> studied the effects of aging on knee joint movement by comparing the rectus femoris and biceps femoris EMG of different ages in isokinetic and isometric exercise. Yen, Tsai and Chang<sup>[8]</sup> used integral EMG to investigate muscular performance of applying different vibration and plyometric training.

In this paper, an isokinetic exercise for knee movement is performed by an individual subject. The EMG data of rectus femoris muscle and biceps femoris muscle are recorded. For the stand alone EMG is difficult to interpret, the kinetic data including the angle, angular velocity, and torque of knee are recorded

too. By rectification of the raw EMG signal, the electromechanical delay between the onset of muscle and the onset of knee movement is clearly shown. The mean of the rectified EMG data during knee extension and flexion in isokinetic exercise is presented. Finally a linear envelope is determined by moving average method to produce a smooth curve that gives an important understanding of muscle activity for the control of knee movement.

### 2. Method

The subject is a healthy male teenager, age 15, height 171.1 cm, and weight 65.77 kg. An isokinetic exercise for knee extension and flexion is performed by the subject on the Biodex isokinetic dynamometer at a controlled angular velocity with varying resistance. The functions of isokinetic dynamometer is to isolate a lower limb, stabilize the adjacent segments, and control the speed of knee joint movement, typically in this study at 60°/s.

The muscular actions are considered to determine which muscle to be observed. The quadriceps femoris muscle group, the producer of knee extension, consists of the rectus femoris, vastus lateralis, and vastus medialis. Its antagonistic muscle group, hamstrings, contributing to knee flexion consists of the biceps femoris, and semimembranosus, and semitendinosus. Both the rectus femoris producing knee extension and the biceps femoris producing knee flexion are selected for the observation of their EMG signals during knee isokinetic movement.

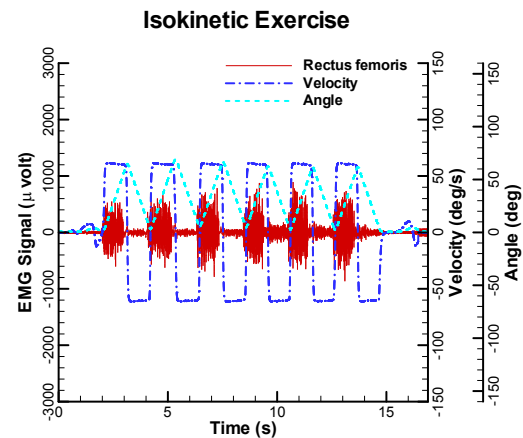
There are two ways to acquire EMG signal: needle and surface EMG techniques. The needle EMG technique uses fine wire electrodes by inserting the

needle into the muscle tissue; however, the surface EMG technique uses the non-invasive skin surface electrode. The former is more suitable for diagnostic applications; the latter has major applications in biofeedback, prosthesis control, and movement analysis. Both are complementary and important tools for physiological research<sup>[4]</sup>. This study is focused on surface EMG. It needs surface electrodes, amplification, and acquisition to record the EMG signal. The NORAXON TeleMyo 2400T G2 is used to acquire data which includes surface EMG electrode leads with pre-amplifiers (common mode rejection ratio > 100 dB, input range  $\pm 3.5$  mV, gain 500), hardware filter (all surface EMG electrode leads have 1<sup>st</sup> order high pass filters set to 10 Hz, all channels have low pass anti-alias filters set to 1500 Hz), and transmitter data acquisition system (16-bit resolution, sampling frequency 1500 Hz). The measurement setup, reports generation, and the important signal check procedures including the proof of the EMG signal validity and inspection of the raw EMG-baseline quality are completed in the software environment NORAXON MyoResearch XP<sup>[9-11]</sup>.

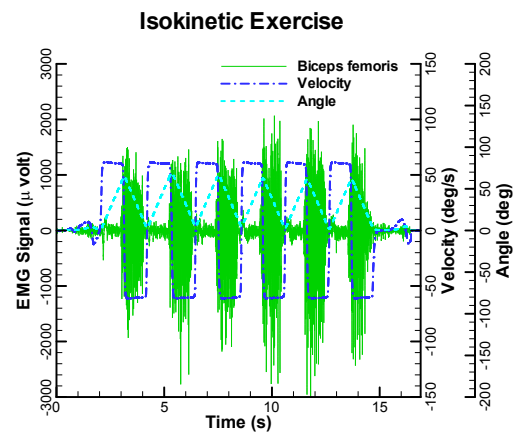
Finally the MathWorks, Inc., MATLAB is applied to signal processing such as full-wave rectification, mean, and moving average smoothing and the Amtec Engineering, Inc., Tecplot is applied to data visualization.

### 3. Results and Discussion

Fig. 1 presents a global view of the raw EMG of rectus femoris and biceps femoris associated with velocity and angle in isokinetic exercise. In every cycle of knee extension-flexion, the period of positive angular velocity represents extension at the knee and the period of negative angular velocity represents flexion at the knee. A muscle action potential produced by nervous contraction command results in a burst of EMG signal. As shown in Fig. 1 (a), the rectus femoris is activated during knee extension and relaxed during knee flexion. In contrast, as shown in Fig. 1 (b), the biceps femoris is activated during knee flexion and relaxed during knee extension. The EMG clearly indicates muscle activity. The full-wave rectification of EMG signal is shown in Fig. 2 and 3. Rectification is taking the absolute value of the raw EMG signal. The “on-off” characteristic can be derived by setting a threshold of rectified EMG. Let the threshold be 200  $\mu$  volt, a short but distinct delay between the onset of rectified EMG signal and the onset of velocity is observed from Fig. 2 and 3. This is referred to as the electromechanical delay (EMD)<sup>[1]</sup>, indicating the transport delay between neural signal input to the muscle and kinematic signal output of the muscle. As shown in Fig. 2 and 3 the EMDs for rectus femoris and biceps femoris are within 100 ms.

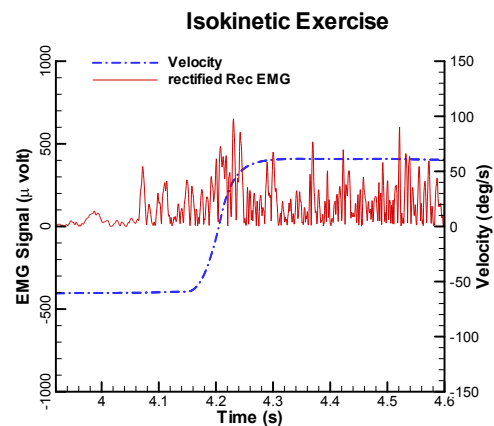


(a) Rectus femoris EMG

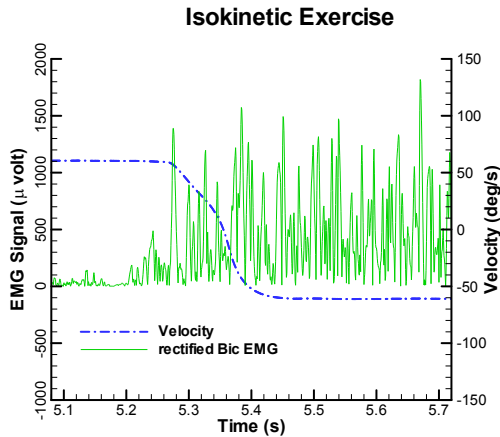


(b) Biceps femoris EMG

**Figure 1.** The raw EMG data of rectus femoris muscle and biceps femoris muscle

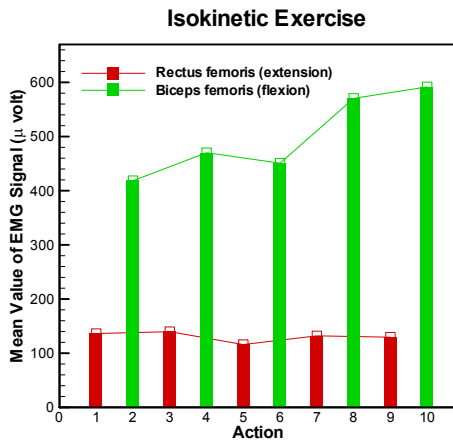


**Figure 2.** The electromechanical delay in rectus femoris EMG



**Figure 3.** The electromechanical delay in biceps femoris EMG

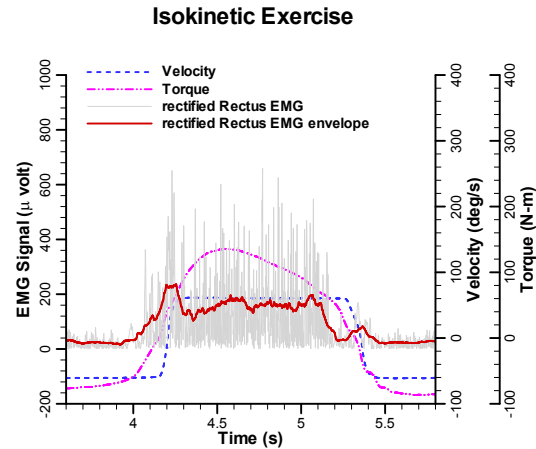
Fig. 4 presents the mean of rectified EMG signal in isokinetic exercise. The results show that the rectus femoris and biceps femoris are activated by turns. There is no co-activation in knee isokinetic movement. It suggests that the rectus femoris and biceps femoris are sophisticated cooperated with each other to perform the knee extension and flexion smoothly. If a quantitative amplitude is targeted, the mean of rectified biceps femoris EMG signal is as much as 3 to 4 times larger than that of rectified rectus femoris EMG signal.



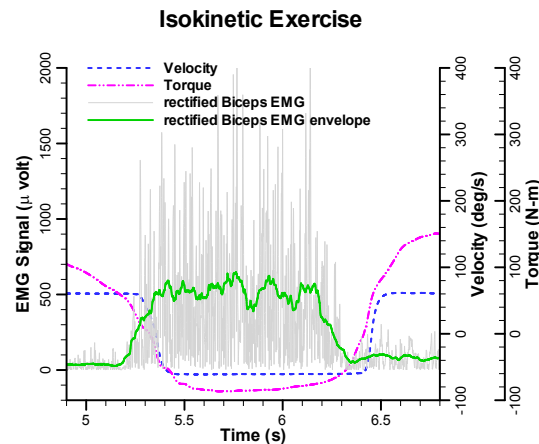
**Figure 4.** The mean of rectified EMG signal in isokinetic exercise

Fig. 5 and 6 presents the linear envelopes of rectified rectus femoris EMG signal and biceps femoris EMG signal by using moving average method at 100 ms in isokinetic exercise. As the pattern of EMG is of random nature, the EMG cannot be reproduced by a specific shape. In order to increase reliability and validity of findings from EMG signal, the smoothing method is

applied to outline the mean trend of EMG signal. The resulting linear envelope provides clear curve characteristics that would be helpful to explore the relationship between kinetics and EMG. In Fig. 5 and 6 the the linear envelopes of EMG signals and torques curves appears a close relation to be revealed.



**Figure 5.** The linear envelope of rectified rectus EMG signal by moving average smoothing



**Figure 6.** The linear envelope of rectified biceps EMG signal by moving average smoothing

#### 4. Conclusion

This paper presents a preliminary study of knee isokinetic movement from EMG signal. The EMG indicates that the rectus femoris is active in knee extension and the biceps femoris is active in knee flexion. The mean of biceps femoris EMG is about 3 times than that of rectus femoris EMG. The electromechanical delay between rectified EMG signal and kinematic response is observed, ranging from 50 to 100 ms. Finally, The linear envelope by applying moving average method to the rectified EMG signal is obtained. It would be useful for the determination of the relationship between human body kinetics and EMG.

### Acknowledgements

The authors would like to thank the National Science Council, Taiwan, R.O.C., for financial support under grant No: NSC 99-2632-E-230-001-MY3.

### References

1. Hamill, J. and Knutzen, K. M. Biomechanical basis of human movement, 2<sup>nd</sup> Ed. Lippincott Williams & Wilkins, 2003
2. Piper, H. Electrophysiologie menschlicher muskeln. Berlin: Springer Verlag, 1912.
3. Basmajian, J. and De Luca, C. J. Muscles alive: their function revealed by electromyography, 5<sup>th</sup> Ed. Williams and Wilkins, 1985
4. Merletti, R. and Parker, P. Electromyography: physiology, engineering, and noninvasive applications. IEEE Press, 2004
5. Lloyd, D. G. and Besier, T. F. An EMG-driven musculoskeletal model to estimate muscle forces and knee joint moments in VIVO. Journal of Biomechanics, 2003, 36:765-776
6. Kiguchi, K. and Imada, Y. EMG-based control for lower-limb power-assist exoskeletons. Proceedings of the IEEE Workshop on Robotic Intelligence in Informationally Structured Space, Nashville, TN, USA, 2009, 19-24
7. Sun, Y.-P., Yen, K.-T., Lu, K.-C., Du, C.-M. and Liang, Y.-C. An investigation of age-related effects on knee joint from electromyography signal (in Chinese). Proceedings of the Annual Symposium on Biomedical Engineering and Technology, Tainan, Taiwan, 2011
8. Yen, K.-T., Tsai, C.-B., Chang, K.-Y. Effects of vibration training combined with plyometric training on muscular performance and electromyography. Life Science Journal, 2010, 7(1):78-82
9. TeleMyo 2400T G2 transmitter user manual. NORAXON U.S.A., Inc., 2007
10. MyoResearch XP main manual. NORAXON U.S.A., Inc., 2004
11. Konrad, P. The ABC of EMG. NORAXON U.S.A., Inc., 2005.

2/3/2012

## Applications of Thermal Spray Coating in Artificial Knee Joints

J.-C. Hsiung\* H.-K. Kung\* H.-S. Chen\* Kuan-Yu Chang\*\*

\*Department of Mechanical Engineering, Cheng Shiu University, Taiwan, ROC

\*\*Mackay Memorial Hospital, Taitung Branch, Taiwan, ROC

\*E-mail: jchsiung@csu.edu.tw

**Abstract:** With remarkable medical advances, aging population makes the artificial knee joint replacement increasingly popular, and the quality of total knee replacement depends on materials selection and the application of surface coating. Titanium alloys have been widely used as artificial knee joint material due to their specific properties such as low density, toxicity and excellent corrosion resistance and biocompatibility. Thermal spray coating technology is used worldwide in many industrial applications, but the application of thermal spray biocompatible coatings on the titanium alloy surface in the biomedical field as to improve the knee's functions is a relatively new area. The purpose of this study was to make a comprehensive overview of applications and characterizations of titanium alloy surface coating in artificial knee joint by thermal spray coating technology.

[J.-C. Hsiung, H.-K. Kung, H.-S. Chen, Kuan-Yu Chang. **Applications of Thermal Spray Coating in Artificial Knee Joints.** Life Science Journal. 2012;9(1):457-463] (ISSN:1097-8135). <http://www.lifesciencesite.com>. 68

**Keywords** Thermal spray coating; Artificial knee joint; Titanium alloy

### 1. Introduction

With medical advances, life expectancy gradually extends. As people become older, the human bones and joints wear badly due to long-term use and deterioration. Then it leads to pain or malfunction of joints. When joint disease becomes severe, artificial joint replacement surgery can significantly relieve pain and improve joint function. Knee joints are the largest and most important joints, which are vulnerable to various injuries and diseases. Currently there are around 20,000 cases per year for the artificial knee joint replacement surgery in Taiwan, and this surgery is fairly common in orthopedic surgery<sup>[1-3]</sup>. Knee structure is mainly composed of the femur, tibia, patella and meniscus formed and fixed by the external muscles and ligaments. Typical components commonly used in artificial knee joint contain the femoral components, tibial components, patella and tibial bearing component as shown in Figure 1<sup>[4]</sup>. Existing artificial knee joint biomedical materials are metals, ceramics, polymers and composite materials. Because the metallic materials have excellent mechanical properties, easy processing and stability, they have been widely used in artificial joints<sup>[5-10]</sup>. The selection criteria for biomedical metallic material are: the minimum biological response in the body and to meet the basic functional requirements of the replacement and repair tissues. Owing to the mechanics and the common needs of the body environment, three types of metallic materials (stainless steel, cobalt alloys and titanium alloys) are mainly used for the artificial knee joint. Among them, titanium alloys are the preferred medical materials because of density as close to human bones, low

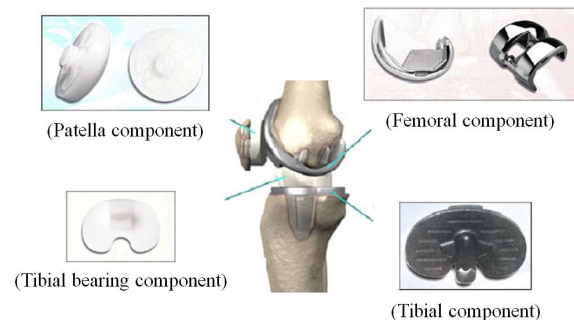
modulus, corrosion resistance and biocompatibility better than stainless steel and cobalt alloy<sup>[11,12]</sup>.

Thermal spray technology encompasses a group of coating processes that provide functional surfaces to protect or improve the performance of a substrate or component. Many types and forms of materials can be thermal sprayed—which is why thermal spray is used worldwide to provide protection from corrosion, wear, and heat; to restore and repair components; and for a variety of other applications<sup>[13,14]</sup>. Compared with other industrial applications, biomedical coating is a relatively new class of applications for thermal spray coating<sup>[13-16]</sup>. Thermal spray processes are grouped into three major categories: flame spray, electrical arc spray, and plasma arc spray. These energies sources are used to heat the coating material (in powder, wire, or rod form) to a molten and semi-molten state. The resultant heated particles are accelerated and propelled towards a prepared surface by either process gases or atomization jets.

Titanium alloys with excellent mechanical and biological properties have been proven to be effective in clinical medical application. In order to improve the biological activity, wear resistance and corrosion resistance of titanium alloy, the implementation of its surface modification becomes quite important<sup>[17,18]</sup>. The types of coating applied in the artificial knee joint are usually biological coatings. These biological coatings mainly include aluminum oxide ( $Al_2O_3$ ), zirconia ( $ZrO_2$ ) and Hydroxyapatite (HA). The purpose of this study was to make a comprehensive overview of applications and characterizations of titanium alloy surface coating in artificial knee joint by thermal spray



coating technology, in order to understand and master the titanium surface modification technology and related mechanisms.



**Figure 1** The components of an artificial knee joint.

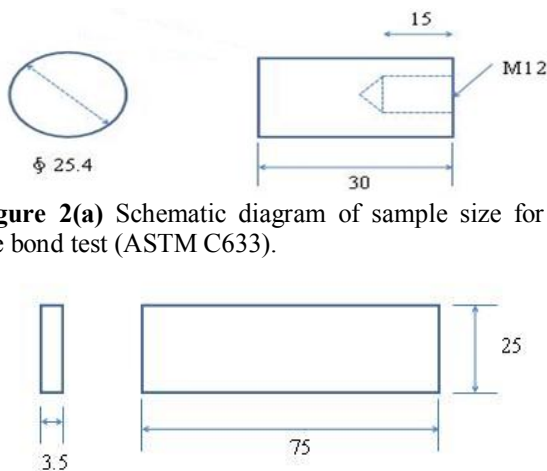
## 2. Experimental Procedures

### 2.1 Experimental Materials

The materials used in this study were bars and plates of titanium alloys (Ti-6Al-4V). The bars were mainly used for bond strength test, and the plates were used in many tests. They were used for the wear test, observing metallographic microstructure, hardness and other tests. The properties of titanium alloy are shown in Table 1, the sample size of the bar is  $\phi 25.4\text{mm} \times 30\text{mm}$  and the plate is  $75 \times 25 \times 3.5\text{mm}$ , as shown in Figure 2 (a) and 3 (b).

**Table 1** The material properties of titanium alloy tested.

Chemical composition	Al	V	Fe	C	N	H	O	Ti
	5.5-6.75	3.5-4.5	$\leq 0.20$	$\leq 0.08$	$\leq 0.05$	$\leq 0.015$	$\leq 0.020$	Remainder
Mechanical	Tensile Strength(MPa)		Yield Strength(MPa)		Elongation(%)		Bending test	Hardness(HRC)
Properties	$\geq 895$		$\geq 825$		$\geq 10$		$\geq 25^\circ$	$34 \pm 2$



**Figure 2(a)** Schematic diagram of sample size for the bond test (ASTM C633).

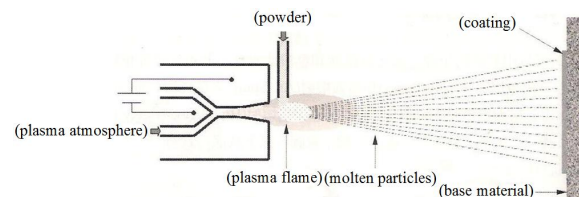
**Figure 2(b)** Schematic diagram of sample size for the wear test (ASTM G65).

### 2.2 Thermal Spray Coating Technology

The atmospheric plasma spray (APS) equipment made by Sulzer Metro Company (Spray Gun Type:

9MB) was used in this study. Plasma temperatures in the powder heating region range from 6000 to 15,000°C, significantly above the melting point of any known material. Three kinds of powder materials such as alumina ( $\text{Al}_2\text{O}_3$ ), zirconia ( $\text{ZrO}_2$ ) and hydroxyapatite (HA) are melted respectively, and then molten particles were guided through by air to form a coating on the substrate, as shown in Figure 3.  $\text{Al}_2\text{O}_3$  and  $\text{ZrO}_2$  ceramic materials are biologically inert, while the HA is a bioactive ceramic material. Hydroxyapatite (HA) is calcium phosphate ceramic  $[\text{Ca}_{10}(\text{PO}_4)_6(\text{OH})_2]$  that exhibits strong activity for joining to bone tissue.

The thermal spray process conditions of the three coating materials were shown in Table 2. Table 2 shows the important parameters affecting the quality of the coating, which includes inert gas composition, current, voltage, powder feeding rate, spraying distance and etc. HA powder was used in the inert gases of argon and helium, which is different from the  $\text{Al}_2\text{O}_3$  and  $\text{ZrO}_2$  used in the argon and hydrogen gas mixture. Before coating, the substrate surfaces were cleaned, degreased, and roughened in order to improve the bonding strength.



**Figure 3** Schematic diagram of thermal spray coating [13].

**Table 2** Thermal spray parameters for HA,  $\text{Al}_2\text{O}_3$ ,  $\text{ZrO}_2$  powders.

Hydroxyapatite (HA)									
Parameters	Argon (l/min)	Helium (l/min)	Current (A)	Voltage (V)	Powder rate (g/min)	Spray distance (mm)	Surface speed (75m/min)	Traverse speed (8mm)	Cooling
Setting	41	60	700	52	30	115	75	8	yes
$\text{Al}_2\text{O}_3$									
Parameters	Argon (l/min)	Hydrogen (l/min)	Current (A)	Voltage (V)	Powder rate (g/min)	Spray distance (mm)	Surface speed (75m/min)	Traverse speed (8mm)	Cooling
Setting	41	14	600	72	35	110	75	8	yes
$\text{ZrO}_2$									
Parameters	Argon (l/min)	Hydrogen (l/min)	Current (A)	Voltage (V)	Powder rate (g/min)	Spray distance (mm)	Surface speed (75m/min)	Traverse speed (8mm)	Cooling
Setting	41	9	600	68	28	120	75	8	yes

### 2.3 Characterization of Surface Coating

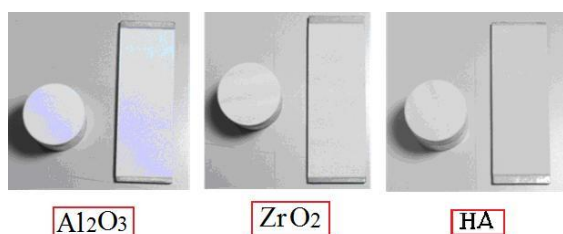
The surface coating quality of three kinds of coating materials ( $\text{Al}_2\text{O}_3$ ,  $\text{ZrO}_2$ , HA) on Ti-6Al-4V titanium alloy substrate by plasma thermal spraying was tested and characterized. These tests include coating appearance inspection, surface roughness measurement, coating thickness measurement, bond

strength test (ASTM C633), the porosity test, abrasion test (ASTM G65), hardness test and analysis of metallographic microstructure.

### 3. Results and Discussion

#### 3.1 Coating Appearance Inspection

The initial coating quality information can be obtained by visual inspection of appearance after thermal spray coating. The appearance inspection focuses on the existence of macroscopic defects such as coarse particles, coating spalling, cracks, shadows, or deformation. The results, as shown in Figure 4, showed that there are no coarse particles, coating spalling, cracks and other defects on the coating surface, and the coating layer is smooth, coating color is even without overheating oxidation.



**Figure 4** Coating appearance inspection of three kinds of coating materials.

#### 3.2 Surface Roughness Measurement

Surface morphology of the coating can be obtained by surface roughness measurement. The central average roughness (Ra) and the ten-point average roughness (Rz) are commonly used as index of surface roughness. The results indicated that ZrO<sub>2</sub> has the larger surface roughness (Ra, Rz) than Al<sub>2</sub>O<sub>3</sub> and HA.

**Table 3** Surface roughness measurements of ZrO<sub>2</sub>, Al<sub>2</sub>O<sub>3</sub> and HA.

Specimen	Ra	Rz
Al <sub>2</sub> O <sub>3</sub>	5.556μm	43.732μm
HA	7.235μm	54.906μm
ZrO <sub>2</sub>	9.973μm	71.223μm

#### 3.3 Coating Thickness Measurement

The results of the coating thickness of three coating materials under the thermal spray process parameters in Table 2 were acquired by the metallographic observation of the specimen and shown in Table 4 and Figure 5 (a) ~ (c).

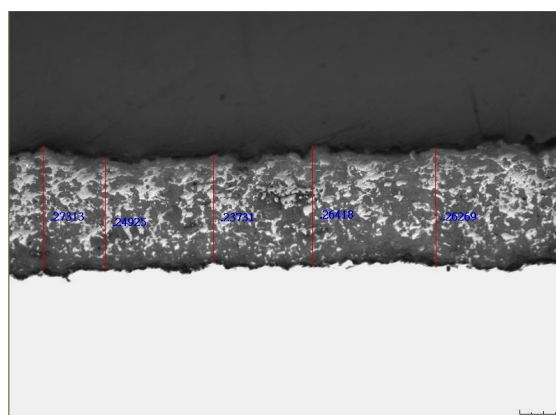
#### 3.4 Bond Strength Test (ASTM C633)

The main purpose of the test is to understand the adhesion between coating and substrate. The tensile test is commonly used to evaluate the bond strength per ASTM C633 standard method<sup>[19]</sup>. The schematic

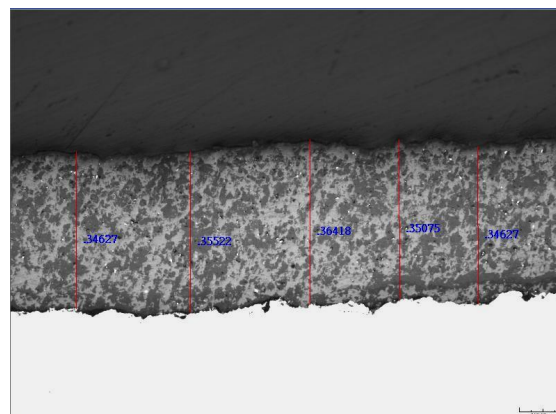
of the bond strength test is shown in Figure 6. Bond strength test results showed that HA coating has the lower bond strength (33.2MPa) than Al<sub>2</sub>O<sub>3</sub> (47.1MPa) and ZrO<sub>2</sub> (55.9MPa) coating, as shown in Table 5.

**Table 4** Coating thickness measurements of three different coating materials under the thermal spray process parameters in Table 2.

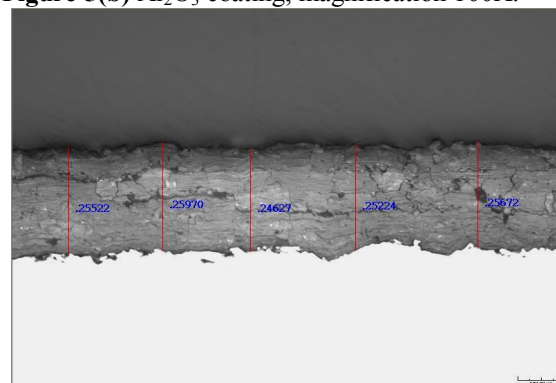
Specimen	Thickness (um)
ZrO <sub>2</sub>	237~273
Al <sub>2</sub> O <sub>3</sub>	346~364
HA	246~260



**Figure 5(a)** ZrO<sub>2</sub> coating, magnification 100X.



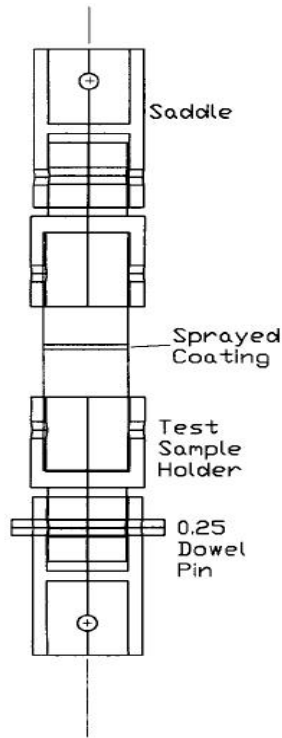
**Figure 5(b)** Al<sub>2</sub>O<sub>3</sub> coating, magnification 100X.



**Figure 5(c)** HA coating, magnification 100X.

**Table 5** Bond strength test results of three different coatings.

Coating type	Bond strength
HA	33.2MPa
Al <sub>2</sub> O <sub>3</sub>	47.1MPa
ZrO <sub>2</sub>	55.9MPa



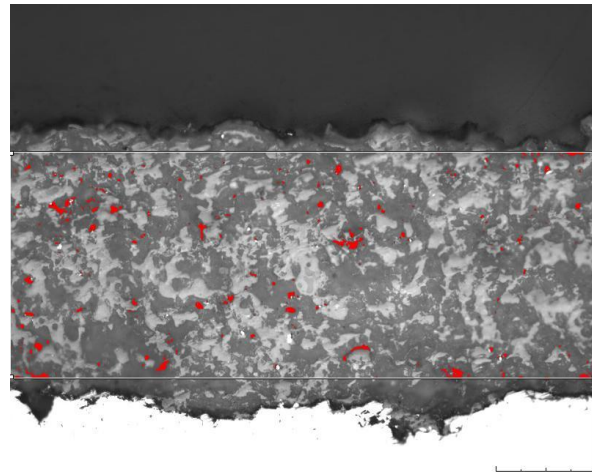
**Figure 6** Schematic diagram of bond strength test

**3.5 Porosity Test**

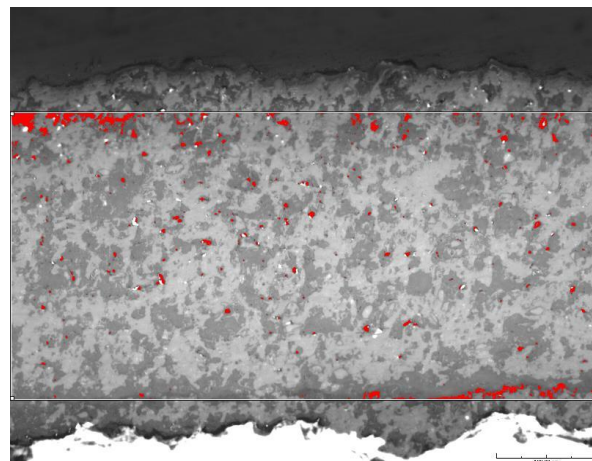
The specimens (HA , Al<sub>2</sub>O<sub>3</sub> , ZrO<sub>2</sub>w) were prepared by mounting, grinding and polishing processes and observed randomly the selected three individual locations using an optical microscope, then analyzed by image analysis software. The porosity results were shown in Table 6 and Figure 7 (a) ~ (c). The results showed that porosity of the coating of Zirconia(ZrO<sub>2</sub>) and Alumina(Al<sub>2</sub>O<sub>3</sub>) was less than Hydroxyapatite(HA) coating.

**Table 6** Porosity test results of ZrO<sub>2</sub> , Al<sub>2</sub>O<sub>3</sub> and HA coatings.

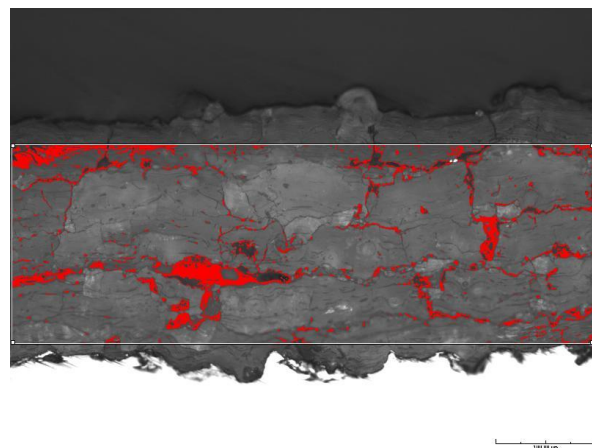
Coating type	Porosity (%)	Mean (%)
ZrO <sub>2</sub>	1.17 1.10 1.31	1.19
Al <sub>2</sub> O <sub>3</sub>	1.55 1.58 2.20	1.54
HA	5.67 5.28 2.87	5.49



**Figure 7(a)** The porosity test result of Zirconia (ZrO<sub>2</sub>) coating, the red zones are the holes.



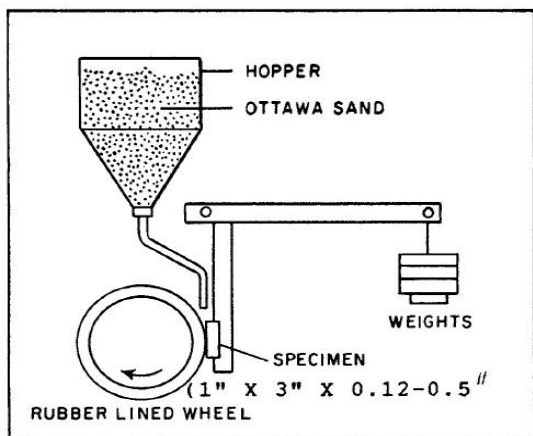
**Figure 7(b)** The porosity test result of Alumina (Al<sub>2</sub>O<sub>3</sub>) coating, the red zones are the holes.



**Figure 7(c)** The porosity test result of Hydroxyapatite (HA) coating, the red zones are the holes.

### 3.6 Abrasion Test (ASTM G65)

The abrasion test is based on the ASTM G65 specification [20]. This test is a way of abrasive particle wear with rubber wheels and round quartz. The schematic of the abrasion test was shown in Figure 8. The abrasion test (ASTM G65) results showed that HA has lower volume wear rate than  $\text{Al}_2\text{O}_3$  and  $\text{ZrO}_2$ , as shown in Table 7.



**Figure 8** Schematic diagram of abrasive wear test [13]

**Table 7** Abrasion test results of three different coating materials.

Specimen-	HA (Density : 3.08 g/cm <sup>3</sup> )	$\text{Al}_2\text{O}_3$ (Density : 3.3 g/cm <sup>3</sup> )	$\text{ZrO}_2$ (Density : 4.48 g/cm <sup>3</sup> )
Weight before wear (g)	31.43	31.29	31.49
Weight after wear (g)	31.34	31.17	31.15
Mass loss (g)	0.09	0.12	0.34
Volume Loss (mm <sup>3</sup> )	29.22	36.36	75.89

$$\text{* Volume Loss (mm}^3\text{)} = \frac{\text{mass loss (g)}}{\text{density (g/cm}^3\text{)}} \times 1000$$

### 3.7 Hardness Test

The micro-hardness test method (Vickers Hardness) was used to measure the hardness of Ti-6Al-4V substrate and the coating layers (at different locations). The results indicated that the micro-hardness values of  $\text{ZrO}_2$ ,  $\text{Al}_2\text{O}_3$  and HA are much higher than that of Ti-6Al-4V substrate as shown in Table 8. In addition, the inside hardness of coating is higher than the middle and outer hardness.

**Table 8** Micro-hardness test results of three coating materials.

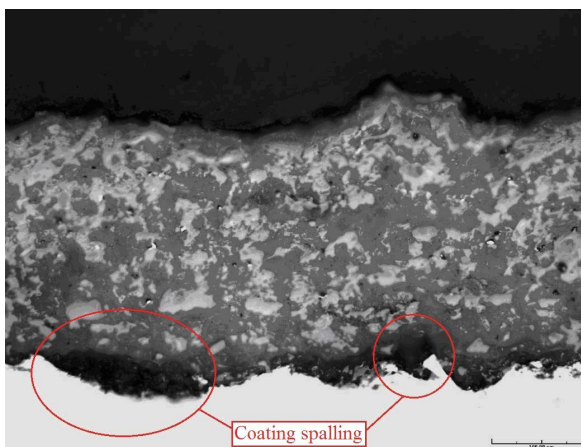
Specimen	Outside	Middle	Inside	Ti substrate
$\text{ZrO}_2$	381	391	412	337
$\text{Al}_2\text{O}_3$	407	409	411	332
HA	388	407	396	325

### 3.8 Metallurgical Microstructure Analysis

The thermal spray coating may result in many defects within the coating because the characteristics of the technology itself or improper process control. Through metallographic microstructure analysis, the quality of the thermal spray coating can be verified. The defects of three different coatings were shown in Table 9 and Figure 9 (a) ~ (g). Table 9 showed that three kinds of coatings are free of cracks, interface contamination, not molten particles, clusters of oxides and strip oxides, but with the phenomenon of layer spalling and interface separation. These results indicated that the adhesive strength between the coating layers and the bond strength between the coating and the substrate are weak. There were not any huge holes found in  $\text{ZrO}_2$  and  $\text{Al}_2\text{O}_3$  coating, however huge holes were found in HA coating (Figure 10 (g)). The existence of a small amount of small holes in the coating is usually normal. However, large holes or high porosity will have an adverse impact on mechanical properties of the coating, such as lower bond strength. The existence of huge holes and high porosity in HA coating can explain why the bond strength of HA coating is lower, as shown in Table 5.

**Table 9** Coating defects of three different coating materials.

Specimen	$\text{ZrO}_2$	$\text{Al}_2\text{O}_3$	HA
Crack	N	N	N
Coating spalling	Y	Y	Y
Interface contamination	N	N	N
Interface separation	Y	Y	Y
Not molten particles	N	N	N
Huge holes	N	N	Y
Clusters of oxides	N	N	N
Strip oxides	N	N	N



**Figure 9(a)**  $\text{ZrO}_2$  coating, magnification 200X.

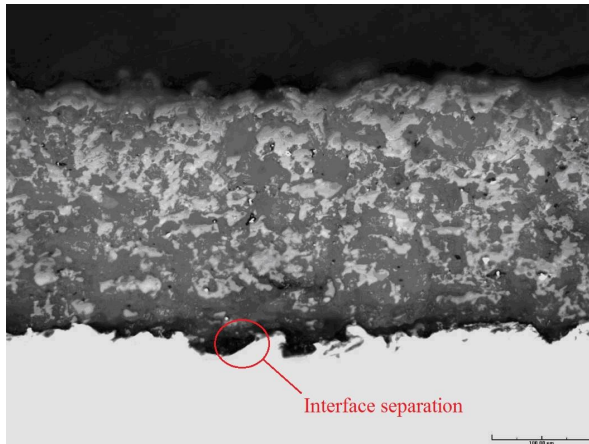


Figure 9(b) ZrO<sub>2</sub> coating, magnification 200X.

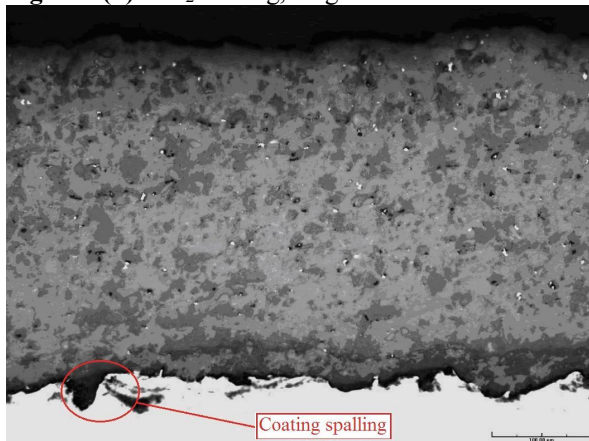


Figure 9(c) Al<sub>2</sub>O<sub>3</sub> oxide coating, magnification 200X.

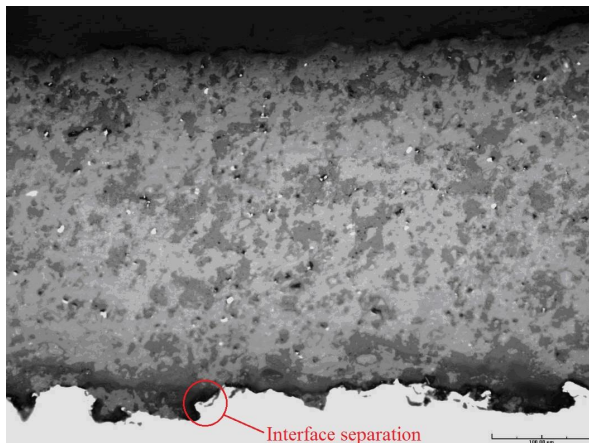


Figure 9(d) Al<sub>2</sub>O<sub>3</sub> oxide coating, magnification 200X.

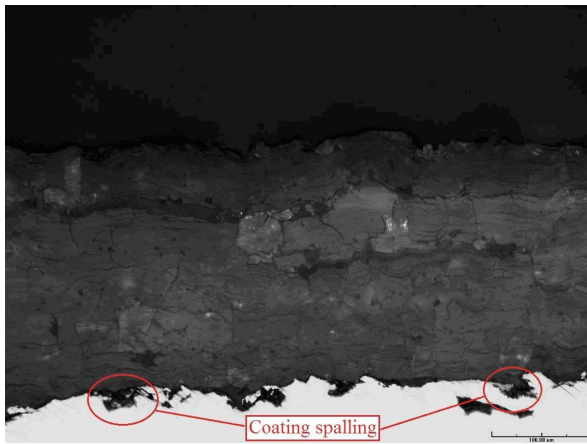


Figure 9(e) HA coating, magnification 200X.

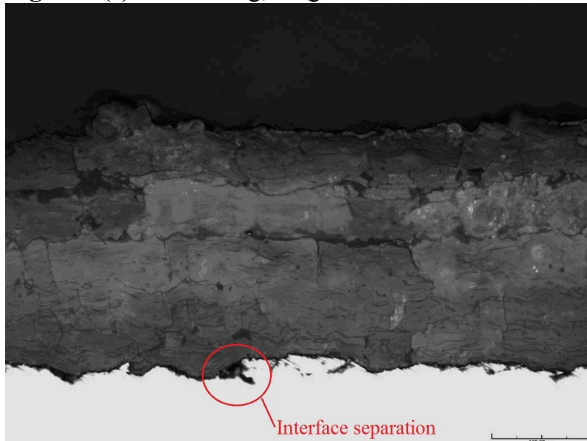


Figure 9(f) Hydroxyapatite coating, magnification 200X.

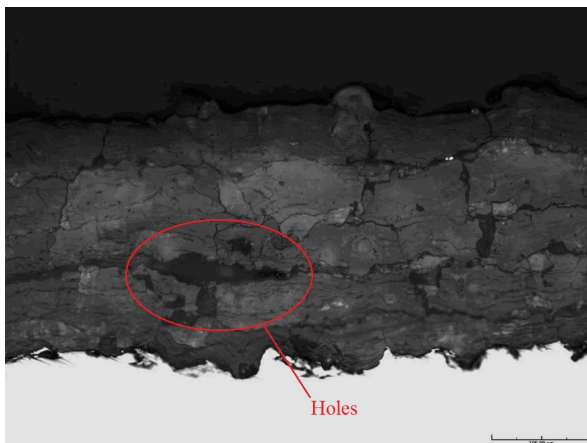


Figure 9(g) Hydroxyapatite coating, magnification 200X.

#### 4. Conclusions

In this study, we have made a concise and comprehensive overview of applications and characterizations of titanium alloy surface coating in artificial knee joint by thermal spray coating technology although the experimental results were

preliminary. Due to the different material properties, the process parameters of atmospheric plasma spraying for the three commonly used biological coating materials ( $\text{Al}_2\text{O}_3$ ,  $\text{ZrO}_2$ , HA) were quite different, experimental results displayed the very different characteristics of surface roughness, coating thickness, bond strength, porosity, abrasion, hardness and metallographic microstructure of these three coating materials. In addition, the coating spalling and interface separation were found in  $\text{Al}_2\text{O}_3$ ,  $\text{ZrO}_2$  and HA coatings from the metallographic microstructure analysis, and there is a problem of higher level of porosity and huge holes in the HA coating. Further studies need to be done to verify the effects of APS process parameters (such as spraying program voltage, current, spraying distance, gas flow and gas composition parameters, feed particle size, feeding rate) and pre-treatment status (cleaning) of the substrate surface on the coating quality.

#### Acknowledgements

The authors would like to thank the financial support of National Science Council, Taiwan (Project: Engineering Analysis and Manufacturing of Human Knee Joints and its Prosthesis, NSC 99-2632-E-230-001-MY3).

\*Corresponding Author:

J.-C. Hsiung, PhD

E-mail : [jchsiung@csu.edu.tw](mailto:jchsiung@csu.edu.tw)

#### References

- Chen Weijih, Hu Jihjian, "What are artificial joint - materials and types of artificial joints", Chang Gung Memorial Hospital, Volume 30, No. 11, November 2009.
- Huang Syuandi, "Introduction of development of new materials and technologies for artificial joints", Kaohsiung Medical University Chung-Ho Memorial Hospital, Volume 23, No. 8, January 2004.
- Syu Yeliang, Lyu Dongwu, "New design of the total knee joint", National Science Council Report, 2001.
- Ministry of Economic Affairs, industry and technical knowledge Service plan, "Market analysis of metal orthopedic devices", 2005.
- Jhu Jinguo, Nanjing University of Chinese Medicine "Artificial joint materials research and clinical application of bone", 2008.
- Gai Syuejhou, Rao Pinggen, Jhao Guangyan, Wu Jiancing, "Research on artificial joint materials", South China Institute of Materials Science and Engineering, Volume 20, No. 1, January 2006.
- Jeng-Nan Lee and Kuan-Yu Chang, An Integrated Investigation of CAD/CAM for the Development of Custom-made Femoral Stem, Life Science Journal, Vol 7, No 1, 2009.
- Wafaa I. Shereif and Amira A. Hassanin, Comparison between Uses of Therapeutic Exercise and Heat Application on Relieve Pain, Stiffness and Improvement of Physical Function for Patient with Knee Osteoarthritis, Life Science Journal, 2011;8(3).
- C. I. Nwoye, G. C. Obasi, U. C Nwoye, K. Okeke, C. C. Nwakwuo and O. O Onyemaobi, Model for Calculating the Concentration of Upgraded Iron Designated for Production of Stainless Steel Based Devices Used in Orthopaedics, Life Science Journal, Volume 7, Issue 4, 2010.
- Yen Ke Tien and Chang Kuan Yu, Tai chi exercise affects the isokinetic torque but not changes hamstrings: quadriceps ratios, Life Science Journal, Vol 6, No 4, 2009.
- Liou Syuanyong, Biomedical Titanium Alloys and Surface Modification, Chemical Industry Press, 2009.
- Marc Long, H.J. Rack, "Titanium alloys in total joint replacement- a materials science perspective", Biomaterials, 9(1998) 1621-1639.
- Siao Weidian, Thermal Spray Technology, CHWA Technology Company, 2006.
- Wang Haiyun, Materials and applications of thermal spray, National Defense Industry Press, 2008.
- Robert B. Heimann, "Thermal spraying of biomaterials", Surface and Coatings Technology, 201 (2006) 2012-2019.
- Hong Liang, Bing Shi, Aaron Fairchild, Timothy Cale "Applications of plasma coating in artificial joints: an overview", Vacuum 73 (2004) 317-326.
- Fujisawa, I. Noda, Y. Nishio, H. Okimatsu "The development of new titanium arc-sprayed artificial joints", July 1995, Pages 151-157.
- R. Gadow, A. Killinger, N. Stiegler "Hydroxyapatite coatings for biomedical applications deposited by different thermal spray techniques", surface and coating Technology, 2010, 1157-1164.
- ASTM C633-1(Reapproved 2008), "Standard Test Method for Adhesion or Cohesion Strength of Thermal Spray Coatings".
- ASTM G65-04, "Standard Test Method for Measuring Abrasion Using the Dry Sand/Rubber Wheel Apparatus".

1/2/2012